

FACTORY JACKETED AND INSULATED STORAGE TANKS

Large volume tanks are designed for storing potable water. Fitting locations of these custom-line tanks match the needs of normal installations plus those for the State Cer-Temp® 80 and Shure-Temp™ systems.

FEATURES

STANDARD SIZES

- From 140 to 2,500 gallons - State stocks vertical factory jacketed and insulated tanks from 140 gallons up to 2,500 gallons for fast delivery and retrofit applications. All stock tanks are glasslined with standard tank openings as shown on following pages. For custom or larger capacities, see our custom line tanks or consult your factory representatives.

ASME CODE CONSTRUCTION

- All tanks are constructed to the requirements of the ASME. Please see table footnotes for working pressure.

INSULATION

- Entire tank is insulated to meet ASHRAE 90.1. To meet ASHRAE 90.1 (current edition) depth of insulation cavity requires use of remote bulbtype tank temperature control and thermometer. Storage tanks meet R12.5 minimum thermal insulation requirements of the U.S. Department of Energy and current edition of ASHRAE/IESNA 90.1

CABINET

- Heavy gauge steel with high quality paint.

LININGS

- Glasslined (Standard) - These are normally stocked tanks for water storage up to 180°F, with glass lining to prevent corrosion and addition of rust to water. The glass lining was developed over many years of ceramic research for a wide variety of conditions.

CATHODIC PROTECTION

- Tanks are furnished with anodes designed for maximum protection.

ACCESSORIES

- Tanks will be supplied with the fittings located as indicated on the drawings unless specified otherwise.

Attention: Significant changes have been made to models now manufactured in Lebanon, TN. Please note that this Spec Sheet refers to models manufactured in MeBee, SC and Lebanon, TN.

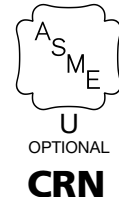

SOLID. STATE.

STORAGE TANK SELECTION PVG-140 THRU PVG-400 FIGURE 1.

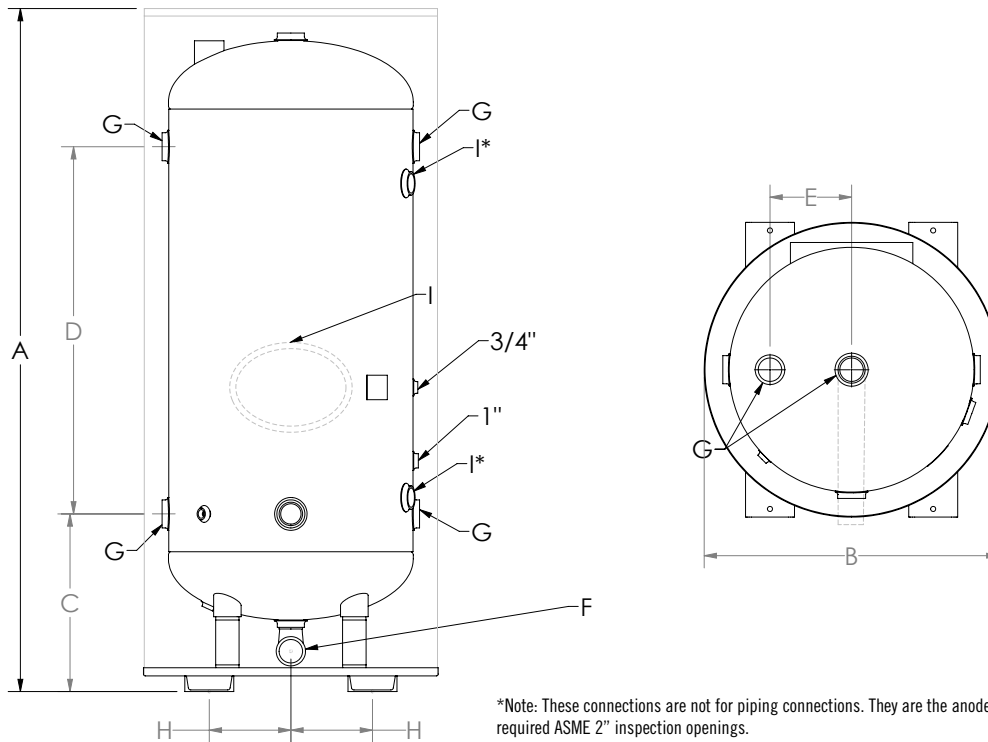

*Note: These connections are not for piping connections. They are the anode locations and also serve as the required ASME 2" inspection openings.

- NOTE:**
- Other tanks to 72" diameter and 3500 gallon are available on special order.
 - All openings Female Pipe Thread except as noted.
 - "F" opening Male Pipe Thread.

Model Number	A	B	C	D	E	F	G	H	"I" ASME Inspection Openings
PVG-0140-00VTA125	87	30	21 1/2	51	8	1 1/2	2 1/2	6 3/8	2"
PVG-0200-00VTA125	83	36	22	45	10	1 1/2	2 1/2	7 3/4	2"
PVG-0250-00VTA125	96	36	22	58	10	1 1/2	2 1/2	7 3/4	2"
PVG-0350-00VTA125	97	42	24 1/2	54	14	1 1/2	2 1/2	9 1/2	2"
PVG-0400-00VTA125	105	42	24 1/2	61	14	1 1/2	2 1/2	9 1/2	2"

Working pressure for all models less than 500 gallons is 160 PSI

DIMENSION AND SHIPPING WEIGHTS

VERTICAL ROUND JACKETED ASME

Model Number	A	B	C	D	Gallons
PVG-500-00VSA125	91	46	20.75	2"	500
PVG-500-00VTA125	77	52	22.875	2"	500
PVG-600-00VTA125	88	52	22.875	2"	600
PVG-700-00VTA125	97	52	22.875	2"	700
PVG-750-00VTA125	100	52	22.875	2"	750
PVG-1000-00VTA125	124	52	22.875	2"	1000

Working Pressure 125 PSI standard, 150 PSI optional

VERTICAL SQUARE JACKETED ASME

Model Number	A	B	C	D	Gallons
PVG-1250-00VTA125	133	60	24.375	3"	1,250
PVG-1500-00VTA125	129	66	25.875	3"	1,500
PVG-1750-00VTA125	153	66	25.875	3"	1,750
PVG-2000-00VTA125	126	78	28.375	3"	2,000
PVG-2500-00VTA125	146.5	78	28.375	3"	2,500

Working Pressure 125 PSI standard, 150 PSI optional

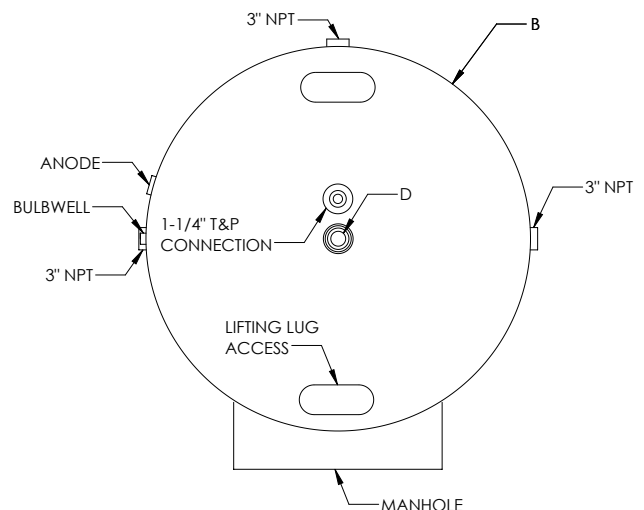
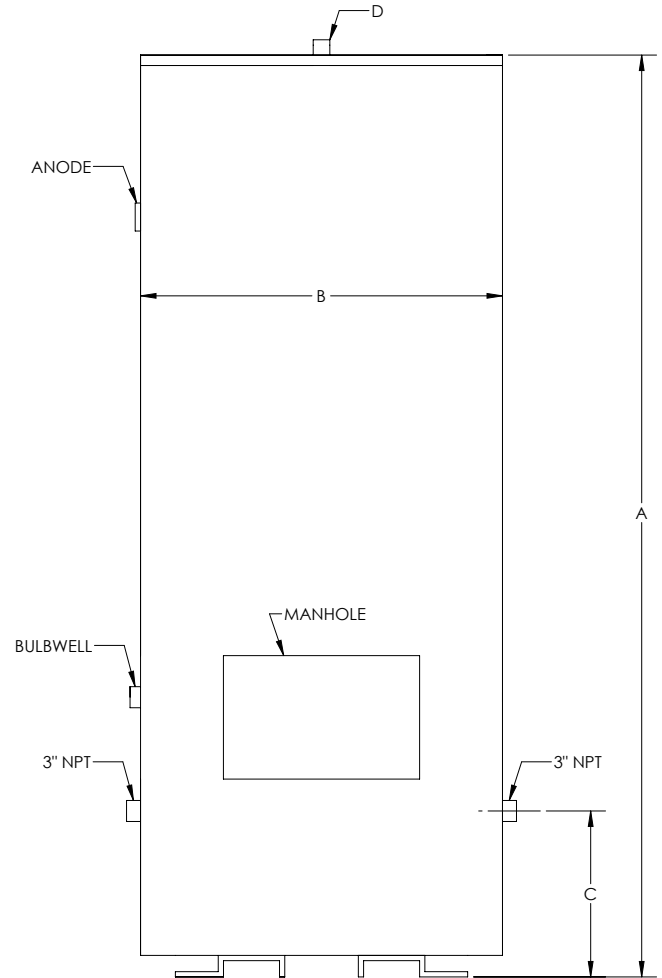

CAUTION

All openings are shipped open and unused. Openings must be plugged or capped at time of installation except as noted.

DIMENSIONS AND SPECIFICATIONS FOR HORIZONTAL TANKS

HORIZONTAL ROUND JACKETED ASME TANKS

Model Number	A	B	Diameter	Gallons
PVG-0250-00HTA125	41	87	34	250
PVG-0300-00HTA125	47	76	40	300
PVG-0400-00HTA125	53	76	46	400
PVG-0500-00HTA125	53	87	46	500
PVG-0500-00HTA125	59	77	52	500
PVG-0600-00HTA125	59	88	52	600
PVG-0700-00HTA125	59	97	52	700
PVG-0750-00HTA125	59	100	52	750
PVG-1000-00HTA125	59	124	52	1000

Working Pressure 125 PSI standard, 150 PSI optional

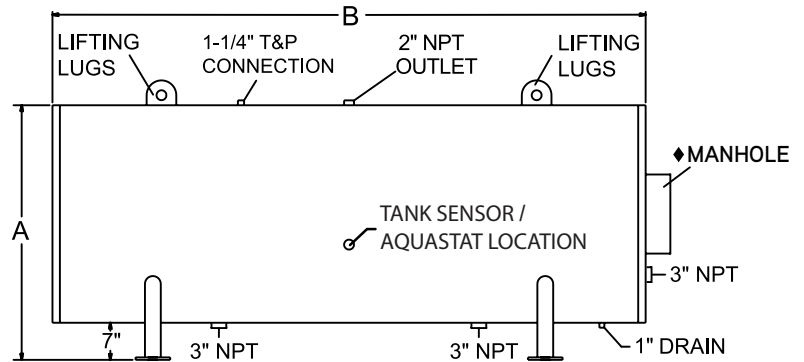

HORIZONTAL SQUARE JACKETED ASME TANKS

Model Number	A	B	Depth	Gallons
PVG-1250-00HTA125	68.5	134	60.25	1,250
PVG-1500-00HTA125	74.5	127	66.25	1,500
PVG-2000-00HTA125	86.5	127	78.25	2,000
PVG-2500-00HTA125	86.5	144	78.25	2,500

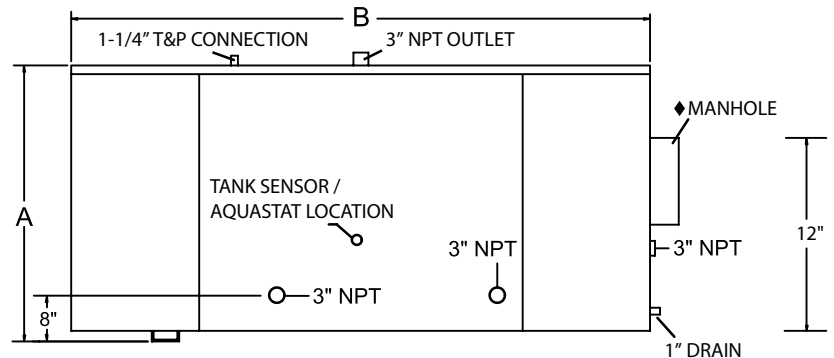

LIMITED WARRANTY OUTLINES

GLASSLINED: If the tank should leak anytime during the first five years, under the terms of the warranty, State will repair or replace the tank; installation, labor and handling extra.

NOTE: THIS OUTLINE IS NOT A WARRANTY. For complete information, consult the written warranty or State. Warranty does not apply to product installed outside of the United States of America or its territorial possessions and Canada.

SAMPLE SPECIFICATION FOR CUSTOM-LINE STORAGE TANKS

When jacketed or insulated these models meet R12.5 minimum thermal insulation requirements of the U.S. Department of Energy and current edition of ASHRAE/IESNA 90.1. ASME storage tank to be State Custom-Line model _____. Capacity to be _____ gallons with a diameter of _____ inches. Tank(s) shall be constructed and stamped according to ASME specification for _____ psi working pressure. Manhole (12 X 16), handhole (4x6) or inspection openings (2-2") shall be installed in accordance with ASME code requirements and manufacturer(s) standard practice. Tank to be constructed of (carbon steel) _____. Lining shall be (glass) _____. Tank(s) lined with (glass) _____ lining shall be equipped with the number and size of magnesium anode rod(s) sufficient to provide adequate protection for the tank lining. Tank shall be (vertical, horizontal) _____ design and provided with _____ ring base, (or _____ Saddles.)