

REPAIR MOTOR KIT

Model: SWG-4HD, SWGII-4HD, SWG-5,
SWGII-5, SWG-6, SWGII-6

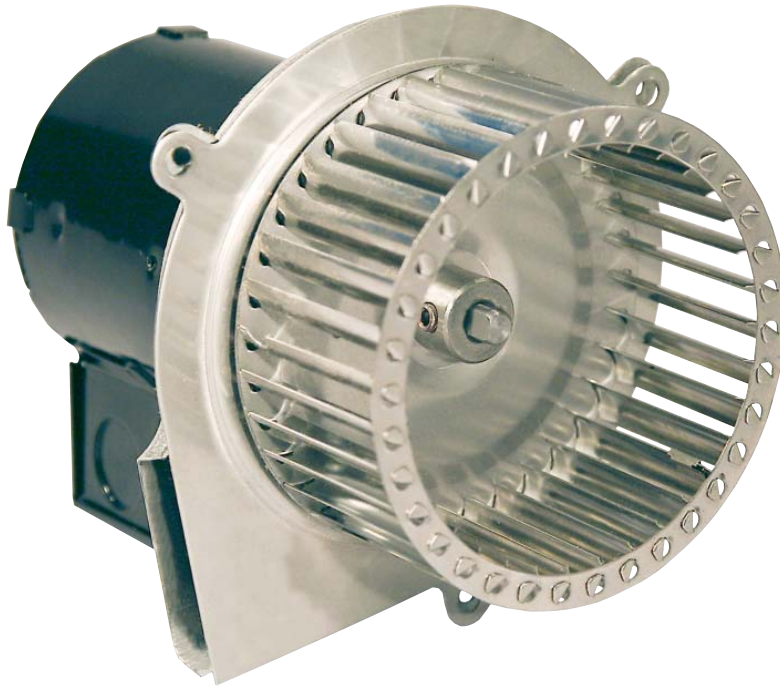

This kit includes a replacement assembly for the SWG and SWGII series sidewall power venter models listed above.

NOTE: Before working on power venter, shut off electrical power to control box.

ITEMS INCLUDED:

- 1- Replacement Motor and Blower Wheel on Mounting Bracket with Mounting Fasteners
- 1- $\frac{1}{8}$ " Hex wrench
- 1- Tube of high temperature silicone sealant
- 1- Instruction Sheet

READ THESE INSTRUCTIONS CAREFULLY AND COMPLETELY BEFORE PROCEEDING WITH THE INSTALLATION.

This device **MUST** be installed by a qualified agency in accordance with the manufacturer's installation instructions. The definition of a qualified agency is: any individual, firm, corporation or company which either in person or through a representative is engaged in, and is responsible for, the installation and operation of HVAC appliances, who is experienced in such work, familiar with all the precautions required, and has complied with all the requirements of the authority having jurisdiction.

Please retain these instructions after installation.

Installed By: _____ Phone: _____ Installation Date: _____



FIELD CONTROLS

www.fieldcontrols.com

IDENTIFY WHICH MODEL POWER VENTER YOU HAVE

CAUTION: Avoid applying excess pressure on the blower wheel when handling. This will cause an imbalance of the blower wheel which will result in excessive vibration and premature motor failure.

REMOVAL

1. Remove motor cover. (See Figure 1)
2. Remove the electrical box cover and disconnect the conduit and wires. (See Figure 2) It is not necessary to disconnect the wires from the Control Kit.
3. Remove the nuts securing the motor assembly, and pull the motor assembly straight off of the unit. (See Figure 3)
4. Clean off any build-up inside the blower wheel housing.

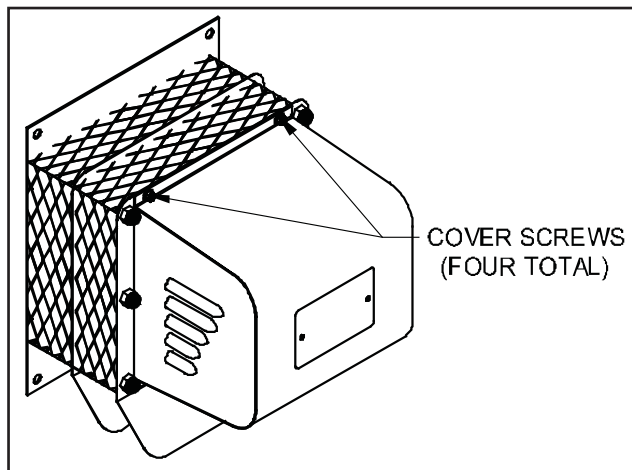

Figure 1

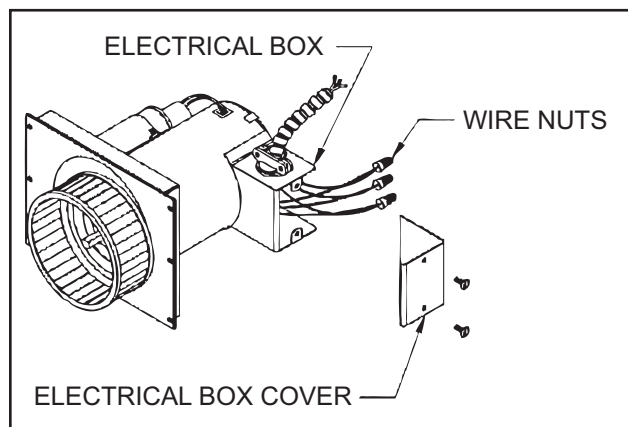

Figure 2

INSTALLATION

1. Align the holes in the circular cover plate with the holes in the motor mount bracket on the motor assembly. (See Figure 3)
2. Slide the motor assembly onto the protruding threaded studs on the power vent body with the exhaust chute pointing downward, and replace the nuts securely to the threaded studs. (See Figure 3)
3. Use the top knockout on the electrical box and reattach the flexible conduit and wires to the motor using the conduit connector and wire nuts. Secure the cover on the electrical box.
4. Seal around the edge of the motor mount bracket with the provided high temperature silicone sealant. Install the motor cover with the side louvers pointing downward. (See Figure 1)

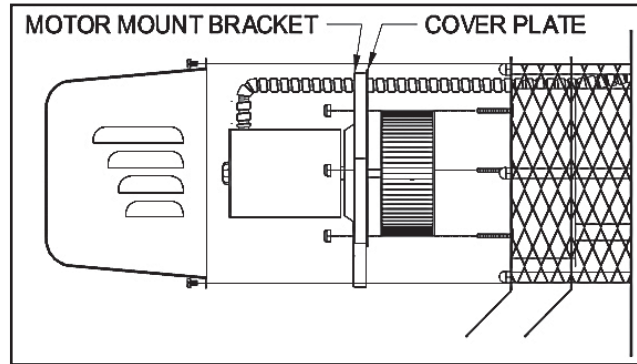

Figure 3

WARRANTY

For warranty about this or any Field Controls product, visit:
www.fieldcontrols.com/warranty



FIELD CONTROLS

Phone: 252.522.3031 • Fax: 252.522.0214
www.fieldcontrols.com