

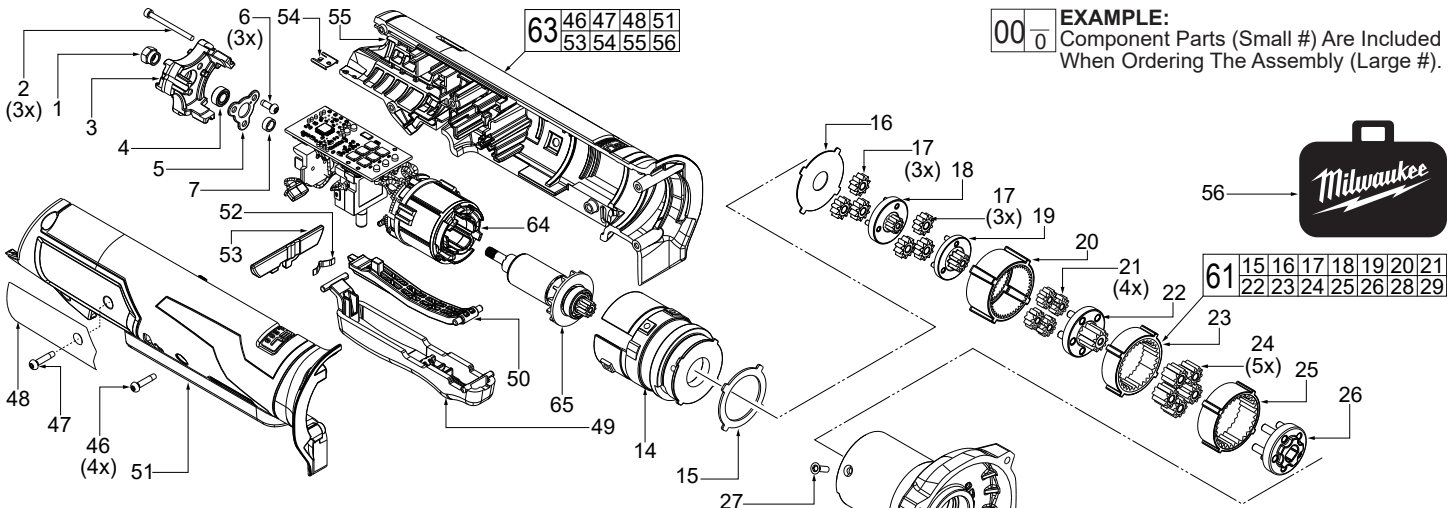

SERVICE PARTS LIST

BULLETIN NO.
54-47-0310

SPECIFY CATALOG NO. AND SERIAL NO. WHEN ORDERING PARTS		REVISED BULLETIN	DATE
M12™ FUEL™ PEX Expander			Mar. 2021
CATALOG NO. 2532-20	STARTING SERIAL NO. K97A	WIRING INSTRUCTION SEE PAGE 3	



EXAMPLE:
Component Parts (Small #) Are Included When Ordering The Assembly (Large #).



FIG.	PART NO.	DESCRIPTION OF PART	NO. REQ.
1	05-55-0047	Flange Nut	(1)
2	05-84-0200	M2.5 x 31mm Cap Hd. Hex Skt. Recess Sc.	(3)
3	44-66-1008	Motor Plate	(1)
4	02-04-0303	Ball Bearing	(1)
5	44-86-1405	Bearing Retaining Plate	(1)
6	06-82-2310	M3 x 8mm Pan Hd. Taptite T-10 Screw	(3)
7		Bushing	(1)
14	28-50-2523	Motor Housing	(1)
15		Sealing Washer	(1)
16		External Tooth Flat Washer	(1)
17		1st Layer and 2nd Layer Planet Gear	(6)
18		2nd Layer Sun Gear	(1)
19		3rd Layer Sun Gear	(1)
20		1st Layer and 2nd Layer Ring Gear	(1)
21		3rd Layer Planet Gear	(4)
22		4th Layer Sun Gear	(1)
23		3rd Layer Ring Gear	(1)
24		4th Layer Planet Gear	(5)
25		4th Layer Ring Gear	(1)
26		4th Layer Carrier	(1)
27	05-81-0105	M3 x 10mm Flat Hd. T-10 Machine Screw	(3)
28		Gear Case Support	(1)
29		Ball Bearing	(2)
32	43-74-0730	Belt Hook	(1)
33		Gear Case Cover	(1)
34	06-82-5320	8-32 x 5/8 Pan Hd. Taptite T-20 Screw	(4)
35	44-66-2180	Roller Pin	(1)
36	44-96-0230	Roller	(1)
37	32-75-1595	Spindle	(1)
38	45-88-1485	Flat Washer	(1)
39	40-50-2532	Return Spring	(1)
40	42-76-0064	Driver Collar	(1)
41	44-60-0413	Driver Collar Pin	(1)
42	40-50-1575	Sleeve Spring	(1)
43	42-76-0950	Rotation Collar	(1)
44	34-40-1050	O-Ring	(1)
45	45-22-1025	Sleeve	(1)
46	06-82-6351	M3 x 16mm Pan Hd. ST T-10 Screw	(4)
47	06-82-4003	M4 x 16mm Pan Hd. ST T-20 Screw	(1)
48	12-20-2020	Service Nameplate	(1)
49	31-92-0073	Trigger	(1)
50	31-52-2532	Trigger Lever	(1)
51		Right Housing Halve-Cover	(1)
52	40-50-0027	Spring Plate	(1)
53	42-42-0072	Lock-Off Shuttle	(1)
54	42-70-0058	Housing Connector	(1)
55		Left Housing Halve-Support	(1)
56	42-55-2532	Blow Molded Carrying Case	(1)
60	14-30-2532	Gear Case Cover Service Assembly	(1)
61	14-30-6240	Gear Case Housing/Gears Service Assy.	(1)
62	14-46-2090	Cam Service Assembly	(1)
63	14-34-2532	Housing Halve Service Kit	(1)
64	14-20-0094	Electronic Service Assembly	(1)
65	14-50-0120	Rotor Service Assembly	(1)
66	14-30-6240	Gear Case Support Service Assembly	(1)
67	49-16-2414	1/2" Head Assembly (Accessory, Optional)	(1)
	49-16-2416	3/4" Head Assembly (Accessory, Optional)	(1)
	49-16-2418	1" Head Assembly (Accessory, Optional)	(1)

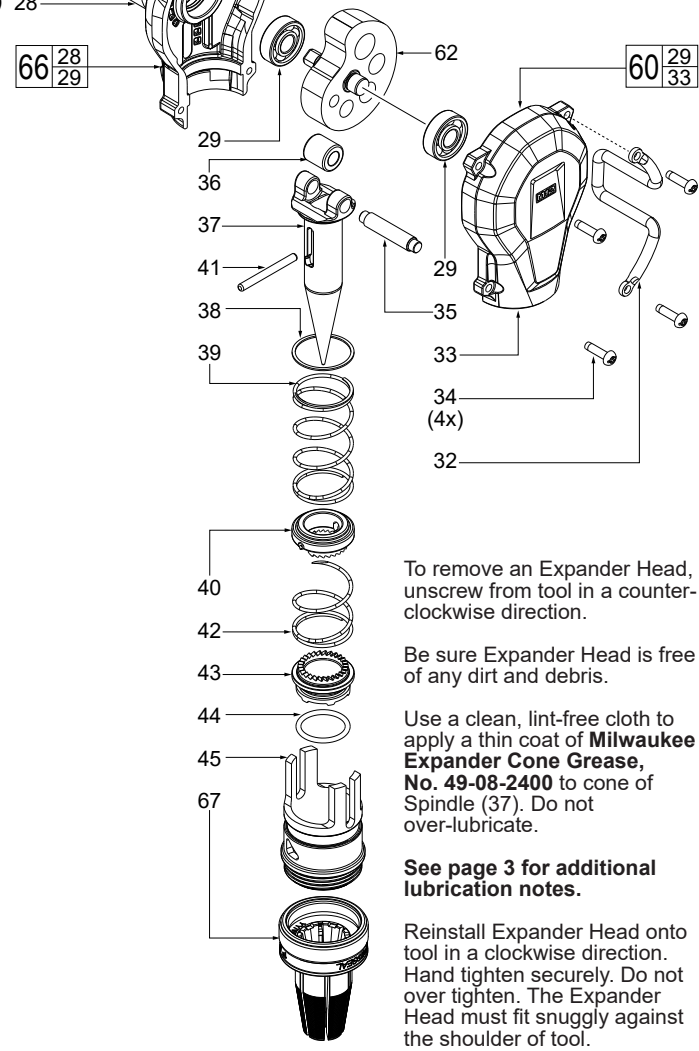

To remove an Expander Head, unscrew from tool in a counter-clockwise direction.

Be sure Expander Head is free of any dirt and debris.

Use a clean, lint-free cloth to apply a thin coat of **Milwaukee Expander Cone Grease, No. 49-08-2400** to cone of Spindle (37). Do not over-lubricate.

See page 3 for additional lubrication notes.

Reinstall Expander Head onto tool in a clockwise direction. Hand tighten securely. Do not over tighten. The Expander Head must fit snugly against the shoulder of tool.

LUBRICATION NOTES:

- **Type 'J' Grease, No. 49-08-4220** (1 lb. can)

NOTE: When servicing, remove 90-95% of the existing grease prior to installing Type 'J'. Original grease may be similar in color but not compatible with 'J'. Prior to reinstalling, clean gear assemblies with a clean, dry cloth. Lightly coat all individual parts highlighted here with grease. Apply a greater amount of grease to all internal and external gear teeth.

- **Type 'L' Grease, No. 49-08-4175** (1 lb. can)

NOTE: When servicing, remove 90-95% of the existing grease prior to installing Type 'L'. Original grease may be similar in color but not compatible with 'L'.

- **Milwaukee Expander Cone Grease, No. 49-08-2400**

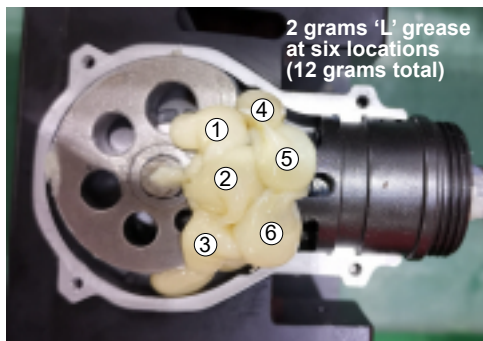
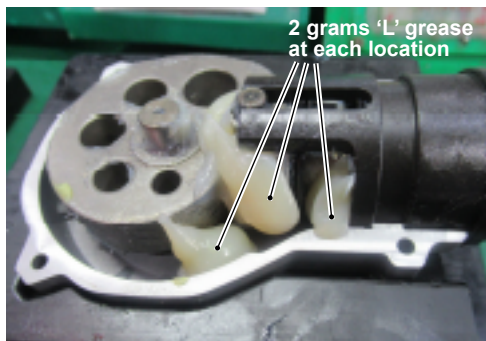
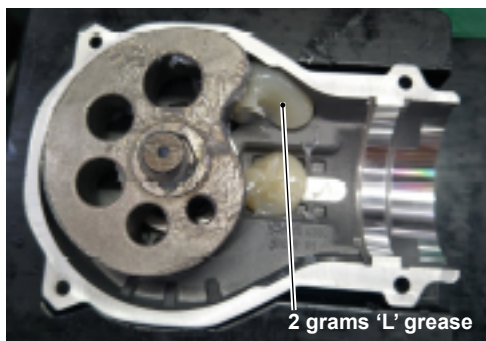
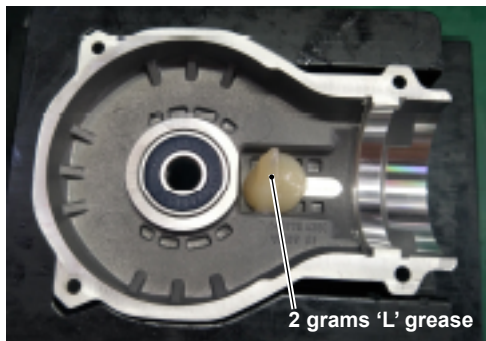
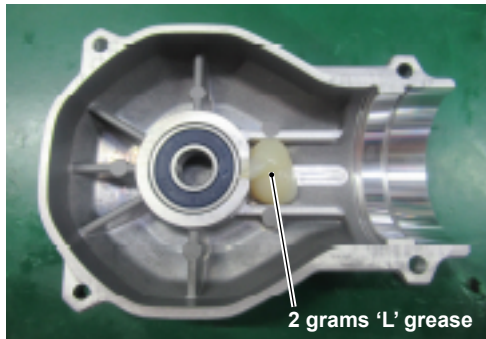
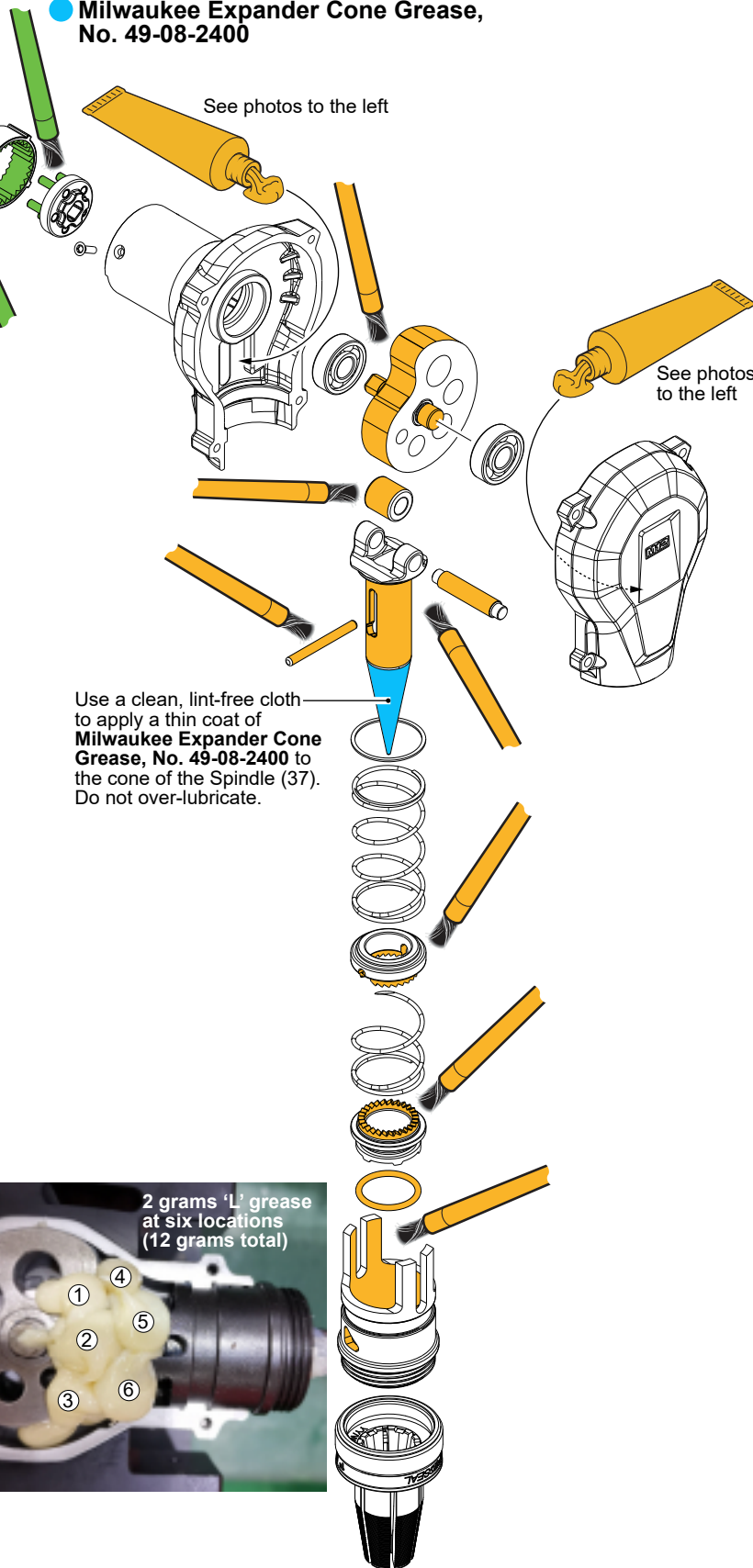
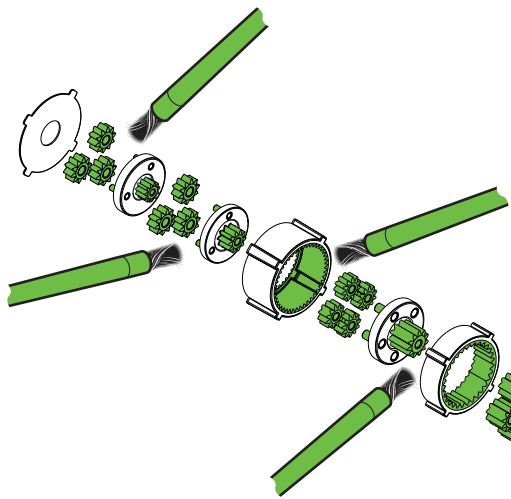

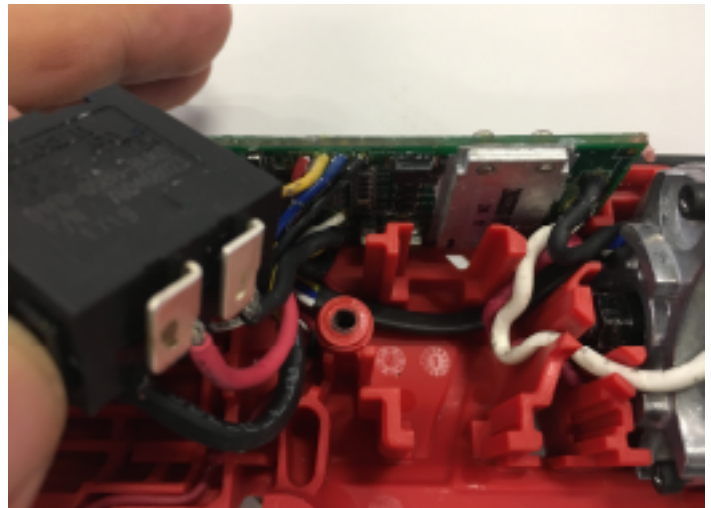
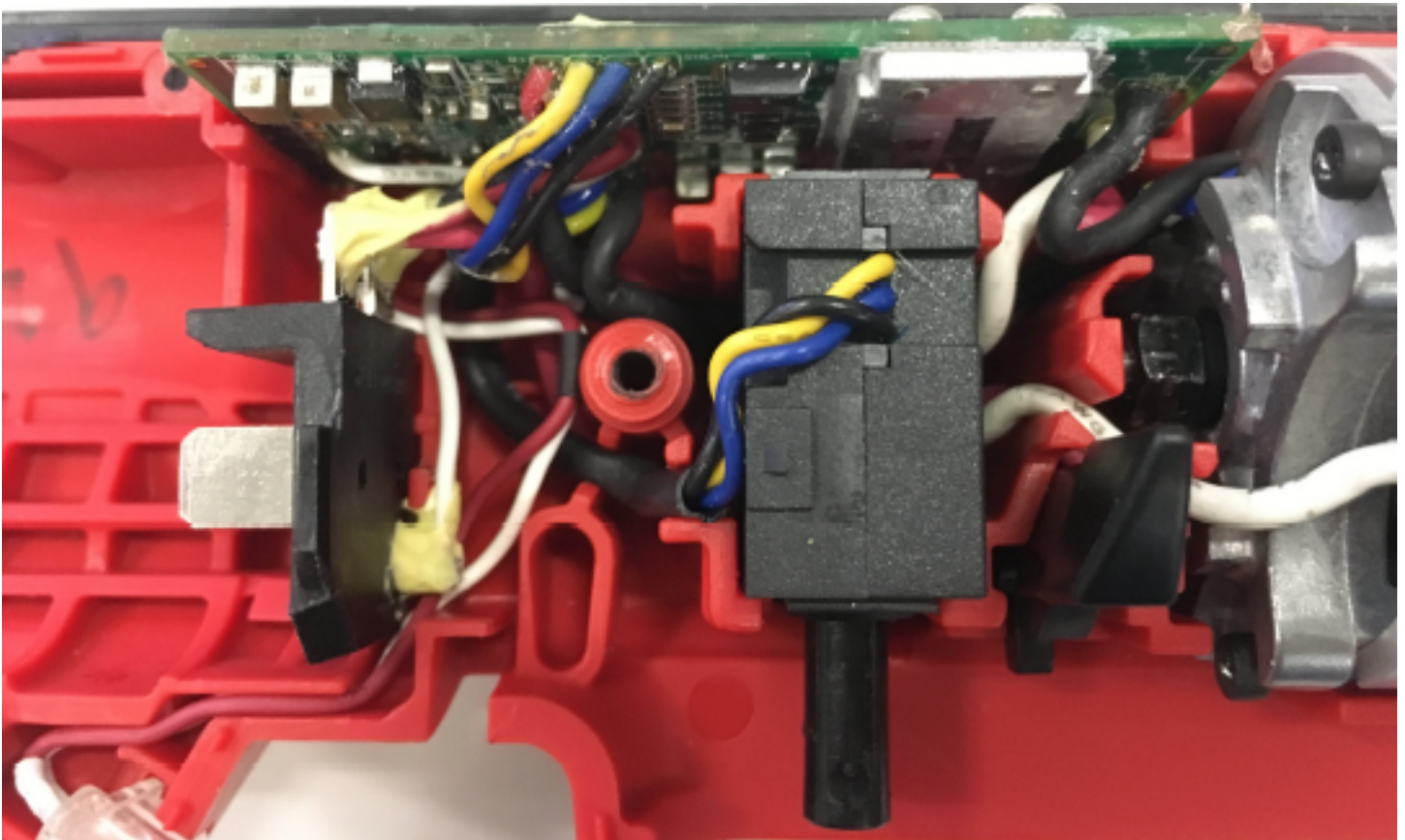

NOTE: Be sure to place all components of the Electronics Assembly (64) firmly and squarely in Left Housing Halve-Support (55). Be sure to route wires into wire traps as shown. Check for any interferences prior to installing the Housing Cover (51).

SCREW TORQUE SPECIFICATIONS			SEAT TORQUE	
FIG.	PART NO.	WHERE USED	(KG/CM)	(IN/LBS)
1	05-55-0047	Flange Nut-Rotor	20-24	17-20
2	05-84-0200	Motor Plate	5-7	4-6
6	06-82-2310	Bearing Plate	11-13	9-11
27	05-81-0105	Motor Housing	9-13	8-11
34	06-82-5320	Gear Case Cover	25-30	21-26
46	06-82-6351	Housing Halves	6-9	5-8
47	06-82-4003	Housing Halves	10-15	8-13