

Pre-adjustable filling units

553 Series

© Copyright 2018 Caleffi

Function

The automatic filling valve is a device consisting of a pressure reducing valve with compensating seat, visual system pressure setting indicator, an inlet filter, anti-scale internal parts, a shut-off valve and a check valve.

It is installed on the water inlet piping in sealed heating systems, and its main function is to maintain the pressure of the system stable at a set value, automatically filling up with water as required.

This valve has been designed as pre-adjustable, which means that it can be adjusted at the required pressure value before the system charging phase.

After installation, during the filling or topping-off phase, the water feed will stop when the set pressure is reached filling 50% faster than other valves. There are no levers to flip or valve to close.

Pre-assembled with the 573 series backflow preventer, the AutoFill™ Combo features an atmospheric vent which is designed to protect drinking water systems from return flow, caused by back-siphoning or back pressure, of contaminated fluids. The 573 series has been specifically certified to standards CSA B64.3 and ASSE 1012.

These items are designed for use in closed hydronic systems. Do not use in plumbing applications. These items do not meet the low-lead plumbing standards of U.S. and Canada.

Product Range

553



- 553542A 1/2" M NPT inlet x 1/2" FNPT outlet
- 553549A 1/2" sweat inlet x 1/2" FNPT outlet
- 553642A 1/2" M NPT inlet x 1/2" FNPT outlet / gauge
- 553649A 1/2" sweat inlet x 1/2" FNPT outlet / gauge



Technical Specifications

Filling unit

Materials - body: brass
 - cover: PA 66 GF 30
 - seals: NBR

Performance

Suitable fluids: water, glycol solution
 Max. percentage of glycol: 50%
 Max. working pressure: 230 psi (16 bar)
 Pressure setting range: 3-60 psi (0.2-4 bar)
 Factory setting: 15 psi (1.035 bar)
 Indicator accuracy: ±2 psi (±0.15 bar)
 Max. working temperature: 150°F (65°C)
 Pressure gauge scale: 0-60 psi / 0-6 bar

Connections - 553542A 1/2" NPT male inlet x 1/2" NPT female outlet
 - 553549A 1/2" sweat inlet x 1/2" NPT female outlet
 - 553642A 1/2" NPT male inlet x 1/2" NPT female outlet
 - 553649A 1/2" sweat inlet x 1/2" NPT female outlet



SAFETY INSTRUCTION

This safety alert symbol will be used in this manual to draw attention to safety related instructions. When used, the safety alert symbol means **ATTENTION! BECOME ALERT! YOUR SAFETY IS INVOLVED! FAILURE TO FOLLOW THESE INSTRUCTIONS MAY RESULT IN A SAFETY HAZARD.**



WARNING: This product can expose you to chemicals including lead, which is known to the State of California to cause cancer and birth defects or other reproductive harm. For more information go to www.P65Warnings.ca.gov.



CAUTION: All work must be performed by qualified personnel trained in the proper application, installation, and maintenance of systems in accordance with all applicable codes and ordinances.



CAUTION: If the automatic filling unit is not installed, commissioned and maintained properly, according to the instruction contained in the manual, it may not operate correctly and may endanger the user.



CAUTION: Make sure that all the connecting pipework is water tight.



CAUTION: When making the water connections, make sure that the unit connecting pipework is not mechanically over-stressed. Over time this could cause breakages, with consequent water losses which, in turn, could cause harm to property and/or people.



CAUTION: In the case of highly aggressive water, arrangements must be made to treat the water before it enters the unit, in accordance with current legislation. Otherwise the unit may be damaged and will not operate correctly.

LEAVE THIS MANUAL FOR THE USER



CONSIGNE DE SÉCURITÉ

Ce symbole d'avertissement servira dans ce manuel à attirer l'attention sur la sécurité concernant instructions. Lorsqu'il est utilisé, ce symbole signifie.

ATTENTION! DEVEZ-VOUS ÊTRE ALERTES ! VOTRE SÉCURITÉ EST EN JEU ! NE PAS SUIVRE CES INSTRUCTIONS PEUT PROVOQUER UN RISQUE DE SÉCURITÉ.



AVERTISSEMENT: Ce produit peut vous exposer à des produits chimiques comme le plomb, qui est connu dans l'État de Californie pour causer le cancer, dommages à la naissance ou autre. Pour plus d'informations rendez-vous www.P65Warnings.com.



ATTENTION: Tous les travaux doivent être effectués par du personnel qualifié formé à la bonne application, installation et maintenance des systèmes conformément aux codes et règlements locaux.



ATTENTION: Si le réducteur de pression, Série 535H, n'est pas installé, mis en service et entretenu correctement, selon les instructions contenues dans ce manuel, il peut ne pas fonctionner correctement et peut mettre en danger l'utilisateur.



ATTENTION: S'assurer que tous les raccords sont étanches.



ATTENTION: Lorsque vous effectuez les raccords d'eau, assurez-vous que la tuyauterie reliant le réducteur de pression n'est pas mécaniquement overstressed. Au fil du temps, ceci pourrait causer des ruptures, avec pour conséquence des pertes en eau qui, à leur tour, peuvent causer des dommages à la propriété et/ou les gens.



ATTENTION: Dans le cas de l'eau très agressive, des dispositions doivent être prises pour traiter l'eau avant qu'elle entre dans l'unité, conformément à la législation. Sinon l'appareil peut être endommagé et ne fonctionner pas correctement.

LAISSEZ CE MANUEL AVEC L'UTILISATEUR

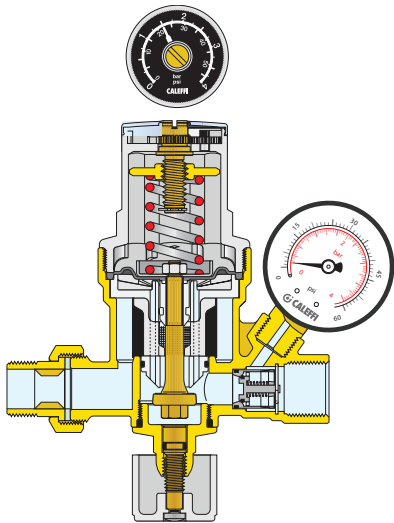

Construction details

Pre-calibration

This model is equipped with a pressure setting indicator for the commissioning operation. The system charge pressure can be input by means of the adjusting screw, before the start of the system filling phase.

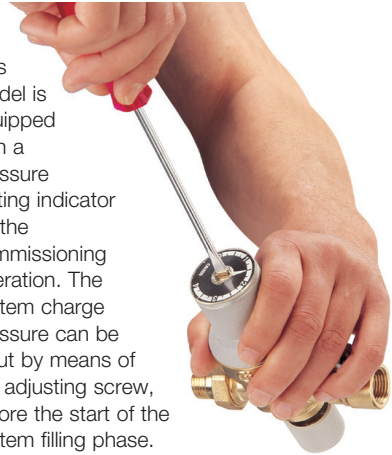

Removable filter cartridge

The cartridge containing the operating mechanisms, protected by a large surface area strainer, is removable. This makes it very easy and quick to carry out inspections, internal cleaning and even replacement of the cartridge itself. Water intake is proportional to the air vented from the system.

Installation

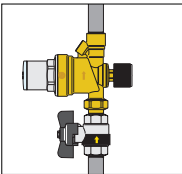

1. Filling unit can be installed in either horizontal or vertical position. It is, however, vital that the unit is not installed upside down.

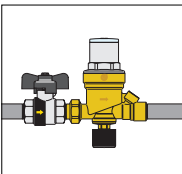

2. The special method of mechanical pre-adjustment with pressure setting indicator makes it possible to set the unit to the required value in the system before the beginning of the filling phase.

3. The unit is normally set at a pressure not less than that obtained by adding the hydrostatic pressure and 4 psi (0,3 bar).

4. During filling, the internal mechanism will automatically regulate the pressure until it reaches the required value, **without the need to oversee the filling operation itself**. This prevents the system being charged to a higher pressure than required.

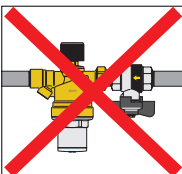

5. Given the pre-calibrating function, the presence of the downstream pressure gauge is not essential.

6. When the system is filled, the shut-off valve can be closed. In order to restore the automatic topping-off condition, merely re-open the valve. The pressure in the system will gradually return to the set pressure.

Dimensions

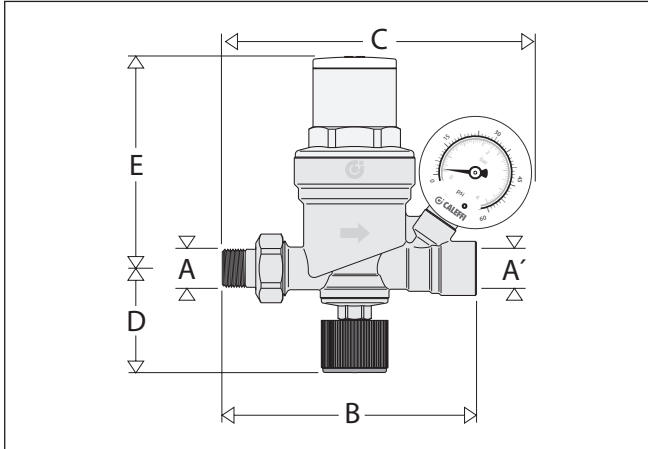

Code	A	A'	B	C	D	E
553542A	1/2" NPT	1/2" NPT	4 3/4"	—	1 5/16"	4"
553549A	1/2" SWT	1/2" NPT	4 3/4"	—	1 5/16"	4"
553642A	1/2" NPT	1/2" NPT	4 3/4"	5 3/4"	1 5/16"	4"
553649A	1/2" SWT	1/2" NPT	4 3/4"	5 3/4"	1 5/16"	4"

Maintenance

For cleaning, inspection or replacement of the entire cartridge, proceed as follows:

1. Isolate the unit.
2. Open the lower control knob.
3. Unscrew the adjusting screw until it stops.
4. Remove the upper cover.
5. Extract the cartridge using pliers.
6. The entire unit, after inspection, can be reassembled or replaced using a spare cartridge.
7. Re-adjust the equipment.

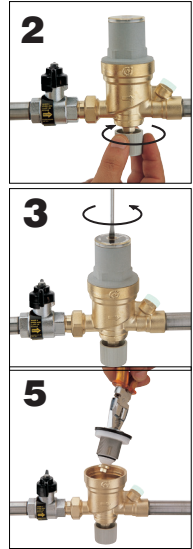

Replacement parts



NA10363

Replacement gauge 0-60 psi/0-4 bar, 1/4" NPT



F59650

AutoFill™ 553 series replacement cartridge



NA10197

AutoFill™ clear plastic disc cover

Application diagram

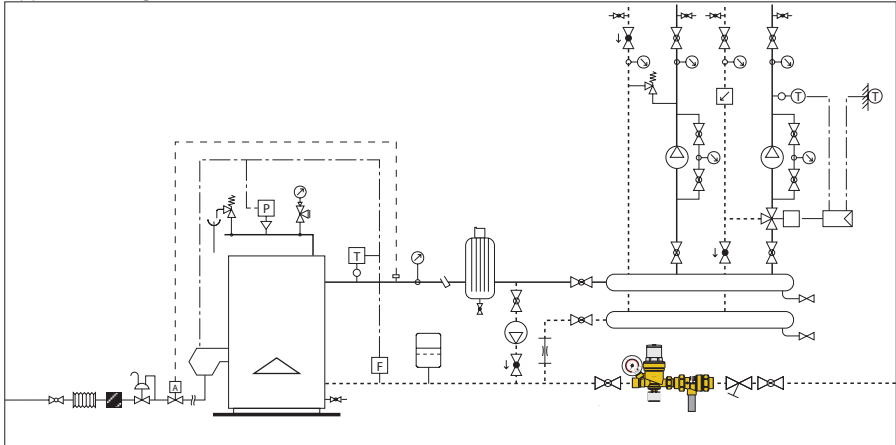

	Shut-off valve		Pump		3-way valve		Fuel shut-off valve
	Ball valve		FlowCal™		Pressure switch		Anti-vibration joint
	BALLSTOP		Flow meter		Control pocket		Sensor pocket
	Thermometer		Temperature probe		Gas filter		Safety valve
	Differential by-pass valve		Safety thermostat		Gas regulator		Y-strainer
	Flow switch		Regulator		Air separator		
	Zone valve		Expansion vessel				

Scan to view



553 AutoFill™

Installation Tip



Caleffi North America, Inc.
3883 West Milwaukee Road
Milwaukee, WI 53208
T: 414.238.2360 F: 414.238.2366

7-23-18