

Technical Data Manual

Model Nos. and pricing: see Price List

VIESSMANN®

For Natural Gas and Liquid Propane Gas
Gas-fired wall-mounted condensing boiler
12 to 285 MBH (3.5 to 83.5 kW)
Multi-boiler installation 480 to 2280 MBH
for models 45, 60, 80 and 285



VITODENS® 200-W



Product may not be exactly as shown

Vitodens 200-W Series B2HA, Models 19, 28, 35, 45, 60, 80, 285

Gas-Fired Wall-Mounted Condensing Boiler with modulating Matrix cylinder burner for room air independent operation (using a direct vent system) or room air dependent operation.



Vitodens 200-W

Equipped with the industry's first intelligent combustion management system and powerful control technology, the new generation Vitodens 200-W gas-fired wall-mount condensing boiler delivers unparalleled performance, reliability and comfort.

The benefits at a glance:

- Best value in its class with new industry-leading technology and the most standard features.
- Highest Efficiency up to 98% at full modulation and up to 93.3% A.F.U.E.
- Lasting performance with industry-leading Viessmann made SA240 / S43932 stainless steel Inox-Radial heat exchanger constructed to CSA B51 and ASME Section IV.
- Low Emission Combustion with Viessmann made stainless steel MatriX cylinder burner. Factory calibrated.
- Fast Installation and Reduced Maintenance with Lambda Pro, industry-first intelligent combustion management system: Adjusts automatically to gas type and quality. No fuel conversion kit required.
- Powerful and User-friendly
Viessmann Vitotronic on-board multi-function outdoor reset boiler and system control for multi-temperature space and DHW heating.
- Expanded Application Range with increased capacity up to 285 MBH (83 kW). Multi-boiler installation up to 2280 MBH (668 kW) with up to 8 boilers (models B2HA 45, 60, 80, 285).
- Greater Venting Flexibility with increased vent length up to 180 ft. (55 m) and multiple venting options.
 - Horizontal or vertical sealed combustion coaxial venting (field supplied).
 - Horizontal, vertical or hybrid sealed combustion double-pipe venting (field supplied).
 - Horizontal or vertical single-wall venting (field supplied).
- Compact, Esthetic Product Design and zero clearance to combustibles.
- Extremely Quiet Operation; quieter than most refrigerators.
- True High-Altitude Operation up to 10,000 ft. (3,000 m) with simple electronic adjustment.
- Efficiency up to 98% through intensive condensation. The flue gas temperature is only approximately 9-27°F (5-15°C) above boiler return temperature (see chart below).

Cross-Section

Vitodens 200-W B2HA 19, 28, 35, 45, 60, 80, 285

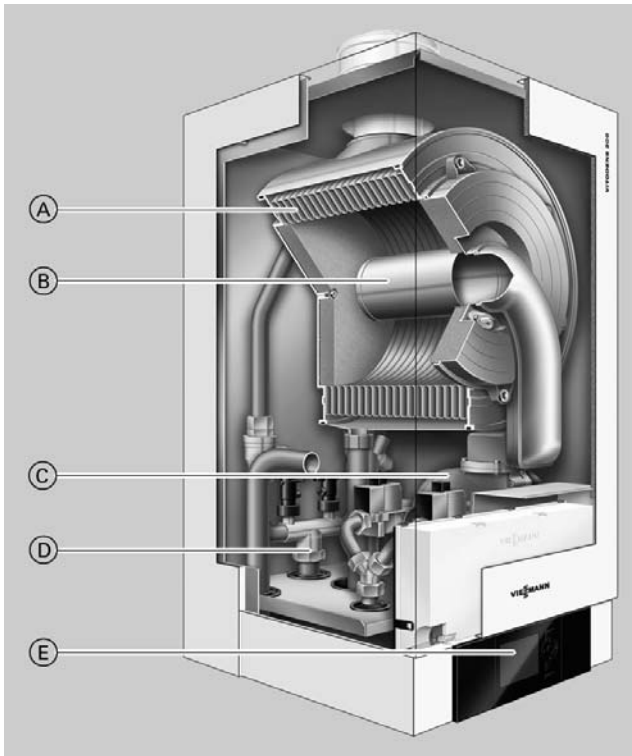

- Ⓐ Inox-Radial heat exchanger made from stainless steel – for high operational reliability and a long service life. Large heating output in the smallest of spaces
- Ⓑ Modulating MatriX cylinder burner for extremely clean combustion and quiet operation
- Ⓒ Variable speed combustion fan for quiet and economical operation
- Ⓓ Gas and water connections
- Ⓔ Digital boiler control unit

Delivered condition

Wall mounted gas condensing boiler with Inox-Radial heat exchanger, modulating MatriX cylinder burner for natural gas and LPG, plus wall mounting bracket. Vitotronic 200 for weather-compensated operation. Preset for operation with natural gas. Fully plumbed and wired. White epoxy-coated casing.

Product may not be exactly as shown

The flue gas temperature is only approximately 9-27°F (5-15°C) above boiler return temperature (see chart below).

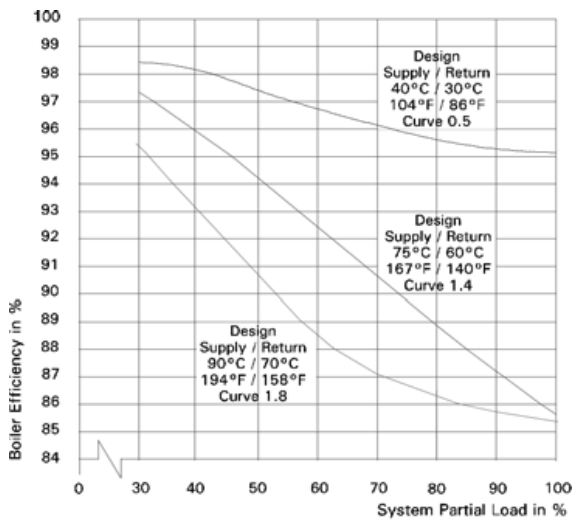

Vitodens 200-W boiler efficiency dependent on system heating water return temperatures and load conditions

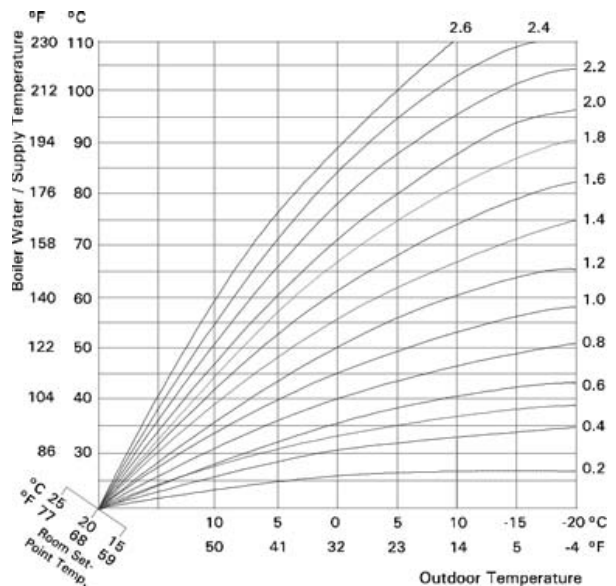

Technical Data

Boiler Model No. 200-W B2HA		19	28	35	45	60	80, 285
CSA input Natural Gas (NG)	MBH	12-67	19-100	19-125	60-160	60-212	71-285
	(kW)	(3.5-20)	(5.5-29)	(5.5-37)	(17.5-47)	(17.5-62)	(21-83)
CSA input Liquid Propane Gas (LPG)	MBH	12-67	19-100	19-125	60-160	60-212	104-285
	(kW)	(3.5-20)	(5.5-29)	(5.5-37)	(17.5-47)	(17.5-62)	(30-83)
CSA output/DOE *1 heating capacity NG	MBH	10.9-61	17.4-91.2	17.4-114	55-146	55-194	65-260
	(kW)	(3.2-18)	(5-27)	(5-33)	(16-43)	(16-57)	(19-76)
CSA output/DOE *1 heating capacity LPG	MBH	10.9-61	17.4-91.2	17.4-114	55-146	55-194	95-260
	(kW)	(3.2-18)	(5-27)	(5-33)	(16-43)	(16-57)	(28-76)
Net AHRI rating *2	MBH	53	79.3	99	127	169	226
	(kW)	(15.5)	(23.2)	(29)	(37)	(49.5)	(66.2)
Heat exchanger surface area	ft. ²	10.89	10.89	10.89	15.76	15.76	28.88
	(m ²)	(1.01)	(1.01)	(1.01)	(1.46)	(1.46)	(2.68)
Min. gas supply pressure							
Natural gas	"w.c.	4	4	4	4	4	4
Liquid propane gas	"w.c.	10	10	10	10	10	10
Max. gas supply pressure *3							
Natural gas	"w.c.	14	14	14	14	14	14
Liquid propane gas	"w.c.	14	14	14	14	14	14
A.F.U.E.	%	93.3	93.3	93.3	92.0	92.0	92.0
Weight	lbs	101	106	106	155	155	194
	(kg)	(46)	(48)	(48)	(72)	(72)	(88)
Boiler water content	USG	0.87	0.87	0.87	1.9	1.9	3.4
	(L)	(3.27)	(3.27)	(3.27)	(7.0)	(7.0)	(12.8)
Boiler max. flow rate *4	GPM	6.2	6.2	6.2	15.4	15.4	25
	(L/h)	(1400)	(1400)	(1400)	(3500)	(3500)	(5700)
Max. operating pressure at 210°F (99°C)	psig	45	45	45	60	60	60
	(bar)	(3)	(3)	(3)	(4)	(4)	(4)
Boiler water temperature							
- Adjustable high limit (AHL) range space heating (steady state)	°F	68 to 165	68 to 165	68 to 165	68 to 165	68 to 165	68 to 185
	(°C)	(20 to 74)	(20 to 74)	(20 to 74)	(20 to 74)	(20 to 74)	(20 to 85)
DHW production	°F	165	165	165	165	165	185
	(°C)	(74)	(74)	(74)	(74)	(74)	(85)
- Fixed high limit (FHL)	°F (°C)	210 (99)	210 (99)	210 (99)	210 (99)	210 (99)	210 (99)
Boiler connections							
Boiler heating supply and return Pressure relief valve Drain valve	NPTM"	¾	¾	¾	1½	1½	1½
	NPTF"	¾	¾	¾	¾	¾	¾
	(male thread)	¾	¾	¾	¾	¾	¾
Boiler supply/return for indirect-fired DHW storage tank (field supplied)	NPT"	¾	¾	¾	1½	1½	1½
Gas valve connection	NPTF"	¾	¾	¾	1	1	1

*1 Output based on 140°F (60°C), 120°F (49°C) system supply/return temperature.

*2 Net AHRI rating based on piping and pick-up allowance of 1.15.

*3 If the gas supply pressure exceeds the maximum gas supply pressure value, a separate gas pressure regulator must be installed upstream of the heating system.

*4 See "Waterside Flow" starting on page 10 in this manual.

Technical Data

Boiler Model No. 200-W B2HA		19	28	35	45	60	80, 285
Dimensions							
Overall depth	inches (mm)	14 (360)	14 (360)	14 (360)	15 (380)	15 (380)	21 (530)
Overall width	inches (mm)	17¾ (450)	17¾ (450)	17¾ (450)	19 (480)	19 (480)	19 (480)
Overall height	inches (mm)	41 (1040)	41 (1040)	41 (1040)	40 ⁵ / ₈ (1031)	40 ⁵ / ₈ (1031)	43½ (1105)
Flue gas *5							
Temperature (at boiler return temperature of 86°F (30°C))							
- at rated full load	°F (°C)	113 (45)	113 (45)	113 (45)	95 (35)	104 (40)	95 (35)
- at rated partial load	°F (°C)	95 (35)	95 (35)	95 (35)	91 (33)	95 (35)	91 (33)
Temperature (at boiler return temperature of 140°F (60°C))	°F (°C)	154 (68)	154 (68)	154 (68)	149 (65)	158 (70)	149 (65)
Flue gas parameters							
Mass flow rate							
Natural gas							
- at rated heating output (DHW heating)	lb/h (kg/h)	70.1 (31.8)	96.8 (43.9)	129.4 (58.7)	172 (78)	229 (104)	306 (139)
- at partial load	lb/h (kg/h)	12.1 (5.5)	19.2 (8.7)	19.2 (8.7)	66 (30)	66 (30)	115 (52)
Liquid propane gas							
- at rated heating output (DHW heating)	lb/h (kg/h)	66.6 (30.2)	91.9 (41.7)	122.8 (55.7)	163 (74)	218 (99)	291 (132)
- at partial load	lb/h (kg/h)	16.8 (7.6)	30.9 (14.0)	30.9 (14.0)	62 (28)	62 (28)	108 (49)
Max. condensate flow rate *6							
with natural gas and T _S /T _R = 122/86°F (50/30°C)	USG/h (L/h)	0.66 (2.5)	0.97 (3.7)	1.21 (4.6)	1.55 (5.9)	2.0 (7.9)	2.77 (10.5)
Condensate connection *7							
hose nozzle	Ø in	¾-1	¾-1	¾-1	¾-1	¾-1	¾-1
Boiler flue gas connection *8							
Ø in (mm)		2 ³ / ₈ (60)	2 ³ / ₈ (60)	2 ³ / ₈ (60)	3¼ (80)	3¼ (80)	4 ³ / ₈ (110)
Combustion air supply connection (coaxial)							
outer Ø in (mm)		4 (100)	4 (100)	4 (100)	5 (125)	5 (125)	6 (150)
Sound Rating							
- at maximum input	dB	41	48	51	56	67	56
- at minimum input	dB	35	36	36	39	39	38
NOx @ 3% O ₂		N/A					< 20 PPM *9

*5 Measured flue gas temperature with a combustion air temperature of 68°F (20°C).

*6 Based on maximum input rate.

*7 Requires 1 inch (25 mm) tubing. See the Installation Instructions of the Vitodens 200-W, B2HA for details.

*8 For side wall vent installations (coaxial system):

Do not exceed max. equivalent length specified in the Installation Instructions of the Vitodens 200-W, B2HA Venting System.

Side wall co-axial vent installation must include Viessmann protective screen!

For details refer to the Installation Instructions for the Vitodens 200-W, B2HA Venting System.

The Vitodens 200-W can only be common vented with other Vitodens 200-W boilers of the same size and series (Vitodens 200-W B2HA 19, 28, 35 cannot be common vented).

For information regarding other Viessmann System Technology componentry, please reference documentation of respective product.

*9 Optional low NOx certified by SCAQMD Natural Gas models available.

Note: For high altitude installation at 10,000 ft. the input for model B2HA 19-80, 285 will have an altitude de-ration of 21%.

Models 200-W, B2HA 19, 28, 35

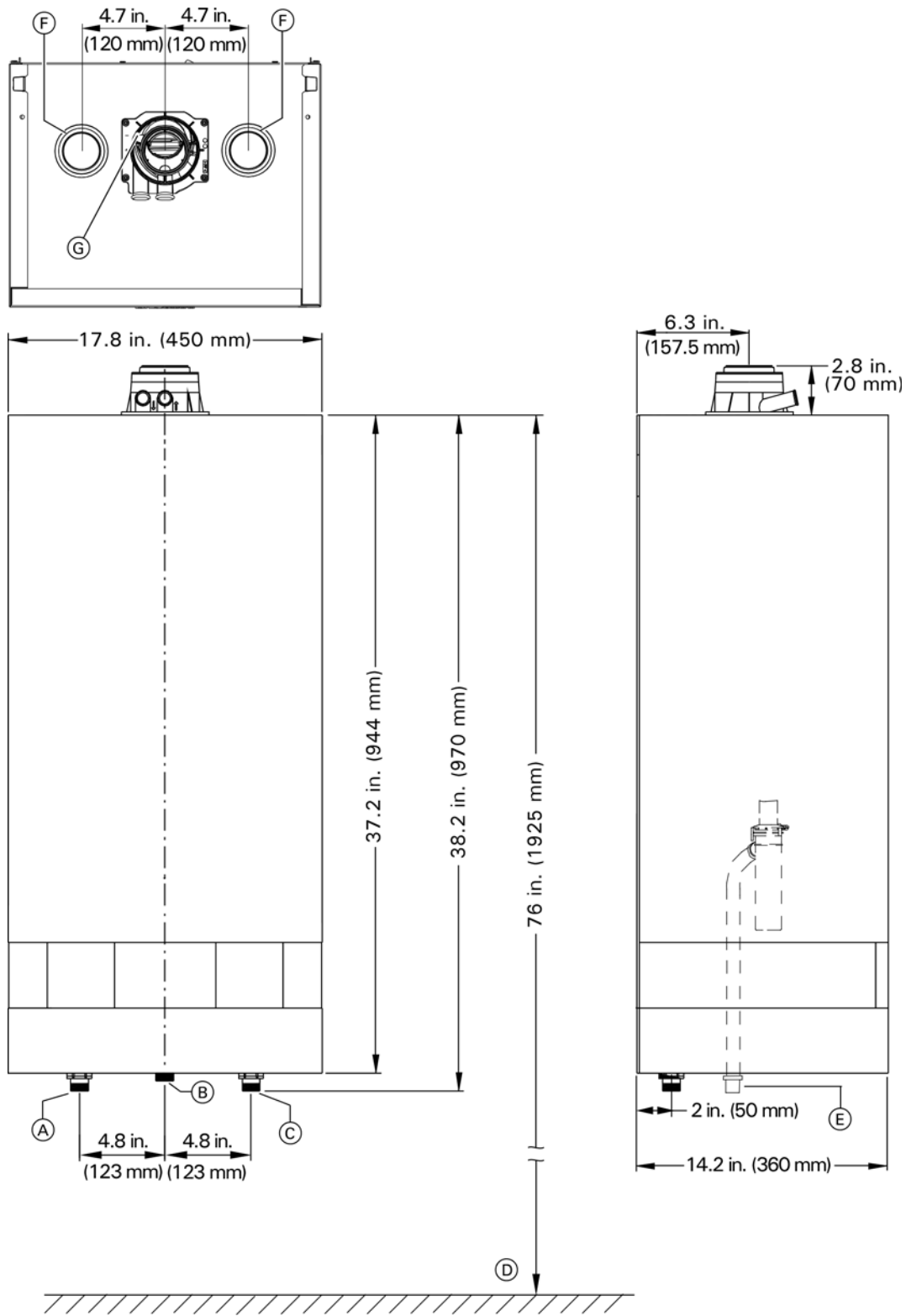

Legend

- (A) Boiler Supply
- (B) Gas Connection, 3/4" NPTF
- (C) Boiler Return
- (D) Recommended height (single boiler system)
- (E) Condensate drain
- (F) Combustion air intake (left or right)
- (G) Combustion air intake (through co-axial)

Models 200-W, B2HA 45, 60

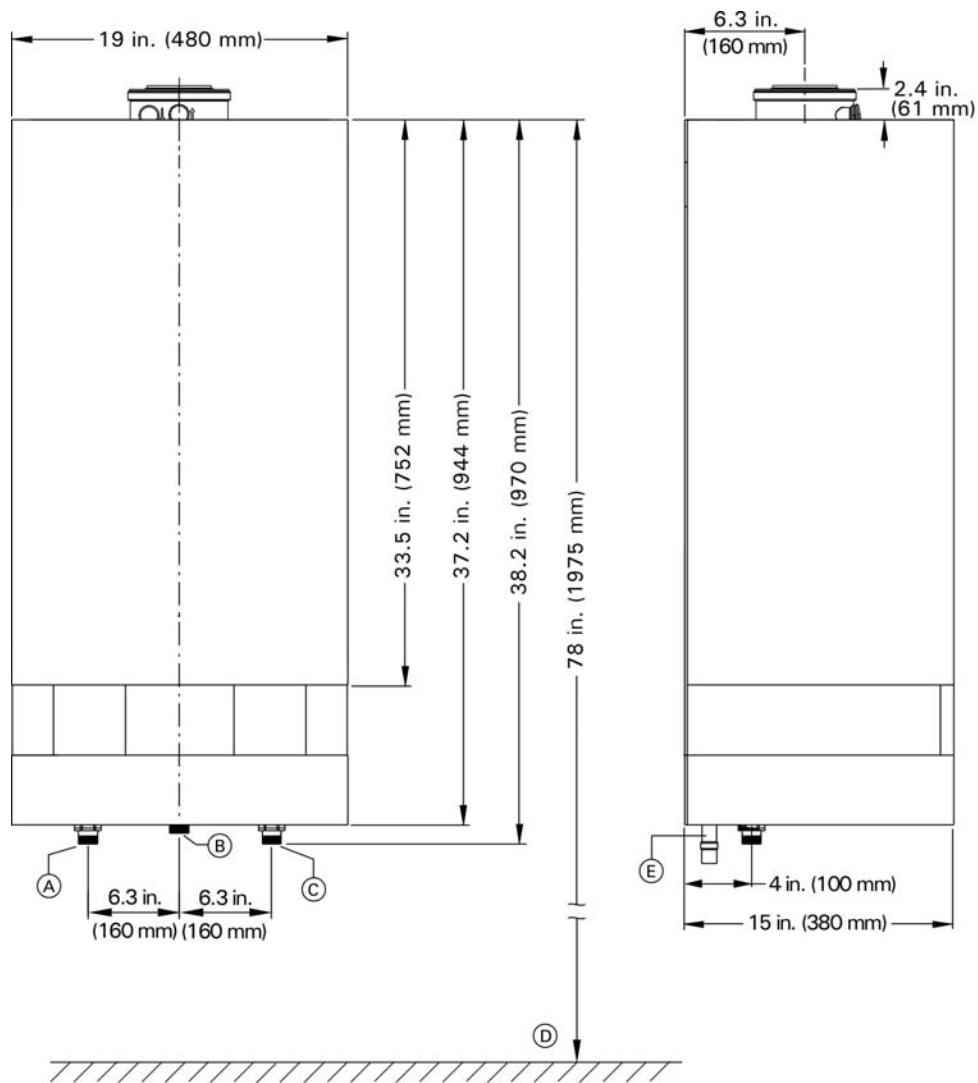

Legend

- (A) Boiler Supply
- (B) Gas Connection, 1" NPTF
- (C) Boiler Return
- (D) Recommended height (single boiler system)
- (E) Condensate drain

Model B2HA 80, 285

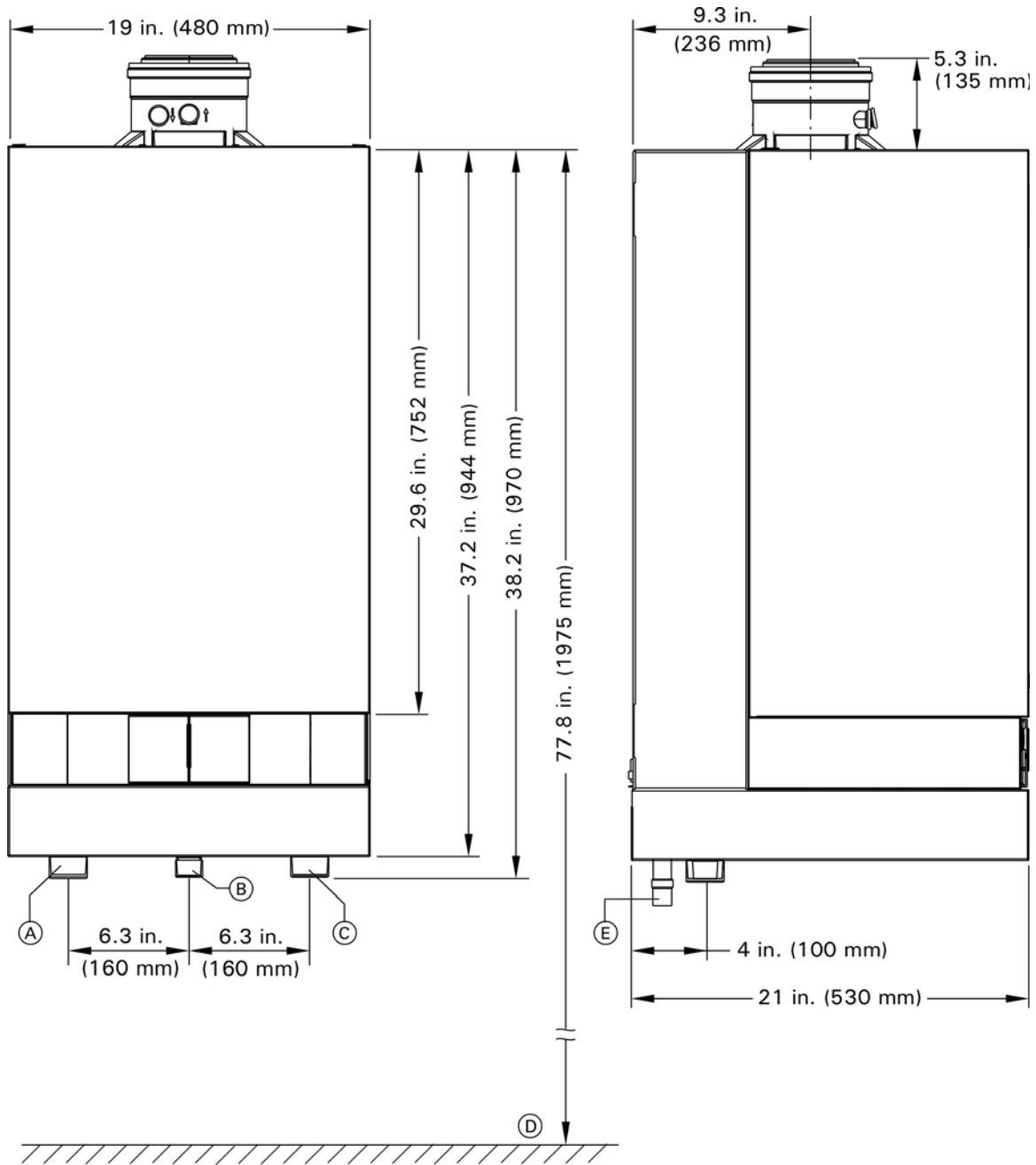

Legend

- (A) Boiler Supply
- (B) Gas Connection, 1" NPTF
- (C) Boiler Return
- (D) Recommended height (single boiler system)
- (E) Condensate drain

Recommended Minimum Service Clearances

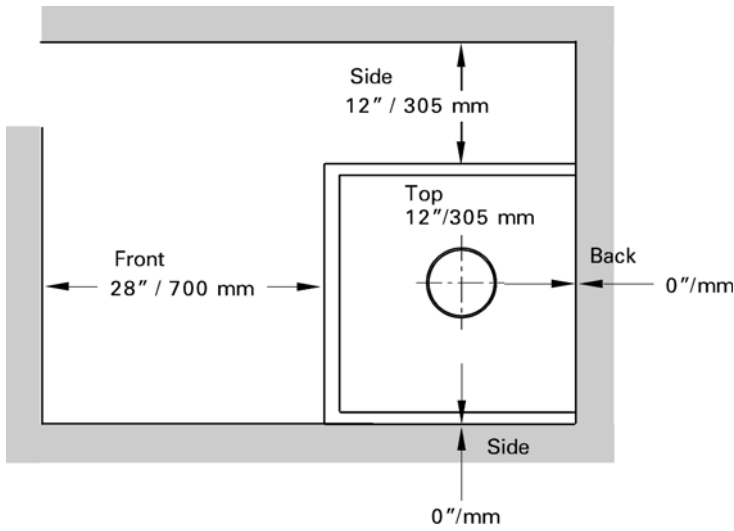

Minimum Clearances to Combustibles

Top	Front	Rear	Left	Right	Vent pipe * 1
0	0 AL, CL	0	0	0	0

AL = Alcove
 CL = Closet

* 1 Refer to the Installation Instructions of the Vitodens 200-W, B2HA Venting System for details.

Note: The Vitodens boiler has passed the zero inches vent clearance to combustibles testing requirements dictated by the Harmonized Standard ANSI Z21.13. CSA 4.9.2000 and therefore is listed for zero clearance to combustibles when vented with a single wall special venting system (AL-29-4C material). The zero inches vent clearance to combustibles for the Vitodens boiler supercedes the clearance to combustibles listing that appears on the special venting system label.

Waterside Flow (primary circuit)

The Vitodens 200-W, B2HA is designed for closed loop, forced circulation hot water heating systems only. Use standard friction loss method for pipe sizing. Observe boiler maximum and minimum flow rate limitations. If system flow rate exceeds boiler maximum flow rate (as stated above), falls below the minimum flow rate or if system flow rate is unknown, Viessmann strongly recommends the installation of a low-loss header. An alternative method may be used, such as primary secondary piping using closely spaced tees.

A low-loss header offers additional benefits not provided by a pair of closely spaced tees. Viessmann therefore strongly recommends and prefers the use of a low-loss header over closely spaced tees. See pages 32 and 33 for low-loss header information. Once the low-loss header is connected, the built-in low-loss header logic of the Vitodens 200-W boiler ensures the required Δt across the system through the sensory communication between the low-loss header and the boiler.

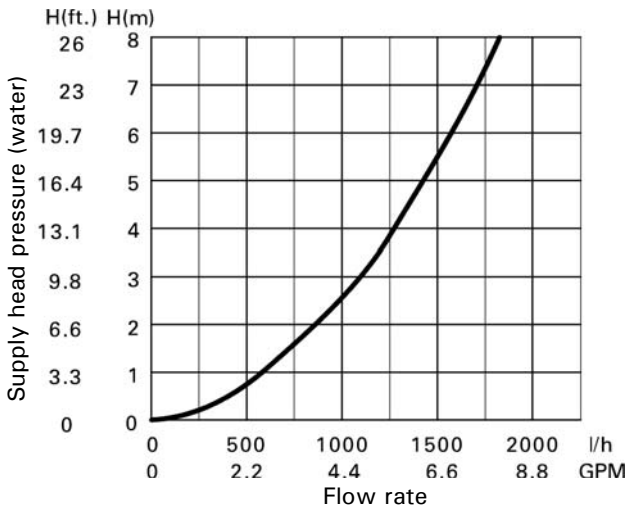

Pressure drop (primary circuit) for Vitodens 200-W, B2HA 19, 28, 35
For sizing an on-site circulation system.
Max. flow rate: 6.2 GPM (1400 L/h)

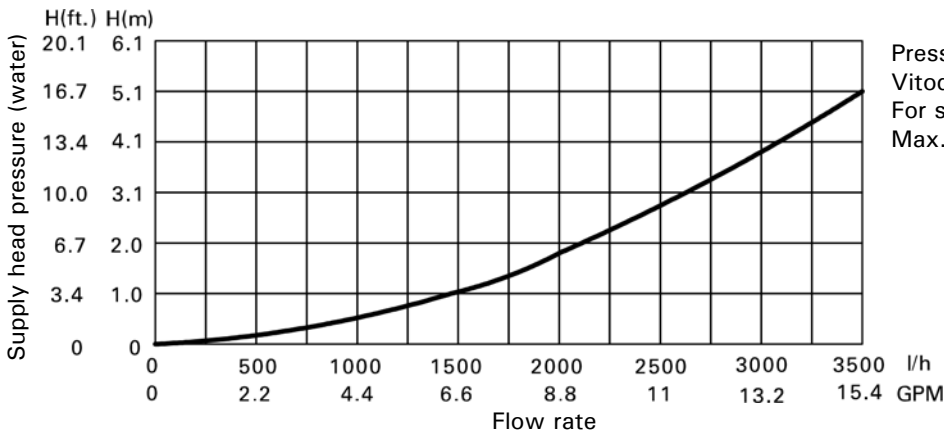

Pressure drop (primary circuit) for Vitodens 200-W, B2HA 45, 60
For sizing an on-site circulation system.
Max. flow rate 15.4 USGPM (3500 L/h)

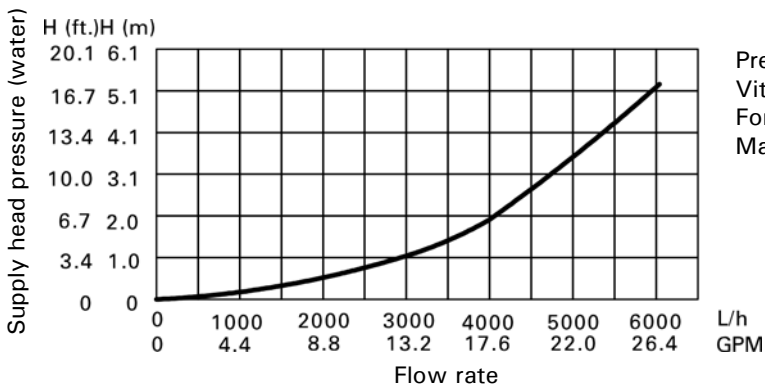

Pressure drop (primary circuit) for Vitodens 200-W, B2HA 80, 285
For sizing an on-site circulation system.
Max. flow rate 25 USGPM (5700 L/h)

Typical System Flow Rates

Boiler maximum flow rate 6.2 GPM (1400 L/h)

Model B2HA 19		1 boiler
Output (NG/LPG)		
	MBH	61
Δt for NG/LPG		
20° F rise	GPM (L/h)	6.1 (1385)
25°F rise	GPM (L/h)	4.9 (1113)
30°F rise	GPM (L/h)	4.0 (909)
35°F rise	GPM (L/h)	3.5 (795)
40°F rise	GPM (L/h)	3.1 (704)

Boiler maximum flow rate 6.2 GPM (1400 L/h)

Model B2HA 28		1 boiler
Output (NG/LPG)		
	MBH	91.2
Δt for NG/LPG		
20° F rise	GPM (L/h)	9.1 (2100)
25°F rise	GPM (L/h)	7.3 (1700)
30°F rise	GPM (L/h)	6.1 (1400)
35°F rise	GPM (L/h)	5.2 (1200)
40°F rise	GPM (L/h)	4.6 (1000)

Boiler maximum flow rate 6.2 GPM (1400 L/h)

Model B2HA 35		1 boiler
Output (NG/LPG)		
	MBH	114
Δt for NG/LPG		
20° F rise	GPM (L/h)	11.4 (2589)
25°F rise	GPM (L/h)	9.1 (2067)
30°F rise	GPM (L/h)	7.6 (1726)
35°F rise	GPM (L/h)	6.5 (1476)
40°F rise	GPM (L/h)	5.7 (1295)

Typical System Flow Rates

Boiler maximum flow rate 15.4 GPM (3500 L/h)

Model B2HA 45		1 boiler	2 boilers	3 boilers	4 boilers	5 boilers	6 boilers	7 boilers	8 boilers
Output (NG/LPG)									
	MBH	146	292	438	584	730	876	1022	1168
Δt for NG/LPG									
20°F rise	GPM (L/h)	14.6 (3316)	29.2 (6632)	43.8 (9949)	58.4 (13265)	73 (16580)	87.6 (19898)	102.2 (23214)	116.8 (26530)
25°F rise	GPM (L/h)	11.7 (2653)	23.4 (5306)	35 (7959)	46.7 (10612)	58.4 (13264)	70.1 (15918)	81.8 (18571)	93.4 (21224)
30°F rise	GPM (L/h)	9.7 (2211)	19.5 (4421)	29.2 (6633)	39 (8843)	48.7 (11053)	58.4 (13265)	68.1 (15476)	78 (17687)
35°F rise	GPM (L/h)	8.3 (1805)	16.7 (3790)	25 (5685)	33.4 (7580)	41.7 (9474)	50.1 (11370)	58.4 (13265)	66.7 (15160)
40°F rise	GPM (L/h)	7.3 (1658)	14.6 (3316)	22 (4974)	29.2 (6632)	36.5 (8290)	43.8 (9949)	51.1 (11607)	58.4 (13265)

Boiler maximum flow rate 15.4 GPM (3500 L/h)

Model B2HA 60		1 boiler	2 boilers	3 boilers	4 boilers	5 boilers	6 boilers	7 boilers	8 boilers
Output (NG/LPG)									
	MBH	194	388	582	776	970	1164	1358	1552
Δt for NG/LPG									
20°F rise	GPM (L/h)	19.4 (4406)	38.8 (8813)	58.2 (13220)	77.6 (17626)	97 (22031)	116.4 (26439)	135.8 (30846)	155.2 (35252)
25°F rise	GPM (L/h)	15.5 (3525)	31 (4050)	46.6 (10576)	62 (14101)	77.6 (17625)	93.1 (21151)	108.6 (24677)	124.2 (28202)
30°F rise	GPM (L/h)	12.9 (2937)	26 (5875)	38.8 (8813)	51.7 (11750)	64.7 (14687)	77.6 (17626)	90.5 (20564)	103.5 (23502)
35°F rise	GPM (L/h)	11.1 (2518)	22.2 (5036)	33.3 (7554)	44.3 (10072)	55.4 (12589)	66.5 (15108)	77.6 (17626)	88.7 (20144)
40°F rise	GPM (L/h)	9.7 (2203)	19.4 (4406)	29 (6610)	38.8 (8813)	48.5 (11015)	58.2 (13220)	68 (15423)	77.6 (17626)

Boiler maximum flow rate 25 GPM (5700 L/h)

Model B2HA 80, 285		1 boiler	2 boilers	3 boilers	4 boilers	5 boilers	6 boilers	7 boilers	8 boilers
Output (NG/LPG)									
	MBH	260	520	780	1040	1300	1560	1820	3960
Δt for NG/LPG									
20°F rise	GPM (L/h)	26.0 (5905)	52 (11811)	78 (17717)	104 (23223)	130 (29526)	156 (35434)	182 (41340)	208 (47246)
25°F rise	GPM (L/h)	20.8 (4724)	41.6 (9449)	62.4 (14174)	83.2 (18898)	104 (23621)	125 (28347)	145.6 (33072)	166.4 (37797)
30°F rise	GPM (L/h)	17.3 (3937)	35 (7874)	52 (11811)	69.3 (15749)	87 (19684)	104 (23623)	121.3 (27560)	138.7 (31497)
35°F rise	GPM (L/h)	15 (3374)	30 (6749)	44.6 (10124)	59.4 (13499)	74.3 (16872)	89 (20248)	104 (23623)	119 (26997)
40°F rise	GPM (L/h)	13 (2953)	26 (5906)	39 (8859)	52 (11811)	65 (14763)	78 (17717)	91 (20670)	104 (23623)

Heating Circuit / Boiler Pumps

Viessmann offers a variety of Grundfos heating circuit/boiler pumps which meet typical Vitodens system installation requirements (see “Heating circuit pump (field supplied)” or “Boiler pump (field supplied)” in the Installation Examples starting on page 35). See tables below for recommended pumps. Refer to the graphs on page 10 and 11 for the proper waterside boiler friction loss calculations. The following pumps have been selected based on boiler heat exchanger head loss and boiler piping to a low-loss header.

Before using the following pumps for a DHW tank application, find out the proper pressure drop through the tank, the required temperature difference through the coil and system piping head loss of the domestic hot water.

IMPORTANT

Pump selection must be based on accurate system flow and pressure drop calculations (includes DHW sizing).

Model		B2HA 19	B2HA 28	B2HA 35
Flow rate				
20°F Δt	GPM (L/h)	6.1 (1385)	--	--
25°F Δt	GPM (L/h)	4.9 (1113)	--	--
30°F Δt	GPM (L/h)	4.0 (909)	6.1 (1381)	--
35°F Δt	GPM (L/h)	3.5 (795)	5.2 (1184)	6.5 (1476)
40°F Δt	GPM (L/h)	3.1 (704)	4.6(1035)	5.7 (1295)
Flow limitation	GPM (L/h)	4.4 (1200)	6.2 (1400)	6.2 (1400)
Recommended boiler pumps		Grundfos UPS 15-58 (3-speed), Taco 0015, Wilo Star S 21 FX		

Model B2HA 45	Flow rate GPM (L/h)	Boiler pressure drop ft. (m)	Recommended pump option 1 Grundfos	Recommended pump option 2 Grundfos
20°F Δt	14.6 (3316)	15.8 (4.8)	UPS 26-99FC, 115V, Speed3	--
25°F Δt	11.7 (2653)	10.0 (3.1)	UPS 26-99FC, 115V, Speed2	UP 26-64F, 115V
30°F Δt	9.7 (2211)	7.5 (2.3)	UPS 26-99FC, 115V, Speed2	--
35°F Δt	8.3 (1805)	5.8 (1.8)	UPS 26-99FC, 115V, Speed1	--
40°F Δt	7.3 (1658)	4.2 (1.3)	UPS 26-99FC, 115V, Speed1	--
Flow limitation	15.4 GPM (3500 L/h)			

Model B2HA 60	Flow rate GPM (L/h)	Boiler pressure drop ft. (m)	Recommended pump option 1 Grundfos	Recommended pump option 2 Grundfos
20°F Δt	--	--	--	--
25°F Δt	15.4 (3500)	16.7 (5.1)	UPS 26-99FC, 115V, Speed3	--
30°F Δt	12.9 (2937)	12.6 (3.8)	UPS 26-99FC, 115V, Speed3	UP 26-64F, 115V
35°F Δt	11.1 (2518)	9.2 (2.8)	UPS 26-99FC, 115V, Speed2	UP 26-64F, 115V
40°F Δt	9.7 (2203)	7.5 (2.3)	UPS 26-99FC, 115V, Speed2	--
Flow limitation	15.4 GPM (3500 L/h)			

Model B2HA 80, 285	Flow rate GPM (L/h)	Boiler pressure drop ft. (m)	Recommended pump Grundfos
20°F Δt	--	--	--
25°F Δt	20.8 (4724)	9.2 (2.8)	UPS 26-99FC, 115V, Speed3
30°F Δt	17.3 (3937)	6.5 (2.0)	UPS 26-99FC, 115V, Speed2
35°F Δt	15 (3374)	4.8 (1.5)	UPS 26-99FC, 115V, Speed2
40°F Δt	13 (2953)	3.4 (1.0)	UPS 26-99FC, 115V, Speed2
Flow limitation	25 GPM (5700 L/h)		

Low-Loss Header Application

Sizing of Low-Loss Header in a Residential Single-Boiler Application

Boiler Model	No. of Boilers	Boiler Max. Flow Rate GPM (L/h)	Typical System Flow Rates							Viessmann Low-loss Temp. Sensor Required
			Δt *1	$^{\circ}\text{F}$ ($^{\circ}\text{C}$)	20 (11.0)	25 (14.0)	30 (17.0)	35 (19.5)	40 (22.0)	
B2HA 19	1	6.2 (1400)	System Flow Rate LLH Required LLH Model	GPM (L/h)	6.1 (1385) Optional 80/60	4.9 (1108) Optional 80/60	4.1 (924) Optional 80/60	3.5 (792) Optional 80/60	3.1 (693) Optional 80/60	Included
B2HA 28	1	6.2 (1400)	System Flow Rate LLH Required LLH Model	GPM (L/h)	9.1 (2071) Yes 80/60	7.3 (1657) Yes 80/60	6.1 (1381) Optional 80/60	5.2 (1184) Optional 80/60	4.6 (1035) Optional 80/60	Included
B2HA 35	1	6.2 (1400)	System Flow Rate LLH Required LLH Model	GPM (L/h)	11.4 (2589) Yes 80/60	9.1 (2071) Yes 80/60	7.6 (1726) Yes 80/60	6.5 (1480) Optional 80/60	5.7 (1295) Optional 80/60	Included
B2HA 45	1	15.4 (3500)	System Flow Rate LLH Required LLH Model	GPM (L/h)	14.6 (3316) Yes 80/60	11.7 (2653) Optional 80/60	9.7 (2211) Optional 80/60	8.3 (1895) Optional 80/60	7.3 (1658) Optional 80/60	Included
B2HA 60	1	15.4 (3500)	System Flow Rate LLH Required LLH Model	GPM (L/h)	19.4 (4406) Yes 80/60	15.5 (3525) Yes 80/60	12.9 (2937) Optional 80/60	11.1 (2518) Optional 80/60	9.7 (2203) Optional 80/60	Included
B2HA 80, 285	1	25 (5700)	System Flow Rate LLH Required LLH Model	GPM (L/h)	26 (5905) Yes 120/80	20.8 (4724) Yes 120/80	17.3 (3937) Optional 120/80	15 (3374) Optional 120/80	13 (2953) Optional 120/80	Included

* 1 For system $\Delta t < 20^{\circ}\text{F}$ use low-loss header sizes for $\Delta t 20^{\circ}\text{F}$.

Low-Loss Header Application *(continued)*

Sizing of Low-Loss Header in a Commercial Multiple-Boiler Application

Boiler Model	No. of Boilers	Boiler Max. Flow Rate GPM (L/h)	Total Flow Rate GPM (L/h)	Typical System Flow Rates							Viessmann Low-loss Temp. Sensor Required*2
				Δt *1	$^{\circ}\text{F}$ ($^{\circ}\text{C}$)	20 (11.0)	25 (14.0)	30 (17.0)	35 (19.5)	40 (22.0)	
B2HA 45	2	15.4 (3500)	30.8 (7000)	System Flow Rate LLH Required LLH Model	GPM (L/h)	29.2 (6632) Yes 120/80	23.4 (5306) Yes 120/80	19.5 (4421) Yes 80/60	16.7 (3790) Yes 80/60	14.6 (3316) Yes 80/60	Yes
B2HA 45	3	15.4 (3500)	46.2 (10500)	System Flow Rate LLH Required LLH Model	GPM (L/h)	43.8 (9949) Yes 160/80	35 (7959) Yes 120/80	29.2 (6633) Yes 120/80	25 (5685) Yes 120/80	22 (4974) Yes 120/80	Yes
B2HA 45	4	15.4 (3500)	61.6 (14000)	System Flow Rate LLH Required LLH Model	GPM (L/h)	58.4 (13265) Yes 200/120	46.7 (10612) Yes 200/120	39 (8843) Yes 160/80	33.4 (7580) Yes 120/80	29.2 (6632) Yes 120/80	Yes
B2HA 45	5	15.4 (3500)	77 (17500)	System Flow Rate LLH Required LLH Model	GPM (L/h)	73 (16580) Yes 200/120	58.4 (13264) Yes 200/120	48.7 (11053) Yes 200/120	41.7 (9474) Yes 160/80	36.5 (8290) Yes 160/80	Yes
B2HA 45	6	15.4 (3500)	92.4 (21000)	System Flow Rate LLH Required LLH Model	GPM (L/h)	87.6 (19898) Yes 250/150	70.1 (15918) Yes 200/120	58.4 (13265) Yes 200/120	50.1 (11370) Yes 200/120	43.8 (9949) Yes 160/80	Yes
B2HA 45	7	15.4 (3500)	107.8 (24500)	System Flow Rate LLH Required LLH Model	GPM (L/h)	102.2 (23214) Yes 250/150	81.8 (18571) Yes 250/150	68.1 (15476) Yes 200/120	58.4 (13265) Yes 200/120	51.1 (11607) Yes 200/120	Yes
B2HA 45	8	15.4 (3500)	123.2 (28000)	System Flow Rate LLH Required LLH Model	GPM (L/h)	116.8 (26530) Yes 250/150	93.4 (21224) Yes 250/150	78 (17687) Yes 200/120	66.7 (15160) Yes 200/120	58.4 (13265) Yes 200/120	Yes

Note: for multiple boiler applications when using the Vitodens 200-W, B2HA boilers, refer to the multiple boiler low-loss distribution manifold installation instructions.

*1 For system $\Delta t < 20^{\circ}\text{F}$ use low-loss header sizes for $\Delta t 20^{\circ}\text{F}$.

*2 Low-Loss temperature sensor - standard equipment of the cascade control Vitotronic 300-K: for use in multiple boiler applications.

Low-Loss Header Application *(continued)*

Sizing of Low-Loss Header in a Commercial Multiple-Boiler Application

Boiler Model	No. of Boilers	Boiler Max. Flow Rate	Total Flow Rate	Typical System Flow Rates							Viessmann Low-loss Temp. Sensor Required*2
				Δt *1	$^{\circ}F$ ($^{\circ}C$)	20 (11.0)	25 (14.0)	30 (17.0)	35 (19.5)	40 (22.0)	
B2HA 60	2	15.4 (3500)	30.8 (7000)	System Flow Rate LLH Required LLH Model	GPM (L/h)	38.8 (8813) Yes 160/80	31 (4050) Yes 120/80	26 (5875) Yes 120/80	22.2 (5036) Yes 120/80	19.4 (4406) Yes 80/60	Yes
B2HA 60	3	15.4 (3500)	46.2 (10500)	System Flow Rate LLH Required LLH Model	GPM (L/h)	58.2 (13220) Yes 200/120	46.6 (10576) Yes 200/120	38.8 (8813) Yes 160/80	33.3 (7554) Yes 120/80	29 (6610) Yes 120/80	Yes
B2HA 60	4	15.4 (3500)	61.6 (14000)	System Flow Rate LLH Required LLH Model	GPM (L/h)	77.6 (17626) Yes 200/120	62 (14101) Yes 200/120	51.7 (11750) Yes 200/120	44.3 (10072) Yes 200/120	38.8 (8813) Yes 160/80	Yes
B2HA 60	5	15.4 (3500)	77 (17500)	System Flow Rate LLH Required LLH Model	GPM (L/h)	97 (22031) Yes 250/150	77.6 (17625) Yes 200/120	64.7 (14687) Yes 200/120	55.4 (12589) Yes 200/120	48.5 (11015) Yes 200/120	Yes
B2HA 60	6	15.4 (3500)	92.4 (21000)	System Flow Rate LLH Required LLH Model	GPM (L/h)	116.4 (26439) Yes 250/150	93.1 (21151) Yes 250/150	77.6 (17626) Yes 200/120	66.5 (15108) Yes 200/120	58.2 (13220) Yes 200/120	Yes
B2HA 60	7	15.4 (3500)	107.8 (24500)	System Flow Rate LLH Required LLH Model	GPM (L/h)	135.8 (30846) Yes 300/200	108.6 (24677) Yes 250/150	90.5 (20564) Yes 250/150	77.6 (17626) Yes 200/120	68 (15423) Yes 200/120	Yes
B2HA 60	8	15.4 (3500)	123.2 (28000)	System Flow Rate LLH Required LLH Model	GPM (L/h)	155.2 (35252) Yes 300/200	124.2 (28202) Yes 300/200	103.5 (23502) Yes 250/150	88.7 (20144) Yes 250/150	77.6 (17626) Yes 200/120	Yes

Note: for multiple boiler applications when using the Vitodens 200-W, B2HA boilers, refer to the multiple boiler low-loss distribution manifold installation instructions.

*1 For system $\Delta t < 20^{\circ}F$ use low-loss header sizes for $\Delta t 20^{\circ}F$.

*2 Low-Loss temperature sensor - standard equipment of the cascade control Vitotronic 300-K: for use in multiple boiler applications.

Low-Loss Header Application *(continued)*

Sizing of Low-Loss Header in a Commercial Multiple-Boiler Application

Boiler Model	No. of Boilers	Boiler Max. Flow Rate	Total Flow Rate	Typical System Flow Rates							Viessmann Low-loss Temp. Sensor Required*2
				Δt *1	$^{\circ}F$ ($^{\circ}C$)	20 (11.0)	25 (14.0)	30 (17.0)	35 (19.5)	40 (22.0)	
B2HA 80, 285	2	25 (5700)	50 (11400)	System Flow Rate LLH Required LLH Model	GPM (L/h)	52.0 (11811) Yes 200/120	41.6 (9449) Yes 200/120	35 (7874) Yes 120/80	30 (6749) Yes 120/80	26 (5906) Yes 120/80	Yes
B2HA 80, 285	3	25 (5700)	75 (17100)	System Flow Rate LLH Required LLH Model	GPM (L/h)	78 (17717) Yes 200/120	62.4 (14174) Yes 200/120	52 (11811) Yes 200/120	44.6 (10124) Yes 200/120	39 (8859) Yes 160/80	Yes
B2HA 80, 285	4	25 (5700)	100 (22800)	System Flow Rate LLH Required LLH Model	GPM (L/h)	104 (23223) Yes 250/150	83.2 (18898) Yes 250/150	69.3 (15749) Yes 200/120	59.4 (13499) Yes 200/120	52 (11811) Yes 200/120	Yes
B2HA 80, 285	5	25 (5700)	125 (28500)	System Flow Rate LLH Required LLH Model	GPM (L/h)	130 (29526) Yes 300/200	104 (23621) Yes 250/150	87 (19684) Yes 250/150	74.3 (16872) Yes 200/120	65 (14763) Yes 200/120	Yes
B2HA 80, 285	6	25 (5700)	150 (34200)	System Flow Rate LLH Required LLH Model	GPM (L/h)	156 (35434) Yes 300/200	125 (28347) Yes 300/200	104 (23623) Yes 250/150	89 (20248) Yes 250/150	78 (17717) Yes 200/120	Yes
B2HA 80, 285	7	25 (5700)	175 (39900)	System Flow Rate LLH Required LLH Model	GPM (L/h)	182 (41340) Yes 300/200	145.6 (33072) Yes 300/200	121.3 (27560) Yes 300/200	104 (23623) Yes 250/150	91 (20670) Yes 250/150	Yes
B2HA 80, 285	8	25 (5700)	200 (45600)	System Flow Rate LLH Required LLH Model	GPM (L/h)	208 (47246) Yes 400/200	166.4 (37797) Yes 300/200	138.7 (31497) Yes 300/200	119 (26997) Yes 250/150	104 (23623) Yes 250/150	Yes

Note: for multiple boiler applications when using the Vitodens 200-W, B2HA boilers, refer to the multiple boiler low-loss distribution manifold installation instructions.

*1 For system $\Delta t < 20^{\circ}F$ use low-loss header sizes for $\Delta t 20^{\circ}F$.

*2 Low-Loss temperature sensor - standard equipment of the cascade control Vitotronic 300-K: for use in multiple boiler applications.

Domestic Hot Water Production

Vitodens 200-W boilers can be used in conjunction with the stand-alone DHW storage tanks offered by Viessmann.

Size and select the DHW storage tank based on the forecasted DHW consumption of the building in question. For further technical information on DHW storage tanks, see the Vitocell Technical Data Manuals.

For the connection of a stand-alone DHW tank, installation fittings (field supplied), an external circulating pump for DHW production (field supplied) and a DHW temperature sensor (optional equipment, see Viessmann Price List for order information) are required.

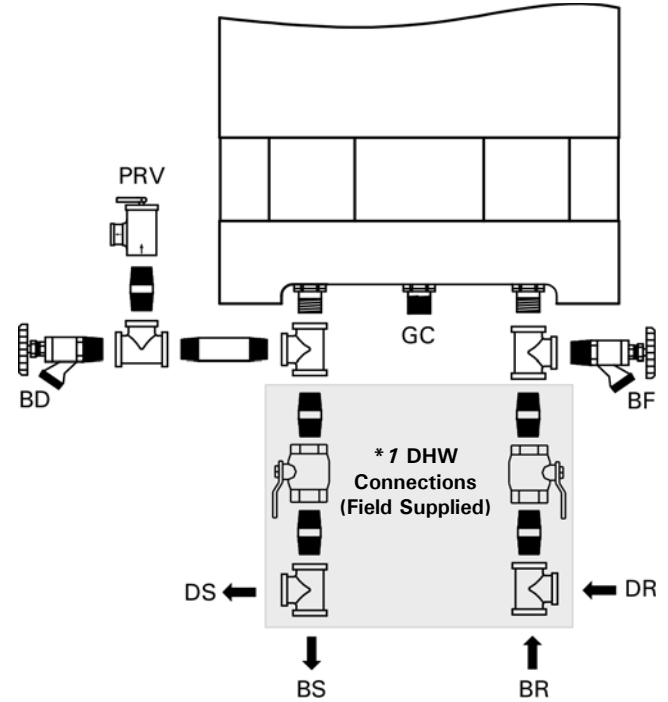
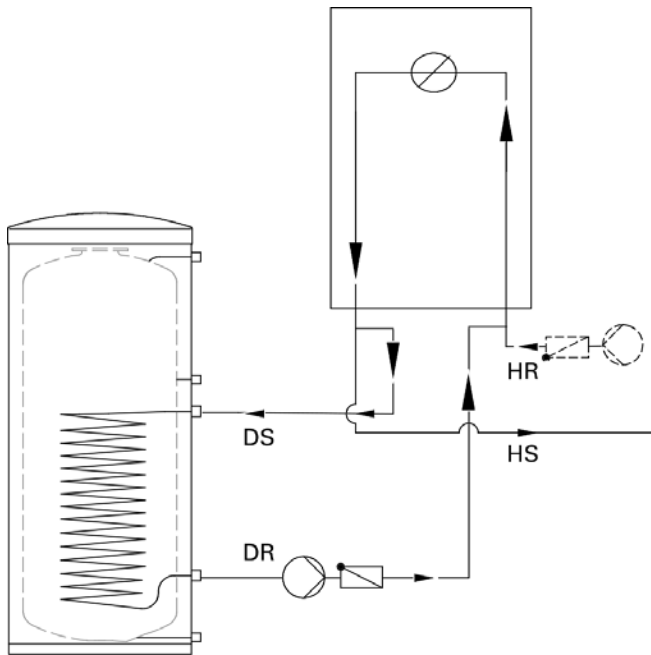

Legend

- DR Boiler heating return for domestic hot water production
- DS Boiler heating supply for domestic hot water production
- HR Heating Return
- HS Heating Supply
- BD Boiler Drain
- BR Boiler Return
- BS Boiler Supply
- GC Gas Connection
- PRV Pressure Relief Valve
- BF Boiler Fill
- PG Pressure Gage (not shown)
- *1 See page 45 for alternate DHW connection.

IMPORTANT

An adequately sized pre-charged expansion tank must be used. See Installation Examples for details.

Domestic Hot Water Recirculation

Vitocell stand-alone DHW storage tank

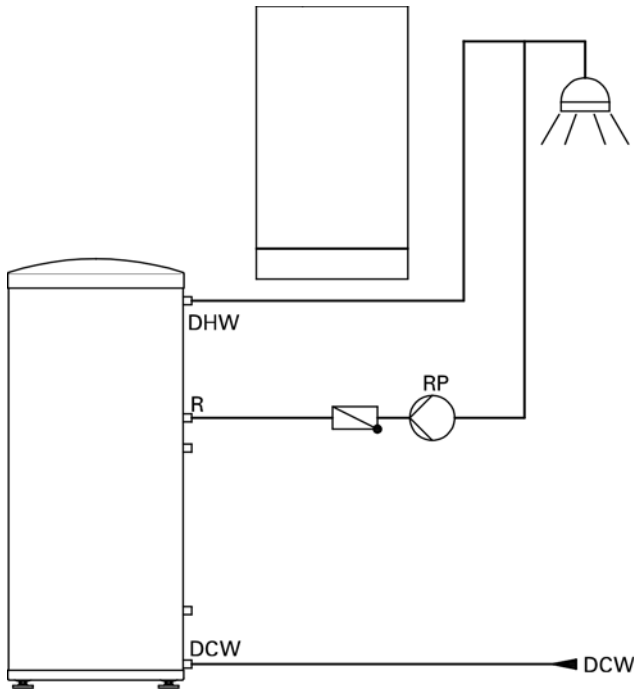

DHW recirculation lines increase the level of comfort and convenience of the domestic hot water supply and reduce water consumption.

These advantages directly derive from the immediate availability of domestic hot water at all draw points.

Poor insulation of the DHW recirculation line, however, can result in considerable heat loss. Viessmann therefore recommends that effective insulation be provided and used for DHW recirculation lines of 23 ft. (7 m) in length or longer.

Legend

DCW	Domestic Cold Water
DHW	Domestic Hot Water
TPV	Temperature and Pressure Relief Valve (on tank - not shown)
R	DHW Recirculation Line
RP	DHW Recirculation Pump

Mounting Bracket

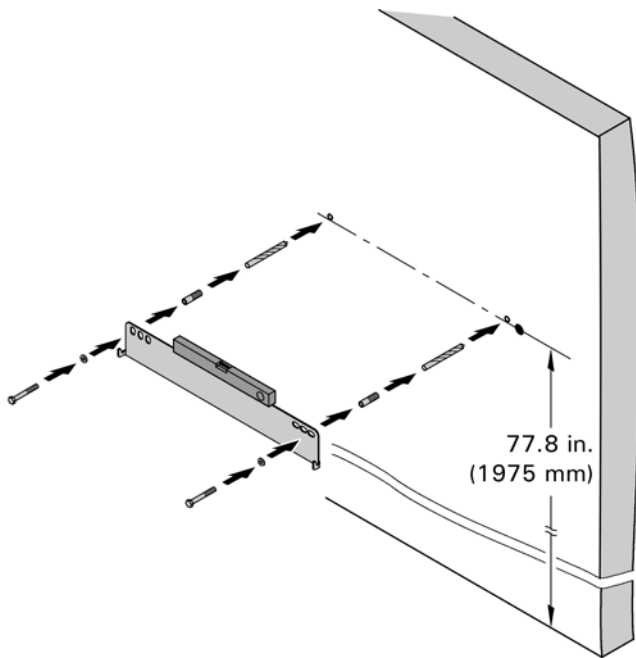

Fitting the wall mounting bracket

See the installation instructions applicable to the mounting bracket on each type of material.

! CAUTION

Whichever mounting method is used, ensure that the bracket is tightly and securely fastened to wall. Failure to secure boiler properly could cause boiler to loosen, posing a severe safety hazard.

Models B2HA 19, 28, 35

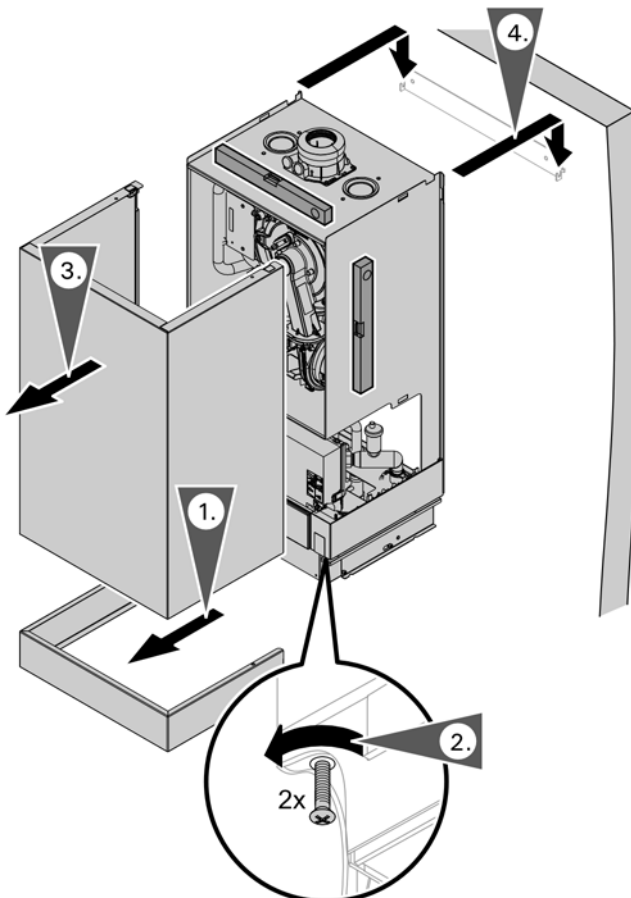

1. Remove the external accessories connection box cover.
2. Loosen the screws at the bottom of the boiler (do not remove completely).
3. Remove the front enclosure panel (lift up and pull away from the boiler).
4. Mount boiler onto the mounting bracket and connect boiler to the installation fittings.
5. Ensure the boiler is securely mounted.

! CAUTION

The boiler must be level both vertically and horizontally to ensure proper draining of the condensate.

Models B2HA 45, 60

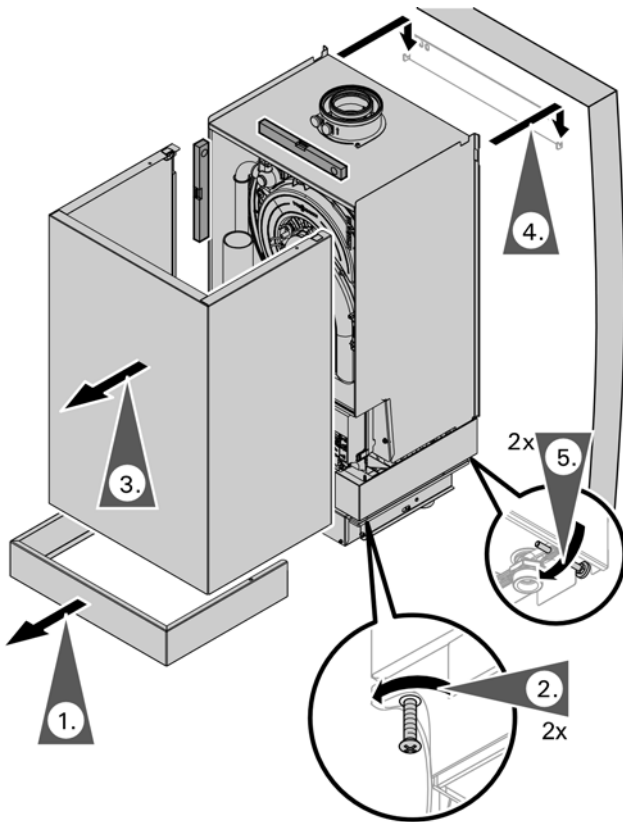

1. Remove the external accessories connection box cover.
2. Loosen the screws at the bottom of the boiler (do not remove completely).
3. Remove the front encloser panel (lift up and pull away from the boiler).
4. Mount boiler onto the mounting bracket and ensure the boiler is securely mounted.
5. Adjust the levelling screws to ensure the boiler is level. Place the round bubble level on top of the boiler to verify.
6. Connect the boiler to the installation fittings.

CAUTION

The boiler must be level both vertically and horizontally to ensure proper draining of the condensate.

Models B2HA 80, 285

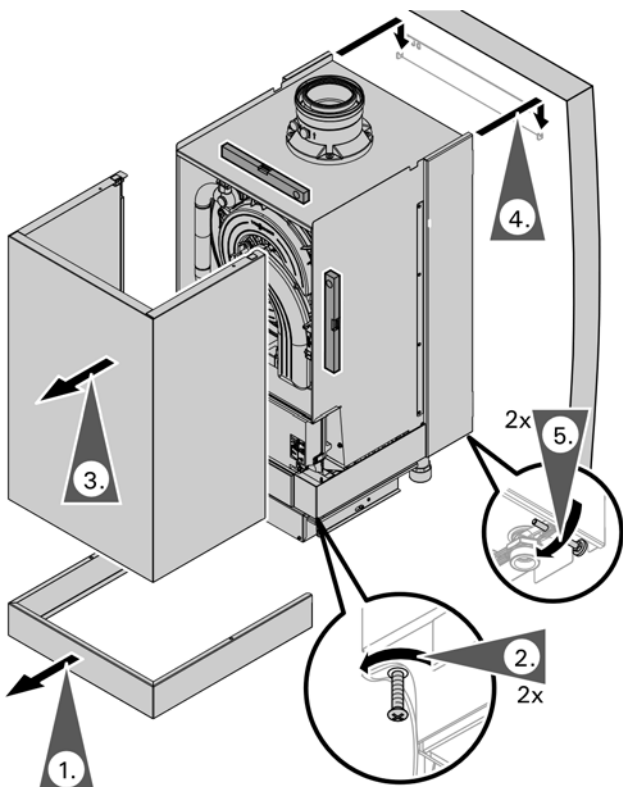

1. Remove the external accessories connection box cover.
2. Loosen the screws at the bottom of the boiler (do not remove completely).
3. Remove the front encloser panel (lift up and pull away from the boiler).
4. Mount boiler onto the mounting bracket and ensure the boiler is securely mounted. Connect boiler to the installation fittings.
5. Adjust the levelling screws to ensure the boiler is level. Place the round bubble level on top of the boiler to verify.

CAUTION

The boiler must be level both vertically and horizontally to ensure proper draining of the condensate.

Boiler Stand for B2HA 19 to 285

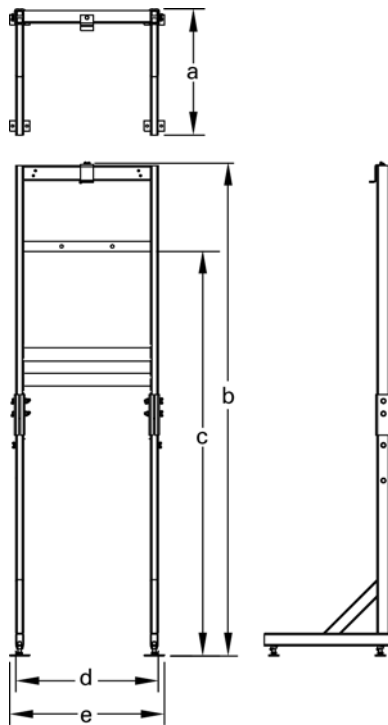

The boiler stand is used for free-standing installation of a single boiler within the mechanical room.

When using the boiler stand, ensure that the stand is securely fastened to the floor (recommended concrete expansion anchors are Hilti model KB-TZ 3/8 x 4 or equivalent).

a	in. (mm)	19 ⁵ / ₈ (500)
b	in. (mm)	76 ³ / ₄ ± 1/2 (1950 ± 12.7)
c	in. (mm)	63 ± 1/2 (1600 ± 12.7)
d	in. (mm)	22 (560)
e	in. (mm)	24 (610)

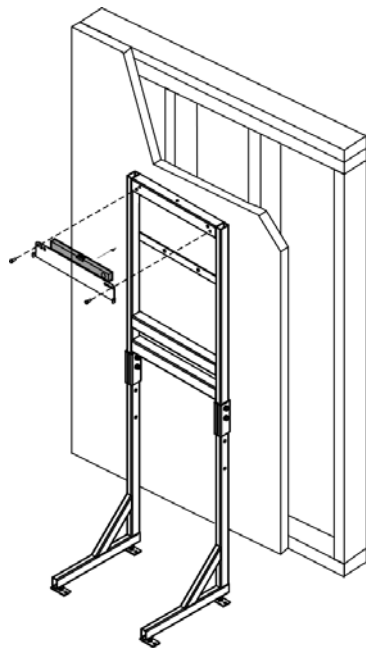

The Vitodens 200-W, model B2HA does not come with a mounting template. The wall location for the frame, mounting bracket and all vents must be field calculated.

Boiler mounting bracket and frame

1. Attach the wall mounting bracket (supplied with the boiler) to the boiler mounting frame using the supplied hardware. Ensure that the wall mounting bracket is level.
2. Move the rack into position and secure to the floor (and to the wall if needed).

Models B2HA 19, 28, 35

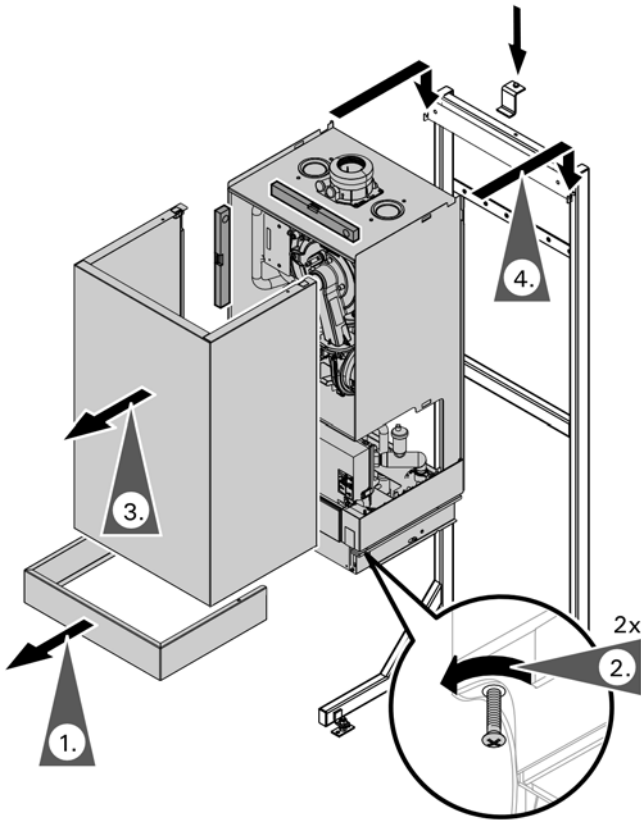

1. Remove the external accessories connection box cover.
2. Loosen the screws at the bottom of the boiler (do not remove completely).
3. Remove the front encloser panel (lift up and pull away from the boiler).
4. Mount boiler onto the mounting bracket and ensure the boiler is securely mounted. Then install the holding bracket to the frame on top of the boiler.
5. Connect the boiler to the installation fittings.

CAUTION

The boiler must be level both vertically and horizontally to ensure proper draining of the condensate.

Models B2HA 45, 60

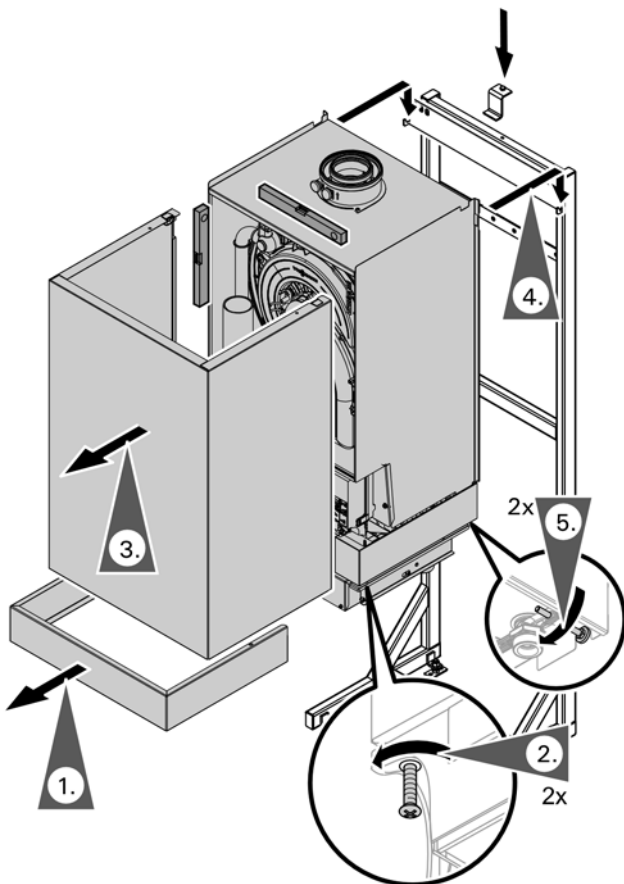

1. Remove the external accessories connection box cover.
2. Loosen the screws at the bottom of the boiler (do not remove completely).
3. Remove the front encloser panel (lift up and pull away from the boiler).
4. Mount boiler onto the mounting bracket and ensure the boiler is securely mounted. Then install the holding bracket to the frame on top of the boiler.
5. Adjust the levelling screws to ensure the boiler is level.
6. Connect the boiler to the installation fittings.

CAUTION

The boiler must be level both vertically and horizontally to ensure proper draining of the condensate.

Model B2HA 80, 285

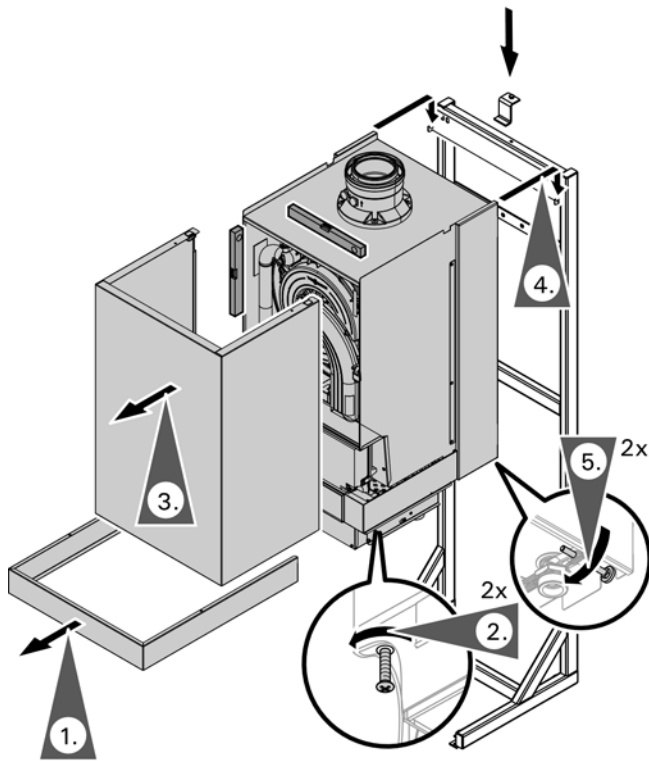

1. Remove the external accessories connection box cover.
2. Loosen the screws at the bottom of the boiler (do not remove completely).
3. Remove the front encloser panel (lift up and pull away from the boiler).
4. Mount boiler onto the mounting bracket and ensure the boiler is securely mounted. Then install the holding bracket to the frame on top of the boiler.
5. Adjust the levelling screws to ensure the boiler is level.
6. Connect the boiler to the installation fittings.

CAUTION

The boiler must be level both vertically and horizontally to ensure proper draining of the condensate.

Condensate Connection

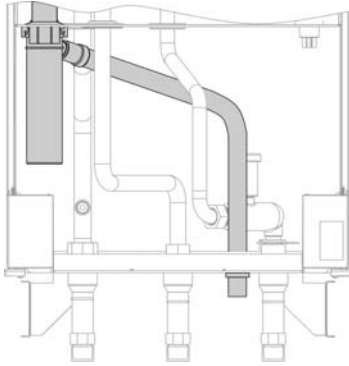

Condensate Connection for Vitodens 200-W, models B2HA 19, 28, 35

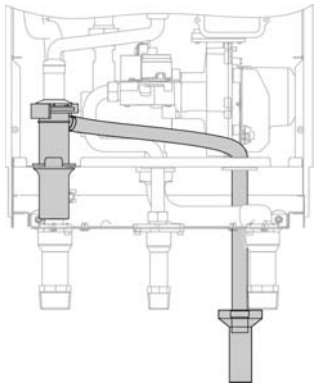

Condensate Connection for Vitodens 200-W, models B2HA 45, 60

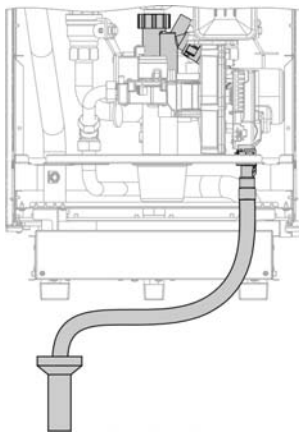

Condensate Connection for Vitodens 200-W, models B2HA 80, 285

Install the condensate drain pipe with a suitable gradient. Discharge condensate from the boiler into the drainage system, either directly or (if required) via a neutralization unit (accessory).

IMPORTANT

Pipe ventilation must take place between the siphon trap and the neutralization unit (if applicable).

Condensate Drainage and Neutralization

The condensate formed both in the condensing boiler and in the flue gas pipe must be discharged into the public sewage system in accordance with all applicable local regulations. The condensate produced by a gas-fired heating system has a pH value between 3 and 4.

Some local codes may require the use of a separate neutralization unit to treat the aggressive and corrosive nature of the condensate. With a neutralization unit installed, all condensate from the boiler and the flue gas pipe enters into the neutralization unit where it is treated and released into the public sewage system with a safe pH value of above 6.5.

The use of neutralization granulate (performing the neutralizing process) is dependent on the operation of the heating system. To determine the required refill amount, check granulate level several times during the first year of operation. In some cases one granulate fill may last an entire year.

Contact Viessmann to order a neutralization unit for the Vitodens 200-W boiler.

See Viessmann Price List for order information.

The condensate discharge outlet to the drainage system connection must be clearly visible. It must be installed with a suitable gradient and provided with a stretch trap.

If the condensate outlet of the Vitodens 200-W boiler is lower than the drain, a condensate pump must be used.

Only corrosion-resistant materials must be used for condensate drainage purposes (e.g. braided hose). Do not use galvanized materials or materials containing copper for piping, couplings etc. The condensate drain must have a trap to prevent flue gas leakage.

Please note that other requirements might apply depending on local regulations and/or project-specific details.

It is advisable to contact your local waterworks office (authority responsible for waste water regulations) well before commencing with the installation of the neutralization unit in order to establish details of local regulations that apply.

The following table shows the concentration of (effluent) substances (e.g. heavy metals) contained in the waste water from the Vitodens 200-W condensing boiler.

Condensate (effluent) substances	Values measured in mg/L Vitodens 200-W
Lead	< 0.01
Cadmium	< 0.005
Chromium	< 0.01
Copper	< 0.01
Nickel	< 0.01
Zinc	< 0.05
Tin	< 0.05

Venting Options

For detailed information refer to the Installation Instructions for the Vitodens 200-W, B2HA Venting System.

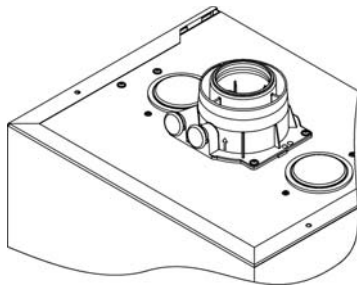

Vent Connection, (with optional air intake openings on sides) for models B2HA 19, 28, 35

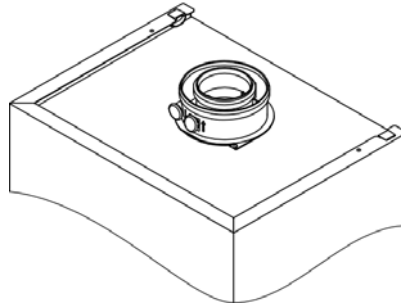

Vent Connection, for models B2HA 45, 60

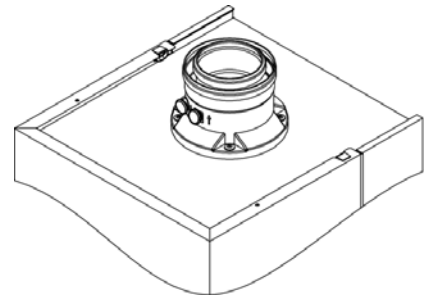

Vent Connection, for models B2HA 80, 285

Electrical Connections

Power Supply

The Vitodens 200-W requires a standard 120 VAC power outlet 15A fuse protected circuit. Refer to the installation instructions shipped with the boiler for wiring details, or reference the "Overview of Electrical Connections" on pages 46 and 48 of this manual.

Power Supply Connection of Accessories

The power supply connection of accessories can be made directly at the boiler control. The connection is activated and deactivated with the system on/off switch. The mixing valve accessory kit and the Vitosolic control (if used) will require a separate 120 VAC power supply from the wall receptacle.

Wire cabling required for:

- Outdoor temperature sensor
- Vitotronic 200-H, HK1B mixing valve control
- Accessory kit for heating circuit with mixing valve
- Vitotrol 200A remote control
- Vitotrol 300A remote control
- Remote switching of operating mode
- Remote disable
- Alarm output

On-Board Vitotronic 200, HO1B Control

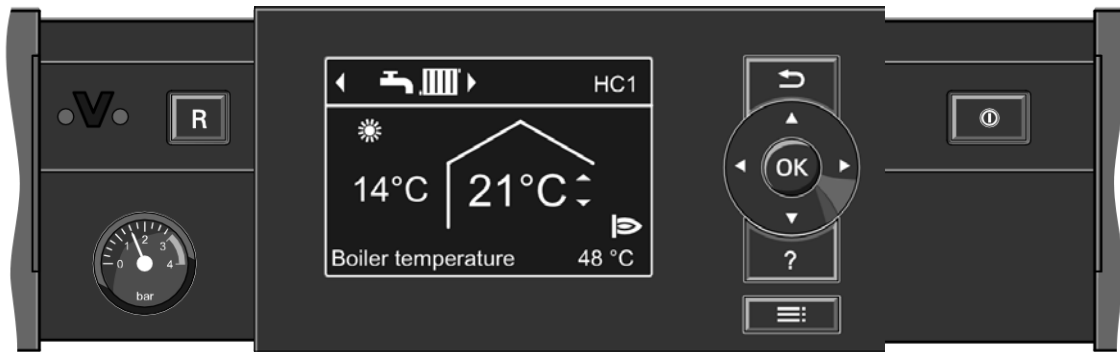

Modular structure

The control unit is integrated into the boiler. The control unit comprises a standard unit, electronics modules and a programming unit.

Standard unit:

- ON/OFF switch
- Optolink laptop interface
- Operating and fault indicators
- Reset button
- Fuses

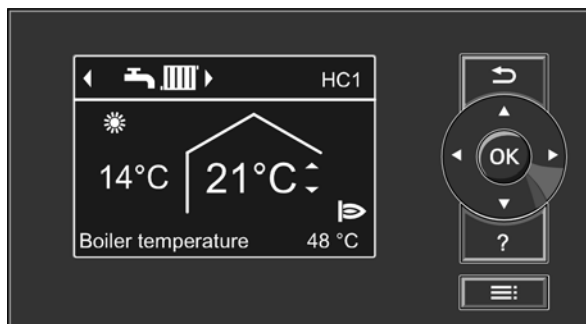

Programming unit:

- Easy operation through:
 - Plain text display with graphic ability
 - Large font and black & white depiction for good contrast
 - Context-sensitive help text
 - Removable programming unit; can be mounted on the wall with separate accessory
- With digital time switch
- Control keys for:
 - Navigation
 - Confirmation
 - Help and additional information
 - Menu
- Setting the:
 - Room temperature
 - Reduced room temperature
 - DHW temperature
 - Heating program
 - Time programs for central heating, DHW heating and DHW circulation
 - Economy mode
 - Party mode
 - Holiday program
 - Heating curves
 - Codes
 - Actuator tests
 - Test mode
- Displaying the:
 - Boiler water temperature
 - DHW temperature
 - Operating details
 - Diagnostic details
 - Fault messages

Design and Function

Functions

- Weather-compensated control of the boiler water and/or flow temperature
- Control of one heating circuit without mixer and two heating circuits with mixer
- Control of one heating circuit without mixer and two heating circuits with mixer
- Demand-dependent heating circuit pump and burner off control
- Adjustment of a variable heating limit
- Anti-seizing pump protection
- Integral diagnostic system
- Maintenance display
- DHW temperature control with priority
- Control of solar DHW heating and central heating backup in conjunction with the solar control module, type SM1
- Display of the solar energy yield
- Auxiliary function for DHW heating (short-term heating to a higher temperature)
- 0-10V External signal input

Control Characteristics

PI characteristics with modulating output.

Time Switch

Digital time switch.

- Individual and 7-day program
- Automatic daylight savings time changeover
- Automatic function for DHW heating and DHW recirculation pump
- Time, day and standard switching times for space heating, DHW heating and the DHW circulation pump are factory-set
- Switching times are individually programmable, i.e. up to four switching periods per day
Shortest switching interval: 10 minutes
Power backup: 14 days.

Setting the Operating Programs

The heating system frost protection (see frost protection function) applies to all heating programs. You can select the following heating programs with the program keys:

- Heating and DHW
- DHW only
- Standby mode

External heating program changeover.

Frost protection

- The frost protection function will be started when the outside temperature drops below approx. 34°F (1°C). With the frost protection function, the heating circuit pump will be switched ON and the boiler water is maintained at a lower temperature of approx. 68°F (20°C). The DHW tank will be heated to approx. 68°F (20°C).
- The frost protection function will be stopped when the outside temperature rises above approx. 37°F (3°C) (default settings).

Summer Operation

Heating program “”

The burner is only activated upon a call for domestic hot water from the DHW storage tank (controlled by DHW tank temperature sensor).

Design and Functions *(continued)*

Technical Data

Rated supply voltage:	120VAC
Rated frequency:	60 Hz
Rated current:	12 A
Max. ambient temp. - at operation:	32 to 104°F (0 to 40°C) Installation in living spaces or boiler rooms (standard ambient conditions)
- when storing or transporting:	-4 to +158°F (-20 to +70°C)
Max. operating temp. setting (space heating):	
Models B2HA 19-60	165°F (74°C)
Models B2HA 80, 285	185°F (85°C)
DHW production:	
Models B2HA 19-60	165°F (74°C)
Models B2HA 80, 285	185°F (85°C)
Setting fixed high limit: (not adjustable)	210°F (99°C)
Adjustment range of DHW tank set-point temperature:	50 to 154°F (10 to 68°C)

Heating curve settings

- Heating curve slope:	0.2 to 3.5
- Heating curve shift:	-12 to +33°C -13 to 40 K

Heating Curve Adjustment (slope and shift)

The control unit regulates the boiler water temperature (= supply temperature of heating circuit without mixing valve) and the supply temperature of the heating circuit with mixing valve (in conjunction with the accessory kit for a heating circuit with mixing valve) according to the outdoor temperature. The boiler water temperature is automatically raised by 0 to 72 F / 0 to 40 K higher than the currently required set supply temperature (in the factory default setting the differential temperature is 14.4 F / 8 K). See Service Instructions for coding address "9F" in coding level 2.

The supply temperature that is required to achieve a given room temperature depends on the heating system and the thermal insulation of the building that is being heated.

The adjustment of the two heating curves is used to match the boiler water temperature and the supply temperature to these conditions. The boiler water temperature is limited upwards by the fixed high limit and the temperature set for the electronic high limit. The supply temperature cannot rise above the boiler water temperature.

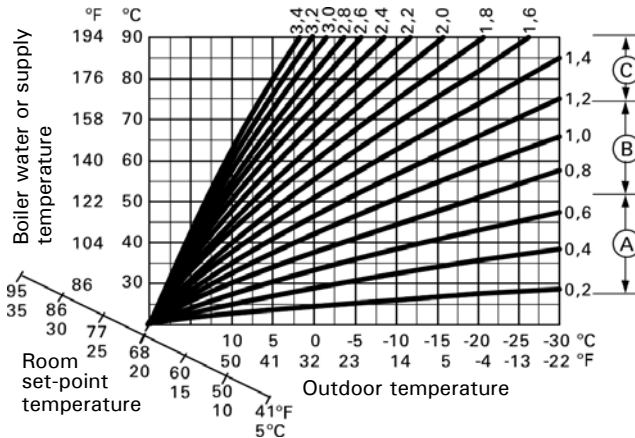

Legend

- (A) Low temperature heating system, e.g. radiant floor heating
- (B) Medium temperature heating system, e.g. cast iron radiation, staple-up radiant floor heating
- (C) High temperature heating system, e.g. fintube radiation, fan coils

Design and Functions *(continued)*

Boiler Temperature Sensor

The boiler temperature sensor is connected at the control unit for weather-responsive operation and is built into the boiler.

Specification sensor type: Viessmann NTC 10K ohms at 77°F (25°C)

Max. ambient temp.

- at operation: 32 to 266°F (0 to 130°C)
- when storing or transporting: - 4 to + 158°F (-20 to + 70°C)

DHW Tank Temperature Sensor

(immersion temperature sensor)

Supplied with:

- Cable length approx. 13 ft. (3.75 m), ready to plug in
- All pipe connections are field supplied.

Specification

Max. ambient temp.

- at operation: 32 to 194°F (0 to 90°C)
- when storing or transporting: - 4 to + 158°F (-20 to + 70°C)
- Sensor type: Viessmann NTC 10K ohms @ 77°F (25°C)

Immersion Temperature Sensor

To capture the low loss temperature

Specification

Lead length fully wired: 12 ft. (3.75 m),

Permissible ambient temp.

- during operation: 32 to 194°F (0 to 90°C)
- when storing or transporting: - 4 to + 158°F (-20 to + 70°C)

Outdoor Temperature Sensor

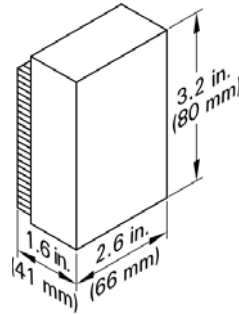

Sensor location:

- North or northwest wall of building
- 6.6 to 8.2 ft. (2 to 2.5 m) above ground or in case of a multi-storey building approximately halfway up the second floor

Electrical connection:

- 2-wire cable, max. cable length 115 ft. (35 m) with a wire size of min. AWG 16 copper
- Cable to the outdoor sensor must not be laid near line voltage wiring (120/240 V)

Max. ambient temperature

during transport, storage and operation: -40 to 194°F (-40 to 90°C)

Vitotronic Control Accessories

Supply Temperature Sensor

(strap-on sensor, included with mixing valve actuator accessory kit),

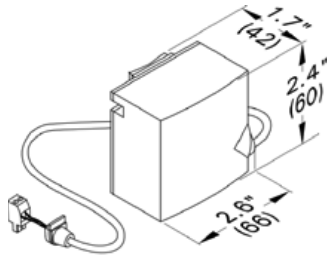

- when storing or transporting: -4 to +158°F (-20 to +70°C)

Installed with a strapping band.

Cable length 19.7 ft. (6 m), ready to plug in.

Max. ambient temp.

- at operation: 32 to 212°F (0 to 100°C)
- when storing or transporting: -4 to +149°F (-20 to +70°C)

Room Temperature Sensor,

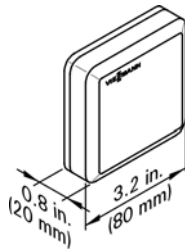

Separate room temperature sensor as supplement to the Vitotrol 200A and 300A; to be used if the Vitotrol 200A or 300A cannot be installed inside the main living room or in a suitable position where the unit can capture and adjust the temperature.

Installation in the main living room on an internal wall opposite radiators. Never install inside shelf units, recesses, immediately by a door or heat source (e.g. direct sunlight, fireplace, TV set, etc.).

Connect the room temperature sensor to the Vitotrol 200A or 300A.

Electrical connection:

- 2-wire cable with a wire size of min. AWG 18 copper
- The cable length between the control unit, remote control unit and room temperature sensor must not exceed 98 ft. (30 m)

Max. ambient temp.

- at operation: 32 to 104°F (0 to 40°C)
- when storing or transporting: -4 to +149°F (-20 to +65°C)

Mixing Valve Actuator Kit

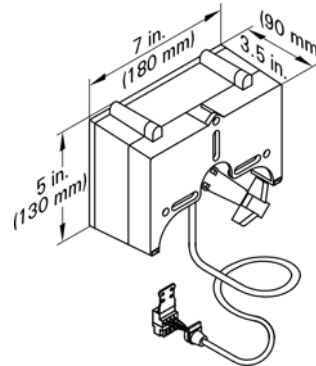

The mixing valve actuator is mounted directly on the Viessmann ¼ to 2½" mixing valve.

The mixing valve actuator is a motor-driven control unit.

The rotational direction is reversible.

The mixing valve actuator comes with a plug-in connector for a heating circuit pump, supply temperature sensor (strap-on sensor with 7 ft. (2.1 m) connecting cable), power supply connecting cable 9 ft. (2.7 m) and a connecting cable 9 ft. (2.7 m) for the KM-BUS Expansion Module.

Rated voltage: 120 VAC

Rated frequency: 60 Hz

Rated current: 4 A

Power consumption: 5W max. ambient temperature
- at operation: 32°F to 104°F (0°C to 40°C)

application in living areas and installation sites (normal ambient conditions)

-storage & shipping: -4°F to 149°F (-20°C to 65°C)

Max. relay outputs at 120 VAC for:

- Heating circuit pump 1.0 A
- Mixing valve 0.2 A

Vitotronic Control Accessories *(continued)*

Mixing Valve Extension Module

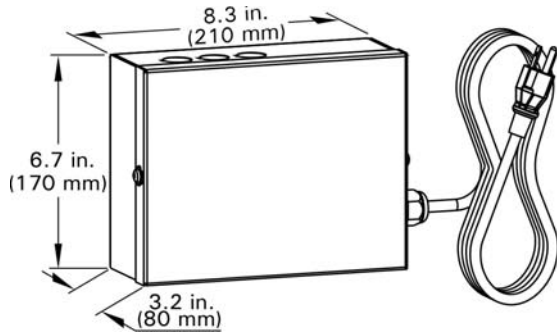

Rated voltage: 120 VAC
 Rated frequency: 60 Hz
 Rated current: 4 (2) A
 Power consumption: 4 W
 Max. ambient temp.
 - at operation: 32 to 104°F (0 to 40°C)
 - when storing or transporting: -4 to +149°F (-20 to +65°C)
 Relay output for heating circuit pump: 4 (2) A, 120 VAC
 Actuator torque: 3 Nm
 Time of 90°: 2 minutes

KM BUS Expansion Module

To connect 2 to 9 devices (mixing valve actuator, Vitotrol, input module, etc.) to the single KM BUS connection of the boiler.

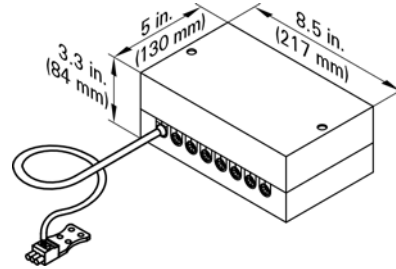

Specification
 Lead length 10 ft. (3.0 m), fully wired
 Permissible ambient temp.
 - during operation 32 to 104°F (0 to 40°C)
 - during storage and transport: -4 to +149°F (-20 to +65°C)

LON Communication Module

Electronic PCB for data exchange with the Vitotronic 200-H, Vitocom 200 and for connecting to a higher level building management system.

LON Connecting Cable

(for data exchange between control units)
 Cable length 23 ft. (7 m), fully wired

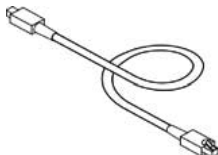

LON Terminal End Resistor

To terminate the LON BUS at the first and the last control unit.

Vitotronic Control Accessories *(continued)*

Vitotrol 200A

One Vitotrol 200A can be used for every heating circuit in a heating system. The Vitotrol 200A can regulate one heating circuit and up to two remote controls may be connected to the control unit.

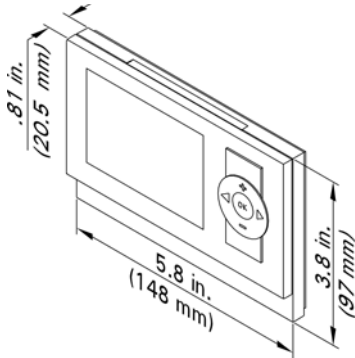

KM BUS Participant

The Vitotrol 200A remote control regulates the required set room temperature in standard mode, from any room in the house.

- Party and economy mode can be enabled via keys
- Only for heating circuit with mixing valve
- Fitted room temperature sensor for room temperature hook-up

WS function:

Installation anywhere in the building.

RS function:

Note: Never activate the RS function for underfloor heating circuits (inertia). In heating systems with a heating circuit without mixing valve and heating circuits with mixing valve, the RS function must only affect the heating circuit with mixing valve.

Room temperature hook-up:

Installation in the main living room on an internal wall opposite radiators. Never install inside shelf units, recesses, immediately by a door or heat source (e.g. direct sunlight, fireplace, TV set, etc.).

The integral room temperature sensor captures the actual room temperature and effects any necessary corrections of the supply temperature as well as a rapid heat-up at the start of the heating operation (if appropriately programmed).

Connection:

- 2-core lead, length max. 50 m (even if connecting several remote control units)
- Never route this lead immediately next to 120/208/460 V cables
- LV plug as standard delivery must be installed in the main living room (lead room).

Specification:

Power supply via KM BUS

Power consumption: 0.2 W

Max. ambient temp.

- at operation: 32 to 104°F (0 to 40°C)
- when storing or transporting: -4 to + 149°F (-20 to + 65°C)

Set room temp. range 37 to 99°F (3 to 37°C)

The set room temperature for reduced mode is adjusted at the control unit.

Vitotronic Control Accessories *(continued)*

Vitotrol 300A

One Vitotrol 300A can be used for every heating circuit in a heating system. The Vitotrol 300A can regulate up to three heating circuits. Up to two remote controls may be connected to the control unit.

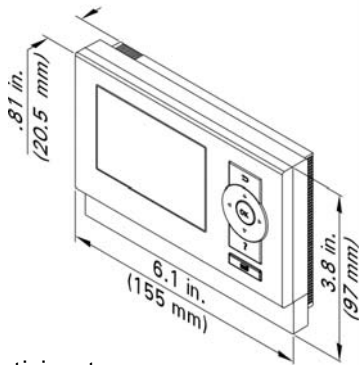

KM BUS Participant

The Vitotrol 300A remote control regulates the required set room temperature for one heating circuit in standard and reduced mode, the heating program and the switching times for central heating, DHW heating and the DHW circulation pump.

Displaying:

- Room temperature
- Outside temperature
- Heating program
- Operating condition
- Solar yield as graphic display

Settings:

- Set room temperatures for standard mode (day temperature) and reduced mode (night temperature) via the standard display
- Heating program, switching times for heating circuits, DHW heating and DHW circulation pump plus further settings via plain text menu on the display
- Party and economy mode can be enabled via the menu
- Only for heating circuit with mixer:
Fitted room temperature sensor for room temperature hook-up

Note: For room temperature hook-up, the Vitotrol 300A must be installed in the main living room (lead room).

RS function:

Installation in the main living room on an internal wall opposite radiators. Never install inside shelving units, in recesses, or immediately by a door or heat source (e.g. direct sunlight, fireplace, TV set, etc.). The fitted room temperature sensor captures the actual room temperature and effects any necessary correction of the flow temperature.

WS function:

Installation anywhere in the building.

Connection:

- 2-core lead, length max. 164 ft. (50 m) (even if connecting several remote control units)
- Never route this lead immediately next to 120/208/460 V cables
- LV plug as standard delivery must be installed in the main living room (lead room).

Specification:

Power supply via KM BUS

Power consumption: 0.2 W

Max. ambient temp.

- at operation: 32 to 104°F (0 to 40°C)
- when storing or transporting: -4 to + 149°F (-20 to + 65°C)

Set room temp. range 37 to 99°F (3 to 37°C)

The set room temperature for reduced mode is adjusted at the control unit.

Accessories for Vitodens 200-W

LON Communication Module

Electronic PCB for data exchange with the Vitotronic 200-H, Vitocom 200 and for connecting to a higher level building management system.

Neutralization Unit for Single-Boiler Applications with neutralizing granulate

for models B2HA 19, 28, 35

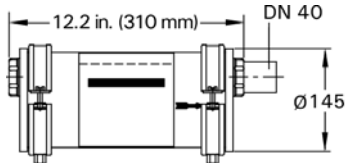

for models B2HA 45, 60

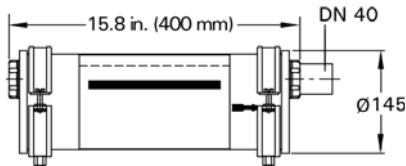

for models B2HA 80, 285

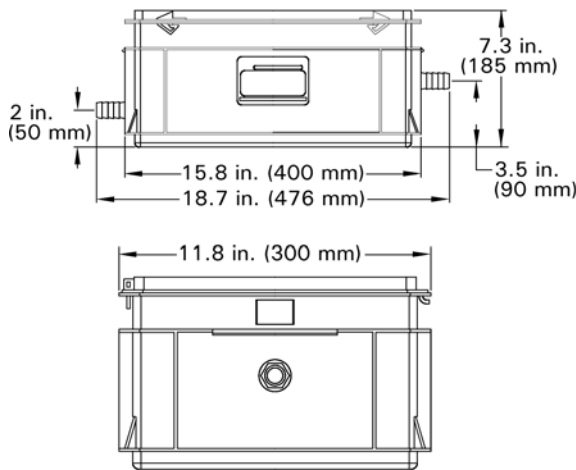

Neutralization Pellets

for models B2HA 19, 28, 35, 45, 60
2 x 1.3 kg for refill or replacement purposes

for models B2HA 80, 285
8 kg for refill or replacement purposes

Fuel Conversion Label Kit (NG > LPG)

(included in boiler technical literature set)

The Vitodens 200-W, B2HA boiler comes factory set for operation with natural gas. All B2HA models can be field converted to operate with liquid propane gas (as well as back to natural gas as required). The kit includes instructions and labels for field conversion.

Low-Loss Header



When used in conjunction with the Vitodens 200-W boiler, the low-loss header acts as hydraulic break, decoupling boiler and system circuits from each other. It is recommended to use the low-loss header in applications in which the total system flow rate exceeds the maximum (or minimum) boiler flow rate. For maximum boiler flow rates, starting on page 10 of this manual.

Viessmann strongly recommends the use of a low-loss header in cases where the system head and flow rates are unknown.

The temperature sensor connection [TS] typically located at the top of the low-loss header ensures low return temperatures to the Vitodens 200-W boiler at all times, increasing operational efficiency. In addition, the low-loss header helps eliminate air and debris [D] from the heating system. See illustrations for design and principle of operation.

The low-loss header is available in the following sizes. Select the size based on the maximum system flow rate of your application.

Accessories for Vitodens 200-W

Low-Loss Header (continued)

Low-loss header design (Type 80/60 or 120/80)

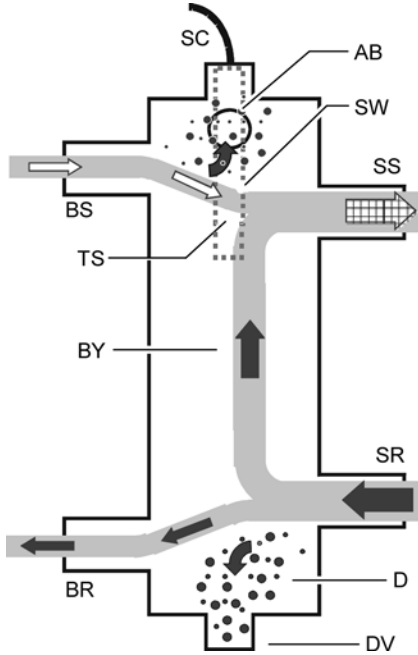

Principle of Operation

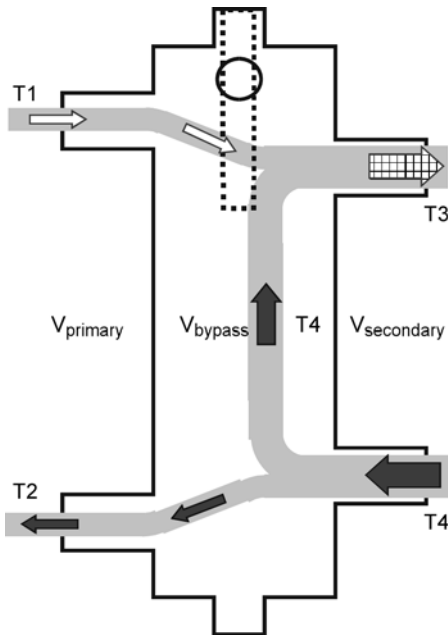

IMPORTANT

Use only a Viessmann supplied temperature sensor.
Do not use any other manufacturer's temperature sensor.

Legend

- AB Air Bleed
- BR Boiler Return
- BS Boiler Supply
- BY Bypass (with laminar flow)
- D Debris and/or air
- DV Drain Valve
- SC Sensor Cable
- SR System Return
- SS System Supply
- TS Viessmann Temperature Sensor
- SW Sensor Well

IMPORTANT

When installing a low-loss header, the system mixed supply temperature (T3) must be calculated as follows:

$$T3 = \frac{T1 \times V_{primary} + T4 \times V_{bypass}}{V_{secondary}}$$

Legend

- T1 Boiler supply temperature
- T2 Boiler return temperature
- T3 System supply temperature
- T4 System return temperature
- Vprimary Boiler circuit flow rate
- Vsecondary Heating circuit flow rate
- Vbypass Bypass flow rate
- Qprimary Heat supplied by boiler
- Qsecondary Heat consumed by system

$$V_{primary} < V_{secondary}$$

$$T1 > T3$$

$$T2 = T4$$

$$Q_{primary} = Q_{secondary}$$

$$T1 \ 167^{\circ}\text{F} \ (75^{\circ}\text{C})$$

$$V_{secondary} = V_{primary} + V_{bypass}$$

Model No.	Max. system flow rate
Type 80/60	19.5 GPM (4.4 m ³ /h)
Type 120/80	35.2 GPM (8 m ³ /h)
Type 160/80 *1	44 GPM (10 m ³ /h)
Type 200/120 *1	80 GPM (18 m ³ /h)

*1 Floor-mounted version (typically used for multiple-boiler installations).

Standard Equipment

The Vitodens 200-W gas-fired condensing boiler with Inox-Radial heat exchanger, modulating MatriX cylinder burner for liquid propane gas and natural gas (available on all models), comes standard with:

- pressure gage
- installation fittings with 30 psig pressure relief valve and air vent (no air vent for model B2HA 80, 285)
- boiler control unit with outdoor temperature sensor, power/pump module
 - The boiler comes prewired and fully piped internally for field connections and prewired.
 - Side wall co-axial vent installations must include Viessmann protective screen!
 - Enclosure finish:
 - black steel, powder-coated white
 - The Vitodens 200-W comes ready for use with natural gas and can be fuel converted to liquid propane gas in the field.
 - Power/Pump module

Wall mounting componentry

The following wall mounting components are supplied with the Vitodens 200-W boiler:

- Mounting bracket
- Mounting bolts
- Installation fittings
- Screws for mounting bracket on
 - wood studs (2" x 4")
 - metal studs
 - brick/concrete wall

Combustion Management System

The combustion management system utilizes the physical correlation between the level of the ionization current and the air factor λ . For all gas qualities, the maximum ionization current results with air factor λ .

The ionization signal is evaluated by the combustion management system, and the air factor is adjusted to between $\lambda = 1.24$ and 1.44 . This range provides for an optimum combustion quality. Thereafter, the electronic gas valve regulates the required gas volume based on the prevailing gas quality.

To check the combustion quality, the CO₂ content or the O₂ content of the flue gas is measured. The actual values enable the prevailing air factor to be determined.

The relationship between the CO₂ or O₂ content and air factor λ is illustrated in the table below.

Air factor λ - CO₂/O₂ content

Air factor λ	O ₂ content (%)	CO ₂ content (%) for natural gas	CO ₂ content (%) for liquid propane gas
1.20	3.8	9.6	11.3
1.24	4.4	9.2	10.9
1.27	4.9	9.0	10.6
1.30	5.3	8.7	10.3
1.34	5.7	8.5	10.0
1.37	6.1	8.3	9.8
1.40	6.5	8.1	9.6
1.44	6.9	7.8	9.3
1.48	7.3	7.6	9.0

The Vitodens 200-W, B2HA boilers come equipped with Lambda Pro, the industry's first intelligent combustion management system. The boiler adjusts automatically to any gas type and quality without the need for a fuel conversion kit.

To achieve an optimum combustion control, the system regularly performs an automatic self-calibration; also after a power failure (shutdown). For this, the combustion is briefly regulated to max. ionization current (equals air factor $\lambda = 1$). The automatic calibration is performed shortly after the burner starts and lasts approximately 5 seconds. During the calibration, higher than normal CO emissions may occur briefly.

Hydraulic Connection

System design

Viessmann condensing boilers can generally be installed in any pumped hot water heating system (closed system). The circulation pump is an integral part of the appliance. Minimum system pressure 15 psi (1.0 bar). The boiler water temperature is limited to 180°F (82°C). To minimise distribution losses, we recommend that you size the heat distribution system to a max. flow temperature of 158°F (70°C).

For apartments with less than 860 ft² (80 m²) living space or for low energy houses with low heat demand we recommend, due to the immediate capturing of the room-influencing factors, the utilisation of the Vitodens with a constant temperature control unit in conjunction with the Vitotrol 100.

To reduce burner cycling in low energy houses with a correspondingly low heat demand, we recommend the use of a low loss header.

Installation Examples

Please note that in the following piping layout examples all pumps are field supplied.

IMPORTANT

The examples on the following pages depict possible piping layouts of the Vitodens 200-W boiler equipped with Viessmann System Technology. For boiler and tank combinations, please install only feasible combinations listed in the Viessmann Price List.

Please note that the following examples are simplified conceptual drawings only! Piping and necessary componentry must be field verified. A low water cut-off (LWCO) must be installed where required by local codes. Proper installation and functionality in the field is the responsibility of the heating contractor.

IMPORTANT

DHW supply and return piping between boiler DHW connections and the Viessmann DHW tank connections, shall be a minimum of 1" nominal pipe diameter (for models B2HA 19 to 35) or 1 ¼" (for models B2HA 45 to 80, 285) DHW connection outlet sizes provided on the boiler and the DHW tank). This will ensure the residual head of the field supplied pump is fully utilized to overcome the resistance of the DHW heat exchanger coil and to provide sufficient water flow to the boiler heat exchanger.

In non-Viessmann DHW tank applications, perform, in addition to the above, accurate calculations for DHW tank coil pressure drop versus boiler pump (field supplied) residual head to ensure sufficient water flow to the boiler heat exchanger. Failure to heed the above instructions may cause boiler short-cycling and inadequate DHW supply.

WARNING

If a DHW storage tank other than a Viessmann Vitocell 100 or 300 tank is used, the installer must verify proper operation of the Viessmann DHW tank temperature sensor with the original manufacturer of the tank. Viessmann strongly recommends the installation of a temperature tempering valve in the DHW supply line.

System Layout 1

Vitodens 200-W, B2HA with a direct-connected heating circuit

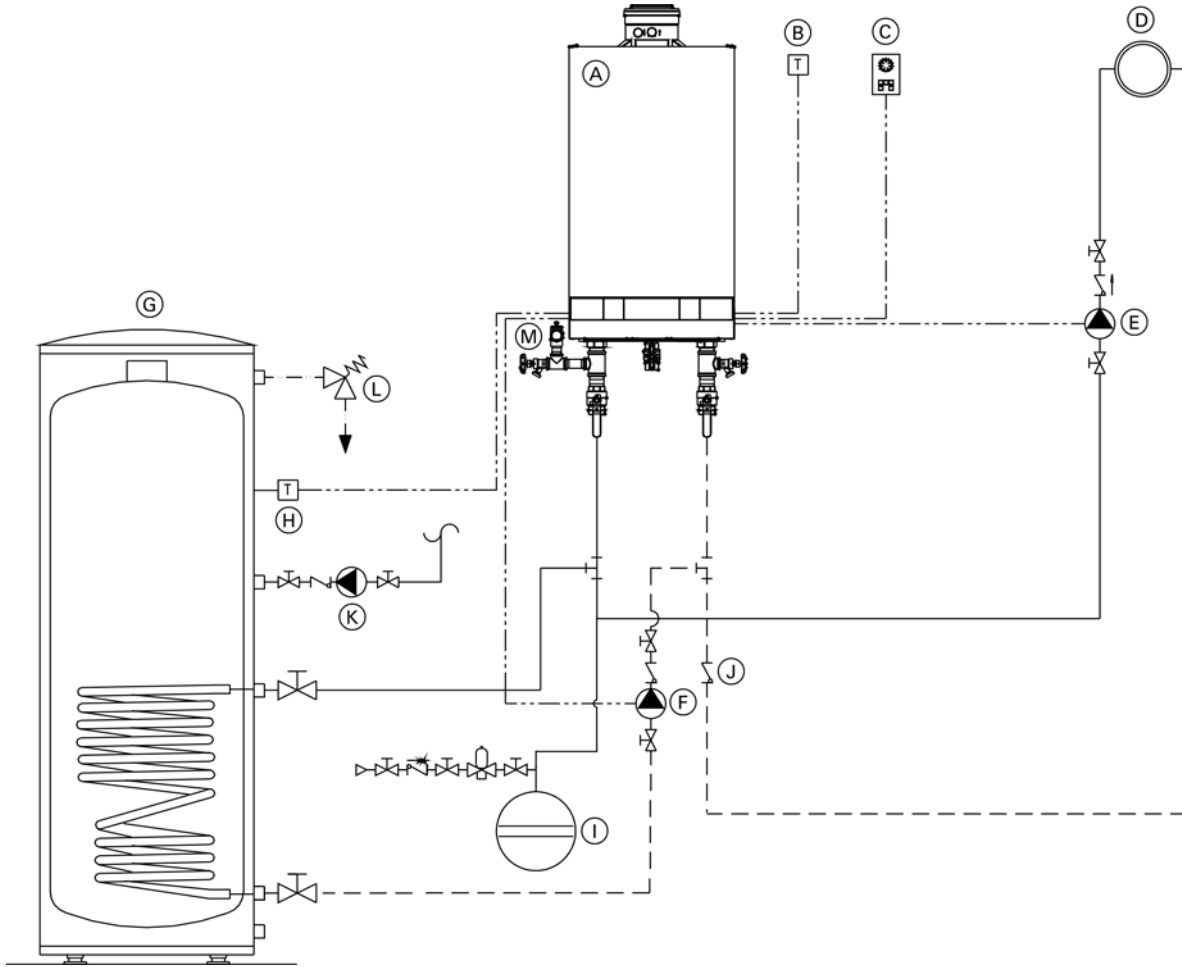

Legend

- (A) Vitodens 200-W B2HA boiler with Vitotronic 200, HO1B outdoor reset control
- (B) Outdoor temperature sensor [1]
- (C) Vitotrol remote (optional)
- (D) Heating circuit
- (E) Heating circuit pump [20]
- (F) DHW circulating pump [21]
- (G) DHW storage tank
- (H) DHW tank temperature sensor [5]
- (I) Expansion tank
- (J) Flow check valve
- (K) DHW recirculation pump [28/20] *
- (L) Temperature and pressure relief valve
- (M) Pressure relief valve

* Function based on coding of address 53

Installation of ...

- radiator heating circuit (high-temp. circuit)
- DHW production

... with the following flow conditions:

The flow rate of the heating circuit is less than the maximum possible water flow rate of the Vitodens 200-W B2HA boiler (see page 10 for maximum water flow rate of boiler).

The use of a low-loss header is strongly recommended if the maximum water flow rate in the application concerned exceeds the values shown in the applicable table on page 11, or if the system flow rates are unknown.

The low-loss header is available as accessory part.

See following pages for installation examples with a low-loss header.

IMPORTANT

DHW circulating pump (F) must pump into the Vitodens 200-W boiler (as illustrated).

System Layout 2

Vitodens 200-W, B2HA with one heating circuit and low-loss header

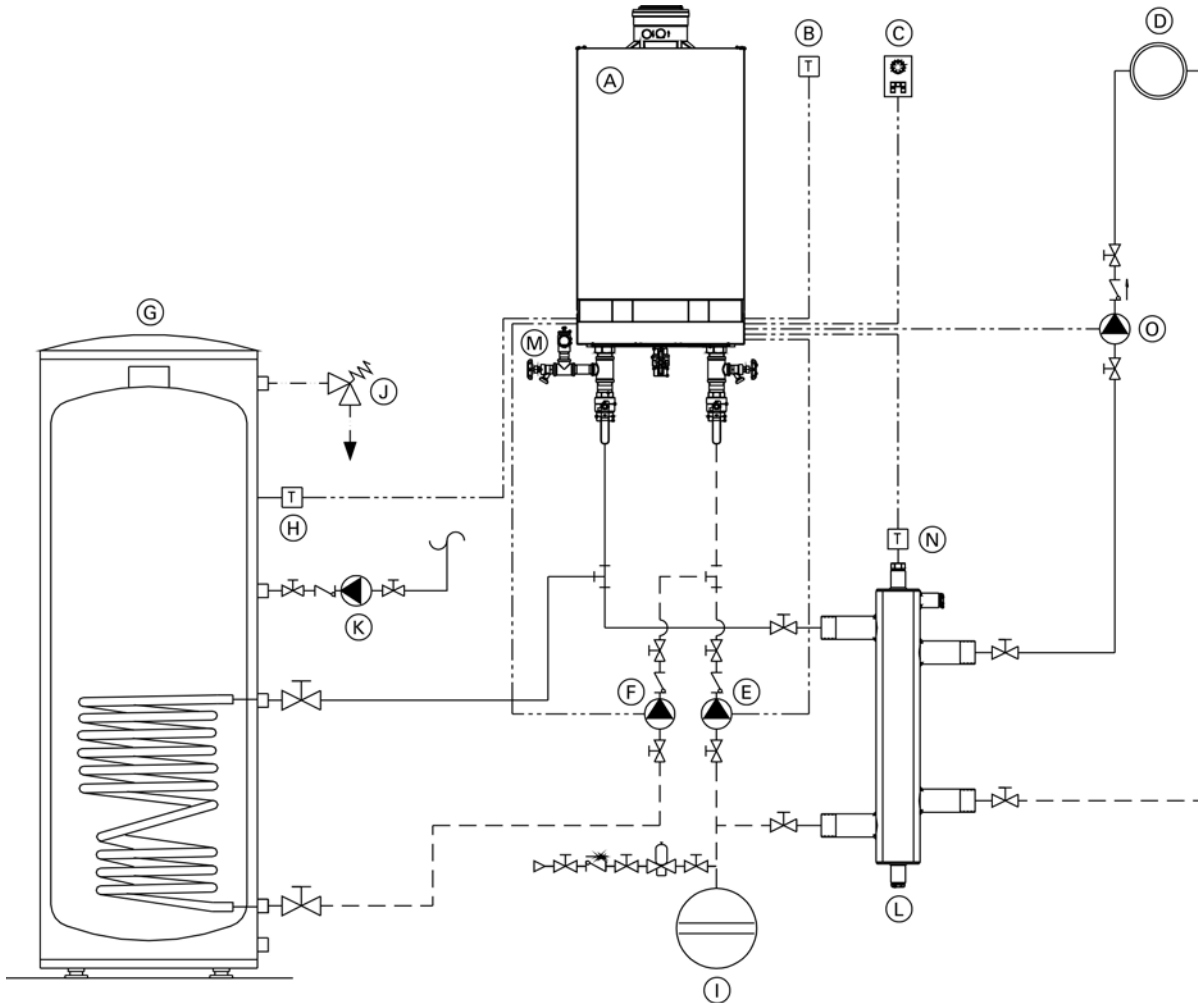

Legend

- (A) Vitodens 200-W B2HA boiler with Vitotronic 200, HO1B outdoor reset control
- (B) Outdoor temperature sensor [1]
- (C) Vitotrol remote (optional)
- (D) Heating circuit
- (E) Boiler pump [20]
- (F) DHW circulating pump [21]
- (G) DHW storage tank
- (H) DHW tank temperature sensor [5]
- (I) Expansion tank
- (J) Temperature and pressure relief valve
- (K) DHW recirculation pump [28/20] *
- (L) Low-loss header
- (M) Pressure relief valve
- (N) Viessmann temperature sensor for low-loss header [2]
- (O) Heating circuit pump [28/20] *

* Function based on coding of address 53

Installation of ...

- radiator heating circuit (high-temp. circuit)
- DHW production

... with the following flow conditions:

The flow rate of the heating circuit is greater than the maximum possible water flow rate of the Vitodens 200-W B2HA boiler (see page 10 for maximum water flow rate of boiler).

The use of a low-loss header is strongly recommended if the maximum water flow rate in the application concerned exceeds the values shown on page 11, or if the system flow rates are unknown.

The low-loss header is available as accessory part.

IMPORTANT

Please note location of expansion tank.

DHW circulating pump (F) must pump into the Vitodens 200-W B2HA boiler (as illustrated).

System Layout 3

Vitodens 200-W, B2HA with...

- DHW storage tank
- one heating circuit with mixing valve and system separation

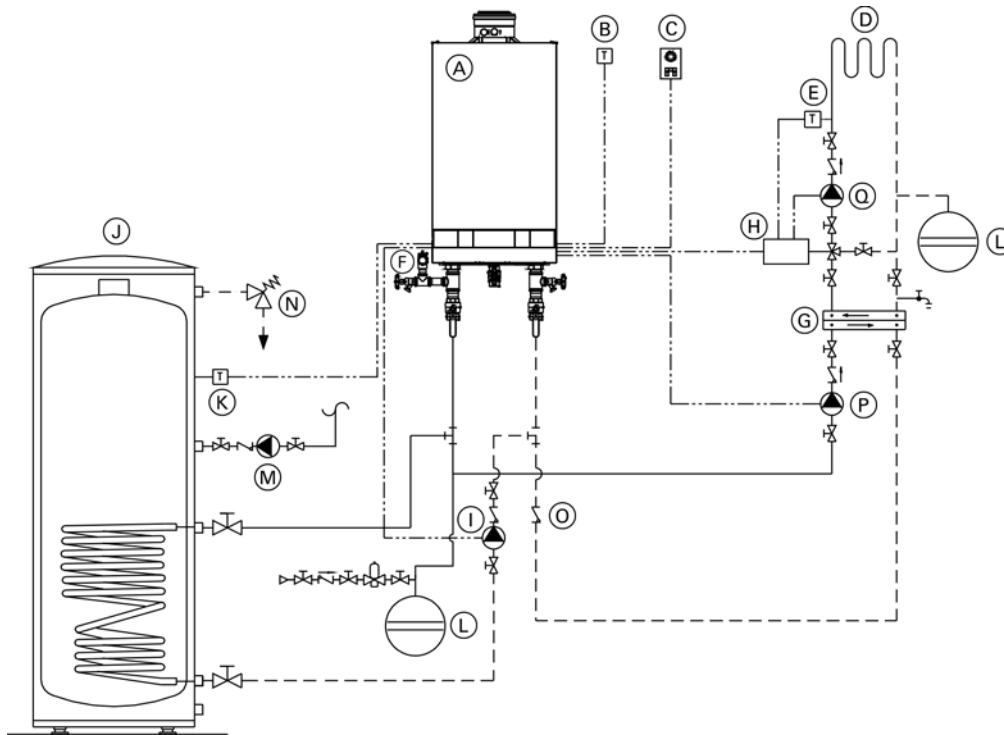

Legend

- (A) Vitodens 200-W B2HA boiler with Vitotronic 200, HO1B outdoor reset control
- (B) Outdoor temperature [1]
- (C) Vitotrol remote (optional)
- (D) Underfloor heating circuit
- (E) Mixing valve temperature sensor [2]
- (F) Pressure relief valve
- (G) Plate heat exchanger for system separation
- (H) Accessory kit for heating circuit with mixing valve
- (I) DHW circulating pump [21]
- (J) DHW storage tank
- (K) DHW tank temperature sensor [5]
- (L) Expansion tank
- (M) DHW recirculation pump [28/20] *
- (N) Temperature and pressure relief valve
- (O) Flow check valve
- (P) Heating circuit pump [20]
- (Q) Heating circuit pump

* Function based on coding of address 53

IMPORTANT

DHW circulating pump must pump (I) into the Vitodens 200-W B2HA boiler (as illustrated).

Installation of ...

- underfloor heating circuit with 3-way mixing valve and system separation (low-temp. circuit)
- DHW production

... with the following flow conditions:

The flow rate of the heating circuit is less than the maximum possible water flow rate of the Vitodens 200-W B2HA boiler.

See page 10 for maximum water flow rate of the Vitodens 200-W B2HA boilers. The use of a low-loss header is recommended if the system water flow rate is unknown. The low-loss header is available as accessory part.

See following pages for installation examples with a low-loss header.

IMPORTANT

System separation is required of underfloor heating systems employing non-oxygen diffusion barrier tubing. All components on the secondary side of the heat exchanger must be made of corrosion-resistant materials.

IMPORTANT

Sizing of field-supplied pump (P) is critical for proper boiler operation in this system layout. See page 10 for the supply head pressure drop of the boiler. An undersized pump may cause short-cycling and/or improper operation of the boiler. Viessmann STRONGLY recommends using a low-loss header and a boiler pump in this system layout.

System Layout 4

Vitodens 200-W, B2HA with...

- DHW storage tank
- one direct-connected heating circuit
- one heating circuit with a mixing valve

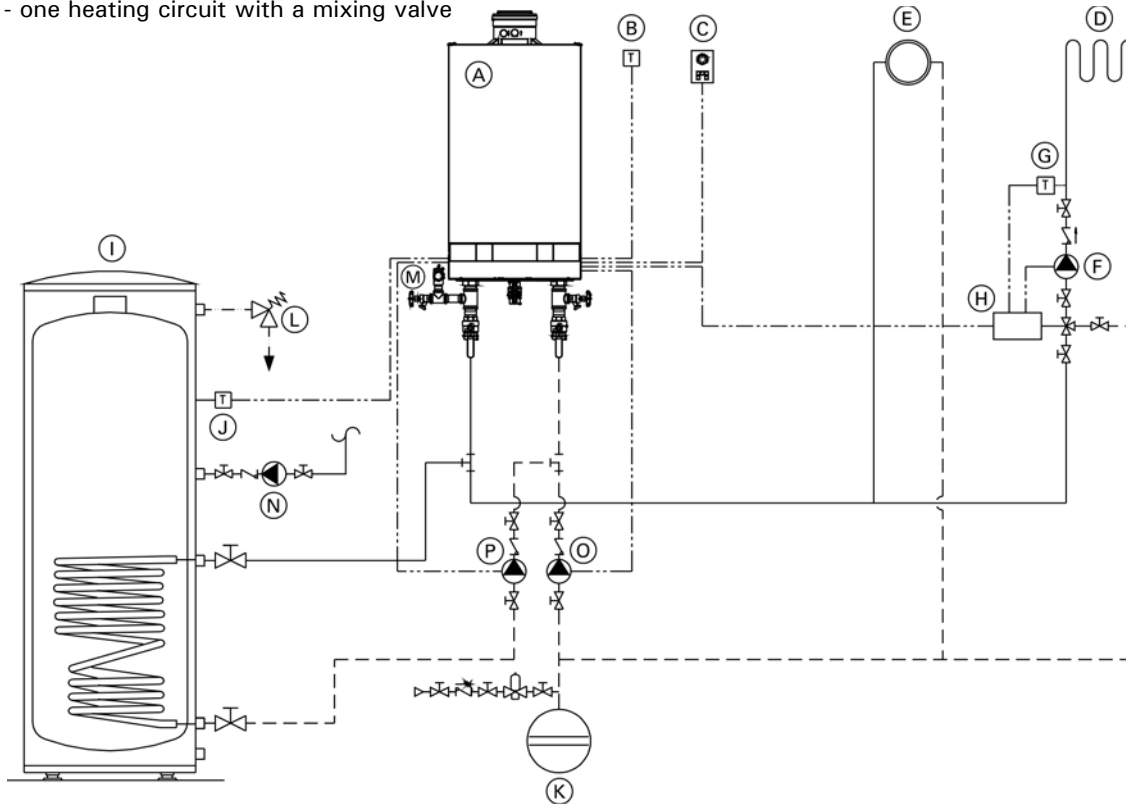

Legend

- (A) Vitodens 200-W B2HA boiler with Vitotronic 200, HO1B outdoor reset control
- (B) Outdoor temperature sensor [1]
- (C) Vitotrol remote (optional)
- (D) Under floor heating circuit
- (E) Radiator heating circuit
- (F) Heating circuit pump
- (G) Mixing valve temperature sensor [2]
- (H) Accessory kit for heating circuit with mixing valve
- (I) Domestic hot water storage tank
- (J) DHW tank temperature sensor [5]
- (K) Expansion tank
- (L) Temperature and pressure relief valve
- (M) Pressure relief valve
- (N) DHW recirculation pump [28/20] *
- (O) Boiler pump [20]
- (P) DHW circulating pump [21]

* Function based on coding of address 53

IMPORTANT

DHW circulating pump (P) must pump into the Vitodens 200-W B2HA boiler (as illustrated).

Installation of ...

- underfloor heating circuit with 3-way mixing valve and system separation (low-temp. circuit)
- DHW production

... with the following flow conditions:

The flow rate of the heating circuit is less than the maximum possible water flow rate of the Vitodens 200-W B2HA boiler.

See page 10 for maximum water flow rate of the Vitodens 200-W B2HA boilers. The use of a low-loss header is recommended if the system water flow rate is unknown. The low-loss header is available as accessory part.

See following pages for installation examples with a low-loss header.

IMPORTANT

System separation is required of underfloor heating systems employing non-oxygen diffusion barrier tubing. All components on the secondary side of the heat exchanger must be made of corrosion-resistant materials.

IMPORTANT

Sizing of field-supplied pump (P) is critical for proper boiler operation in this system layout. See page 10 for the supply head pressure drop of the boiler. An undersized pump may cause short-cycling and/or improper operation of the boiler. Viessmann STRONGLY recommends using a low-loss header and a boiler pump in this system layout.

System Layout 5

Vitodens 200-W, B2HA with...

- DHW storage tank
- one heating circuit with mixing valve
- one heating circuit without mixing valve and low-loss header

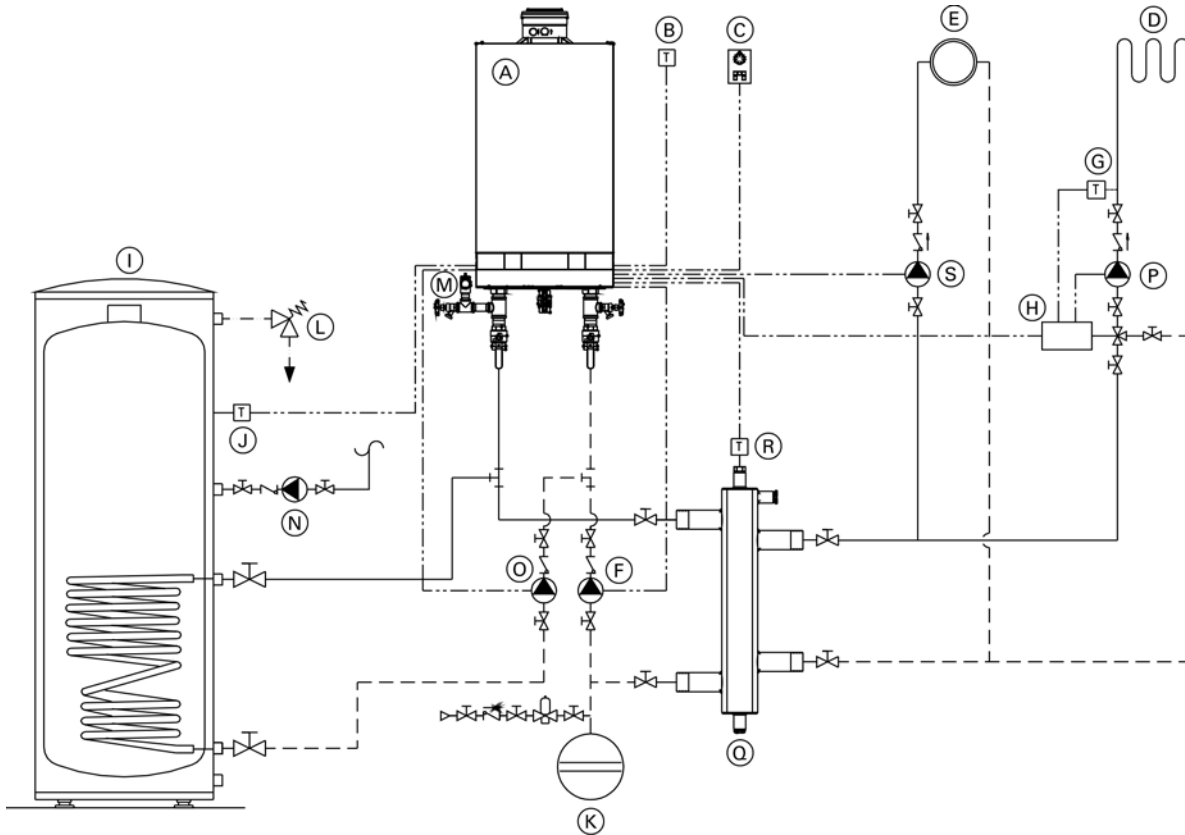

Legend

- (A) Vitodens 200-W B2HA boiler with Vitotronic 200, HO1B outdoor reset control
- (B) Outdoor temperature sensor [1]
- (C) Vitotrol remote (optional)
- (D) Under floor heating circuit
- (E) Radiator heating circuit
- (F) Boiler circuit pump [20]
- (G) Mixing valve temperature sensor [2]
- (H) Kit for heating circuit with mixing valve
- (I) Domestic hot water storage tank
- (J) DHW tank temperature sensor [5]
- (K) Expansion tank
- (L) Temperature and pressure relief valve
- (M) Pressure relief valve
- (N) DHW recirculation pump [28/20] *
- (O) DHW circulating pump [21]
- (P) Heating circuit pump
- (Q) Low-loss header
- (R) Viessmann temperature sensor for low-loss header [2]
- (S) Heating circuit pump [28/20] *

Installation of different heating circuits...

- radiator heating circuit (high-temp. circuit)
- under floor heating circuit with 3-way mixing valve (low-temp. circuit)
- DHW production

... with the following flow conditions:

The total flow rate of the two heating circuits is greater than the maximum possible water flow rate of the Vitodens 200-W B2HA boiler (see page 10 for maximum water flow rate of boiler).

The use of a low-loss header is strongly recommended. The low-loss header is available as accessory part.

The 3-way mixing valve, built-in to achieve the low-temperature level of the under floor heating circuit, is controlled by an accessory kit for a heating circuit with mixing valve.

IMPORTANT

DHW circulating pump (O) must pump into the Vitodens 200-W B2HA boiler (as illustrated).

* Function based on coding of address 53

System Layout 6

Vitodens 200-W, B2HA with...

- DHW storage tank
- one heating circuit without a mixing valve
- two heating circuits with a mixing valve
- low-loss header

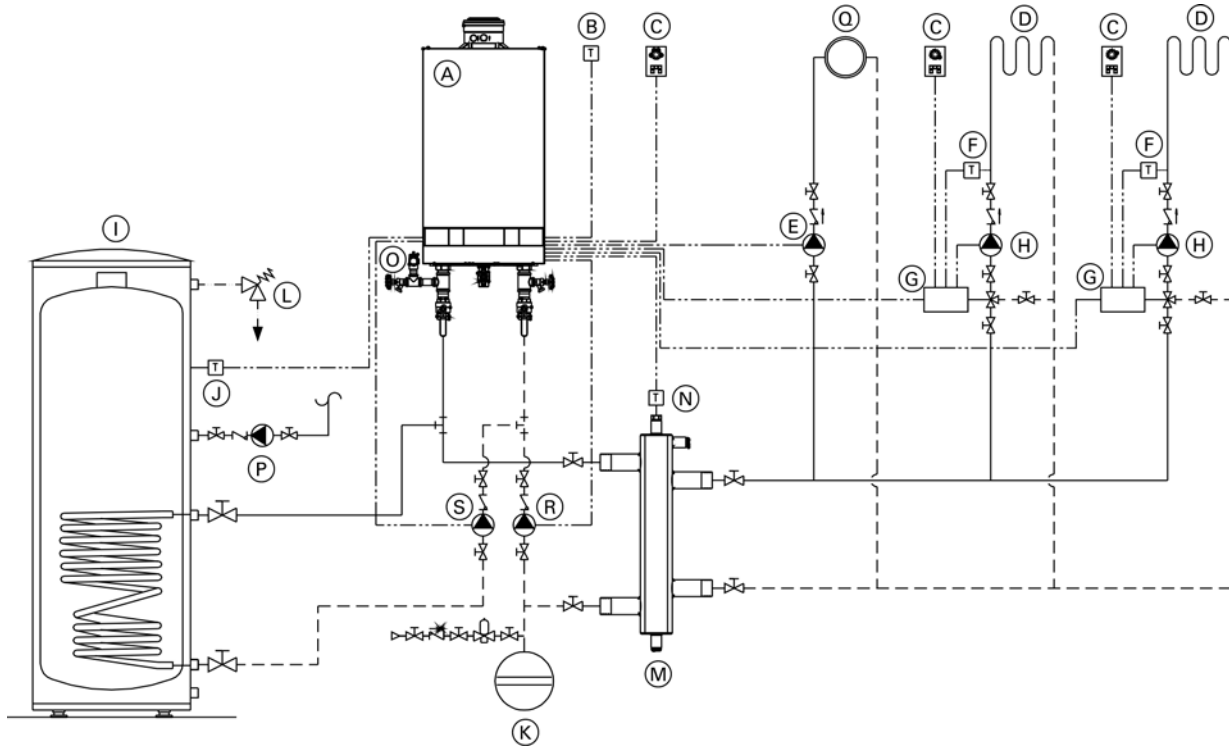

Legend

- (A) Vitodens 200-W B2HA boiler with Vitotronic 200, HO1B outdoor reset control
- (B) Outdoor temperature sensor [1]
- (C) Vitotrol remote (optional)
- (D) Under floor heating circuit
- (E) Heating circuit pump [28/20] *
- (F) Mixing valve temperature sensor [2]
- (G) Accessory kit for heating circuit with mixing valve
- (H) Heating circuit pumps
- (I) DHW storage tank
- (J) DHW tank temperature sensor [5]
- (K) Expansion tank
- (L) Temperature and pressure relief valve
- (M) Low-loss header
- (N) Viessmann temperature sensor for low-loss header [2]
- (O) Pressure relief valve
- (P) DHW recirculation pump [28/20] *
- (Q) Radiator heating circuit
- (R) Boiler pump [20]
- (S) DHW circulating pump [21]

* Function based on coding of address 53

Installation of different heating circuits...

- two heating circuits with 3-way mixing valve (low-temp. circuit)
- DHW production

... with the following flow conditions:

The total flow rate of the two heating circuits is greater than the maximum possible water flow rate of the Vitodens 200-W B2HA boiler (see page 10 for maximum water flow rate of boiler).

The use of a low-loss header is strongly recommended. The low-loss header is available as accessory part.

The 3-way mixing valve, built-in to achieve the low-temperature level of the under floor heating circuit, is controlled by an accessory kit for a heating circuit with a mixing valve.

IMPORTANT

DHW circulating pump (S) must pump into the Vitodens 200-W B2HA boiler (as illustrated).

System Layout 7

Vitodens 200-W, B2HA with...

- direct-connected heating circuit
- one heating circuit with system separation

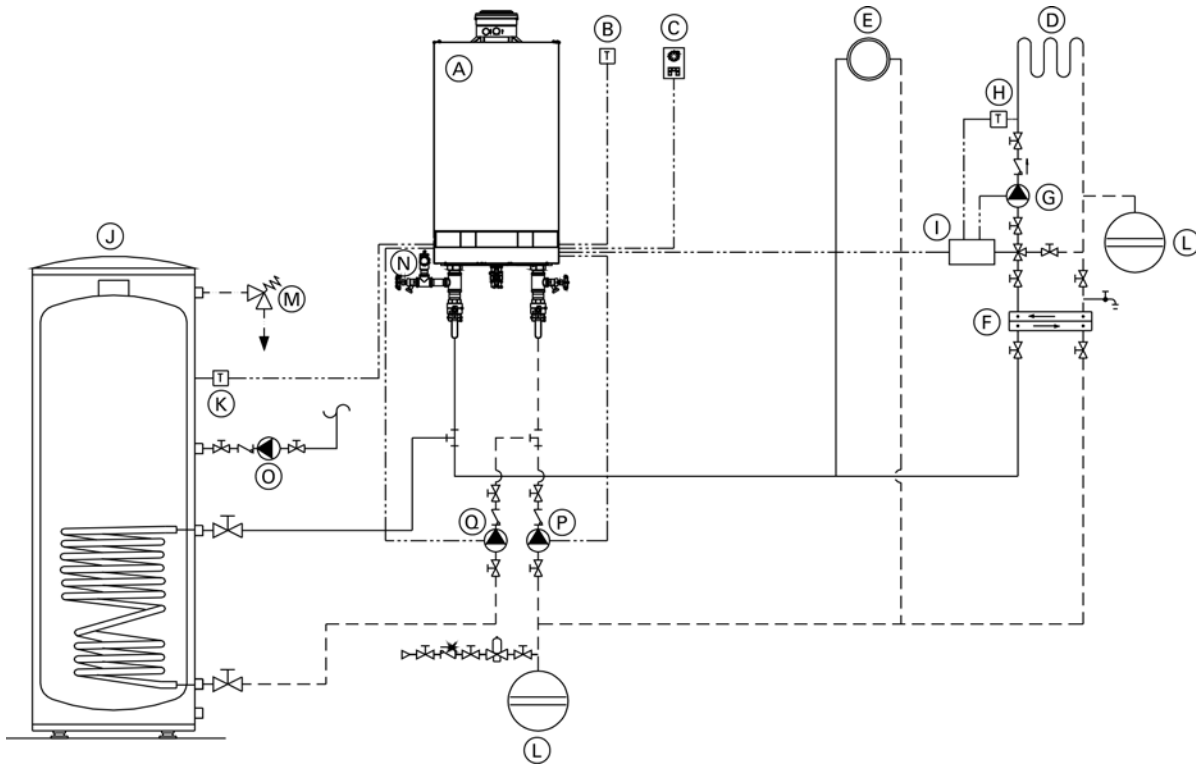

Legend

- (A) Vitodens 200-W B2HA boiler with Vitotronic 200, HO1B outdoor reset control
- (B) Outdoor temperature sensor [1]
- (C) Vitotrol remote (optional)
- (D) Under floor heating circuit
- (E) Radiator heating circuit
- (F) Plate heat exchanger for system separation
- (G) Heating circuit pump
- (H) Mixing valve temperature sensor [2]
- (I) Accessory kit for heating circuit with mixing valve
- (J) DHW storage tank
- (K) DHW tank temperature sensor [5]
- (L) Expansion tanks
- (M) Temperature and pressure relief valve
- (N) Pressure relief valve
- (O) DHW recirculation pump [28/20] *
- (P) Boiler pump [20]
- (Q) DHW circulating pump [21]

* Function based on coding of address 53

Installation of different heating circuits...

- radiator heating circuit (high-temp. circuit)
- under floor heating circuit with 3-way mixing valve (low-temp. circuit)
- DHW production

... with the following flow conditions:

The total flow rate of the two heating circuits is less than the maximum possible water flow rate of the Vitodens 200-W B2HA boiler (see page 10 for maximum water flow rate of boiler).

The use of a low-loss header is strongly recommended if the maximum water flow rate in the application concerned exceeds the max. boiler flow rate, or if the system flow rates are unknown. The low-loss header is available as accessory part.

The 3-way mixing valve, built-in to achieve the low-temperature level of the under floor heating circuit, is controlled by an accessory kit for a heating circuit with mixing valve (I). The boiler pump [20] supplies the radiator heating circuit and the plate heat exchanger for system separation.

IMPORTANT

DHW circulating pump (Q) must pump into the Vitodens 200-W B2HA boiler (as illustrated).

IMPORTANT

The pressure drop (secondary circuit) of the plate heat exchanger (F) must be less/equal to the pressure drop of the 3-way mixing valve. This must be taken into account when sizing the plate heat exchanger.

System Layout 8

Vitodens 200-W, B2HA with...

- DHW storage tank
- low-loss header
- multiple heating circuits with mixing valves
- one heating circuit without mixing valve

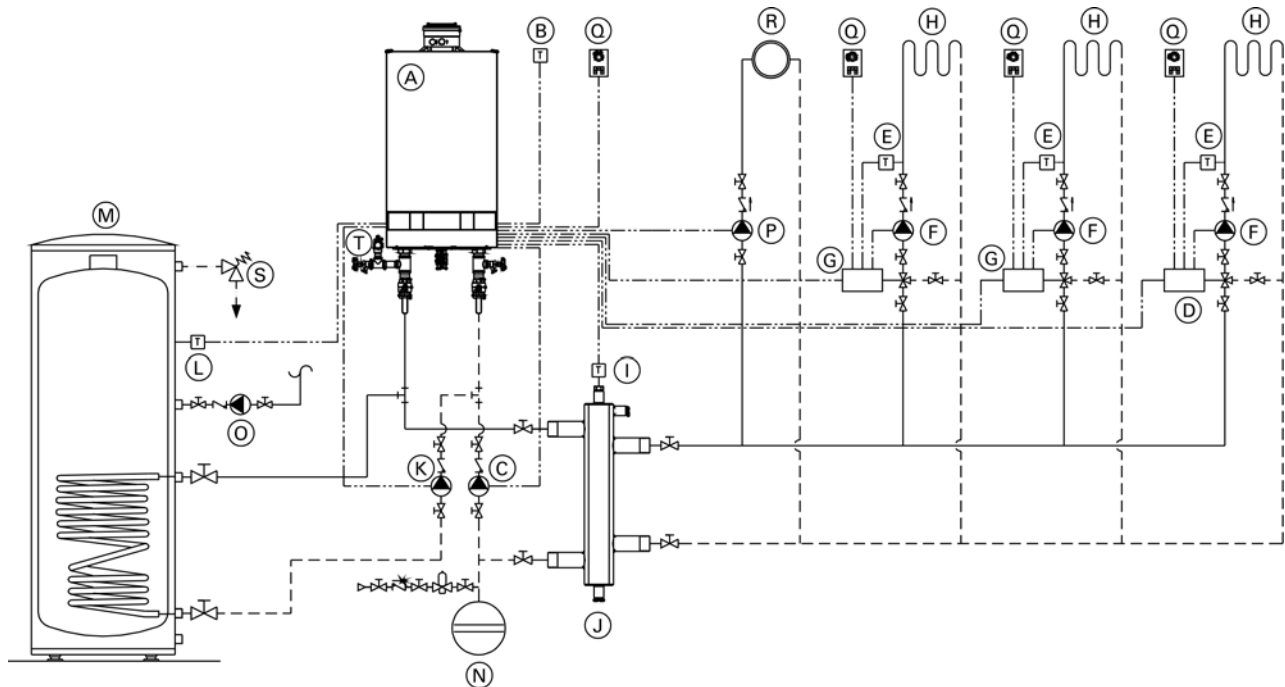

When designing a system as illustrated above, please contact your local Viessmann Sales Representative for assistance.

Legend

- (A) Vitodens 200-W B2HA boiler with Vitotronic 200, HO1B outdoor reset control
- (B) Outdoor temperature [1]
- (C) Boiler pump [20]
- (D) Vitotronic 200-H, HK1B *1
- (E) Mixing valve temperature sensor [2]
- (F) Heating circuit pumps
- (G) Accessory kit for heating circuit with mixing valve
- (H) Heating circuits with mixing valves
- (I) Viessmann temperature sensor for low-loss header [2]
- (J) Low-loss header
- (K) DHW circulating pump [21]
- (L) DHW tank temperature sensor [5]
- (M) DHW storage tank
- (N) Expansion tank
- (O) DHW recirculation pump [28]
- (P) Heating circuit pump [28/20]*
- (Q) Vitotrol remote (optional)
- (R) Radiator heating circuit
- (S) Temperature and pressure relief valve
- (T) Pressure relief valve

* Function based on coding of address 53

*1 Contact your local Sales Representative for details.

Vitotronic 200-H, HK1B mixing valve control with LON communication module can be used instead of the accessory kit and Vitocontrol.

IMPORTANT

Please note location of expansion tank (N).

IMPORTANT

Pumps (C) and (K) must pump into the Vitodens 200-W B2HA boiler (as illustrated).

System Layout 9

Multiple (up to eight) Vitodens 200-W, models B2HA 45 to 80, 285 with...

- multiple heating circuits with mixing valves
- low-loss header

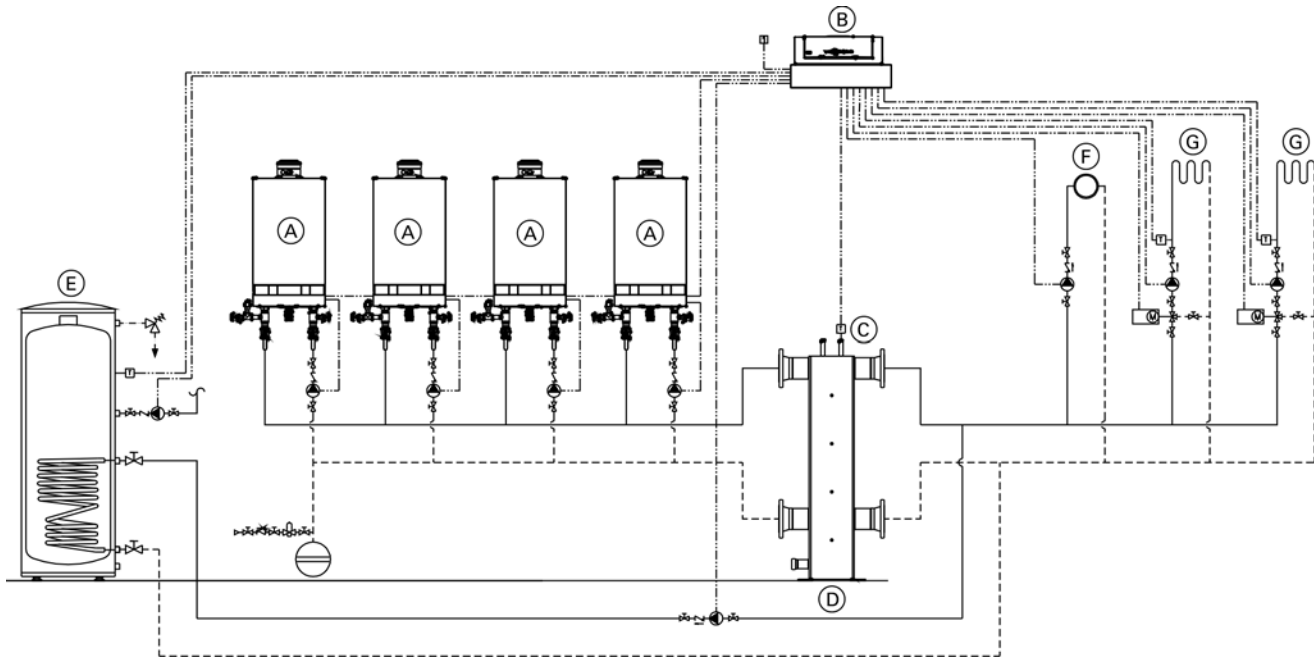

Legend

- (A) Vitodens boiler
- (B) Vitotronic 300K
- (C) Low-loss header/common supply temperature sensor
- (D) Low-loss header
- (E) DHW storage tank
- (F) High temperature heating circuit
- (G) Low temperature heating circuit

When designing a multiple Vitodens system as shown above, please reference applicable multiple Vitodens technical documentation, and contact your local Viessmann Sales Representative for further assistance.

This installation example depicts a possible piping layout for multiple Vitodens 200-W, B2HA boilers equipped with Viessmann System Technology. Please note that this example is based on a simplified conceptual drawing only! Piping and necessary componentry must be field verified. A low water cut-off (LWCO) must be installed where required by local codes.

Proper installation and functionality in the field is the responsibility of the heating contractor.



WARNING

If a DHW storage tank other than a Viessmann Vitocell 100 or 300 tank is used, the installer must verify proper operation of the Viessmann DHW tank temperature sensor with the original manufacturer of the tank. Viessmann strongly recommends the installation of a temperature tempering valve in the DHW supply line.

Alternative DHW Connection

The following piping diagram reflects an alternative connection for the DHW tank only and applies to system layouts 2, 5, 6 and 8. The boiler control pump logic function must be programmed in the Service Instructions.

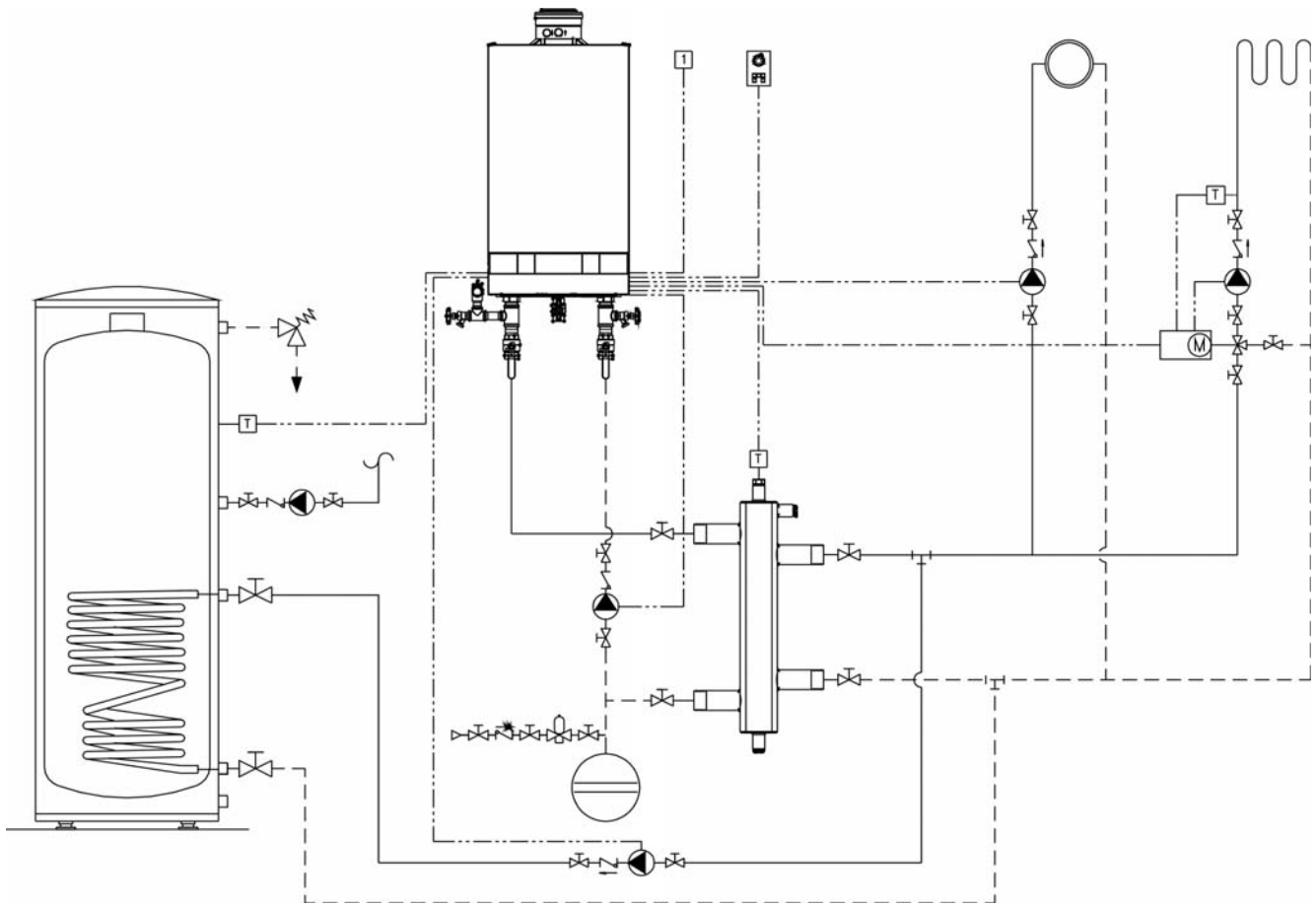

***Note:** When using a low loss header in the system, the DHW connections can be made downstream of the low loss header. See Vitodens 200-W B2HA Service Instructions for applicable system coding information (see coding level 2):

- 00: ...
- A2: ...
- 5b: ...

Overview of Electrical Connections, Models B2HA 19, 28 and 35

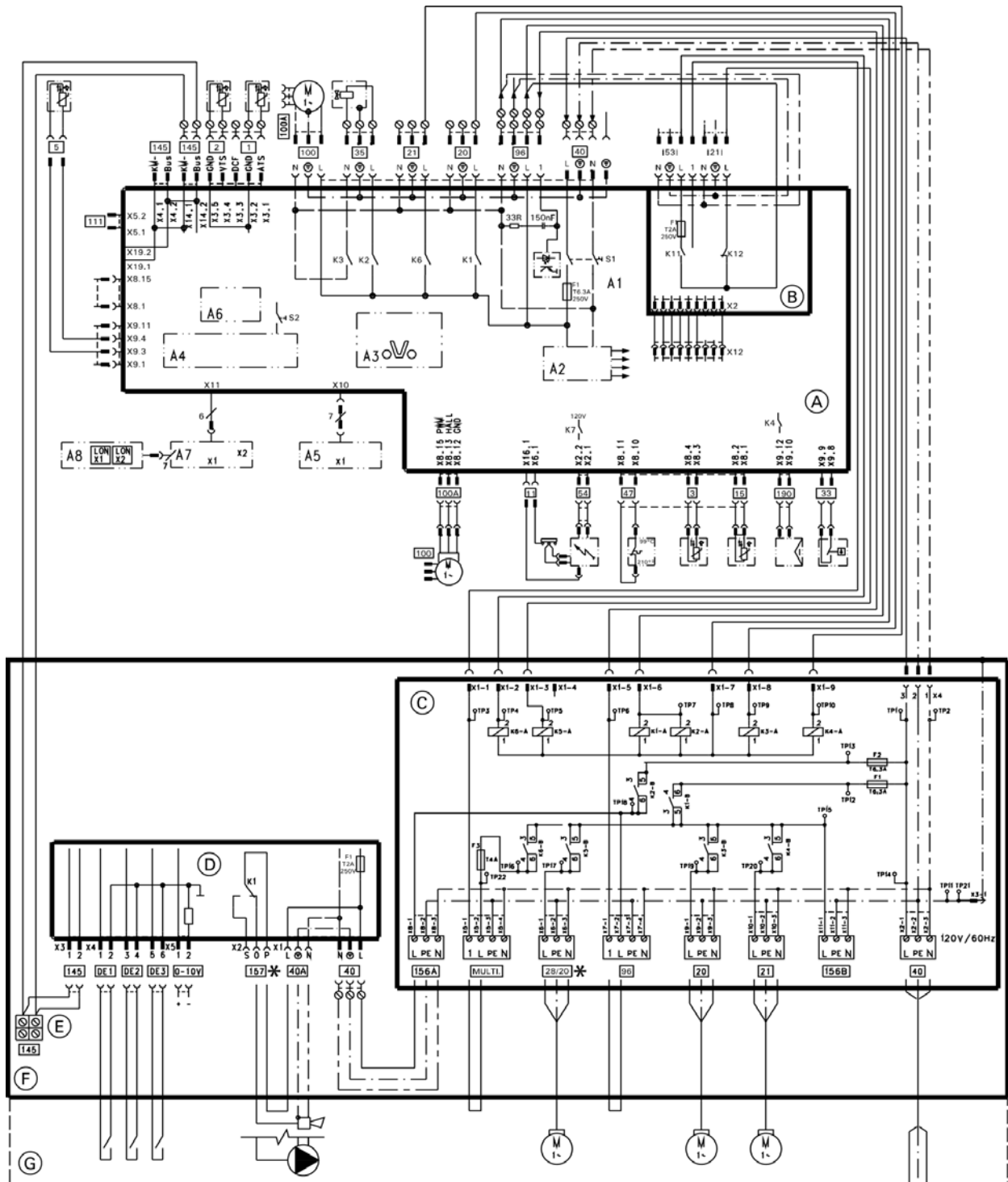

⚠ WARNING
DISCONNECT POWER BEFORE SERVICING BOILER.

If any of the original wires as supplied with the appliance must be replaced, it must be replaced with the exact equivalent.

⚠ CAUTION
 Label all wires prior to disconnection when servicing controls. Wiring errors can cause improper and dangerous operation. Verify proper operation after servicing.

* Only one function/accessory may be assigned to each connection.

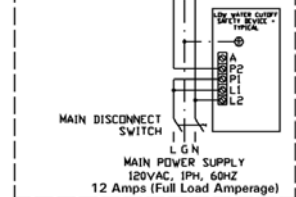

Overview of Electrical Connections, Models B2HA 19, 28 and 35 *(continued)***Legend**

1	Outdoor Temperature Sensor
2	Supply Temperature Sensor/Low Loss Header
3	Boiler Temperature Sensor
5	DHW Temperature Sensor
11	Ionization Electrode
15	Flue Gas temperature Sensor
20	Boiler Pump
21	DHW Pump
[21]	Pump Output Connection
28/20	Programmable Pump Output*
33	Flow Switch
35	Gas Valve
40	Power Supply
40A	Accessory Power Output
47	Fixed High Limit
[53]	Powered Accessory Connection
54	Ignition Transformer
96	Powered Accessory Connection
100	Fan Motor
100A	Fan Motor Control
111	Not Used
145	KM BUS
Multi	Powered Accessory Connection
156A	Switched Output F2
156B	Switched Output F1
DE1	Digital Input 1 (Dry Contact)
DE2	Digital Input 2 (Dry Contact)
DE3	Digital Input 3 (Dry Contact)
0-10V	0-10VDC Input
157	Fault Alarm/DHW Recirc. Pump*
190	Gas Modulation Coil

* See wiring diagram

- Ⓐ Boiler Control
- Ⓑ External Accessory Connection Board
- Ⓒ Pump Connection Interface
- Ⓓ Extension Module EA1
- Ⓔ KM-BUS for External Devices
- Ⓕ Electrical Junction Box
- Ⓖ Field Wiring Connections
- A1 Main Board
- A2 Internal Power Supply Unit
- A3 Optolink
- A4 Burner Control Unit
- A5 Programming Unit
- A6 Coding Card
- A7 Connection Adaptor
- A8 LON Communication Module
- S1 ON/OFF Switch
- S2 Reset Button
- X.. Electrical Interface

IMPORTANT

Electrical installations must comply with the latest edition of:

- In the U.S.A., the National Electrical Code (NEC), ANSI/NFPA 70 and any other state, local codes and/or regulations.
- In Canada, the Canadian Electrical Code (CEC), CSA C22.1 Part 1 and any other province, territory, local codes and/or regulations.

Overview of Electrical Connections, Models B2HA 45 and 60

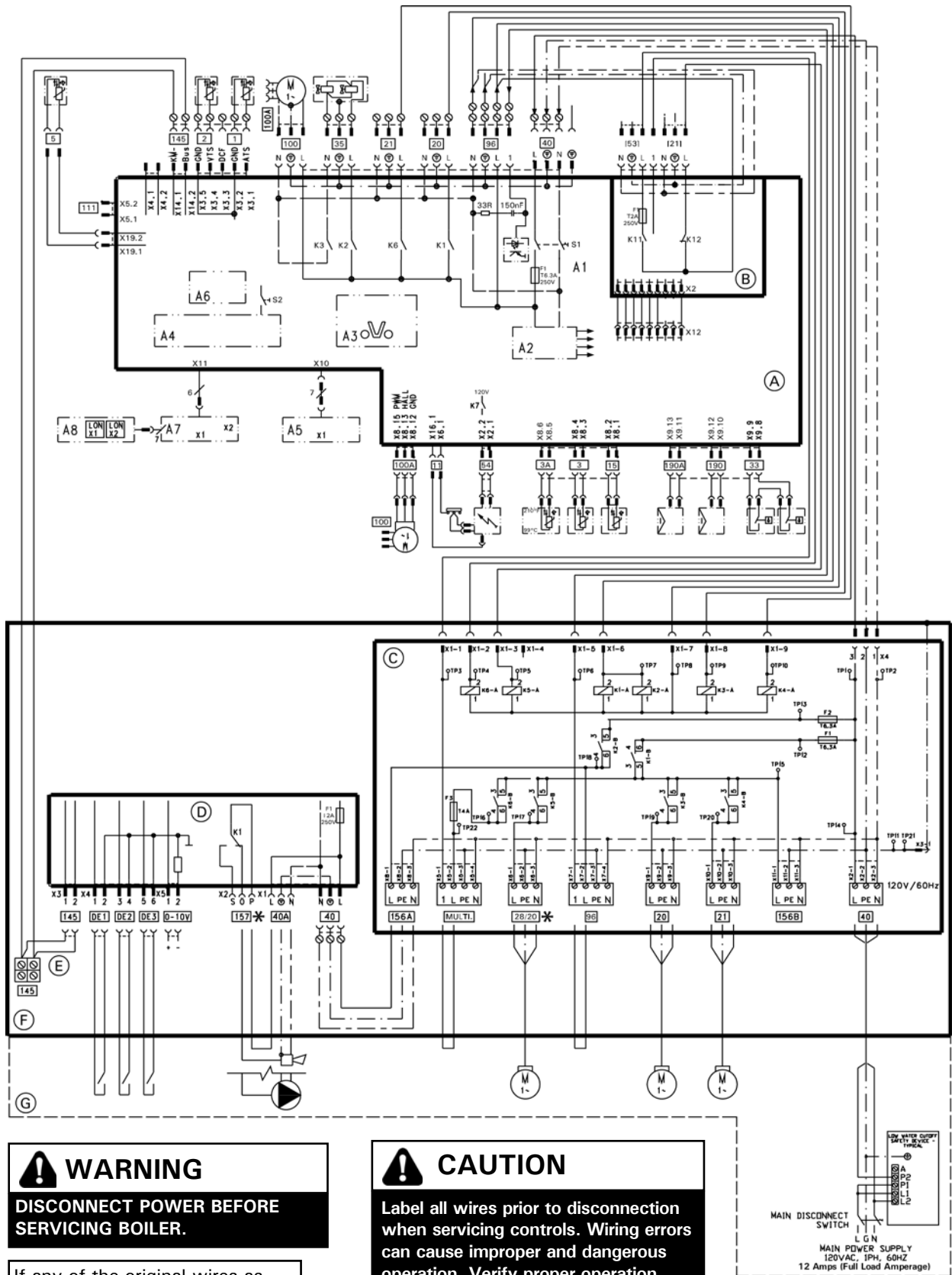

⚠ WARNING
DISCONNECT POWER BEFORE SERVICING BOILER.

If any of the original wires as supplied with the appliance must be replaced, it must be replaced with the exact equivalent.

⚠ CAUTION
 Label all wires prior to disconnection when servicing controls. Wiring errors can cause improper and dangerous operation. Verify proper operation after servicing.

* Only one function/accessory may be assigned to each connection.

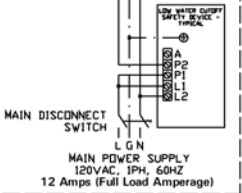

Overview of Electrical Connections, Models B2HA 45 and 60 *(continued)***Legend**

1	Outdoor Temperature Sensor
2	Supply Temperature Sensor/Low Loss Header
3	Boiler Temperature Sensor/High Limit Sensor
3A	Boiler Temperature Sensor/High Limit Sensor
5	DHW Temperature Sensor
11	Ionization Electrode
15	Flue Gas temperature Sensor
20	Boiler Pump
21	DHW Pump
[21]	Pump Output Connection
28/20	Programmable Pump Output*
33	Flow Switch (only one for models 45/60)
35	Gas Valve (only one for models 45/60)
40	Power Supply
40A	Accessory Power Output
[53]	Powered Accessory Connection
54	Ignition Transformer
96	Powered Accessory Connection
100	Fan Motor
100A	Fan Motor Control
111	Not Used
145	KM-BUS
Multi	Powered Accessory Connection
156A	Switched Output F2
156B	Switched Output F1
DE1	Digital Input 1 (Dry Contact)
DE2	Digital Input 2 (Dry Contact)
DE3	Digital Input 3 (Dry Contact)
0-10V	0-10VDC Input
157	Fault Alarm/DHW Recirc. Pump*
190	Gas Modulation Coil
190A	Gas Modulation Coil (N/A for models 45/60)

* See wiring diagram

- Ⓐ Boiler Control
- Ⓑ External Accessory Connection Board
- Ⓒ Pump Connection Interface
- Ⓓ Extension Module EA1
- Ⓔ KM-BUS for External Devices
- Ⓕ Electrical Junction Box
- Ⓖ Field Wiring Connections
- A1 Main Board
- A2 Internal Power Supply Unit
- A3 Optolink
- A4 Burner Control Unit
- A5 Programming Unit
- A6 Coding Card
- A7 Connection Adaptor
- A8 LON Communication Module
- S1 ON/OFF Switch
- S2 Reset Button
- X.. Electrical Interface

IMPORTANT

Electrical installations must comply with the latest edition of:

- In the U.S.A., the National Electrical Code (NEC), ANSI/NFPA 70 and any other state, local codes and/or regulations.
- In Canada, the Canadian Electrical Code (CEC), CSA C22.1 Part 1 and any other province, territory, local codes and/or regulations.

Overview of Electrical Connections, Models B2HA 80, 285

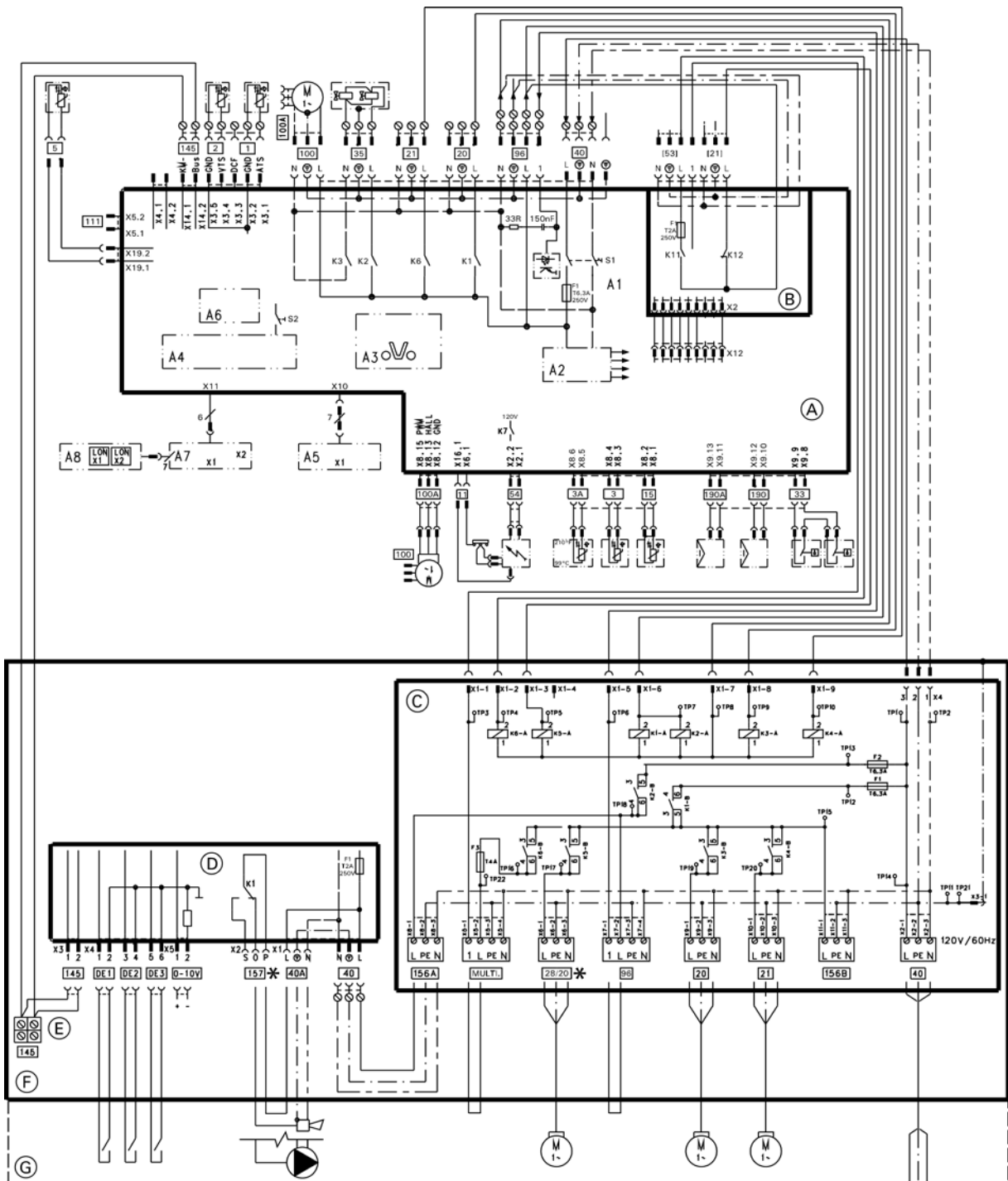

WARNING
 DISCONNECT POWER BEFORE SERVICING BOILER.

If any of the original wires as supplied with the appliance must be replaced, it must be replaced with the exact equivalent.

CAUTION
 Label all wires prior to disconnection when servicing controls. Wiring errors can cause improper and dangerous operation. Verify proper operation after servicing.

* Only one function/accessory may be assigned to each connection.

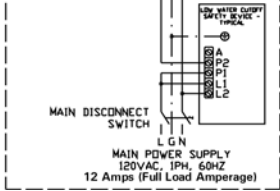

Overview of Electrical Connections, Models B2HA 80, 285 *(continued)*

Legend

1	Outdoor Temperature Sensor
2	Supply Temperature Sensor/Low Loss Header
3	Boiler Temperature Sensor/High Limit Sensor
3A	Boiler Temperature Sensor/High Limit Sensor
5	DHW Temperature Sensor
11	Ionization Electrode
15	Flue Gas temperature Sensor
20	Boiler Pump
21	DHW Pump
[21]	Pump Output Connection
28/20	Programmable Pump Output*
33	Flow Switch (X2 FOR MODELS 80/88/100)
35	Gas Valve (X2 FOR MODELS 80/88/100)
40	Power Supply
40A	Accessory Power Output
[53]	Powered Accessory Connection
54	Ignition Transformer
96	Powered Accessory Connection
100	Fan Motor
100A	Fan Motor Control
111	Not Used
145	KM-BUS
Multi	Powered Accessory Connection
156A	Switched Output F2
156B	Switched Output F1
DE1	Digital Input 1 (Dry Contact)
DE2	Digital Input 2 (Dry Contact)
DE3	Digital Input 3 (Dry Contact)
0-10V	0-10VDC Input
157	Fault Alarm/DHW Recirc. Pump*
190	Gas Modulation Coil
190A	Gas Modulation Coil (for 80, 88, 100, 285, 311, 352)

* See wiring diagram

- Ⓐ Boiler Control
- Ⓑ External Accessory Connection Board
- Ⓒ Pump Connection Interface
- Ⓓ Extension Module EA1
- Ⓔ KM-BUS for External Devices
- Ⓕ Electrical Junction Box
- Ⓖ Field Wiring Connections
- A1 Main Board
- A2 Internal Power Supply Unit
- A3 Optolink
- A4 Burner Control Unit
- A5 Programming Unit
- A6 Coding Card
- A7 Connection Adaptor
- A8 LON Communication Module
- S1 ON/OFF Switch
- S2 Reset Button
- X.. Electrical Interface

IMPORTANT

Electrical installations must comply with the latest edition of:

- In the U.S.A., the National Electrical Code (NEC), ANSI/NFPA 70 and any other state, local codes and/or regulations.
- In Canada, the Canadian Electrical Code (CEC), CSA C22.1 Part 1 and any other province, territory, local codes and/or regulations.

System Design Considerations

IN THE COMMONWEALTH OF MASSACHUSETTS...

- this product shall be installed by a licensed plumber or gas fitter.
- the flexible connector (if used) cannot exceed 36".
- any level type shutoff used must be of tee handle type.

Boiler location

As a direct vent appliance, the Vitodens 200-W can be installed for room air independent operation (sealed combustion) regardless of size and ventilation method of the room in which it is located.

The Vitodens 200-W can be installed, for example, in the main living area of a house, in non-ventilated utility rooms, cupboards, closets and alcoves with no clearance required from combustible materials, as well as in attics with a direct outlet for the flue gas/fresh air system. Follow all local and national codes.

Flue gas system

PPS (Polypropylene) concentric flue gas/fresh air systems for room air independent operation (sealed combustion) and side wall venting are tested to ANSI Z21.13 - CSA 4.9 - 2000 standards and are certified together with the Vitodens 200-W boiler as a constructional unit.

The Vitodens 200-W boiler may also be vented vertically, using an AL29-4C® special stainless steel, single-wall, room air dependent venting system (UL listed for category IV). For a more detailed description of the direct vent and single-wall vent system, please refer to the Vitodens 200-W Venting System Installation Instructions.

Flue gas temperature protection

Flue pipes used for the Vitodens 200-W are suitable for max. flue gas temperatures of up to 230°F (110°C). No flue gas temperature protection is required as the maximum permissible flue gas temperature is not exceeded in any operating condition or in the event of malfunctioning.

Low water cut-off

A low water cut-off may be required by local codes. If the boiler is installed above the radiation level, a low water cut-off device of approved type must be installed in all instances. An approved type low water cut-off device must be provided by the heating contractor. Do not install an isolation valve between the boiler and the low water cut-off.

Water connections

Vitodens 200-W boilers can be used in any fully pumped hot water heating system.

Minimum system pressure is 1 bar (14 psig).

Chemical corrosion protection products

Corrosion does not typically occur in sealed heating systems which have been correctly installed and are correctly operated.

Many manufacturers of plastic pipes recommend the use of chemical additives. In this case, only those commercially available corrosion protection products approved for boilers with domestic hot water heating via single-wall heat exchangers (instantaneous plate heat exchangers or DHW tanks) must be used.

Water quality

Treatment for boiler feed water should be considered in areas of known problems, such as where a high mineral content and hardness exist. In areas where freezing might occur, an antifreeze may be added to the system water to protect the system. Please adhere to the specifications given by the antifreeze manufacturer. Do not use automotive silicate based antifreeze.

Please observe that an antifreeze/water mixture may require a backflow preventer within the automatic water feed and influence components such as diaphragm expansion tanks, radiation, etc. Maximum antifreeze content is 50% for the Vitodens 200-W boiler. Do not use antifreeze other than specifically made for hot water heating systems. System also may contain components which might be negatively affected by antifreeze. Check total system frequently when filled with antifreeze. Advise system operator/ultimate owner that system is filled with a glycol mix. The heating contractor must provide a MSDS (Material Safety Data Sheet) for the antifreeze used to the system operator/ultimate owner.

Total permissible hardness of the fill and top-up water

Total heating output	Specific heating volume					
	< 5 USG per 3412 BTU		≥ 5 USG per 3412 BTU to < 13 USG per 3412 BTU		≥ 13 USG per 3412 BTU	
MBH						
≤ 170	300 ppm	17.5 gpg	200 ppm	11.7 gpg	2 ppm	0.11 gpg
> 170 to ≤ 682	200 ppm	11.7 gpg	150 ppm	8.8 gpg	2 ppm	0.11 gpg
> 682 to ≤ 170	150 ppm	8.8 gpg	2 ppm	0.11 gpg	2 ppm	0.11 gpg
> 2050	2 ppm	0.11 gpg	2 ppm	0.11 gpg	2 ppm	0.11 gpg

ppm - parts per million
gpg - grains per gallon

Note: The pH value of the heating water should be between 6.5 and 9.5

System Design Considerations *(continued)*

System layout

- The max. boiler water temperature for space heating and DHW production is 165°F (74°C) for models B2HA 19 to 60 or 185°F (85°C) for model B2HA 80, 285. To minimize distribution losses, Viessmann recommends that the heating and domestic hot water systems be based on a maximum boiler supply temperature of 158°F (70°C).
- Due to the low return temperatures required for gas condensing, no mixing valves should be used in the heating circuit whenever possible. If mixing valves are required, e.g. for multi-circuit systems or underfloor heating systems, only 3-way mixing valves must be used.
Do not use 4-way mixing valves with condensing boilers.

Underfloor heating systems

For underfloor heating systems Viessmann recommends the use of plastic tubing with an oxygen diffusion barrier in order to prevent the diffusion of oxygen through tubing. If plastic tubing without an oxygen diffusion barrier is used in underfloor heating systems, Viessmann recommends that such systems be separated from the boiler with a heat exchanger.

Underfloor heating systems and heating circuits containing a very large volume of water must be connected to the boiler via a 3-way mixing valve; please refer to the applicable installation example in this manual.

Oxygen diffusion barrier underfloor tubing

The boiler warranty does not cover leaks resulting from corrosion caused by the use of underfloor plastic tubing without an oxygen diffusion barrier. Such systems must have the non-oxygen diffusion barrier tubing separated from the boiler with a heat exchanger. Viessmann recommends the use of underfloor plastic tubing with an oxygen diffusion barrier.

Warranty

Our warranty does not cover damages resulting from the following:

- installation or service by unqualified and unlicensed personnel.
- attempting to perform any repair work on the boiler other than that mentioned in the boiler literature.
- tampering with or attempting, without Viessmann permission, to readjust the factory settings of the;
 - combination gas valve
 - combustion air opening of the burner blower
- leaks resulting from corrosion caused by the use of underfloor plastic tubing without an oxygen diffusion barrier. For detailed warranty information, please read warranty sheet supplied with product.

Quick Reference

°C	°F
-40	-40
-35	-31
-25	-13
-20	-4
-18	0
-16	+3
-14	+7
-12	+10
-10	+14
-9	+16
-8	+18
-7	+19
-6	+21
-5	+23
-4	+25
-3	+27
-2	+28
-1	+30
0	+32
+1	+34
+2	+36
+3	+37
+4	+39
+5	+41
+6	+43
+7	+45
+8	+46
+9	+48
+10	+50
+12	+54
+14	+57
+16	+61
+18	+64
+20	+68
+25	+77
+30	+86
+35	+95
+40	+104
+50	+122
+60	+140
+70	+158
+80	+176
+90	+194
+100	+212
+110	+230

Viessmann Manufacturing Company Inc.
 750 McMurray Road
 Waterloo, Ontario • N2V 2G5 • Canada
TechInfo Line 1-888-484-8643
 1-800-387-7373 • Fax (519) 885-0887
 www.viessmann.ca • info@viessmann.ca

Viessmann Manufacturing Company (U.S.) Inc.
 45 Access Road
 Warwick, Rhode Island • 02886 • USA
TechInfo Line 1-888-484-8643
 1-800-288-0667 • Fax (401) 732-0590
 www.viessmann-us.com • info@viessmann-us.com

Printed on environmentally friendly
 (recycled and recyclable) paper.



Technical information subject to change without notice.