



CONDENSING GAS FIRED

INSTALLATION, OPERATION & MAINTENANCE MANUAL

Models

MAHF-125, MACF-150



Manufactured by:
ECR International Inc.
2201 Dwyer Avenue, Utica, NY 13501
Tel. 800 253 7900
www.ecrinternational.com
PN 240012565 REV. A [05/15/2019]

VERIFY CONTENTS RECEIVED

			
<p>Fully Assembled Boiler</p>	<p>30 PSI Safety Relief Valve</p>	<p>Temperature Pressure Gauge (2" Shank)</p>	<p>G3/4 NPT Ball Gas Shutoff Valve</p>
	<p>4ea - 17x24x2" Gaskets 4ea - 1/2" AFM Gaskets</p>	<p>Includes Essential Documents and Warranty 11x17 Wire Diagrams</p>	
<p>DHW Optional Pipe Heat Only Boiler</p>	<p>Used for Valve Connections</p>	<p>Document Package</p>	

TABLE OF CONTENTS

Verify contents received.....	2	9.12 Chimney Sweep Function (CO2 Adjust)	41
Table of contents.....	3	9.13 Combustion Adjustment Function (CO2%)	41
Physical Data.....	4	9.14 Check Firing Rate	41
1 - Important Information.....	6	9.15 Description Of Parameters: Factory Settings	42
2 - Introduction.....	7	9.16 Adjusting Maximum Heating Power	44
3 - Component Listing	8	10 - Operating instructions	45
4 - Locating Boiler	10	10.1 Testing For Gas Leaks And Purging The Gas Supply	45
5 - Combustion Air And Vent Piping.....	12	10.2 Boiler Operation	45
5.1 General.....	12	10.3 Central Heating Mode.....	45
5.2 Removal of Existing Boiler From Common Vent System	12	10.4 Domestic Hot Water Mode	45
5.3 Definitions.....	13	10.5 Frost Protection.....	45
5.4 Approved Venting Materials	14	10.6 Pump.....	45
5.5 Vent Termination.....	14	10.7 Low Water Pressure Sensor (Internal)	45
5.6 Coaxial Venting Instructions	15	11 - General Maintenance and Cleaning.....	46
5.7 Coaxial Vent Screw Placement	15	11.1 Beginning of Each Heating Season	46
5.8 Twin Pipe Systems.....	17	11.2 Maintenance And Routine Servicing.....	47
5.9 Securing Twin Pipe Polypropylene Venting	18	11.3 Component Replacement And Cleaning	47
5.10 (3" /80 mm Only) Flexible Vent System	21	11.4 Draining the Boiler.....	48
5.11 Condensate Piping.....	23	11.5 Draining the Heating Circuit	48
6 - Hydronic Piping.....	24	11.6 Hydraulic Unit (DHW).....	49
6.1 General.....	24	11.7 Cleaning The Cold Water Filter	49
6.2 Special Conditions	24	11.8 Final Commissioning	49
6.3 Safety Relief Valve and Air Vent	25	11.9 Final Assembly	49
6.4 Trim Piping	25	11.10 User Information	50
6.5 System Piping.....	25	11.11 Safety Flue Thermostat - DO NOT disable this safety device.	50
6.6 External Optional Low Water Cut Off	27	11.12 Flue Pressure Switch- DO NOT disable this safety device.	50
6.7 Central Heating System	29	11.13 Replacement Parts	50
6.8 Domestic Hot Water Mode	29	12 - Ratings And Capacities.....	51
6.9 Frost Protection Mode	29	12.1 Ratings and Capacity	51
6.10 Pump Protection.....	29	12.2 Domestic Hot Water Specifications.....	51
7 - Gas Supply Piping	30	12.3 High Altitude Ratings and Capacity	51
7.1 General.....	30	12.4 High Altitude Chart	51
7.2 Leak Check Gas Piping.....	31	13 - Trouble Shooting.....	52
7.3 Gas Orifice	31	13.1 Error Messages And Resetting The Boiler	52
8 - Electrical Connections	32	13.2 Anomalies Table for the Installer - Use this table to report the anomaly values.	54
8.1 General.....	32	14 - Glossary	55
8.2 Install Room Thermostat	32	Appendix A - Wiring Diagrams.....	57
8.3 Electrical Connections	32	Appendix A - Wiring Diagrams.....	58
8.4 Access To Connection Block	33		
8.5 Main Supply Connection	33		
8.6 Install Room Thermostat	34		
8.7 Optional Electrical Connections.....	34		
8.8 Indirect Storage Tank.....	35		
9 - Start Up Procedure.....	36		
9.1 Central Heating System Connections - Heat Only.....	36		
9.2 Central Heating System Connections - Combi.....	36		
9.3 System Start Up.....	37		
9.4 Fill Condensate Trap with Water	37		
9.5 Control Panel	38		
9.6 Prior to Commissioning	39		
9.7 Commissioning For The First Time:	39		
9.8 Automatic Calibration Function.....	39		
9.9 Manual Calibration Function:	40		
9.10 De-Aeration Function	40		
9.11 Commission Set Up (Gas) - Changing The Type Of	40		
Gas.....	40		

PHYSICAL DATA

Dimensions

DIMENSIONS	125 & 150	
Height (Bottom of boiler top of safety Valve)	43.65" [1.09 m]	
Overall Width with Manifold	24.70" [628 mm]	
Depth	17.46" [444 mm]	
Condensate Trap Connection	3/4" NPT	
System Supply	1 1/4" Sweat Connection	
DHW Outlet (125 Optional)	(125) 3/4" Sweat Connection	(150) 1/2" Sweat Connection
Gas Connection	3/4" NPT	
DHW (Cold Water) Inlet	(125) NA	(150) 1/2" Sweat Connection
System Return	1 1/4" Sweat Connection	
Boiler Filling Connection	External to Boiler	
Primary Water Content	1 gal [3.60 L]	

SYSTEM

Central Heating (Sealed System)	125 / 150
Heat Exchanger Max Allowable Working Pressure	50 psi [3.45 bar]
Max System Pressure	30.00 psi [2.11 bar]
Min System Pressure	7.25 psi [0.50 bar]
Max System temperature	176°F [80°C]
Pressure Relief Valve Setting	30.00 psi [2.11 bar]
Expansion Tank Minimum Size (pre-charge press.)	2.2 gal at 11.6 psi [10.0 L at 0.8 bar]
Recommended System Pressure (cold)	21.7 psi [1.5 bar]

Domestic Hot Water (Sealed System)	150
Max Inlet Water Pressure	116 psi [8 bar]
Min Inlet Water Pressure	2.9 psi [0.2 bar]
Min DHW Flow Rate	0.55 gpm [2.50 L/min]
Max DHW Temperature	140°F [60°C]
DHW Water Content	0.05 gal [0.23 L]

When boiler is operating at maximum operating temperature, providing heating with all heat emitters operating, pressure gauge should not indicate more than 26.11 psi / 1.80 bar. If reading exceeds this figure larger expansion tank is required.

PHYSICAL DATA

Top View All Models

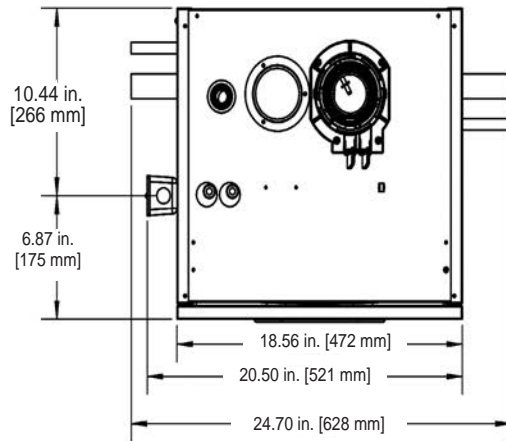

Left Side View All Models

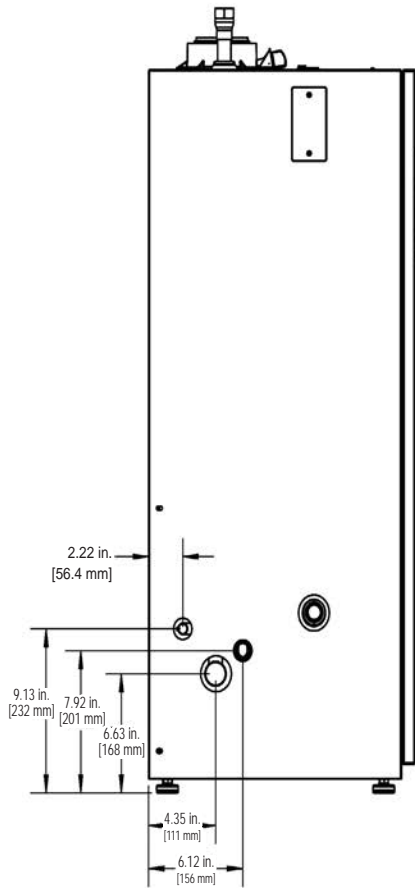

Front View All Models

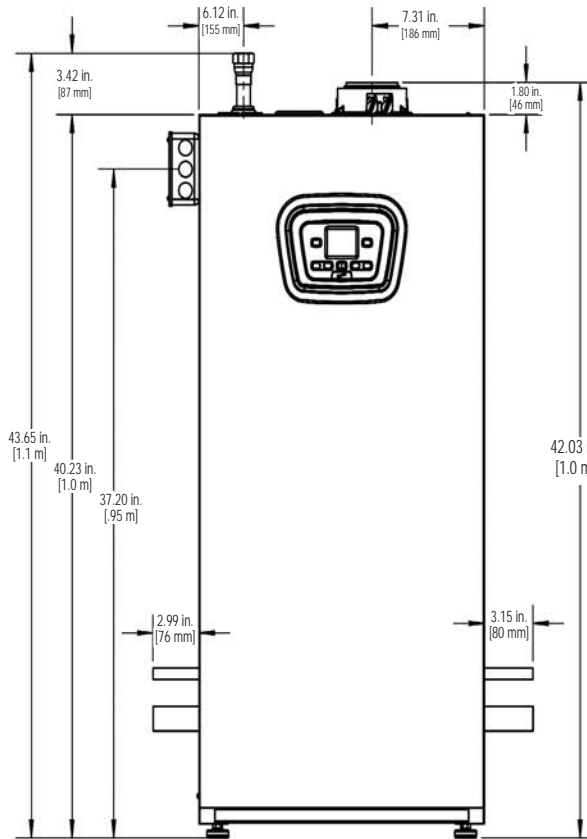

Right Side View All Models

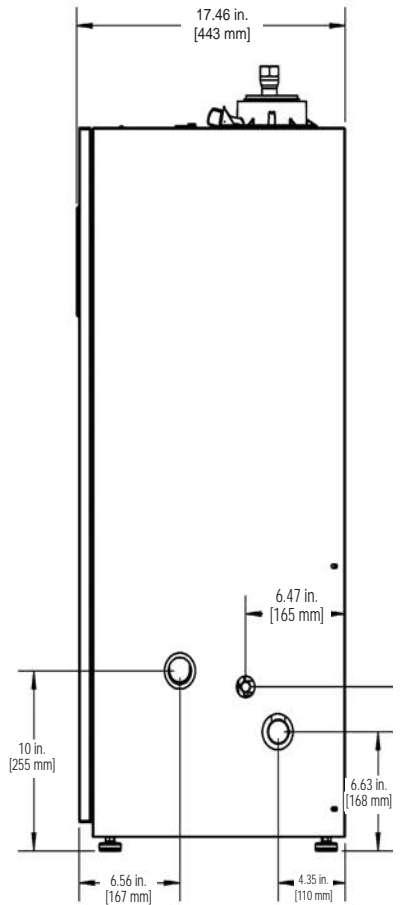

1. Safety Information

Boiler installation shall be completed by qualified agency. See glossary for additional information.

⚠ WARNING

Fire, explosion, asphyxiation and electrical shock hazard. Improper installation could result in death or serious injury. Read this manual and understand all requirements before beginning installation.

⚠ WARNING

Do not tamper with or use this boiler for any purpose other than its intended use. Failure to follow these instructions could result in death or serious injury. Use only manufacturer recommended parts and accessories.

⚠ CAUTION

Laceration, burn hazard. Metal edges and parts may have sharp edges and/or may be hot. Use appropriate personal protection equipment to include safety glasses and gloves when installing or servicing this boiler. Failure to follow these instructions could result in minor or moderate injury.

Become familiar with symbols identifying potential hazards.

 This is the safety alert symbol. Symbol alerts you to potential personal injury hazards. Obey all safety messages following this symbol to avoid possible injury or death.

⚠ DANGER

Indicates a hazardous situation which, if not avoided, WILL result in death or serious injury.

⚠ WARNING

Indicates a hazardous situation which, if not avoided, could result in death or serious injury.

⚠ CAUTION

Indicates a hazardous situation which, if not avoided, could result in minor or moderate injury.

NOTICE

Used to address practices not related to personal injury.

FOR YOUR SAFETY READ BEFORE OPERATING



Hot Water Can Scald!

Water heated to temperature for clothes washing, dish washing and other sanitizing needs can scald and cause permanent injury.

Children, elderly, and infirm or physically handicapped persons are more likely to be permanently injured by hot water. Never leave them unattended in bathtub or shower. Never allow small children to use a hot water tap or draw their own bath.

If anyone using hot water in the building fits the above description, or if state laws or local codes require certain water temperatures at hot water taps, you must take special precautions:

- Use lowest possible temperature setting.
- Install some type of tempering device, such as an automatic mixing valve, at hot water tap or water heater. Automatic mixing valve must be selected and installed according to manufacturer's recommendations and instructions.
- Water passing out of drain valves may be extremely hot. To avoid injury:
 - Make sure all connections are tight.
 - Direct water flow away from any person.

Water Temperature Setting	1st Degree Burn Exposure Time For An Adult	2nd and 3rd Degree Burn Exposure Time For An Adult
120° F	1 minute	5 minutes
130° F	5 seconds	30 seconds
140° F	2 seconds	5 seconds
150° F	1 second	1.5 seconds
160° F	Instantaneous	0.5 seconds

Note: Warning for Infants, Children, and Elderly: Great care must be taken when exposing the aforementioned groups to warm or hot water as they can be badly burned in exposure times less than half of the time for an adult.

2 - Introduction

2.1 Installation shall conform to requirements of authority having jurisdiction or in absence of such requirements:

UNITED STATES

- National Fuel Gas Code, ANSI Z223.1/NFPA 54.
- National Electrical Code, NFPA 70.

2.2 Where required by authority having jurisdiction, installation shall conform to Standard for Controls and Safety Devices for Automatically Fired Boilers, ANSI/ASME CSD-1.

Additional manual reset low water cutoff may be required.

2.3 Requirements for Commonwealth of Massachusetts:

Boiler installation must conform to Commonwealth of Massachusetts code 248 CMR which includes but is not limited to:

Installation by licensed plumber or gas fitter.

2.4 Manufacturer recommends use of Carbon Monoxide monitor may be requirement of local jurisdiction.

2.5 Designated Use

- MACF-150 provide both central heating and domestic hot water.
- MAHF-125 central heating only.
- Indoor installation.
- Closet or alcove installation. Direct Vent Boiler does not require air vents when installed in closet or room.
- Direct vent boiler.
- For use with natural gas or liquefied petroleum gases (LP/propane).

2.6 The unit **MUST NOT**:

- Directly heat potable water. Indirect heating is acceptable.
- Heat water with non-hydronic heating system chemicals present (example, swimming pool water).
- Toxic chemicals, such as those used for boiler treatment, shall not be introduced into potable water used for space heating.
- Exceed 43 psig (2.96 bar) maximum system pressure, or drop below minimum system pressure 7.25 psig (.50 bar)
- Exceed 176°F (80°C) system design temperature.

2.7 Operational Features

- Modulates to provide CH Turndown 5.5:1, DHW Turndown 7:1.
- Maximum output available for domestic hot water:
MACF-150 - 136,000 btu/h (40 kW), capable of providing 3.5 (U.S.) gpm (13.2 liters/min) with a temperature rise of 70°F/39°C.
- Integral Low Water Pressure Cutoff.
- Optional Outdoor Temperature Reset.
- Heat exchanger over heat protection.
- Boiler operating at maximum operating temperature, providing heat, pressure gauge should not indicate more than 26.11 psi / 1.80 bar. If reading exceeds this figure larger expansion tank is required.

Check our website frequently for updates: www.ecrinternational.com

Information and specifications outlined in this manual in effect at the time of printing of this manual. ECR International reserves the right to discontinue, change specifications or system design at any time without notice and without incurring any obligation, whatsoever.

UTICA BOILER MAHF-125

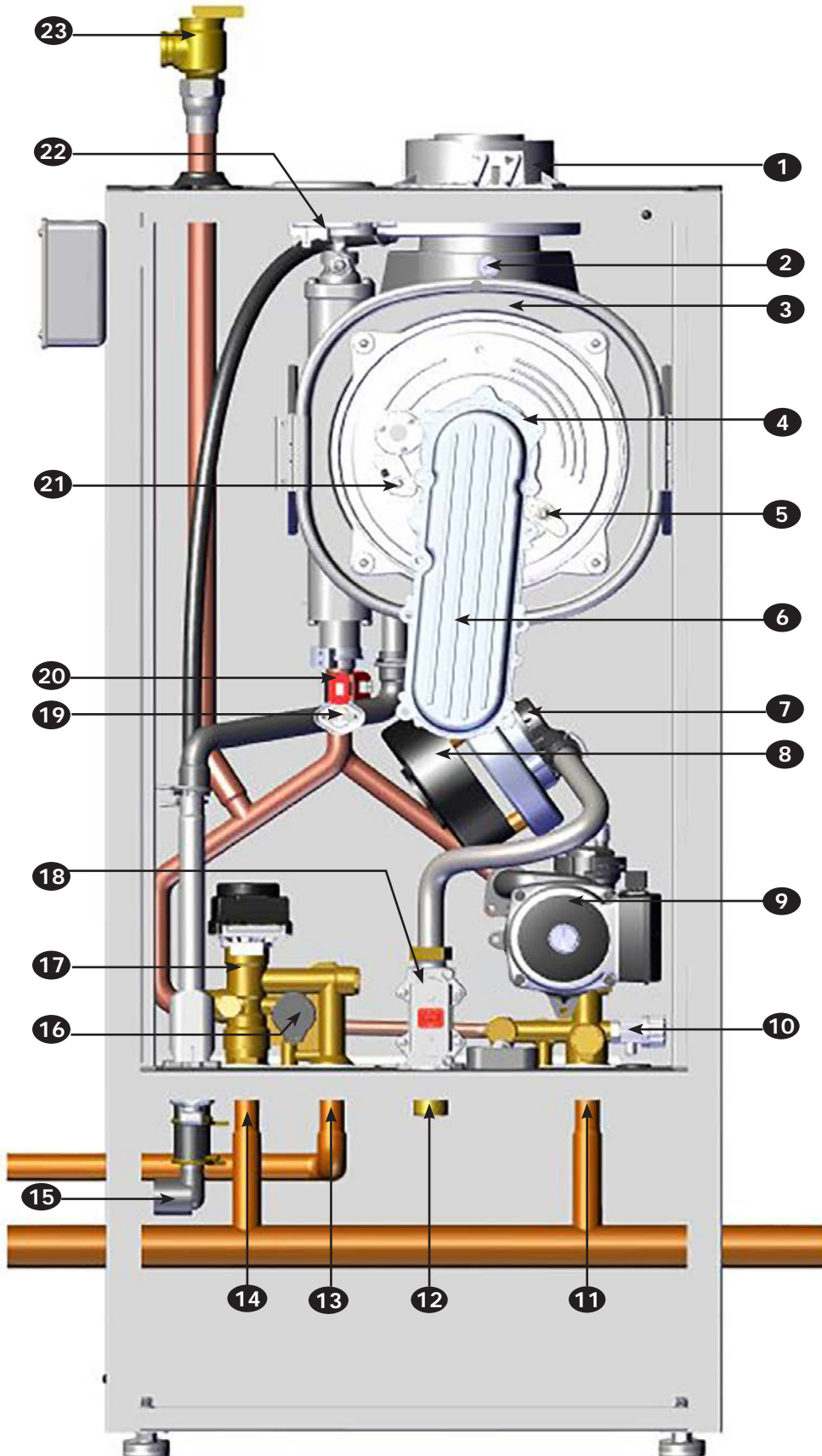

ITEM NO.	Utica Boiler MAHF-125
1	Coaxial Connector
2	Flue Sensor
3	Heat Exchanger
4	Burner (not shown)
5	Flame Detection Electrode
6	Air/Gas Blend Manifold
7	Venturi
8	Fan
9	Pump with Air Separator
10	Boiler Drain Tap
11	Heating Return
12	Gas Inlet
13	Optional Indirect Tank Connection
14	Heating Supply Connection
15	Condensate Connection
16	Low Water Pressure Cutoff
17	3-Way Valve with Motor
18	Gas Valve
19	Water Safety Thermostat
20	NTC Heating sensor (Flow/Return) QTY 2, (1 Shown for clarity)
21	Ignition Electrode
22	Pressure Switch
23	Pressure Relief Valve

Illustrations are a depiction of the boiler for general location of parts and may vary depending on model.

UTICA BOILER MACF-150

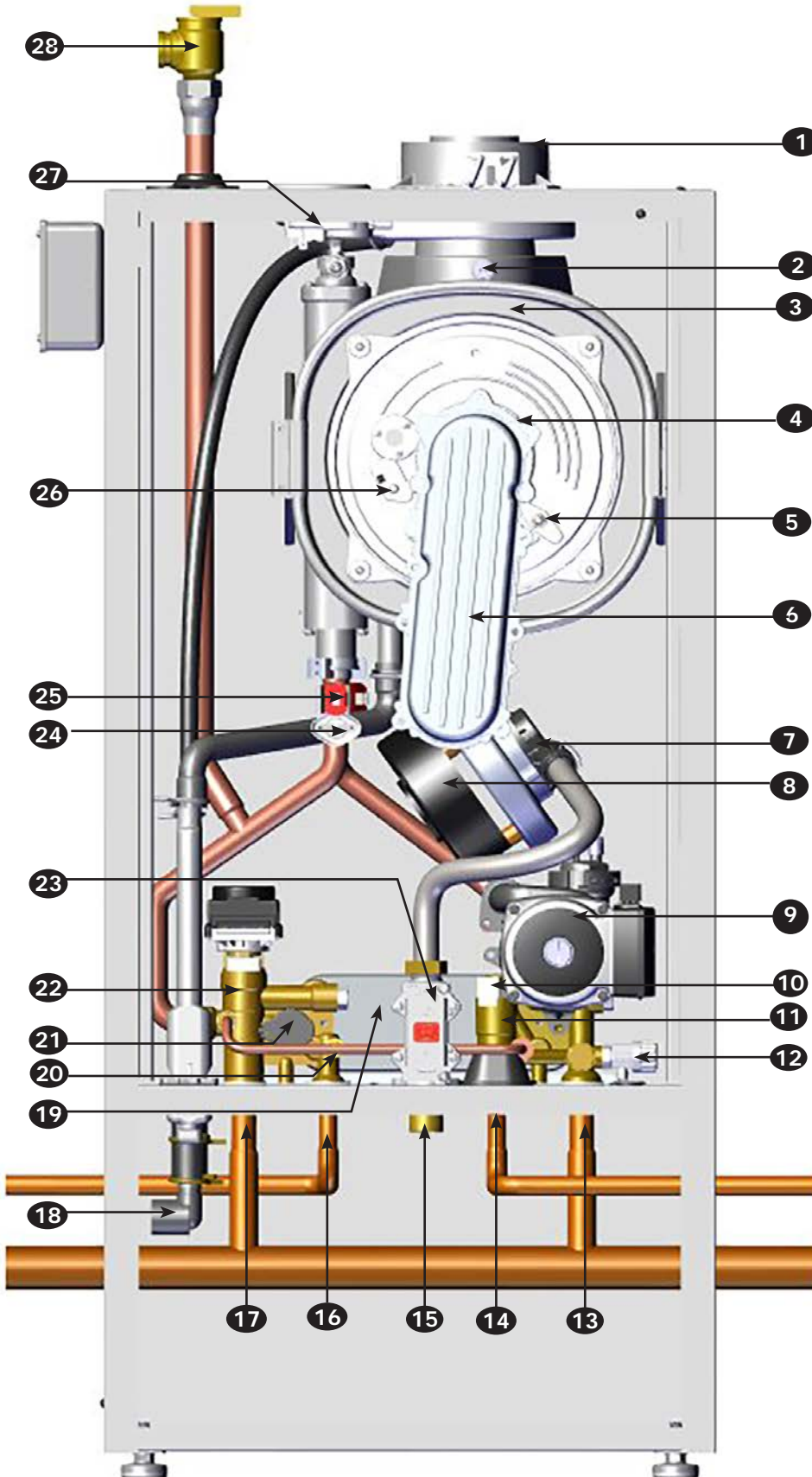

ITEM NO.	Utica Boiler MACF-150
1	Coaxial Connector
2	Flue Sensor
3	Heat Exchanger
4	Burner (not shown)
5	Flame Detection Electrode
6	Air/Gas Blend Manifold
7	Venturi
8	Fan
9	Pump with Air Separator
10	DHW Priority Sensor
11	Flow Sensor with Water Filter and Flow Restrictor
12	Boiler Drain Tap
13	Heating Return
14	Cold Water DHW Inlet Tap
15	Gas Inlet
16	DHW Outlet
17	Heating Supply Connection
18	Condensate Connection
19	DHW Heat Exchanger
20	NTC DHW Sensor
21	Low Water Pressure Cutoff
22	3-Way Valve with Motor
23	Gas Valve
24	Water Safety Thermostat
25	NTC Heating sensor (Flow/Return) QTY 2, (1 Shown for clarity)
26	Ignition Electrode
27	Pressure Switch
28	Pressure Relief Valve

Illustrations are a depiction of the boiler for general location of parts and may vary depending on model.

⚠ WARNING

Fire Hazard! Do not install on carpeting. Failure to follow these instructions could result in death or serious injury.

4.1 Boiler Location Considerations

- Ambient room temperature always above 32°F (0°C) to prevent freezing of liquid condensate.
- Approved for installation in closets or alcove provided it is correctly designed for that purpose and minimum clearances are met.
- Protect gas ignition system components from water (dripping, spraying, rain, etc.) during operation and service (circulator replacement, condensate trap, control replacement, etc.).
- Access to outdoors to meet minimum and maximum pipe lengths for combustion air and vent piping. See section 6.
- Disposal of condensate. See section 6.
- Drainage of water (or water - antifreeze solution) during boiler service or from safety relief valve discharge. See section 5.
- Access to system water piping, gas supply, and electrical service. See sections 5, 7 and 8.
- Clearances to combustible materials and service clearances. See Table 1 and Figures pg. 11.
- Room-sealed boiler installed in a room containing bath or shower shall be installed so person using bath or shower cannot touch any electrical switch or boiler control utilizing line voltage electricity.
- Multiple Boilers can be placed side by side, or back to back.
- Observe service clearances in all installations.
- For Direct Vent installations, air vents are not required in room boiler is installed in, or when installed in closet or compartment.

⚠ WARNING

Fire, explosion, and asphyxiation hazard. Improper installation could result in death or serious injury. Read these instructions and understand all requirements before beginning installation.

⚠ WARNING

Fire hazard. Do not install boiler on combustible flooring or carpeting. Failure to follow these instructions could result in death or serious injury.

4.2 Floor Location

- Place crated boiler as close to selected location as possible and un-crate boiler. Boiler may be moved into position with appliance dolly or 2 wheel hand truck. Insert dolly or hand truck under left hand side of boiler. It is possible to slide boiler for short distance on smooth floor or surface.
- Adjust the position of the boiler verify it is level and plumb.
- Select level location central to piping systems served and as close to vent and air intake terminals as possible.
- Accessibility clearances, if more stringent (i.e. larger clearances) than required fire protection clearances, must be used for boiler installation. Accessibility clearances may be achieved with the use of removable walls or partitions.
- Boiler is approved for installation in closets and on combustible floors. ***This boiler shall NOT be installed on carpeting.***
- Install equipment in location which facilitates operation of venting and combustion air intake piping systems as described in this manual.
- Advise owner to keep venting and combustion air intake passages free of obstructions. Both venting and combustion air intake piping systems connected to outdoors must permit flow through piping systems without restrictions for boiler operation.
- Keep boiler area clean of debris and free of flammable and combustible materials, vapors and liquids.

4 - LOCATING BOILER

4.3 Clearances

TABLE 1: BOILER CLEARANCES		
Dimension	Combustible Materials ⁽¹⁾	Manufacturer Recommended for Service ⁽¹⁾⁽²⁾
Top	0" (0 cm)	8-5/8" (220 mm)
Left Side	1-3/4" (45 mm)	12" (305 mm)
Right Side	1-3/4" (45 mm)	1-3/4" (45 mm)
Front	0" (0 mm)	17-3/4" (450 mm)
Back	0" (0 mm)	0" (0 mm)
Bottom	0" (0 mm)	0" (0 mm)
Combustion Air/Vent piping	0" (0 mm)	6" (160 mm)

(1) Required distances measured from boiler jacket.
(2) Service, proper operation clearance recommendation.
** Allowance for piping and venting not included.*

NOTE: Greater clearances for access should supersede fire protection clearances.

Service Clearances

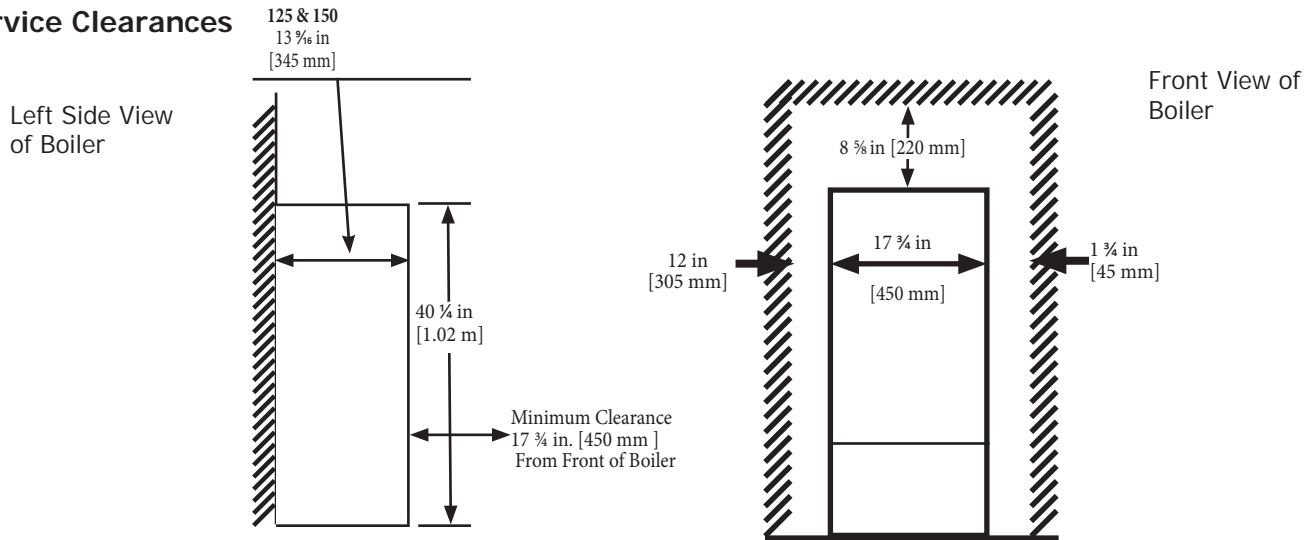

Combustible Clearances

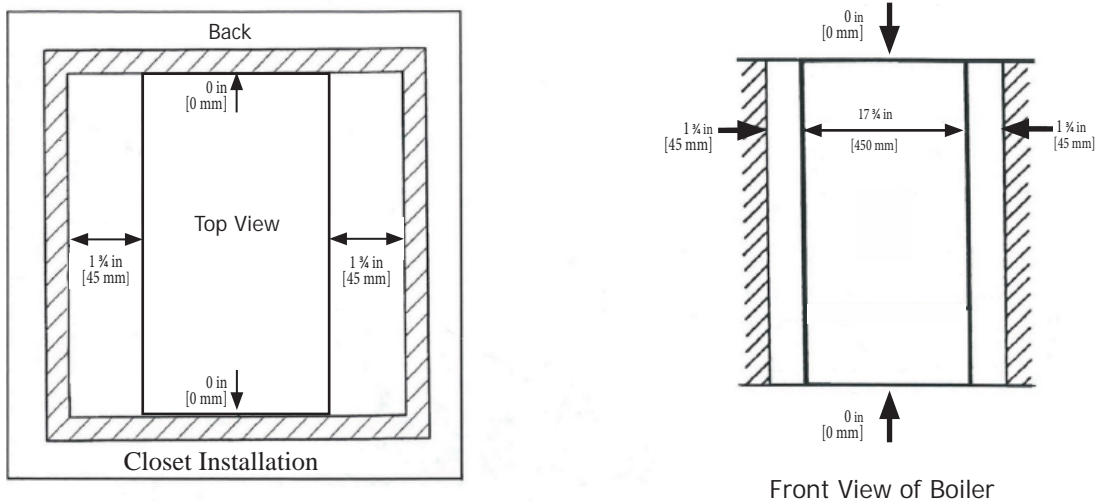

0 in /0 mm between Back of Unit and wall

! WARNING

Fire, explosion, and asphyxiation hazard. Improper installation could result in death or serious injury. Read these instructions and understand all requirements before beginning installation.

! WARNING

ABS/PVC venting shall not be used this product. Use of DWV plumbing pipes to vent this boiler shall be prohibited. Use of cellular core PVC (ASTM F891), cellular core CPVC, or Radel® (polyphenolsulfone) in venting systems shall be prohibited. Covering non-metallic vent pipe and fittings with thermal insulation shall be prohibited. Failure to follow these instructions could result in death or serious injury.

NOTICE

Follow venting manufacturer's equivalent lengths for specialty fittings.

5.1 General

- Installations shall comply with Authority having jurisdiction and in absence of such with:
 - » U.S. ANSI Z223.1 /NFPA 54 in the United States
- This boiler requires a dedicated direct vent system.
- Vent connections serving appliances vented by natural draft shall not be connected into any portion of mechanical draft systems operating under positive pressure.
- Use only manufacturer approved venting materials or venting materials primer and glue approved to: ULC S636 in Canada, or UL 1738 in the U.S.
- Materials used in the U.S. shall comply with Authority having jurisdiction and in absence of such with: ANSI/ASTM D1785, ANSI/ASTM F441, ANSI/ASTM F493.
- Vent system must have unrestricted movement through walls, ceilings and roof penetrations.
- Check for proper joint construction when joining pipe to fittings.
- If vent is penetrating ceilings and floors, openings must have means of fire stopping in joist areas and proper fire-stop spacer assemblies installed.
- Standard roof flashing methods must be used to install roof flashing.
- Frame wall and roof openings to provide support for attachment of termination assemblies.
- Support piping in accordance with pipe manufacturer's instruction and authority having jurisdiction. In absence of manufacturer's instruction use pipe hooks, pipe straps, brackets, or hangers of adequate and strength located at intervals of 3 ft (1 m) or less. Allow for expansion/contraction of pipe.
- Venting shall be supported adjacent to each joint using steel strapping or equivalent. See Figure 5-1.

- Support horizontal sections of vent pipe to prevent sags capable of accumulating condensate.
- Assemble vent materials in accordance with venting manufacturer's instructions.
- Slope exhaust pipe minimum of 1/4" per foot, or vent manufacturer's recommendation, whichever is greater; back toward the boiler.
- Any "in line" elbows in flue system must be taken into consideration. First elbow on the top of the boiler is included in equivalent length calculations.
- Use U.V. stabilized polypropylene when it will be exposed to sunlight, wind, or prone to freeze ups.
- Manufacturer requires use of an approved mechanical fastener, which may vary per vent pipe manufacturer, at every push-fit gasket connection when using a single wall polypropylene vent system.

5.2 Removal of Existing Boiler From Common Vent System

When existing boiler is removed from common venting system, common venting system is likely to be too large for proper venting of appliances remaining connected to it.

After removal of existing boiler, following steps shall be followed with each appliance remaining connected to common venting system placed in operation, while other appliances remaining connected to common venting system are not in operation:

- Seal any unused openings in common venting system.
- Visually inspect venting system for proper size and horizontal pitch. Determine there is no blockage or restrictions, leakage, corrosion and other deficiencies which could cause an unsafe condition.
- When practical, close all building doors, windows, and all doors between space in which appliances remaining connected to common venting system are located and other spaces of building. Turn on clothes dryer and any appliance not connected to common venting system. Turn on exhaust fans, such as range hoods and bathroom exhaust so they will operate at maximum speed. Do not operate summer exhaust fan. Close fireplace dampers.
- Turn on appliance being inspected. Follow lighting instructions. Adjust thermostat so appliances will operate continuously.
- Test for spillage at draft hood relief opening after 5 minutes of main burner operation. Use flame of match or candle, smoke from cigarette, cigar or pipe.
- Determine each appliance remaining connected to common venting system properly vents when tested as outlined above. Then return doors, windows, exhaust fans and any other gas-burning appliance to their previous condition of use.
- Any improper operation of common venting system should be corrected so installation conforms with National Fuel Code, ANSI Z223.1/NFPA 54 and/or Natural Gas and Propane Installation Code, CAN/CSA B149.1. When re-sizing any portion of common venting system, common venting system should be re-sized to approach minimum size as determined using appropriate tables in Chapter 13 of the National Fuel Gas Code, ANSI Z223.1/NFPA 54 and/or Natural Gas and Propane Installation Code, CAN/CSA B149.1.

Figure 5-1 - Venting Support

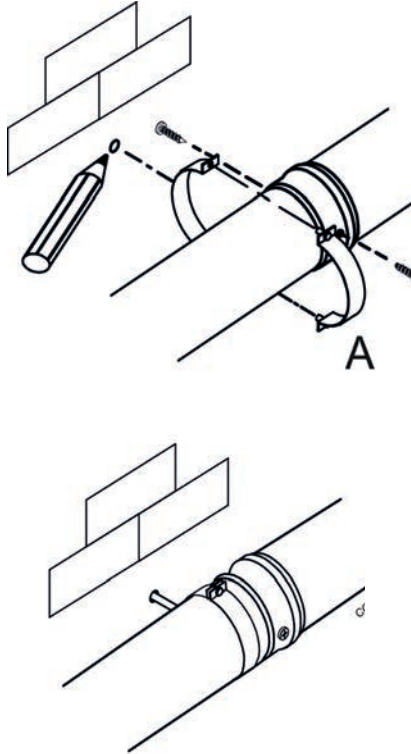

5.3 Definitions

1. **Coaxial piping** – Exhaust and air intake pipe have a common axis.
2. **Twin Pipe** – Exhaust and intake air are separate pipes,

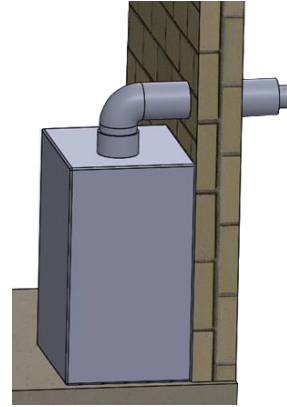

can be terminated using single wall terminals from the vent manufacturer or field built configuration using elbows or tees.

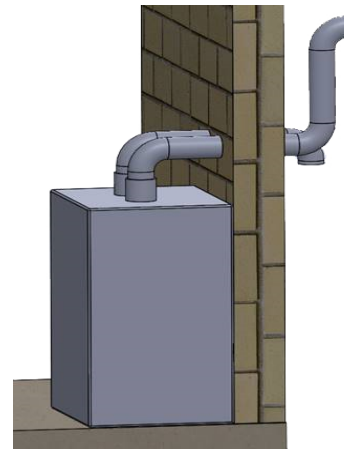

5 - COMBUSTION AIR AND VENT PIPING

5.4 Approved Venting Materials

⚠ WARNING

Manufacturer recommends this condensing boiler be vented with approved polypropylene venting material. Use only materials listed below for vent pipe, intake air pipe, and fittings. Failure to comply could result in death or serious injury.

⚠ WARNING

- Covering non-metallic vent pipe and fittings with thermal insulation shall be prohibited.
- Use of cellular core PVC for venting flue gas could result in death, or serious injury.
- Coaxial venting shall be fastened with screws. Dual flue venting is NOT fastened with screws.

⚠ WARNING

Do not use cellular core pipe. Only specified sized pipes are to be used. When using venting material other than boiler manufacturer's venting, note the correct installation procedure. Failure to follow these instructions could result in death, or serious injury.

Installation shall conform to requirements of authority having jurisdiction or in absence of such requirements:

- USA - National Fuel Gas Code, ANSI Z223.1/NFPA 54.
1. Venting shall be properly supported.
 2. Boiler shall not support any type of vent system.

3. All piping, glue, solvents, cleaners, fittings and components must conform to ASTM and ANSI standards. In Canada ULC S636 and in the USA UL 1738 schedule 40 CPVC are the only approved vent system to be used as an alternative to polypropylene venting for the exhaust pipe.
4. Manufacturer requires use of a mechanical fastener at every push-fit gasket connection when using a single wall polypropylene vent system.

Approved Polypropylene Manufacturers

* Natalini

5.5 Vent Termination

- Terminate combustion air and vent pipes with fittings or coaxial vent kit.

Use horizontal pipe for vent and 90° elbow for combustion air termination when using fittings.

- Separate vent terminal from air inlet terminal to prevent flue gas recirculation. If T-Terminal is used on flue pipe at sidewall, air inlet terminal shall be at least 36" or more away from vent terminal.
- Locate combustion air termination as far as possible from swimming pool, swimming pool pump house, and other sources of airborne chlorine.
- Locate combustion air and vent terminals as required by authority having jurisdiction.

* DuraVent®

* Centrotherm

* Z-Flex®

Note: Maximum equivalent length may vary between manufacturers.

Vent Material Options	
125 & 150	
1	4" / 2" [100 mm / 50 mm] polypropylene coaxial.
2	3" [80 mm] polypropylene twin pipe. Shall be polypropylene on BOTH intake and exhaust.
3	2" [50 mm] polypropylene twin pipe. Shall be polypropylene on BOTH intake and exhaust.
4	3" [80 mm] flexible polypropylene for chimney exhaust vent, shall have rigid 3" [80 mm] polypropylene on air intake.
5	3" [80 mm] Twin pipe CPVC. PVC optional on intake ONLY.
* Note: Adapters and fittings used with all vent systems shall be from same manufacturer and compatible with the vent pipe. See list for approved Manufacturers.	

5.6 Coaxial Venting Instructions

Maximum equivalent flue lengths for Coaxial venting are:

Coaxial Pipe Vent Lengths (Includes first elbow and termination)		
Boiler Size	125/150	
Vent Size	4"/2" [100 mm/50 mm]	
	Maximum	Minimum
Natalini	32.80 ft [10 m]	6 ft [1.8m]
DuraVent®	27.88 ft [8.5 m]	
Centrotherm	24.60 ft [7.5 m]	

Coaxial Elbows - Equivalent length	
4"/2" [100 mm/60 mm]	
45°	1.64 ft. [0.5 m]
90°	3.28 ft. [1.0 m]
Coaxial Termination - Equivalent length 3 ft (0.9 m)	

NOTE: Coaxial venting can run horizontal or vertical.

- Connect flue elbow to top of boiler and adjust direction of elbow to desired orientation (rear, right or left).
- Measure distance from outside wall face to elbow, this dimension will be known as 'X', add distance "Y" + 2" (50 mm) to "X" this is the total dimension of the vents. See Figure 5-4.
- Mark dimension from above on outer aluminum intake vent. Measure length of waste material, and transfer dimension to inner grey flue pipe.
- Remove waste from both vents (flue and air). Verify cut ends are square and free from burrs. Insert flue back into intake air vent and pass them through hole in wall.
- Check all measurements before cutting. Clearance to combustible materials is zero when using coaxial vent system.
- After installing venting use calibrated analyzer to verify there is no recirculation of combustion.
- Ensure termination is positioned with slots at the bottom.

Figure 5-2 - Coaxial Screw Placement

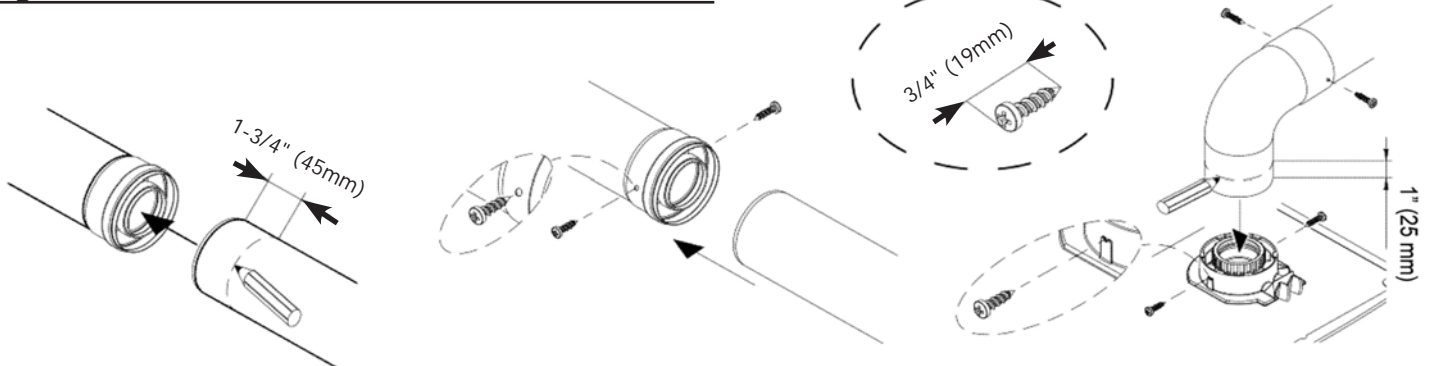

WARNING

Asphyxiation hazard. Before securing the screws ensure the pipe has been pushed in a minimum of 1-3/4" (45 mm) into the gasket end of the other pipe. Failure to follow these instructions could result in death or serious injury.

FIGURE 5-3 - Coaxial Venting Horizontal or Vertical CAN BE USED ON ALL SIZES

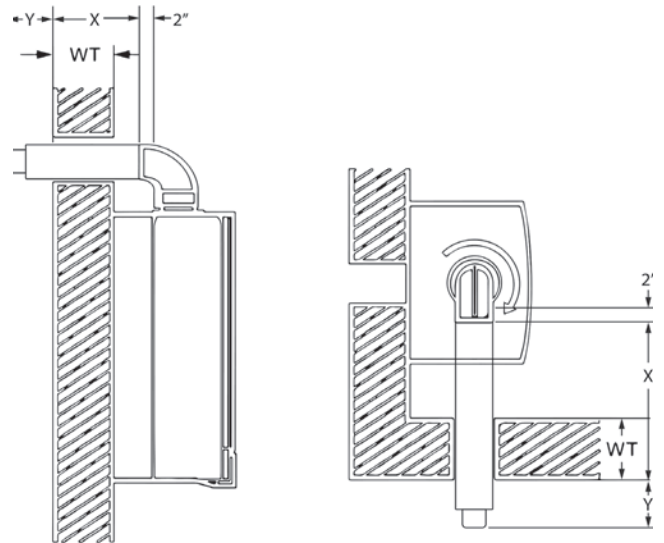

WT = Wall Thickness

(2" is insertion depth of straight pipe to elbow)

5.7 Coaxial Vent Screw Placement - See Figure 5-2

Two (2) screws shall be fastened through the outer intake pipe behind the gaskets at equal distances, approximately 180° apart. Note the screws used must be no larger than No. 8-3/4 sheet metal screws and must be zinc coated.

5 - COMBUSTION AIR AND VENT PIPING

FIGURE 5-4 Roof Mount Coaxial Venting
CAN BE USED ON ALL SIZES

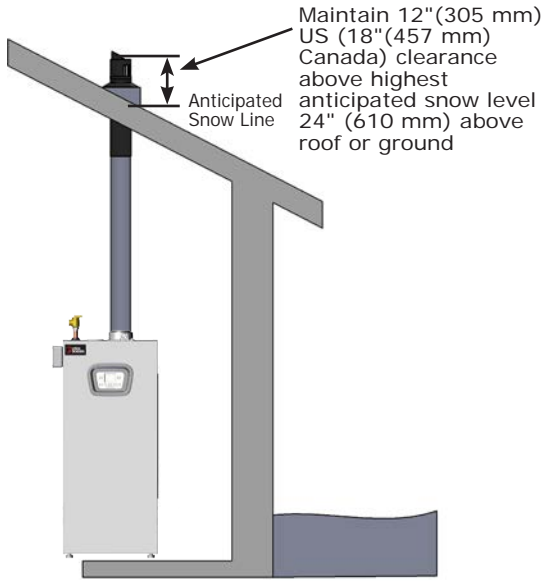

FIGURE 5-6 Side Wall Coaxial Venting
CAN BE USED ON ALL SIZES

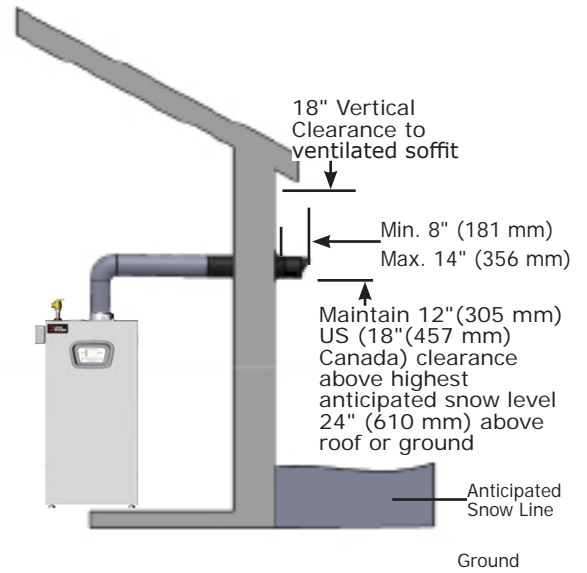

FIGURE 5-5 - Coaxial Vertical Exhaust - *Multiple Appliances*
CAN BE USED ON ALL SIZES

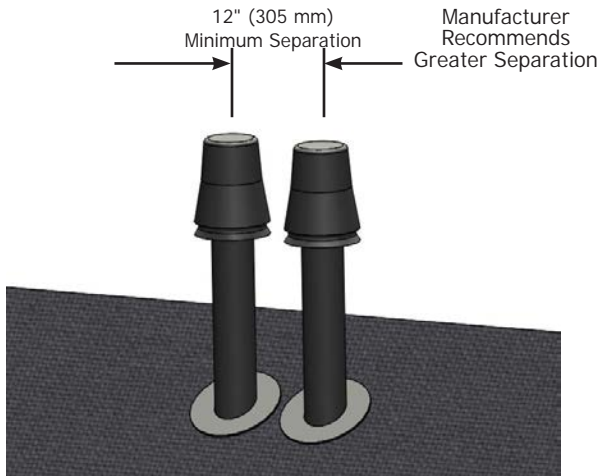
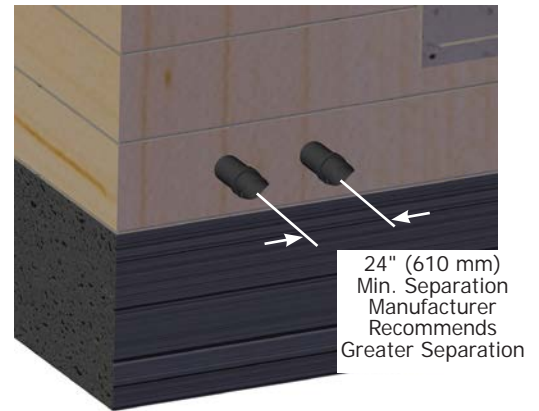

FIGURE 5-7 - Coaxial Horizontal Exhaust - *Multiple Appliances*
CAN BE USED ON ALL SIZES



⚠ WARNING

Asphyxiation hazard! Improper installation could result in death or serious injury. Read Twin Pipe Installation Instructions completely and understand all requirements before beginning installation.

5.8 Twin Pipe Systems

Twin pipe venting allows exhaust flue and intake flue to be separated from each other. Fresh air is drawn in at a different area from the flue terminal location.

A. Twin Pipe CPVC System

CPVC is approved for boiler exhaust. CPVC or PVC are both approved for air intake.

To transition from Coaxial at the top of the boiler to Twin Pipe CPVC/PVC, adapter kit is available.

B. Twin Pipe Polypropylene System

Single wall polypropylene is used for both exhaust and air intake piping.

To transition from Coaxial at the top of the boiler to Twin Pipe polypropylene venting an adapter kit is available.

C. Twin Pipe Separated Flue

Exhaust and combustion air intake are not located in same general location.

D. Twin Pipe - Common Atmospheric Zone Termination

Exhaust and combustion air intake are located in same general location and are of equal length.

Twin Pipe Vent Lengths (Includes first elbow and termination)				
Boiler Size		125/150		
Vent Size		3" [80 mm]	2" [50 mm]	All
		Maximum		Minimum
Intake Vent	L1	49 ft [15m]	85 ft	6 ft
Exhaust Vent	L2	147 ft [45 m]	[25.9 m]	[1.8 m]
Combined Vent	L1+L2	196 ft [60 m]	170 ft	12 ft.
			[51.8 m]	[3.6m]

Single Wall Elbows - Equivalent Length

	3"	2"
45° bend	0.82 ft [0.25 m]	3 ft [0.91 m]
90° bend	1.64 ft [0.50 m]	5 ft [1.5 m]

NOTE: Two pipe can be installed horizontally or vertically.

FIGURE 5-8 - 3" / 80 mm Twin Pipe Separated Horizontal Flue Termination

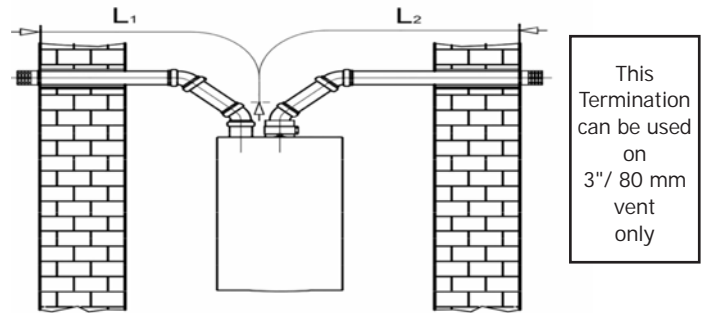

FIGURE 5-9 - 3" / 80 mm Twin Pipe Separated Horizontal Flue Termination -

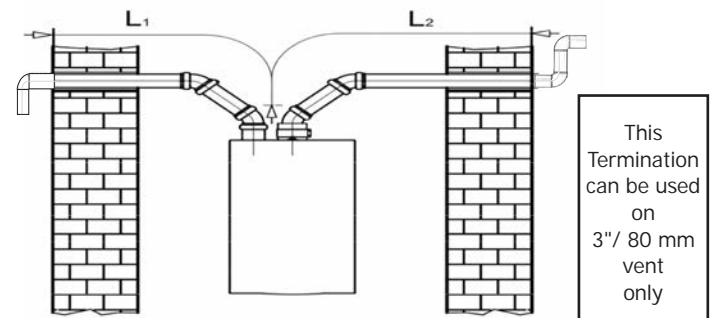
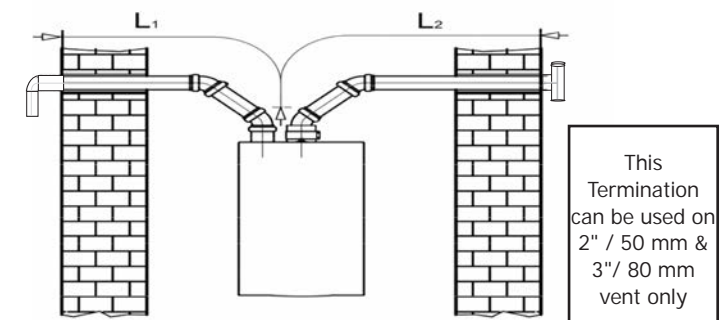

FIGURE 5-10 - 2" / 50 mm & 3" / 80 mm Twin Pipe Separated Horizontal Flue Termination With Tee On Exhaust CAN BE USED ON ALL SIZES



Grade, Snow & Ice

Maintain 12" (305 mm) US, 18" (457 mm) Canada clearance above highest anticipated snow level, 24" (610 mm) above roof.

Avoid locations where snow may drift and block vent and combustion air. Ice or snow may cause boiler to shut down if vent or combustion air becomes obstructed.

⚠ WARNING

Asphyxiation hazard! Improper installation could result in death or serious injury. Read Twin Pipe Installation Instructions completely and understand all requirements before beginning installation.

NOTICE

Venting manufacturer's use a device to secure single wall twin pipe polypropylene vent pieces to each other. Proper application of the securing mechanism is necessary for any use of twin pipe polypropylene venting on exhaust or air intake. Securing mechanism is for indoor use only and should not be used in outdoor applications. Follow venting manufacturer's instructions for applying the securing mechanism on twin pipe polypropylene venting.

Figure 5-11 - Natalini Clamp



5.9 Securing Twin Pipe Polypropylene Venting

Example for Natalini venting system.

(For other venting system suppliers see their instructions.)

1. Place clamp so etched "UP" is facing up.
2. Open clamp slightly by separating circular areas from each other.
3. Slide male end of first pipe through open clamp so the shoulder of the female end of the pipe stops the clamp from sliding off the pipe.
4. Insert the male end of the second pipe into the clamp on the "up" etched side. Force the two pipes together.
5. Verify the two pipes are secure together with clamp in place.

5 - COMBUSTION AIR AND VENT PIPING

Roof Terminations	<ul style="list-style-type: none"> • 12" (305 mm) Min. horizontal separation between combustion air intake and vent of same appliance. • 12" (305 mm) Min. 84" (2.2 m) Max. vertical separation between combustion air intake and vent of different appliances. • 15" (381 mm) Max. horizontal length of vent. • Min. vent/intake between different appliances 12" (305 mm). • Max. allowable total vertical vent length with outside exposure is 10 ft. (3.05 m). • Abandoned unused masonry chimney may be used as chaseway for combustion air and vent. Both combustion air and vent pipe must exit above top of chimney with clearances as shown in Figure 5-14.
--------------------------	--

FIGURE 5-14 - (2" / 50 mm & 3" / 80 mm) Twin Pipe Roof Vent CAN BE USED ON ALL SIZES

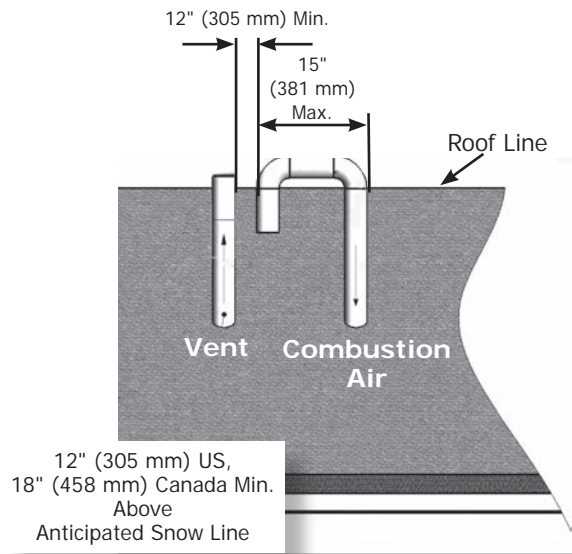

FIGURE 5-12 - Twin Pipe on Roof Combustion Air On Sidewall CAN BE USED ON ALL SIZES

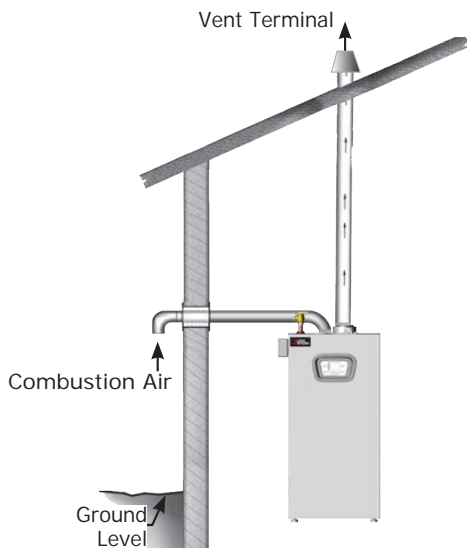

FIGURE 5-15 - (3" / 80 mm ONLY) Single Wall Exhaust Kit and Air Intake Minimum Distance Center to Center

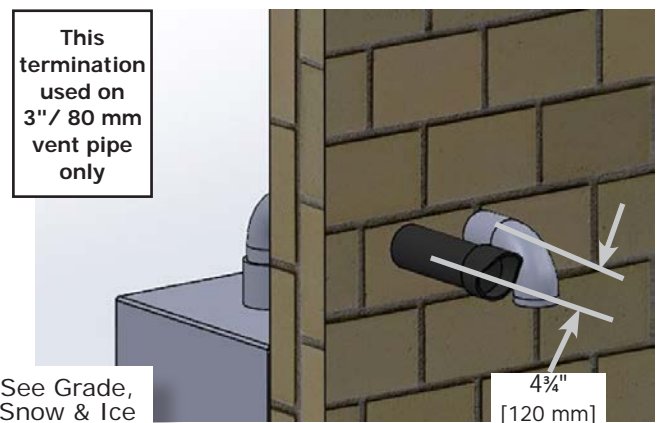

FIGURE 5-13 - Twin Pipe Flue On Sidewall, Combustion Air On Roof CAN BE USED ON ALL SIZES

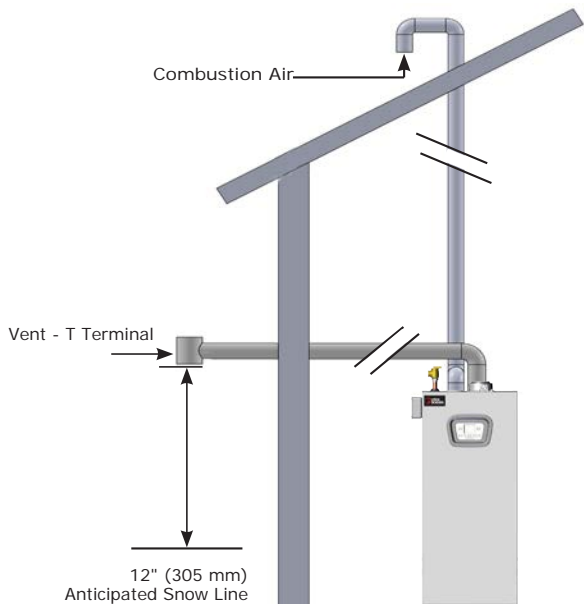
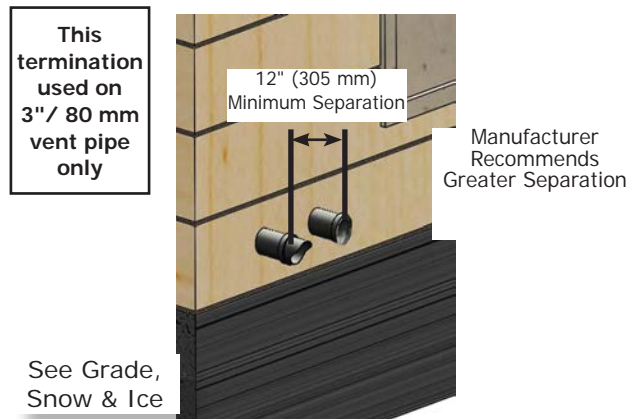

FIGURE 5-16 - (3" / 80 mm ONLY) Horizontal Twin Pipe, Exhaust and Intake



5 - COMBUSTION AIR AND VENT PIPING

FIGURE 5-17 - (3" / 80 mm ONLY) Twin Pipe Side Wall Vent (Multiple Appliances)

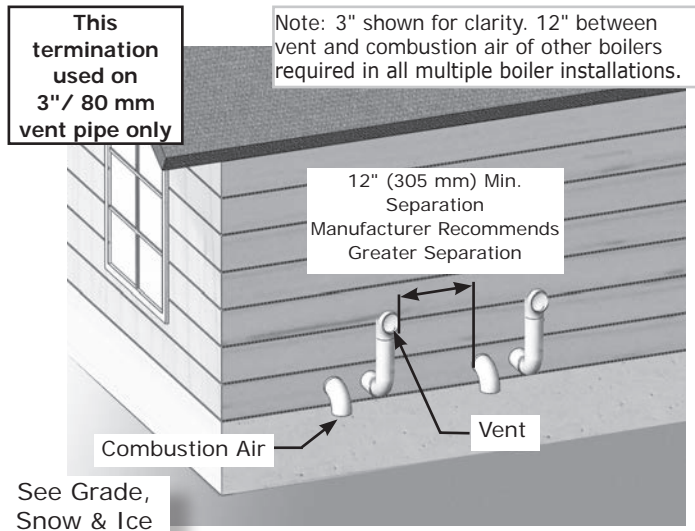

FIGURE 5-20 - 2" / 50 mm & 3" / 80 mm Vent Pipe with T CAN BE USED ON ALL SIZES

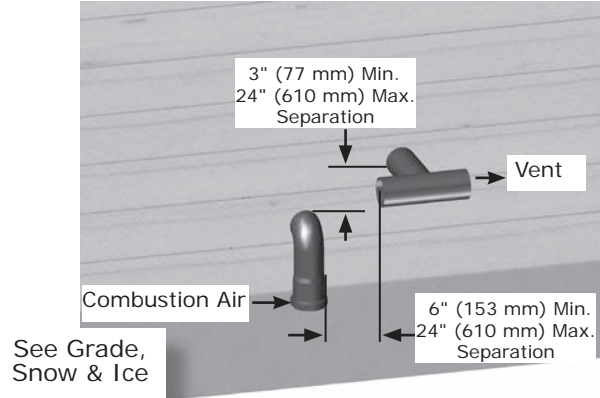

FIGURE 5-21 - 2" / 50 mm & 3" / 80 mm Vent Pipe with Tee CAN BE USED ON ALL SIZES

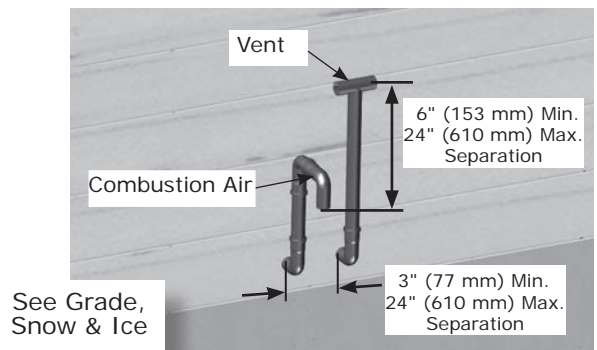

FIGURE 5-18 - (3" / 80 mm ONLY) Twin Pipe Side Wall with 45° Vent

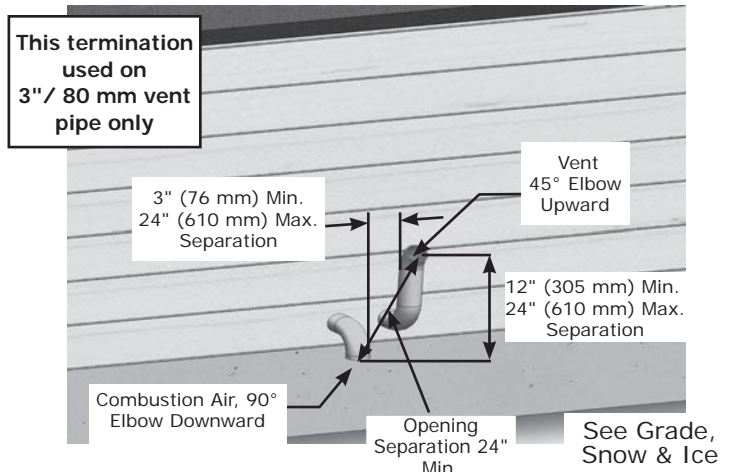

FIGURE 5-22 - 2" / 50 mm & 3" / 80 mm Twin Pipe Side Wall Vent CAN BE USED ON ALL SIZES

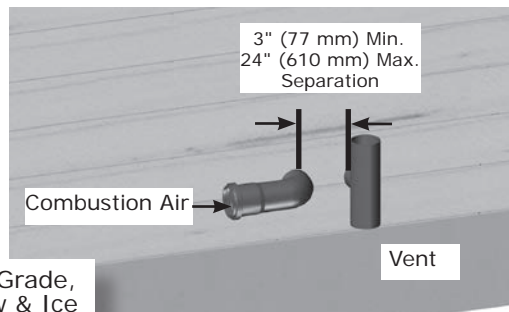

FIGURE 5-19 - (3" / 80 mm ONLY) Twin Pipe Side Wall Vent

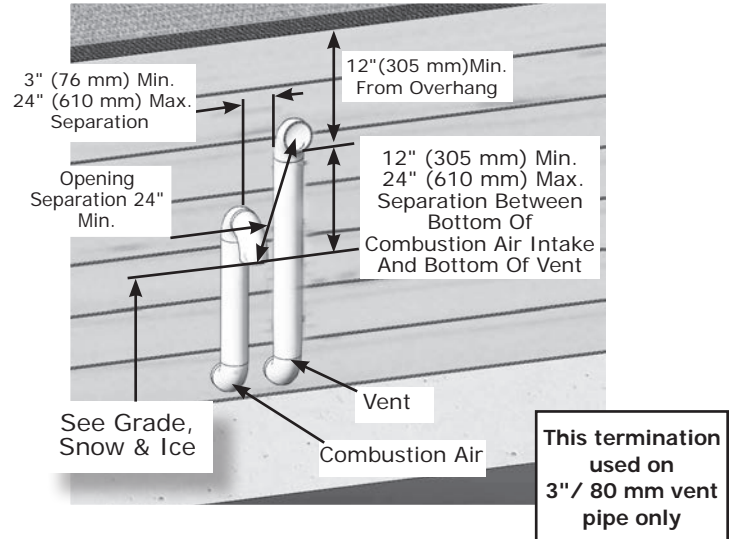
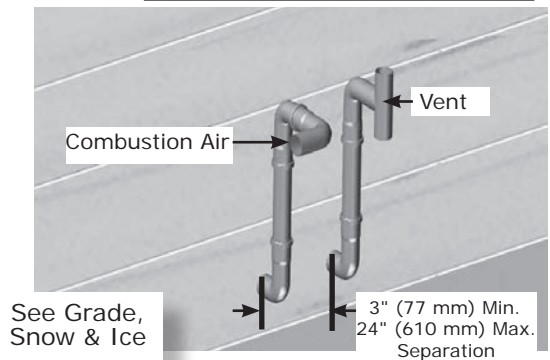

FIGURE 5-23 - 2" / 50 mm & 3" / 80 mm Twin Pipe Side Wall Vent CAN BE USED ON ALL SIZES



5 - COMBUSTION AIR AND VENT PIPING

5.10 (3" /80 mm Only) Flexible Vent System

Flexible Pipe Vent Lengths			
Boiler Size		125/150	
Vent Size		3" [80 mm] Diameter Pipe	
Minimum		Minimum	Maximum
Natalini	Exhaust	6 ft [1.8 m]	75 ft [22.8 m]
	Intake	6 ft [1.8 m]	50 ft [15.2 m]
DuraVent®	Exhaust	6 ft [1.8 m]	82 ft [24.9 m]
	Intake	6 ft [1.8 m]	50 ft [15.2 m]
Centrotherm	Exhaust	6 ft [1.8 m]	52 ft [15.8 m]
	Intake	6 ft [1.8 m]	50 ft [15.2 m]
Z-Dens	Exhaust	NA	NA
	Intake	NA	NA

Single Wall Elbows - Equivalent Length

	3" [80 mm]
45° bend	0.82 ft [0.25 m]
90° bend	1.64 ft [0.50 m]

NOTICE

Flexible vent systems shall only be run vertical. Horizontal runs before adapting to flexible must be rigid pipe.

- Maximum vent lengths based on equivalent straight runs only. Include rigid pipe and fittings in overall equivalent length calculations.
- Flexible venting installations use single wall polypropylene to pass flue gasses to base of chimney, then flexible venting to get them to termination at the top.
- Combustion air is not supplied through masonry chimney. Combustion air must be from outside using 3" [80 mm] single wall polypropylene.
- Position boiler to use minimum of rigid single wall polypropylene venting to the chimney.
- Follow venting manufacturer's instructions on assembly and clearances to maintain.
- Avoid sharp bends in flexible venting.

FIGURE 5-24 - (3" / 80 mm Only) Flexible Venting System CAN BE USED ON ALL SIZES

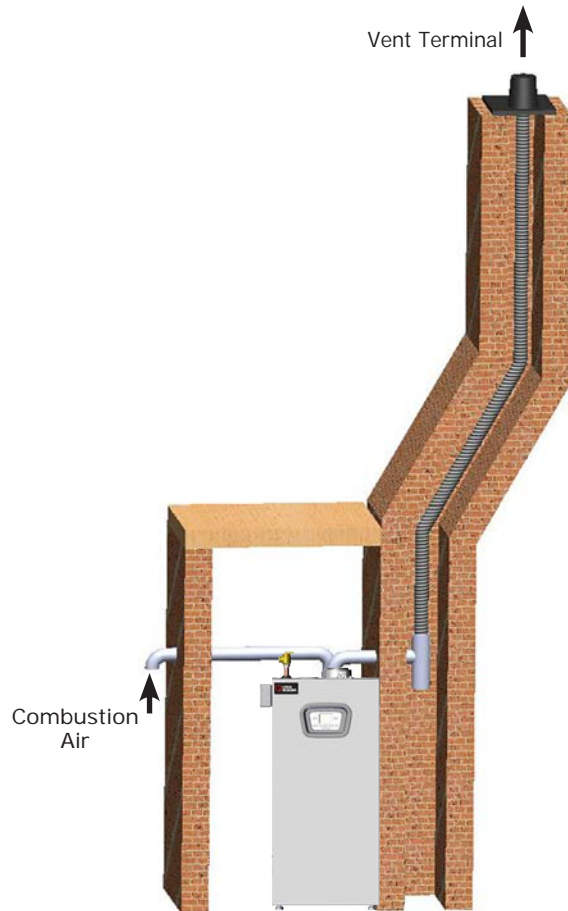

5 - COMBUSTION AIR AND VENT PIPING

FIGURE 5-25 - Flue Terminal Location

All vent pipe and combustion air pipe and fittings shall comply with the following:

Use only manufacturer approved venting materials or venting materials primer and glue approved to: ULC S636 in Canada, or UL 1738 in the U.S.

Materials used in the U.S. shall comply with Authority having jurisdiction and in absence of such with: ANSI/ASTM D1785, ANSI/ASTM F441, ANSI/ASTM F493.

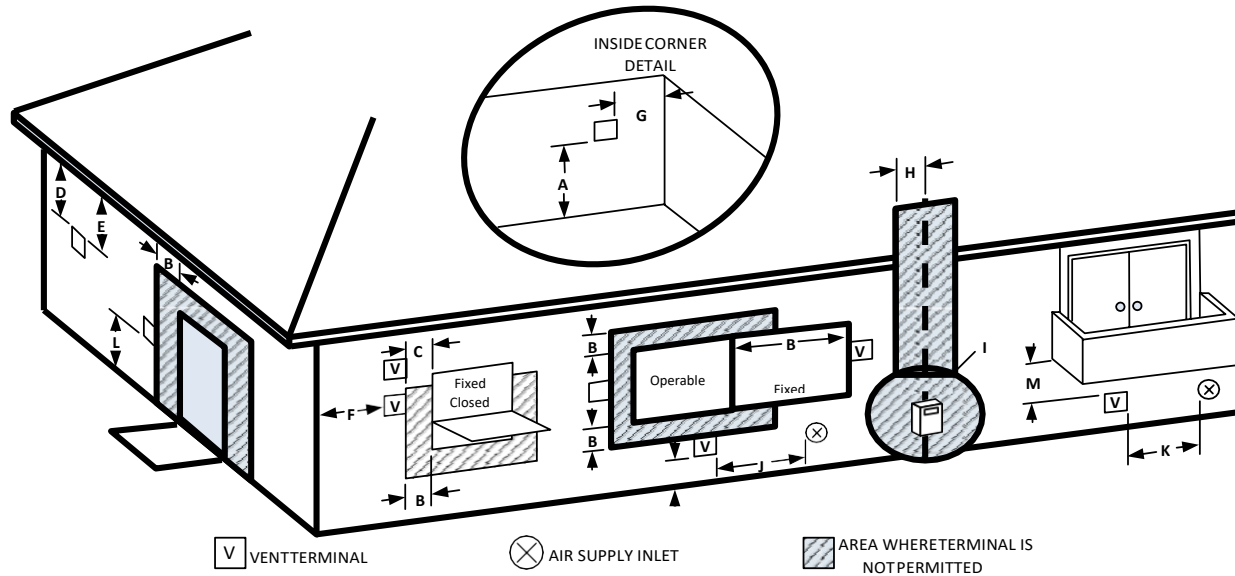

Vent Termination Minimum Clearances

		US Installations	Canadian Installations
A	Clearance above grade, veranda, porch, deck, or balcony	12" (305 mm)	12" (305 mm)
B	Clearance to window or door that may be opened	12" (305 mm)	3 ft. (0.9 m)
C	Clearance to permanently closed window	*12" (305 mm)	*12" (305 mm)
D	Vertical Clearance to ventilated soffit located above the terminal within a horizontal distance of 2 feet (610 mm) from the center line of the terminal	18" (457 mm)	18" (457 mm)
E	Clearance to unventilated soffit	18" (457 mm)	18" (457 mm)
F	Clearance to outside corner	9" (229 mm)	9" (229 mm)
G	Clearance to inside corner	36" (456 mm)	36" (456 mm)
H	Clearance to each side of center line extended above meter/ regulator assembly	3 ft. (0.9 m) within a height of 15 ft. (4.5 m) above the meter/ regulator assembly	3 ft. (0.9 m)
I	Clearance to service regulator vent outlet	3 ft. (0.9 m)	3 ft. (0.9 m)
J	Clearance to non-mechanical air supply inlet to building or the combustion air inlet to any other appliance	12" (305 mm)	3 ft. (0.9 m)
K	Clearance to mechanical air supply inlet	*3 ft. (0.9 m)	6 ft. (1.8 m)
L	Clearance above paved sidewalk or paved driveway located on public property	*7 ft. (2.1 m)	7 ft. (2.1 m) †
M	Clearance under veranda, porch, deck or balcony	*12" (305 mm) ‡	12" (305 mm) ‡
† A vent shall not terminate directly above a sidewalk or paved driveway that is located between two single family dwellings and serves both dwellings.		*For clearances not specified in ANSI Z223.1/NFPA 54 or CSA B149.1, clearance will be in accordance with local installation codes and the requirements of the gas supplier and these installation instructions.	
‡ Permitted only if veranda, porch, deck or balcony is fully open on a minimum of one side beneath the floor.			

Note: Local Codes or Regulations may require different clearances. Flue terminal must be exposed to external air and position must allow the free passage of air across it at all times. In certain weather conditions the terminal may emit a plume of steam. Avoid positioning terminal where this may cause a nuisance.

FIGURE 5-26 - Condensate Drain

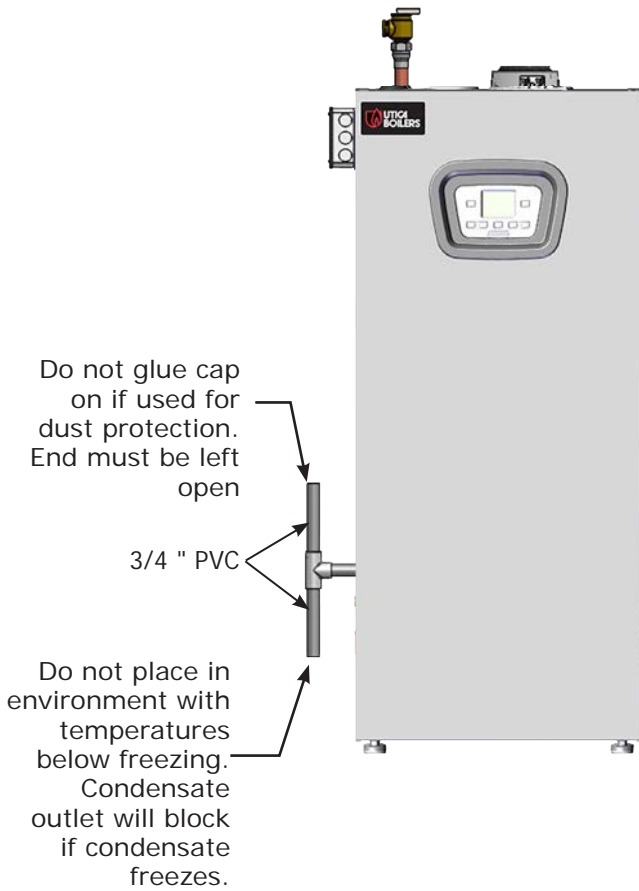

5.11 Condensate Piping

- Use materials acceptable to authority having jurisdiction. In absence of such authority:
 - USA - PVC or CPVC per ASTM D1785/D2845 Cement or primer per ASME D2564 or F493.
 -
- No external trap needed.
- Connect condensate hose, hose clamps, and coupling to boiler drain trap as shown in figure 5-28.
- Connect condensate piping to 3/4" PVC for 125/150 as shown.
- Slope condensate drain pipe minimum 1/4" per foot (21 mm/m) away from boiler.
- Support condensate pipe to eliminate any sags.
- Use field source condensate pump, designated for use with condensing boiler, if boiler located below disposal point.
- Condensate pump should have overflow switch. Condensate from Boiler is slightly acidic and may cause property damage if overflow.
- Field source condensate neutralizing kit as required by authority having jurisdiction or for environmentally friendly condensate disposal.

NOTICE

Manufacturer requires an air vent be used to prevent condensate line vacuum lock.

⚠ WARNING

- Poison hazard. Ethylene glycol is toxic. Do not use ethylene glycol.
- Never use automotive or standard glycol antifreeze, even ethylene glycol made for hydronic systems.
- Ethylene glycol can attack gaskets and seals used in hydronic systems.
- Do not use petroleum based cleaning or sealing compounds boiler system.
- Do not fill boiler or boiler system with softened water.
- Use only inhibited propylene glycol solutions certified by fluid manufacturer as acceptable for use with closed water heating system.
- Thoroughly clean and flush any system that used glycol before installing new Boiler.
- Provide user with Material Safety Data Sheet (MSDS) on fluid used.

NOTICE

Boiler rated at 50 psig (345 kPa) maximum allowable working pressure. Boiler provided with 30 psig (206 kPa) safety relief valve.

NOTICE

System pressure above 43 psi [2.96 bar] **WILL** result in boiler shutting down.

6.1 General

- Primary/Secondary piping required by manufacturer.
- Install piping in accordance with authority having jurisdiction.
- Support system piping and safety relief valve discharge piping. Boiler's internal piping can be damaged if subjected to excessive weight.

NOTICE

The intended use of the internal heat exchanger pump is a boiler loop. Do not use as a primary system pump.

- Size central heating pump (and domestic hot water pump, if used) for system requirements only. Internal heat exchanger pump compensates for pressure drop through boiler internal piping and heat exchanger.
- Thoroughly clean and flush system before connecting to boiler.
- If oil is present in system water, use approved detergent to wash system.

- It is necessary to semi-annually check the water quality of central heating systems.
- Manufacturer recommends installation of magnetic dirt separator in the hydronic system where there are cast iron or steel components, or where the previous boiler was a cast iron heat exchanger. The abrasive, extremely fine sediment is difficult to remove and can deposit onto heat exchange surfaces and accumulate in pump cavities causing reduced efficiency and premature wear.
- Flush system to remove any solid objects such as metal chips, fibers, or Teflon tape, etc.
- Flush system until water runs clean and piping is free of sediment.
- Use purge valve to flush zoned systems, each zone separately. If purge valves and isolation valves are not installed, install them to properly clean the system.
- When purging installations that include standing iron radiators and systems with manual vents at high points, start with nearest manual air vent. Open the vent until water flows out, then close vent. Repeat this procedure, working toward furthest air vent.
- Install a basket strainer if large amounts of sediment is present. Keep basket clear of sediment build up.
- Ensure piping in the heating system has an oxygen barrier.

6.2 Special Conditions

NOTICE

Do not expose boiler and condensate piping to freezing temperatures.

- System piping exposed to freezing conditions: Use inhibited propylene glycol solutions certified by fluid manufacturer for use with closed water heating system. Do not use automotive or ethylene glycol.
- Boiler installed above radiation level (or as required by authority having jurisdiction). Integral low water pressure switch is provided in boiler.
- Boiler used in connection with refrigeration system. Install piping in parallel with boiler, with appropriate valves to prevent chilled medium from entering boiler.
- System piping connected to heating coils located in air handling unit exposed to refrigerated air circulation. Install flow control valves or other automatic means to prevent gravity circulation of boiler water during cooling cycle.

⚠ WARNING

Burn and scald hazard. Safety relief valve could discharge steam or hot water during operation. Use pipe suitable for temperatures of 375°F (191°C) or greater. DO NOT use plastic pipe. Install discharge piping per these instructions.

NOTICE

When installing safety relief valve it must be installed in a vertical position with spindle at top.

6.3 Safety Relief Valve and Air Vent

- Install safety relief valve using pipe fitting provided with boiler. See Figure 6-1.
- Install safety relief valve with spindle in vertical position.
- Do not install shutoff valve between boiler and safety relief valve.
- Install discharge piping from safety relief valve. Do not use plastic pipe.
- Use ¾" or larger pipe.
- Use pipe suitable for temperatures of 375°F (191°C) or greater. Do not use plastic pipe on safety relief valve.
- Individual boiler discharge piping shall be independent of other discharge piping.
- Size and arrange discharge piping to avoid reducing safety relief valve relieving capacity below minimum relief valve capacity stated on rating plate.
- Run pipe as short and straight as possible to location protecting user from scalding and properly drain piping.
- Install union, if used, close to safety relief valve outlet.
- Install elbow(s), if used, close to safety relief valve outlet and downstream of union (if used).
- Terminate pipe with plain end (not threaded).

6.4 Trim Piping

- Temperature - Pressure Gauge. Install temperature pressure gauge in near boiler piping on supply side.
- Some boiler models may have integral drain valve located inside jacket directly underneath pump. Install external drain valve as required.

FIGURE 6-1 Safety Relief Valve

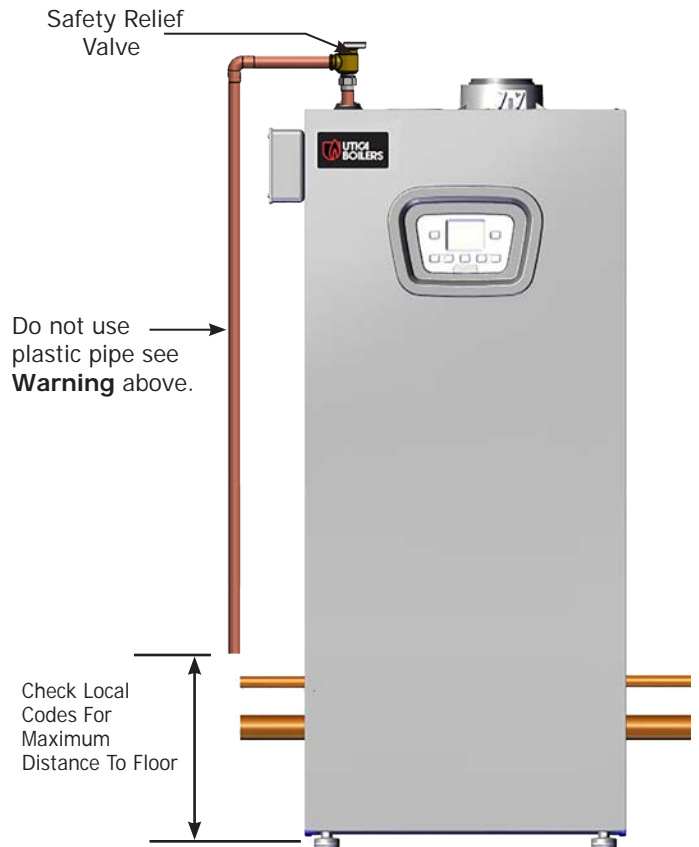

6.5 System Piping

- See Figure 6-6 for basic system piping configurations.
- Systems with automatic fill valves require back flow prevention device.
- Single boiler system. See Figures 6-5, 6-6, for general guidance. Additional considerations:
 - Boiler control only supports integrated pump. Installer responsible for integration of multiple central heating pumps using field supplied external control.
 - Boiler control allows domestic hot water prioritization.
- Thoroughly flush all hydronic piping.
- Secure all valves/fittings to boiler.
- Route pressure relief valve discharge piping to the floor. Follow local code with respect to necessary distance to the floor. See Figure 6-1.
- Verify all drain valves are closed.

FIGURE 6-2 - Piping Diagram - LWCO Location

Note → Arrange piping to prevent water dripping onto boiler.

Note → Illustrations are meant to show system piping concept only. Installer is responsible for all equipment and detailing required by authority having jurisdiction.

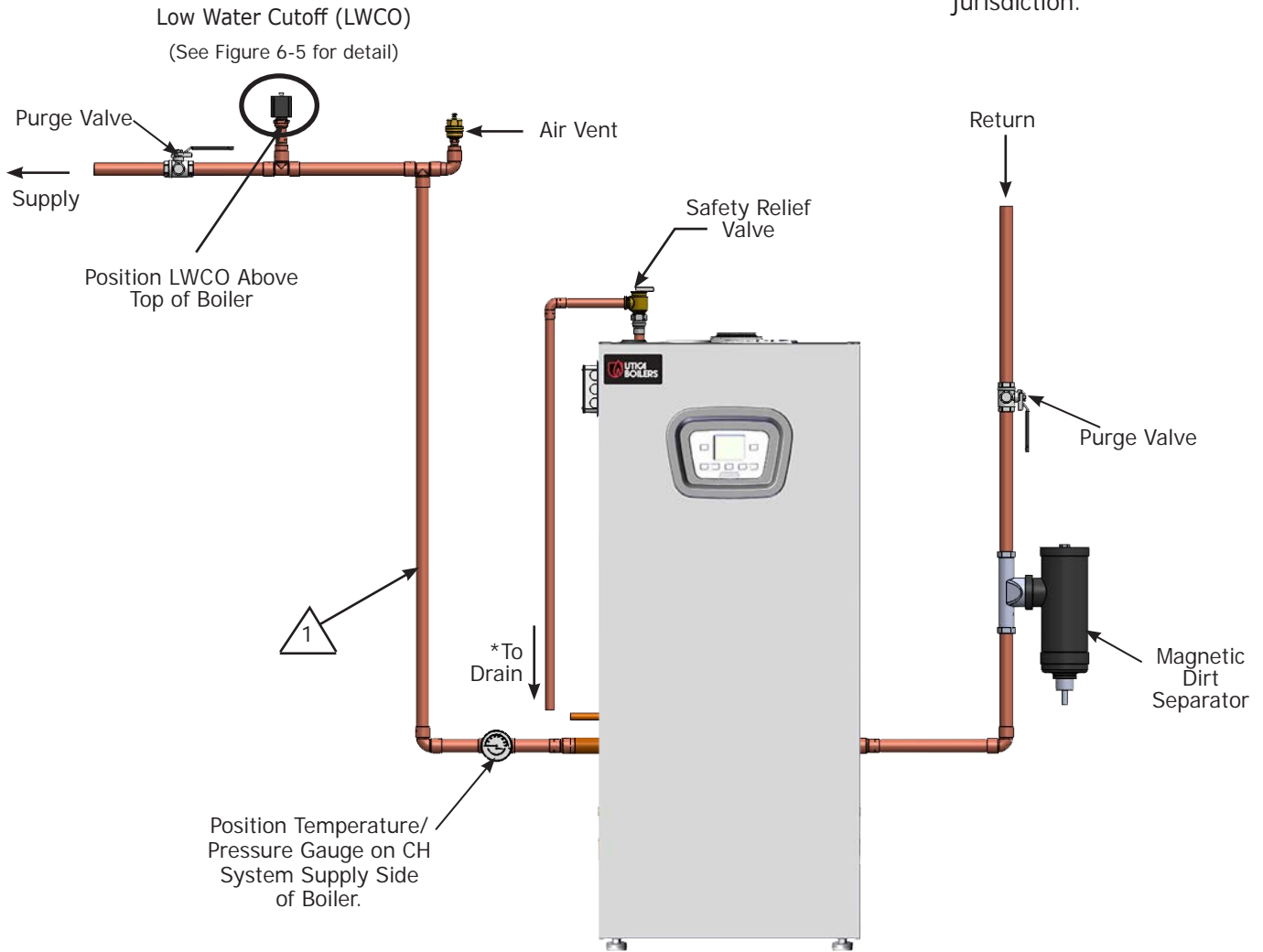

* Check Local Codes for Maximum Distance to Floor.

Note → **1** DO NOT PLACE ISOLATION VALVE BEFORE TEE OR LWCO.

6.6 External Optional Low Water Cut Off

These guidelines are supplied when necessary to install an additional Low Water Cut Off (LWCO), for sensing a low water level condition in a boiler, as required by the Authority Having Jurisdiction.

Follow LWCO manufacturer installation instructions for type of LWCO selected in addition to these instructions.

LWCO shall be 120V/60HZ control and dry contacts sized for load being connected. Wire control to boiler. See Figure 6-4.

Connect LWCO device to the system ground. Ground in accordance with the requirements of the authority having jurisdiction or, in the absence of such requirements, with the National Electrical Code (NEC) or Canadian Electrical Code CEC.

- Locate LWCO sensing device in the supply piping, above the minimum height of boiler. See Figure 6-2, Piping Diagram.
- Position control in HORIZONTAL piping to assure proper boiler protection (upright or 90° rotation).
- For proper operation, sensing element of the LWCO control shall be positioned in the tee to sense the main water stream. Maintain minimum 1/4" spacing from pipe walls. Element shall NOT contact the rear, or side walls of the tee. See Figure 6-3.
- Install an air vent using a tee to avoid nuisance shutdowns.
- Apply small amount of pipe sealant to threaded connections.
- Arrange piping to prevent water dripping onto boiler.
- DO NOT install water shutoff valve between boiler and LWCO sensing device.

FIGURE 6-3 - Low Water Cutoff - Detail

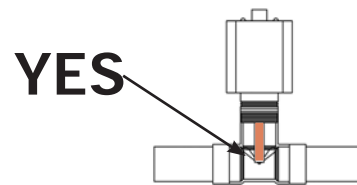
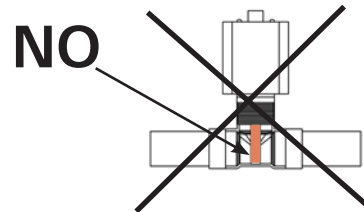
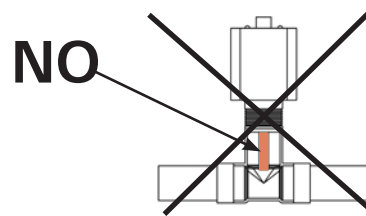
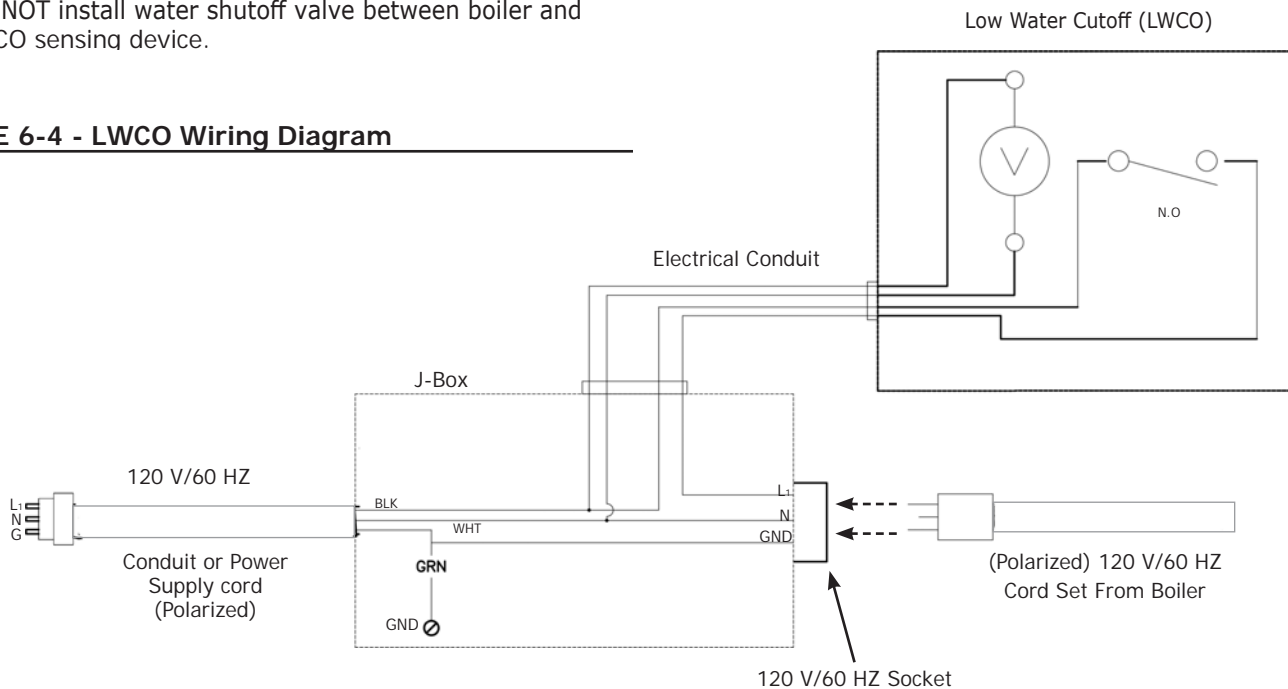
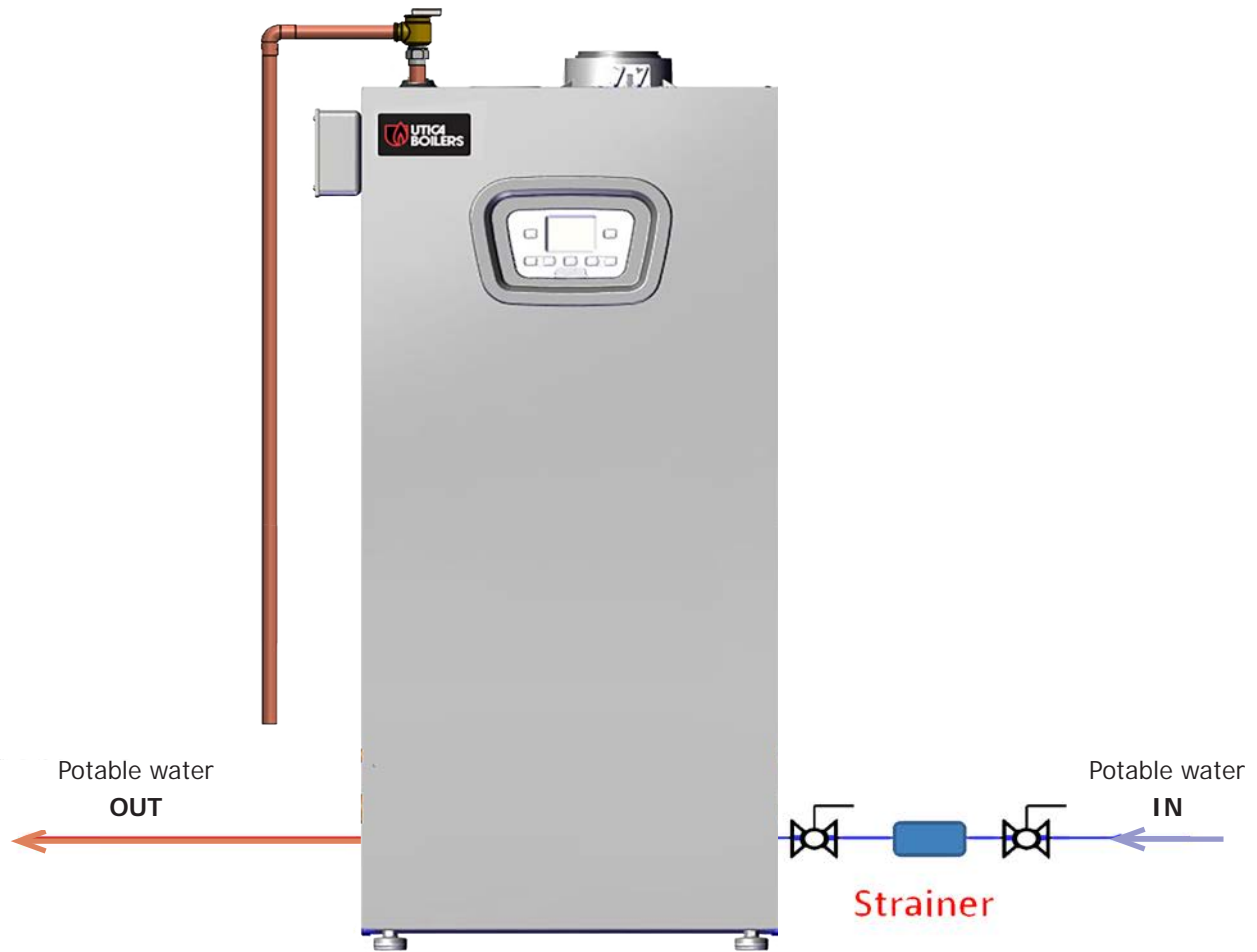

FIGURE 6-4 - LWCO Wiring Diagram



6.5 Manufacturer Recommendation - Strainer



Manufacturer Recommendation

Manufacturer strongly recommends the use of a strainer filtering potable water before entering the boiler. The strainer prevents any sedimentation and debris from your water supply piping from entering the boiler. Debris carried from the water supply will clog DHW water flow sensor, potentially resulting in significant operation issues.

Locate the strainer as close to the boiler as possible and place on DHW (domestic hot water) inlet connection located at bottom of the boiler.

6.7 Central Heating System

Boiler is designed for use in a sealed central heating system. Design the system to operate with flow temperatures of up to 176°F (80° C), take pump head, expansion tank size, mean radiator temperature, etc. into account.

Boiler is supplied with the following components: Pressure relief valve - 30.0 psi (2.1 bar). Boiler internal pressure switch will shut boiler off below 7.5 psi / 0.5 bar and above 43.5 psi / 3.0 bar.

Pressure gauge - to indicate the system pressure to be maintained.

6.8 Domestic Hot Water Mode

Utica Boiler MACF-150 and MAHF-125 with indirect tank

⚠ WARNING

Burn, Scald Hazard! Water temperature over 125°F (51°C) can cause severe burns and scalding. See User's Manual before setting water temperature. Failure to follow these instructions could result in death or serious injury.

- Priority is given to the domestic hot water supply. Demand at tap or shower will override any central heating requirement.
- Flow of water will operate the DHW flow switch which requests the 3 way valve to change position. This will allow the pump to circulate the primary water through the DHW plate heat exchanger. (MACF-150 only)

- Combustion fan will then come on and begin to run at ignition speed.
- Once the fan reaches ignition speed the control board will allow power to flow to the spark generator and gas valve creating ignition in the combustion chamber. The flame sensor will acknowledge the presence of the flame in the combustion chamber and send a signal to the control board.
- Temperature sensors will send a signal to the control board allowing the control board to increase/ decrease the speed of the fan. The combustion fan will in turn modulate the gas rate accordingly.
- When the domestic hot water demand ceases the burner will extinguish, unless there is a demand for central heating.

6.9 Frost Protection Mode

Frost protection mode is integrated into the appliance when electricity is connected to the boiler, regardless if power is "on" or "off".

If temperature falls below 41°F / 5° C boiler will fire on its minimum setting until flow temperature of 86°F / 30° C is reached.

6.10 Pump Protection

Pump will automatically operate for 1 minute in every 24 hours to prevent seizing.

FIGURE 6-6

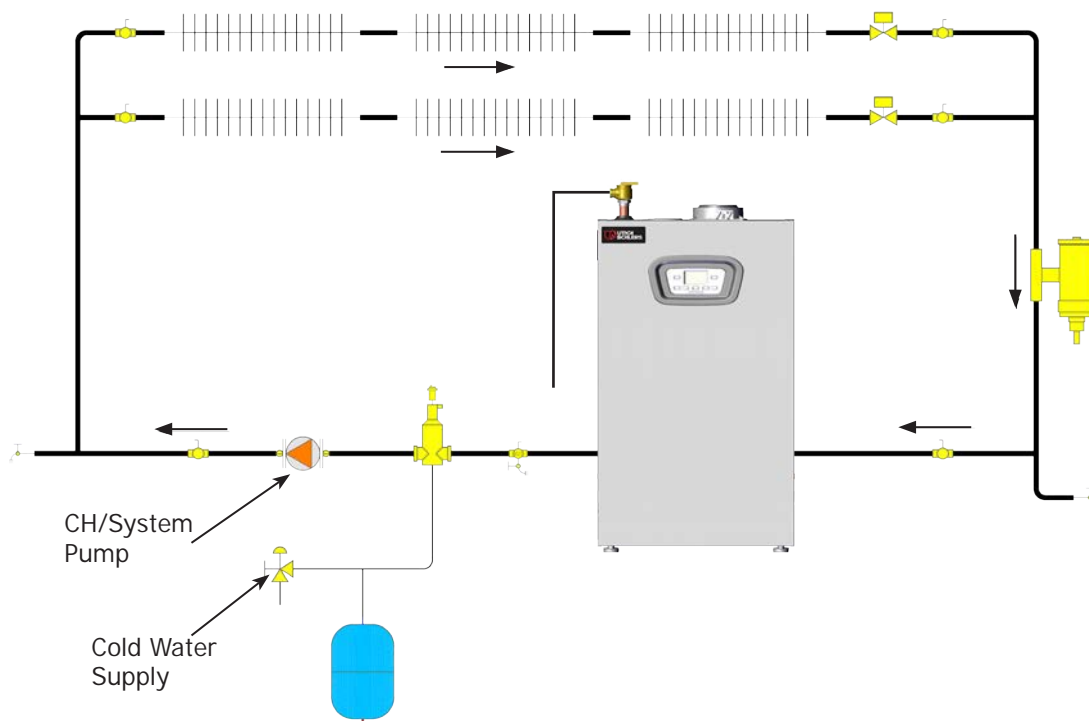

7 - GAS SUPPLY PIPING

DANGER

Fire Hazard. Do not use matches, candles, open flames, or other methods providing ignition source. Failure to comply will result in death or serious injury.

WARNING

Fire, explosion, asphyxiation and burn hazard. Boiler piping and gas connections shall be leak tested before placing boiler in operation. Failure to follow these instructions and or improper installation could result in death or serious injury.

WARNING

If overheating occurs or gas supply fails to shut off, do not turn off or disconnect the electrical supply to the pump. Shut off gas supply at a location external to the appliance.

Do not use this boiler if any part has been under water. Call a qualified service technician before use.

CAUTION

WHAT TO DO IF YOU SMELL GAS

- Do not try to light any appliance.
- Do not touch any electrical switch; do not use any phone in your building.
- Immediately call your gas supplier from a neighbor's phone. Follow gas supplier's instructions.
- If you cannot reach your gas supplier, call the fire department.

NOTICE

If overheating occurs or gas supply fails to shut off, do not turn off or disconnect electrical supply to pump. Shut off gas supply at location external to the boiler.

NOTICE

Use of CSA approved corrugated, semi-rigid stainless steel tubing with polyethylene jacketing is approved for use with boilers following tubing manufacturer's instructions.

Use of flexible "appliance whip" gas tubing is not allowed per NFPA 54.

Required Gas Supply Pressure

Natural Gas		Liquid Propane	
Min.	Max.	Min.	Max.
3.5" w.c.	10.5" w.c.	8.0" w.c.	13.0" w.c.
(0.87 kPa)	(2.61 kPa)	(1.99 kPa)	(3.23 kPa)

7.1 General

- Use piping materials and joining methods acceptable to authority having jurisdiction. In absence of such requirements:
 - USA - National Fuel Gas Code, ANSI Z223.1/NFPA 54

- Install manual main shutoff valve before the gas valve accordance with state and local requirements.
- Size and install gas piping system to provide sufficient gas supply to meet maximum input at not less than minimum supply pressure.
- Boiler and its individual shutoff valve shall be disconnected from gas supply piping system during any pressure testing of that system at test pressures in excess of 1/2 psi (3.40 kPa - 34.47 mbar).

Gas Supply Required

Model	Natural Gas (A)	Liquid Propane (E)
MAHF-125	118 ft ³ /h (3.30m ³ /h)	51 ft ³ /h (1.48m ³ /h)
MACF-150	143 ft ³ /h (4.00 m ³ /h)	61.15 ft ³ /h (1.72 m ³ /h)

- Boiler shall be isolated from the gas supply piping system by closing its individual manual shutoff valve during any pressure testing of gas supply piping system at test pressures equal to or less than 1/2 psi (3.5 kPa).
- Install boiler so that gas ignition system components are protected from water (dripping, spraying, rain, etc.) during appliance operation and service (circulator replacement, condensate trap, control replacement, etc.).
- Gas meter and supply pipes must be capable of delivering the listed quantity of gas in addition to demand from any other appliances in the house. Boiler requires a 3/4" (19.5 mm) gas supply pipe.
- Support piping with hooks straps, bands, brackets, hangers, or building structure components to prevent or dampen excessive vibrations and prevent strain on gas connection. Boiler will not support piping weight.
- Use thread (joint) compound (pipe dope) suitable for liquefied petroleum gas.
- Install external field sourced manual main gas shutoff valve, ground joint union, and sediment trap upstream of gas controls. See Figure 7-1.
- Install boiler so gas ignition system components are protected from water dripping, spraying, rain, etc. During appliance operation and service.
- Leak test boiler and gas line connections before placing boiler into operation.

NOTICE

Sediment trap shall be located upstream of gas controls.

NOTICE

If overheating occurs or gas supply fails to shut off, do not turn off or disconnect electrical supply to pump. Shut off gas supply at location external to the boiler.

7.2 Leak Check Gas Piping

Pressure test boiler and gas connection before placing boiler in operation.

- Pressure test over 1/2 psig (3.5 kPa). Disconnect boiler and its individual gas shutoff valve from gas supply system.
- Pressure test at 1/2 psig (3.5 kPa) or less. Isolate boiler from gas supply system by closing manual gas shutoff valve.
- Locate leakage using gas detector, noncorrosive detection fluid, or other leak detection method acceptable to authority having jurisdiction. Do not use matches, candles, open flames, or other methods that can provide ignition source.
- Correct leaks immediately and retest.

7.3 Gas Orifice - See Figure 7-2

Models 125, 150 - = 5.8 mm (Natural & LP)

Figure 7-1 - Gas Piping

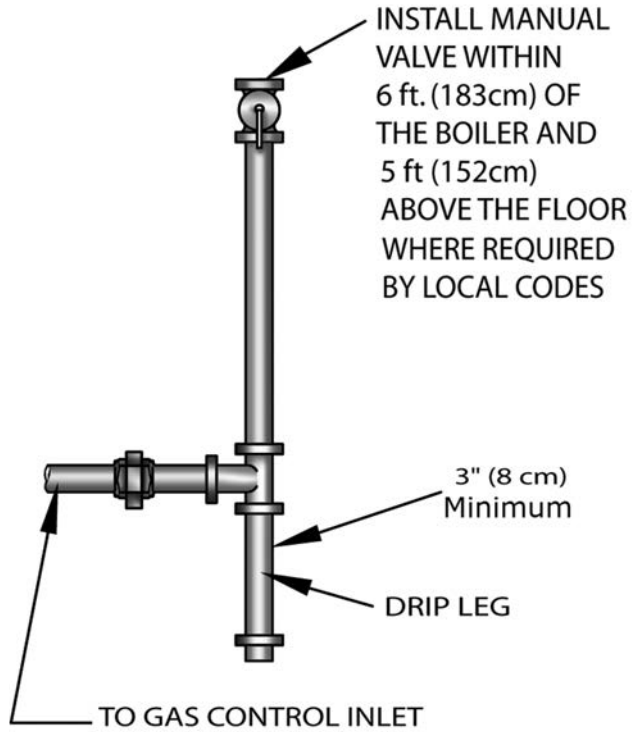
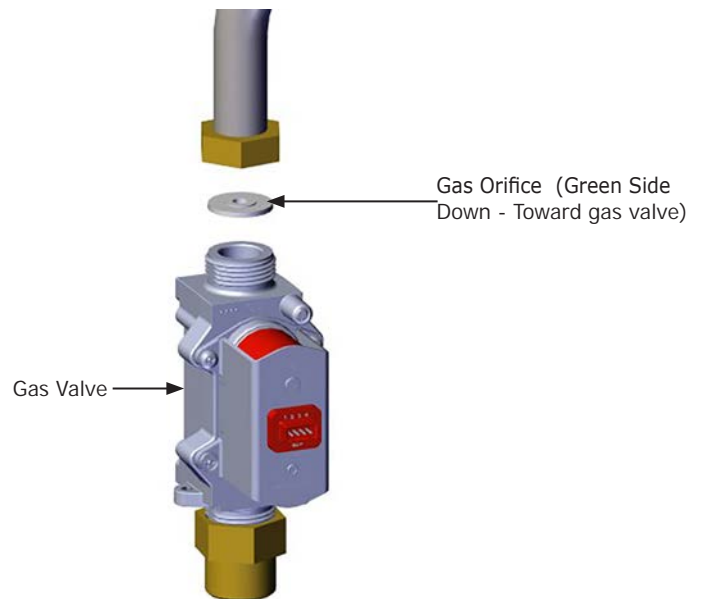

FIGURE 7-2 Gas Orifice Location



8 - ELECTRICAL CONNECTIONS

⚠ DANGER

Electrocution Hazard! HIGH VOLTAGE - Connections in terminal block M1 are high voltage (120V / 60Hz). Before making connections, verify appliance is disconnected from power supply. Respect the input polarity on terminal block M1: L (LINE) - N (NEUTRAL). Failure to follow these instructions WILL result in death or serious injury.

⚠ WARNING

Electrical shock hazard. Turn OFF electrical power supply at service panel before making electrical connections. Failure to do so could result in death or serious injury.

8.1 General

Electrically bond boiler to ground in accordance with requirements of authority having jurisdiction or in absence of such requirements refer to:

- USA- National Electrical Code, ANSI/NFPA 70.
- Install all wiring in accordance with requirements of National Electrical Code and any additional national, state, or local code requirements having jurisdiction. All wiring shall be N.E.C. Class 1.
- Boiler shall be electrically grounded in accordance with the National Electrical Code, ANSI/NFPA No. 70-latest edition.
- Boiler requires a 120V 60Hz power supply. Ensure electrical supply is polarized.
- There shall only be one common isolator, providing complete electrical isolation, for boiler and any external controls. Using PVC insulated cable 12 AWGx3C 221°F (105 °C).

8.2 Install Room Thermostat

Install room thermostat on inside wall. Do not install where it will be influenced by drafts, hot or cold water pipes, lighting fixtures, television, sun rays or near a fireplace.

8.3 Electrical Connections

- Boiler requires 120V 60Hz power supply. Verify electrical supply is polarized.
- Boiler shall be grounded and on dedicated circuit.
- Shall be one common isolator, providing electrical isolation for boiler and any external controls. Using PVC insulated cable 18 AWGx3C 221°F (105°C).
- All wiring must be installed in accordance with requirements of the National Electrical Code and any additional national, state, or local code requirements having jurisdiction. All wiring must be N.E.C. Class 1.
- Canada, installation must conform to CSA C22.1 Canadian Electrical Code Part 1 and any local codes.
- If replacing original boiler wiring use only TEW 105°C or equivalent.
- If appliance is connected to in floor system, install limit thermostat to prevent latter from overheating.

Model Size	125	150
Power Supply	120V - 60Hz	
Power Consumption	133 W	142 W
Internal Fuse (Qty. 2)	F3.15 A	
Electrode Spark Gap	1/8" to 3/16" [3.1 mm to 4.7 mm]	

Note

Wiring diagrams can be found in Appendix A of this Manual.

FIGURE 8-2 Junction Box Left side of Boiler

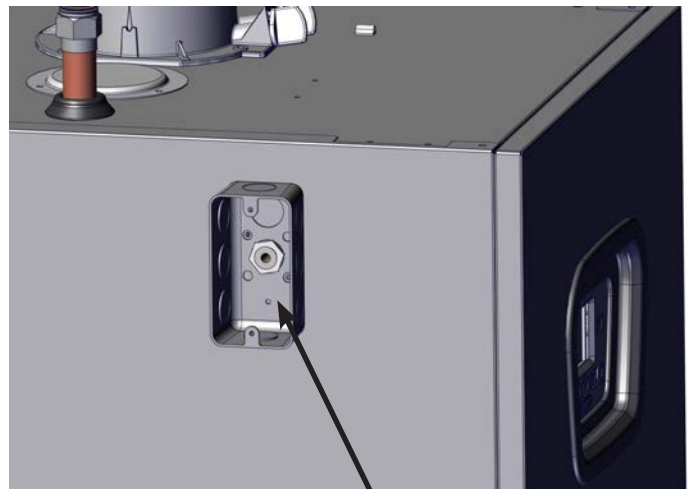

Junction Box
with Knockouts
and grommets

⚠ DANGER

Electrocution Hazard! HIGH VOLTAGE - Connections in terminal block M1 are high voltage (120V / 60Hz). Before making connections, verify appliance is disconnected from power supply. Respect the input polarity on terminal block M1: L (LINE) - N (NEUTRAL). Failure to follow these instructions WILL result in death or serious injury.

8.4 Access To Connection Block

1. Ensure there is no line voltage at boiler.
2. Lift and remove front cover. Remove screws (2) from cover on junction box located on boiler's left side. Remove junction box cover.
3. Guide controller or thermostat wire through round grommet(s) located in the junction box on boiler's left side.
4. Tilt control box forward by opening holding clip located on left side of control housing.
5. Expose M1 and M2 terminal blocks by removing screw from plastic cover on left. See Figure 8-3.
6. Remove plastic from channel in plastic cover. Run wires through new opening.
7. Connect wires to appropriate terminals on connection block.
8. Tilt control box back to original position. Ensure clip on left side of control box is fully engaged.
9. Replace front cover and cover to junction box.
10. Turn power to boiler on.

Dry contact end switches from various manufacturers can be attached to boiler control PCB.

8.5 Main Supply Connection

Main supply is connected to terminal block **M1** which is high voltage (120V / 60Hz).

Fuses, 3.15 A, are incorporated in the power supply terminal block. To check or replace fuse pull out black fuse carrier.

TERMINAL BLOCK M1

- (L) = Live (brown)
- (N) = Neutral (light blue).
- = Ground (yellow-green).
- (1) (2) = contact for 120V Room Thermostat.

Place jumper back on terminals 1-2 of boiler terminal block **M1** if room thermostat is not used or if Remote Control is not installed.

FIGURE 8-2 Terminal Block Locations

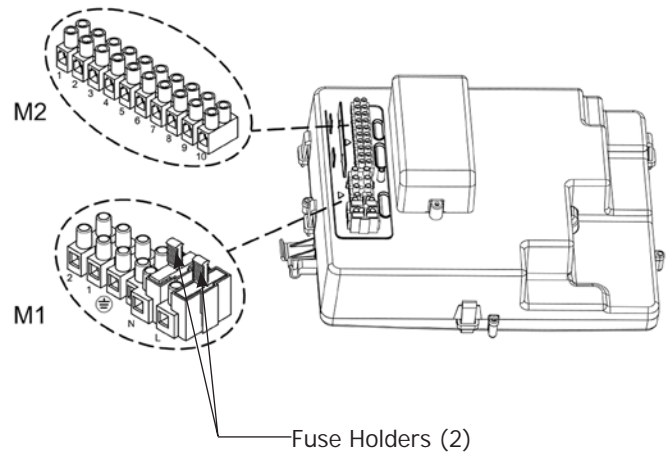
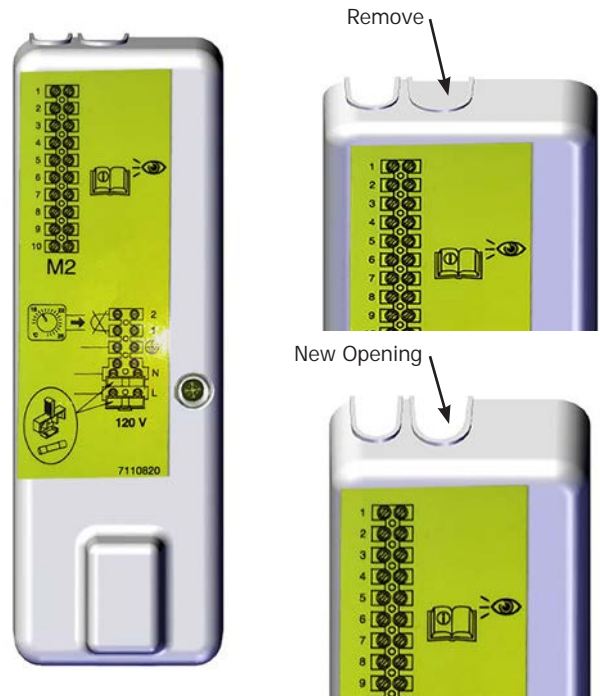

FIGURE 8-3 Terminal Plastic Cover with Knockouts



TERMINAL BLOCK M2

Terminals 1 - 2: Open Therm connection of programmable room unit (supplied as accessory)

Terminals 4 - 5: outdoor temperature sensor connection (supplied as accessory)

Terminal 3: not used.

Terminals 6 - 7 - 8: see section 8.6.

Terminals 9 - 10: Indirect storage tank connection for Utica Boiler MAHF-125.

8 - ELECTRICAL CONNECTIONS

8.6 Install Room End Switch

Install room end switch on inside wall. Do not install where it will be influenced by drafts, hot or cold water pipes, lighting fixtures, television, sun rays or near a fireplace.

Dry contact only - do not apply 24 volts between 6 and 7.

A. Connect Room End Switch

- turn power off to boiler;
- access terminal block **M2**;
- connect room end switch to terminals **6(R)-7(W)-8(C)**; Do not apply dry volt between 2 terminals. Dry contact only.
- turn boiler power on;
- verify room end switch operates per end switch manufacturer's instructions.

NOTE: maximum load allowed is 10 mA

Dry contact end switches from various manufacturers can be attached to boiler control PCB.

8.7 Optional Electrical Connections

A. 1K Ohm (1K Ω) Outdoor Temperature Sensor

To connect this accessory, see figure 8-5, terminals 4-5, and instructions supplied with **1K Ω** sensor.

B. Setting "Kt" Climate Curve

When external **1K Ω** sensor is connected to boiler, the electronic board adjusts the flow temperature calculated according to set Kt coefficient.



Select required curve by pressing   as indicated in chart below for selecting the appropriate curve (00 to 90).



FIGURE 8-6 Kt Climate Curves

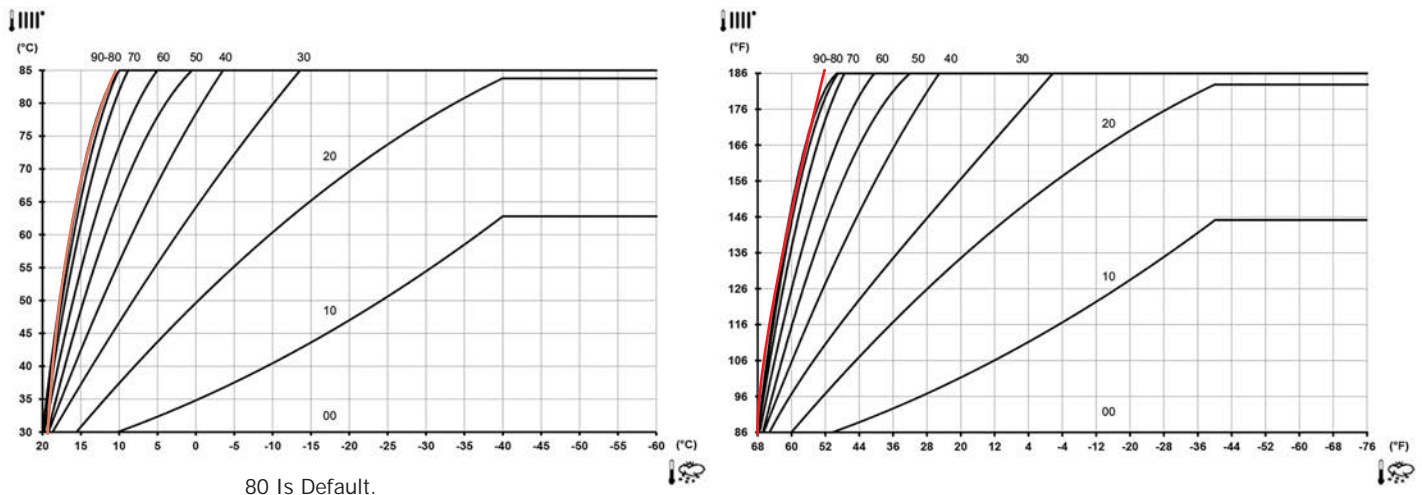

NOTE: Temperatures below -40 °F (-40 °C), maximum heating flow temperature set point no longer increases, curves shown on graph become horizontal.

Boiler setpoint will override sensor setpoint.

FIGURE 8-4 Thermostat Connections

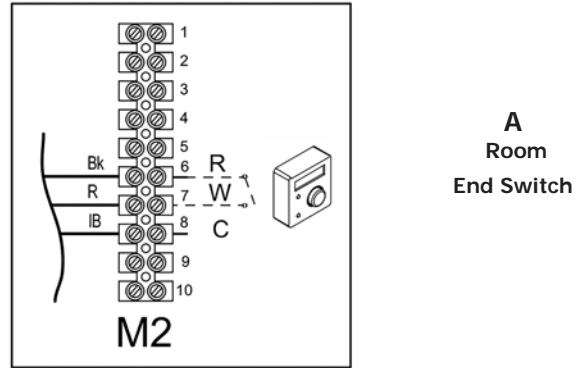
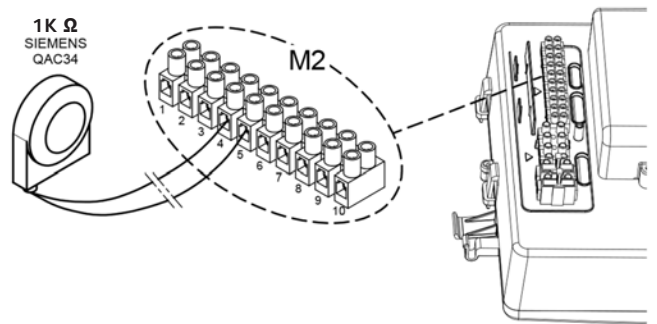

FIGURE 8-5 Outdoor Sensor Connections





NOTICE

Sensors used for this boiler are proprietary to the manufacturer. Use of after market sensors will diminish boiler performance.

8.8 Indirect Storage Tank

Boilers MAHF-125 can be electrically connected to indirect storage tank as follows:

- Connect DHW priority **10K Ω** sensor NTC to terminals **9-10** on terminal block **M2**.
- Insert **10K Ω** NTC sensor element in the sensor well of indirect storage tank.
- Verify exchange capacity of the storage boiler coil is appropriate for boiler power.
- Adjust DHW temperature +95 °F...+140 °F (+35 °C...+60 °C) by pressing   on boiler Control.

IMPORTANT: set parameter **P03 = 05** as described in: "PARAMETER SETTINGS".

Note Sensors used for this boiler are proprietary to the manufacturer. Use of after market sensors will diminish boiler performance.

FIGURE 8-7A Kt Indirect Storage Tank

*125 Model shown

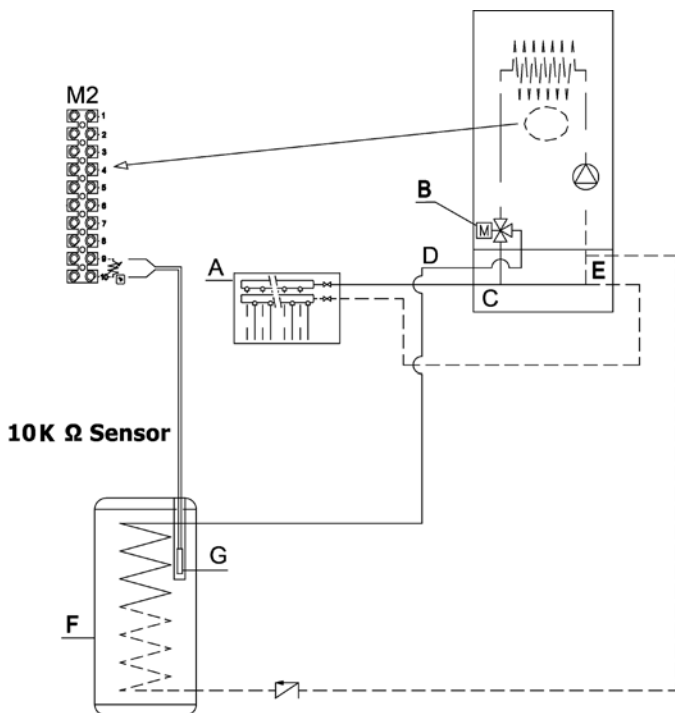

A	Heating system
B	Three way diverter valve
C	Heating water flow
D	Heating supply to DHW indirect storage tank coil
E	Heating water return
F	Tank
G	Optional 10k Ω DHW priority sensor tank

9 - START UP PROCEDURE

9.1 Central Heating System Connections - Heat Only

9.2 Central Heating System Connections - Combi

MAHF-125 HEATING ONLY WITH OPTIONAL INDIRECT DHW CONNECTION

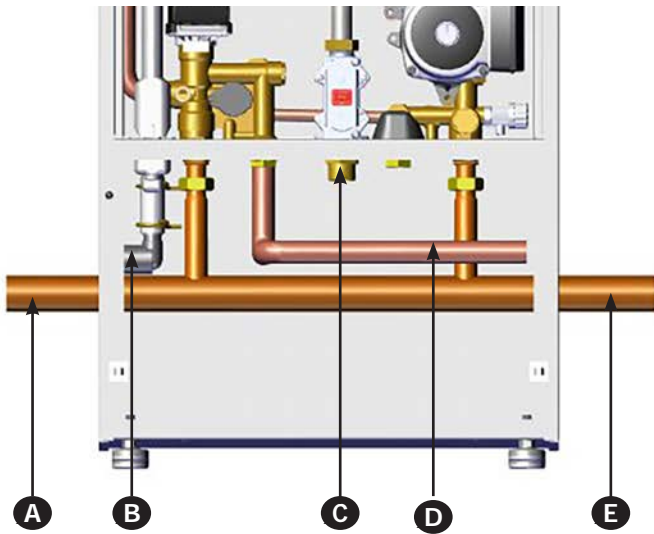

MAHF-125 HEATING ONLY WITHOUT OPTIONAL INDIRECT DHW CONNECTION

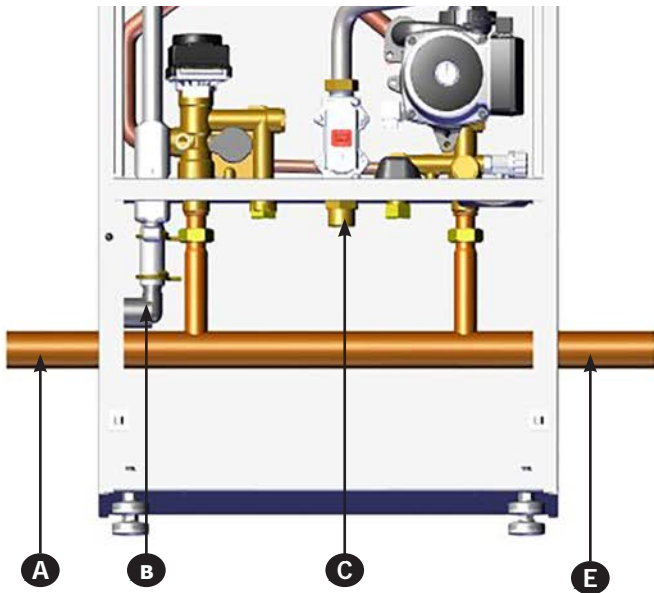

LEGEND		125
A	Heating supply connection	1 1/4" sweat
B	Drain Connection for condensate	3/4" NPT
C	Gas shutoff connection	3/4" NPT
D	Optional Indirect DHW connection (may exit right or left)	3/4" sweat
E	Heating return connection	1 1/4" sweat

MACF-150 COMBI

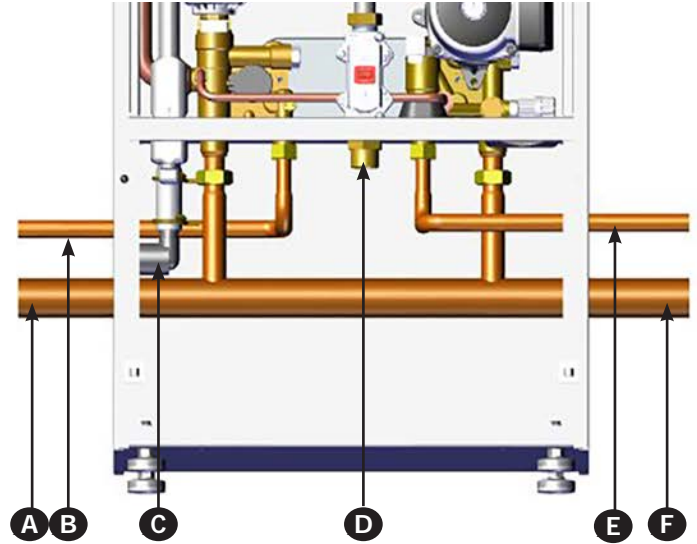

LEGEND		150
A	Heating supply connection	1 1/4" sweat
B	DHW outlet	1/2" sweat
C	Drain connection for condensate	3/4" NPT
D	Gas shutoff connection	3/4" NPT
E	Cold DHW inlet tap	1/2" sweat
F	Heating return connection	1 1/4" sweat

9.3 System Start Up

Follow all codes and regulations when filling the boiler.

Use drain taps to allow system to completely drain.

Thoroughly flush the heating system before boiler is connected and again after first heating season.

- Boiler is fitted with automatic air vent positioned on pump Vent and is fitted with adjustable sealing cap. See Figure 9-1.
- Open central heating flow and return valves. Spindle is flat in-line with valve.
- Open fill point valve on filling system until water begins to flow. To aid venting boiler drain may be open until water flows out. Close drain as soon as water appears.
- Systems using radiators to remove air - Vent each radiator in turn, starting with lowest in the system.
- It is important the pump is properly vented to avoid running it dry and damaging its bearings. Unscrew and remove cap from center of pump. Use screwdriver. Rotate exposed spindle about half turn, replace cap.
- Check operation of heating pressure relief valve. Pull lever on top of valve upwards lifting the seat. This will allow water to escape from system. Check water is escaping from the system.
- Open cold water supply inlet valve. Turn on all domestic hot water taps. Allow water to flow until no air is present. Turn off domestic hot water taps. See page 4- Physical Data and section 2.7 Operational Features.

FIGURE 9-1 Condensate Drain Assembly

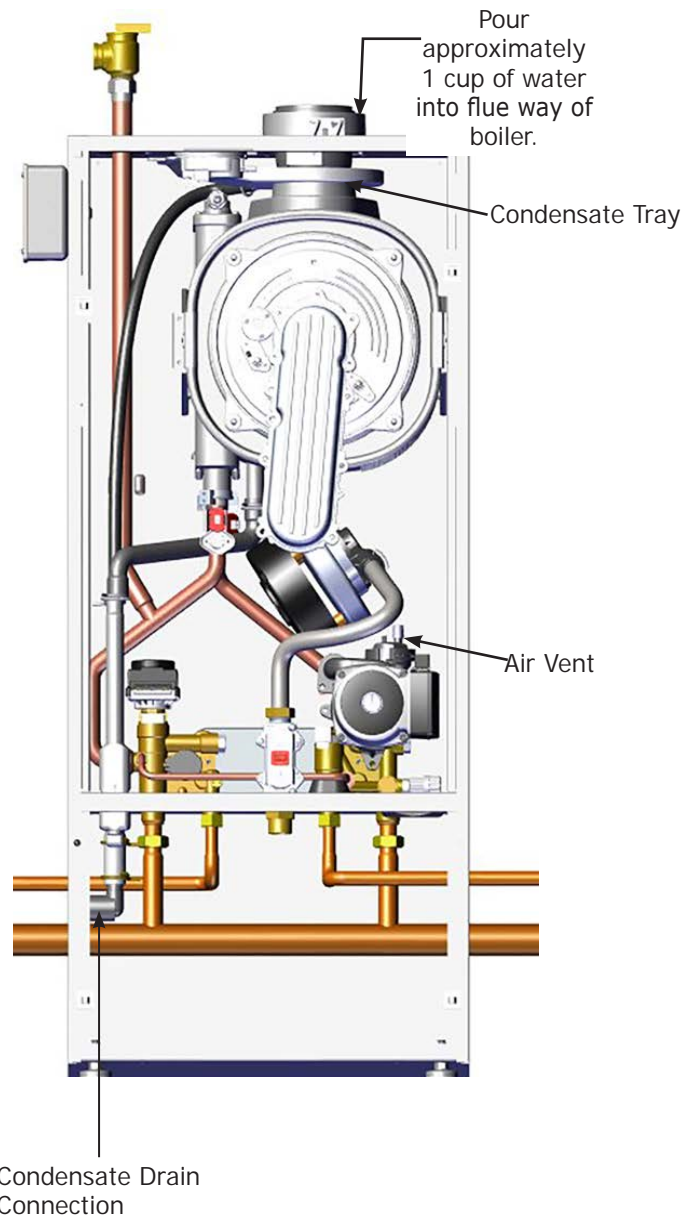

9.4 Fill Condensate Trap with Water

⚠ WARNING

Asphyxiation hazard! Fill condensate trap before starting boiler to avoid combustion products escaping boiler. Failure to follow these instructions could result in death or serious injury.

- To fill the condensate trap pour water into exhaust vent until water begins to flow through the siphon.
- Visually inspect the siphon to ensure it is full with clean water.
- During operation check condensate trap to ensure it draining properly.

Note Condensate trap must be manually filled with water at initial start up.

9.5 Control Panel

Press and hold **iIP** for 1 second, to display information as shown in the table below.

Press **⏻/R** to exit.

i	DESCRIPTION	i	DESCRIPTION
00	Secondary fault internal code	09	Setpoint Central Heating (°F/°C)
01	Heating flow temperature (°F/°C)	10/11	Manufacturing information
02	Outdoor temperature (°F/°C)	12	Flue sensor temperature (°F/°C)
03	Indirect Tank DHW temperature (boiler CH only)	13	Manufacturing information
04	Domestic hot water temperature (boiler with plate exchanger)	14	Identification Open Therm communication
05	Water pressure in heating system (PSI/bar)	15	Manufacturing information
06	Heating return temperature (°F/°C)	16	Manufacturing information
07	Thermo fuse status (000/001)	17	Fan speed ("i17"x100)
08	Not used	18	Manufacturing information

BUTTONS Key

	DHW temperature adjustment (+ to increase the temperature and - to decrease it)
	Heating water temperature adjustment (+ to increase the temperature and - to decrease it)
	Boiler operating information
	Operating mode: DHW – DHW & Heating – Heating Only
	ON/Off – Reset – Exit menu/functions



SYMBOL Key

	Off: heating and DHW disabled (only boiler frost protection is active)		Burner lit
	Ignition fault		DHW operating mode enabled
	Boiler/system water pressure low		Heating mode enabled
	Call a qualified service technician	P	Programming menu
R	Manually resettable fault ()	i	Boiler information menu
E	Fault in progress	°C, °F, bar, PSI	Set unit of measurement (SI/US)

NOTICE

All connections shall be made and water added before performing this function.







NOTICE

First ignitions immediately after installation, system will implement a self-learning procedure to reach correct ignition level.

9.6 Prior to Commissioning:

- Check system pressure is correct;
- Power boiler;
- Open gas tap (positioned under boiler);
- Select required heating mode. See section 10.4 Operating Modes.

9.7 Commissioning For The First Time:

1. Turn power to boiler on. Code "000" appears on the display. Appliance is ready for "commissioning" procedure.
2. Press   at the same time. Hold for 6 seconds. "On" appears on the display for 2 seconds followed by code "312" indicating "de-aeration" function is active. This function lasts 10 minutes.
3. Boiler will turn on after deaeration function is complete. Display will show code "000" alternating with % of ignition power and temperature value (°F / °C).
 - During this **gas recognition function** phase which lasts about 7 minutes, type of gas being used is analyzed.
 - During this function, assure maximum heat exchange to heating or DHW system (domestic hot water demand) by having all heating zones open or all domestic hot water taps open, in order to prevent boiler from switching off due to overheating.
 - If boiler operates on Gas A (Natural Gas), display shows **NG** (Natural Gas) for about 10 seconds. Boiler is now ready for normal operation.
 - If display shows **LPG** (Gas E), press  and  together and hold down for at least 4 seconds to exit without changing factory setting. Boiler will stay set to Natural Gas.
 - If boiler operates on Gas E (LPG) display shows **LPG** (Gas E). Press  for at least 6 seconds to confirm gas used.
 - If display shows **NG** (Gas A) and does not recognize the type of gas used, press  and  together and hold down for at least 4 seconds to exit the function. Change parameter **P02=01** as described in section 9.12 Parameter Settings of boiler Installation, Operation and Maintenance Manual. Perform Automatic Calibration Function. Manual Calibration may be necessary if combustion is not within specified range.



Note

Boiler must not shutoff during calibration. Open all heating zones in heating or DHW mode to ensure boiler does not shutoff.

9.8 Automatic Calibration Function







Before performing this function verify there are no heat demands in progress.

During this function ensure there is maximum heat exchange to the system in Heating or DHW mode (DHW request) to avoid boiler shutting off due to overheating.

Press  and  together and hold for about 6 seconds. When display indicates "On" press  within 3 seconds after pressing previous buttons.

NOTICE

Important: If display indicates "303" Automatic Calibration function has not been activated. Disconnect boiler from main power supply for few seconds and repeat procedure.

1. When function is enabled,  and  will flash on the display.
2. After ignition sequence, which can also take place after few attempts, boiler performs three operations. Each operation lasts about 1 minute:
 - maximum power
 - ignition power
 - minimum power
3. Before moving to the following phase, from maximum power to ignition power and then to minimum power. **P** and  appear on the display.
4. During this phase, power level reached by boiler and delivery temperature alternate on the display.
5. When ,  and  flash together on the display, automatic calibration function has completed.
6. Press  to exit the function. Display will show **ESC**.
7. Verify combustion is within specified range. If not, perform Automatic and then Manual Calibration. (See Section 9.8)

NOTICE

IMPORTANT: If Calibration function does not complete, verify unit did not shut down for over-temperature. Repeat Automatic Calibration. Replace KEY if Automatic calibration does not complete after second try.

NOTICE

During initial ignition, burner may not ignite. This may cause boiler to shut down until any air in gas pipes is vented. Repeat ignition procedure until gas reaches the burner. To reset boiler operation, press  for at least 2 seconds.

9.9 Manual Calibration Function:

Manual Calibration phase starts at the end of the Automatic Calibration.

The Display shows the boiler power and adjustment of the CO₂ value (parameter setting) during Manual Calibration sequence.

The process begins at minimum power.

- A. After Automatic Calibration sequence with flashing together on the display, you can adjust minimum power combustion by pressing to lower % CO₂, and to raise % CO₂.
- B. When minimum power combustion is in the specified range, press and then to reach ignition power.
- C. Press to adjust ignition power combustion. Press to lower % CO₂, and to raise % CO₂.
- D. When ignition power combustion is in the specified range, press and then to reach maximum power.
- E. Press to adjust maximum power combustion. Press to lower % CO₂, and to raise % CO₂.
- F. When maximum power combustion is in the specified range, press to exit Manual Calibration Function.

IMPORTANT INFORMATION

- A. If gas recognition function is interrupted by power blackout, start function again when power is restored. Press and together and hold at same time for at least 6 seconds.
- B. If display shows fault **E118** (low pressure in hydraulic circuit) during gas recognition function, open filling tap on appliance and restore correct pressure.
- C. If gas recognition function is interrupted due to fault (e.g.: **E133** no gas) press to reset. Then press and (for at least 6 seconds) to restart the function again. If gas recognition function is interrupted due to overheating, restart function by pressing and holding down together for at least 6 seconds.
- D. Combustion of this appliance has been factory controlled, calibrated and set for operation with **Gas A** (Natural Gas).
- E. During Gas Type Control Function, combustion ratio will increase for a short period of time while gas type is being established.

9.10 De-Aeration Function

Used to eliminate air inside the heating circuit when boiler is installed or after maintenance when water is drained from primary circuit.

1. Press buttons together and hold for 6 seconds. **On** appears on display for a few seconds, followed by program row **312**.
2. The electronic board will activate pump on/off cycle for 10 minutes. Function will automatically stop at end of cycle.
3. To manually exit this function, press buttons together and hold for 6 seconds.

FIGURE 9-3 - Gas Inlet Tap - Pi

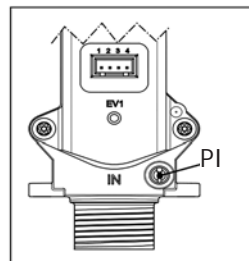

PI = Gas Supply Inlet Pressure Tap

9.11 Commission Set Up (Gas) - Changing The Type Of Gas

During the **first** installation boiler carries out an automatic commissioning function.

The system is able to detect the gas type present in the network.

Correct gas type setting, is made by pressing two buttons at the same time, see section 9.7 Commissioning.

Change of gas type is made **after** the first installation:

- Change parameter P02. See section 9.7 Commissioning and section 9.13 Parameter Settings.
- Check minimum gas pressure is suitable for selected gas:
 - Gas A (NG) = 3.5" (8.7 mbar)
 - Gas E (LPG) = 8.0" (19.9 mbar)
- Place supplied label with indication of gas type close to the data plate of boiler replacing the original.
- Perform Automatic Calibration Function - **Section 9.8**.
- Manufacturer recommends verification of CO₂ concentration on the flue.

9.12 Chimney Sweep Function (CO₂ Adjust)

For correct boiler operation, content of (CO₂ - O₂) in the combustion flue must be within tolerances indicated in table below.

COMBUSTION TABLE

		Gas A (Natural Gas) MAHF-125		Gas A (Natural Gas) MACF-150		Gas E (LPG)	
		CO ₂ %	O ₂ %	CO ₂ %	O ₂ %	CO ₂ %	O ₂ %
Maximum power (100%)	Nominal value	8.7	5.4	9.0	4.9	10.0	6.0
	Permitted value	8.2 – 9.3	6.3 – 4.3	8.5 – 9.5	5.7 – 4.0	9.5 – 10.5	6.8 – 5.2
Ignition power (*)	Nominal value	8.7	5.4	8.7	5.4	10.8	4.8
	Permitted value	8.2 – 9.3	6.3 – 4.3	8.2 – 9.3	6.3 – 4.3	10.3 – 11.3	5.5 – 4.1
Minimum power (0%)	Nominal value	8.8	5.2	8.8	5.2	10.0	6.0
	Permitted value	8.2 – 9.3	6.3 – 4.3	8.2 – 9.3	6.3 – 4.3	9.5 – 10.5	6.8 – 5.2

(*) Automatically calculated from the PCB

Chimney Sweep Function enables boiler to generate maximum heating power.

After activation, boiler power % can be adjusted from minimum (0%) to maximum (100%) in DHW mode.

- Press and hold and at the same time for 6 seconds. When the function is enabled, displays shows "On" for few seconds followed by program row "303" alternating with % of boiler power.
- Press to gradually adjust power (increments of 1%).
- To exit press both buttons together for at least 6 seconds.

If value of CO₂-O₂ is different, check the electrodes and their relative distances. See Figure 11-1.

If necessary, replace electrodes and position them correctly. If problem persists, use "COMBUSTION ADJUSTMENT FUNCTION (CO₂%)". See Section 11 General Maintenance, Figure 11-1 Electrodes. If problem persists, use [Section 9.8. Automatic Calibration Function, and Section 9.9 Manual Calibration Function.](#)

NOTICE

- Press to display instantaneous flow temperature for 15 seconds.
- Use a regularly calibrated combustion analyzer for combustion analysis.
- During normal operation boiler performs combustion control cycles. In this phase CO values higher than 400 ppm can occur for brief periods of time.

9.13 Combustion Adjustment Function (CO₂%)

This function sets out to partially adjust the value of CO₂%. Use the following procedure:

- Press buttons and together for at least 6 seconds. When the function is enabled, displays shows "On" for a few seconds followed by program row "304" alternated with the % of boiler power;

- After burner is lit, boiler reverts to maximum DHW power (100). When display shows "100" it is possible to partially adjust value of CO₂ %;
- Press and . Display shows "00" alternating with function number "304" (🔥 flashes);
- Press to raise or lower the amount of CO₂ (from -0.3% to +0.3%);
- Press to save new value. Power value "100" will show on display again. Boiler continues operating at maximum DHW power.

This procedure can be used to adjust CO₂ to ignition power and minimum power by pressing after performing step 5 above.

- After saving the new value (step 5 above), press to set boiler to ignition power. Wait for value of CO₂ to stabilize. Adjust as described in step 4 of procedure (power value is a number <> 100 and <> 0). Repeat step 5 to save.
- Press to adjust boiler to **minimum power**. Wait for value of CO₂ to stabilize. Go to step 4 to adjust (power value = 00);
- Exit function by pressing and together for at least 6 seconds, see step 1.

9.14 Check Firing Rate

- Measure input, if a gas meter is installed in the system.
 - Turn off gas to all other appliances.
 - Activate some heating zones to dissipate heat.
 - Set boiler on high fire using Chimney Sweep Function.
 - Use ½, 1 or 2 cu ft dial on gas meter. Measure time required for two or more complete revolutions. Measure time for one or more minutes.
 - Calculate input.

9 - START UP PROCEDURE

For Natural Gas :

$$\text{Input (MBH)} = \frac{3600 \times \text{___ cu ft}}{\text{___ seconds}}$$

Example: Natural Gas - Gas flow from

Meter = 2 cu ft

Measured time = 72 seconds

$$= \frac{3600 \times 2 \text{ cu ft}}{72 \text{ seconds}} = 100 \text{ MBH}$$

For Propane (LP):

$$\text{Input (MBH)} = \frac{9160 \times \text{___ cu ft}}{\text{___ seconds}}$$

Input Rate (MBH)

For Metric formulas- See Glossary

- Compare measured input to table below. If calculated input is not in range given in Table below, check firing rate again after setting the combustion following steps in section 9.10.

Table 9-2 Input Rate @ High Fire (MBH)

Approximate Rate @ 100% Fire (MBH)	
Size	
125	125
150	150

9.15 Parameter Settings

Program boiler electronic board parameters as follows:

- Press and together, hold them down for 6 seconds until program "P01" appears on the display alternated with the set value;
- Press or to scroll the list of parameters;
- Press , value of selected parameter begins flashing, press to change the value;
- Press to confirm the value or press to exit without saving.

Further information in regards to parameters listed in the following table are supplied together with required accessories if necessary.

9.16 Description Of Parameters: Factory Settings		FACTORY SETTINGS	
		125	150
P01	Manufacturer information	01	
P02	Gas used 00 = Gas A (Natural Gas) 01 = Gas E (LPG Gas)	00	
P03	Hydraulic system 00 = instantaneous appliance 03 = instantaneous appliance with pre-heat function 04 = heating only appliance with DHW thermostat 05 = appliance with external storage indirect tank 08 = heating only appliance 13 = instantaneous appliance with pre-heat function for solar application	08	00
P04	Programmable relay 1 setting (optional): 00 = no function is associated 01 = close contact with a room thermostat request (other than ECR thermostat) 02 = close contact with a ECR room thermostat request 03 = relay for indicating low water pressure 04 = relay for error code display 05 = relay for kitchen fan function 07 = relay for post circulation pump 09 = DHW relay on with DHW program setting 10 = DHW relay on with DHW request; if P64 = 1 relay on with CH and DHW request 13 = relay for Cooling function 14 = close contact with room thermostat request (120V~) with post circulation 15 = close contact with open therm remote control request with post circulation	02	
P05	Programmable relay 2 setting (optional): (Same configurations as Relay 1-P04)	04	

parameters continued on
next page

9 - START UP PROCEDURE

9.16 Description Of Parameters: Factory Settings conti.		FACTORY SETTINGS		
		125	150	
P06	Outdoor temperature sensor input configuration 00 = with outdoor temperature sensor connected, external temperature value has influence to calculate heating flow temperature set-point 01 = with outdoor temperature sensor connected, display shows external temperature value (no influence) 02...05 = no function is associated	00		
P07	00..02 = No function is associated 03 = This is an input contact for CH request (e.g. trigger phone). When contact CN2 is closed and Room Thermostat (RT) requiring heat switches burner on. Note: verify heating mode is enabled (winter or heat only mode) 04 = This is an input contact for Low Temperature Thermostat (e.g. floor heating system). When Low Temperature Thermostat connected on CN2 cuts out, burner switches off and display shows E178 anomaly. Note: verify heating mode is enabled (winter or heat only mode) 05 = This is an input contact for external DHW recirculation pump. When contact CN2 is closed the pump runs for a specific period. To enable input it is necessary to set parameter P04 or P05 = 08 and P69 = 05 . Pump will run at P19 minutes (Summer/Winter mode or Only Winter mode) or P19/2 minutes (only Summer mode).	00		
P09	Manufacturer information	--		
P10	Heating set-point setting OT / RT (Open Therm / Room Thermostat 120V~) 00 = with Remote Control (RC) connected, temperature request is RC set-point 01 = Temperature Request is highest set point between RC and PCB 02 = Temperature request is RU setpoint. The RT enable the gas boiler operates	00		
P11..P12	Manufacturer information	--		
P13	Max. heating output (0-100%)	100	80	
P14	DHW max. output (0-100%)	100		
P15	Min. heating output (0-100%)	00		
P16	Maximum CH set-point (°C) 00 = 176°F (80°C) 01 = 113°F (45°C)	00		
P17	Pump overrun time in heating mode (01-240 minutes)	03		
P18	Burner ignition delay in CH mode (00-10 minutes) - 00= 10 seconds	03		
P19	Manufacturer information	07		
P20	Pump overrun time in DHW mode (seconds)	30		
P21	Anti-legionellosis function 00 = Disabled - 01 = Enabled	00		
P22	Manufacturer information (set "22" to display parameters 42 and above)	00		
P23	Maximum DHW set-point temperature 113°-140°F (45°-60°C) , Default 49 = 120°F	49		
P24	Manufacturer information	35		
P25	No water safety device	00		
P26..P31	Manufacturer information	--		
P32..P41	Diagnostics (See SERVICE Instructions)	--		
P44	Temperature unit setting 00 = °C 01 = °F	01		
P71*	Maximum Fan Speed	Setting	115	220
		RPM	6150	7200
P72*	Minimum Fan Speed	Setting	40	40
		RPM	1150	1150
To calculate fan speeds		(P71 x 10) + 5000		
		(P72 x 10) + 750		

NOTE : To scroll to parameters **42 and above**, it is necessary to set **P22** to 22 before scrolling up to the parameter.

* See Tables : SECTION 12.2 - Parameters Setting For High Altitude.

9.17 Adjusting Maximum Heating Power

Maximum boiler heating power can be reduced to suit requirements of heating system it serves.

Table showing parameter **P13** values according to desired maximum power model is shown for each single boiler.

To access and edit **P13** values, proceed as described in Section 9.15 Parameter Settings.

Boiler Model - PARAMETER P13 (%) / Heating Output

Btu/h	KW	MAH-125	MAC-150
20,400	6.0	0	0
23,800	7.0	4	3
27,200	8.0	7	6
30,700	9.0	11	9
34,100	10.0	15	12
40,900	12.0	22	18
47,700	14.0	30	24
54,500	16.0	37	29
61,400	18.0	44	35
68,200	20.0	52	41
75,100	22.0	59	47
81,900	24.0	67	53
88,700	26.0	74	59
95,500	28.0	80	65
102,300	30.0	88	71
109,200	32.0	96	75
112,600	33.0	100	80

FOR YOUR SAFETY READ BEFORE OPERATING

WARNING

If you do not follow these instructions exactly, a fire or explosion may result causing property damage, personal injury or loss of life.

- This appliance is equipped with an ignition device which automatically lights burner. **Do NOT try to light this burner by hand.**
- Before operating smell all around appliance area for gas. Be sure to smell next to floor because some gas is heavier than air and will settle to the floor.
- **Use only your hand to turn the gas shutoff valve.** Never use tools. If valve will not turn by hand, do not try to repair it, call a qualified service technician. Force or attempted repair may result in fire or explosion.
- **Do not use this appliance if any part has been under water.** Immediately call a qualified service technician to inspect appliance and to replace any part of control system and any gas control which has been under water.

CAUTION

WHAT TO DO IF YOU SMELL GAS

- Do not try to light any appliance.
- Do not touch any electrical switch; do not use any phone in your building.
- Immediately call your gas supplier from a neighbor's phone. Follow the gas supplier's instructions.
- If you cannot reach your gas supplier, call the fire department.

10.1 Testing For Gas Leaks And Purging The Gas Supply

- With boiler gas service cock closed (spindle flats at right angles to valve). Pressure test gas supply and inlet pipe work connection to boiler gas service cock for soundness.
- Loosen screw of pressure inlet gas test port on gas valve. See section 13.4 Gas Valve. Verify gas supply is ON. Open boiler service cock to purge.
- Retighten test port screw and test for gas leaks. Close boiler gas shutoff device.

10.2 Boiler Operation

Domestic hot water supply always takes priority over central heating.

Demand for hot water required during central heating period, boiler automatically switches to hot water mode until demand is satisfied i.e. storage water is to required temperature.

This interruption in central heating is only when demand for hot water is present and should not be noticed by the User.

10.3 Central Heating Mode

1. With demand for heating, pump circulates water through the primary circuit.
2. Combustion fan comes on at ignition speed, closing the air pressure switch, allowing power to spark generator and gas valve, creating ignition in the combustion chamber.
3. Flame sensor acknowledges presence of flame in combustion chamber sending a signal to the control board.
4. After initial stabilization period the control board monitors supply and return temperatures and modulates fan speed and gas rate accordingly.
5. Once boiler satisfies CH call for heat, the unit will shutdown and enter 3 minute anti-cycling mode. The boiler pump will operate for 3 minutes to dissipate any residual heat.
If there is a subsequent CH call for heat, boiler will wait 3 minutes to operate.

10.4 Domestic Hot Water Mode

- When a tap is opened and water flow is sensed by DHW flow switch, domestic hot water call for heat is initiated.
- Water in the boiler is diverted from central heating system to domestic hot water heat exchanger to heat incoming domestic water.
- Combustion fan will come on at ignition speed, closing the air pressure switch, allowing power to flow to spark generator and gas valve, creating ignition in the combustion chamber.
- Flame sensor will acknowledge presence of flame in combustion chamber and send a signal to the control board.
- After initial stabilization period, the control board monitors supply and return temperatures and modulates fan speed and gas rate accordingly.
- Domestic call for heat ends when tap is closed and DHW flow switch does not see water flow.
- There is no anti-cycling mode after a DHW call for heat if there is demand.

10.5 Frost Protection

Boiler monitors supply and return water temperatures to enable frost protection which automatically turns boiler and pump on.

If water in boiler falls below 41°F (5°C), providing boiler is connected to power, boiler will operate until water temperature in the system reaches approximately 86°F (30°C).

Frost protection is for boiler only and not for complete Central Heating System.

10.6 Pump

If electricity is connected to the boiler, regardless if power is "On" or "Off" and has not operated for 24 hours for heating or hot water, boiler pump will operate automatically for one minute every 24 hours.

10.7 Low Water Pressure Sensor (Internal)

This device protects primary exchanger from damage. It will not allow boiler to run in a LOW water pressure situation. Low water condition occurs when water pressure drops below 7.0 psi (0.5 bar).

⚠ DANGER

Before servicing, turn off electrical power to boiler at service switch. Close manual gas valve to turn gas supply OFF to boiler. Failure to comply will result in death or serious injury.

⚠ CAUTION

Label all wires prior to disconnection when servicing controls. Wiring errors can cause improper and dangerous operation.

Note Verify proper operation after servicing.

Note Perform regular service and maintenance by qualified service agency at least once every 12 months to assure safe, trouble free operation and maximum efficiency.

Note A Heat Exchanger cleaning kit is available for annual service of the boiler. See repair parts manual for part number.

- Circulator pump and combustion air blower motor furnished with boiler are permanently lubricated from factory and require no further lubrication. Lubricate field sourced pumps and/or motors according to pump and/or motor manufacturer's instruction.
- Check following components are operating properly and are free of blockages or obstructions:
 - air vent;
 - check venturi air inlet for blockage and clean as required;
 - verify pressure test port cap and combustion test port caps are in place;
 - verify supply and return sensors are properly clipped to pipes as close to heat exchanger as possible;
 - Check boiler for any sign of leaks.
- Check external low water cutoff operation (if installed).
 - Check operation by pressing test button on low water cutoff.
 - "Low Water" LED on the external LWCO should illuminate and boiler should shut down.
 - Every 5 years remove low water cutoff. Reinstall after cleaning.
 - Every 10 years replace low water cutoff.
- Visual inspection of flame through sight glass. Burner should be fully illuminated.
- Check heating system expansion tank.

11.1 Beginning of Each Heating Season

- Check boiler area is free from combustible materials, gasoline, and other flammable vapors and corrosive liquids.
- Visually inspect combustion air and vent piping for proper operation. Check for and remove any obstruction to flow of combustion air or vent gases. Immediately repair or replace pipe showing deterioration or leakage. Reassemble per instructions in section 6. Ensure proper reassembly and resealing of system.
- Visually inspect condensate drain line for proper operation. Checking for deteriorated or plugged condensate drain line. Verify condensate trap drains freely and clean as required.
- Test safety relief valve for proper operation. Refer to valve manufacturer's instructions packaged with relief valve.
- Examine heat exchanger, burner, condensate lines, and clean (if necessary) by following instructions in section 11.3 - Component Replacement And Cleaning.

⚠ WARNING

Following service procedures must be performed by qualified service agent. Boiler owner shall not attempt these steps. Failure to do so could result in death or serious injury.

⚠ WARNING

Combustion chamber insulation in this product contains ceramic fiber material. Ceramic fibers can be converted to cristobalite in very high temperature applications. The International Agency for Research on Cancer (IARC) has concluded, Crystalline silica inhaled in the form of quartz or cristobalite from occupational sources is carcinogenic to humans (Group1). Avoid breathing dust and contact with skin and eyes. Use NIOSH certified dust respirator (N95). This type of respirator is based on the OSHA requirements for cristobalite at the time this document was written. Other types of respirators may be needed depending on the job site conditions. Current NIOSH recommendations can be found on the NIOSH website <http://www.cdc.gov/niosh/homepage.html>. NIOSH approved respirators, manufacturers, and phone numbers are also listed on this website. Wear long-sleeved, loose fitting clothing, gloves, and eye protection. Apply enough water to the combustion chamber lining to prevent dust. Wash potentially contaminated clothes separately from other clothing. Rinse clothes washer thoroughly. NIOSH stated First Aid. Eye: Irrigate immediately. Breathing: Fresh air.

⚠ WARNING

Before servicing, turn off electrical power to boiler at service switch. Close manual gas valve to turn gas supply OFF to boiler. Test for gas leaks on any gas carrying components after servicing. Service not complete until appliance operation verified per Installation, Operation & Maintenance Manual provided with boiler.

⚠ CAUTION

Label all wires prior to disconnection when servicing controls. Wiring errors can cause improper and dangerous operation. Failure to follow these instructions could result in minor or moderate injury.

NOTICE

Perform regular service and maintenance by qualified service agency at least once every 12 months to assure safe, trouble free operation and maximum efficiency.

11.2 Maintenance And Routine Servicing

Check and service boiler as necessary.

Frequency of servicing will depend upon installation conditions and usage, manufacturer recommends annually.

- Check flue terminal outside and ensure it is not blocked.
- Operate boiler. Check operation of boiler's controls.
- Ensure all system connections and fittings are sound. Correct any joints and fittings that maybe leaking.
- Follow safety valve manufacturer recommendations for service.

To ensure boiler operates at peak efficiency, following checks must be performed every year:

- check appearance and tightness of gas and combustion circuit gaskets
- check condition and position of ignition and flame sensing electrodes
- check condition of burner and its connection to aluminum front plate
- check for dirt in combustion chamber. Use vacuum cleaner for this cleaning operation
- check gas valve is calibrated correctly using combustion analyzer
- check there is no dirt in condensate trap
- check central heating system pressure
- check expansion tank pressure
- check vent system, clean if necessary

Record details and maintain service history.

11.3 Component Replacement And Cleaning

1. Remove any deposits from heat exchanger using suitable soft brush. *Do not* use brush with metallic bristles.
2. Check condition of the combustion chamber insulation panels. Any damaged panels must be replaced.
3. Check condition of burner and flame ports. Carefully clean with soft brush if necessary. Blockages may be removed with stiffer non-metallic brush. Do not use a brush with metallic bristles this might damage the burner.
4. Remove any fallen deposits from bottom of inner case.
5. Check condition of electrodes.
6. Check spark gap, positioning and height of electrodes.
7. Check fan impeller is clean and free to rotate.

⚠ DANGER

Before servicing, turn off electrical power to boiler at service switch. Close manual gas valve to turn gas supply OFF to boiler. Failure to comply will result in death or serious injury.

11.4 Draining the Boiler

- turn boiler off
- isolate electrical supply
- close boiler gas service cock
- allow boiler to cool
- drain boiler through onboard drain if available or external drain valve.

11.5 Draining the Heating Circuit

- Follow all steps in 11.4.
- Close central heating flow and return valves.
- Connect suitable pipe to drain point.
- Route it to suitable container.
- Open drain tap.

11-1 ELECTRODES

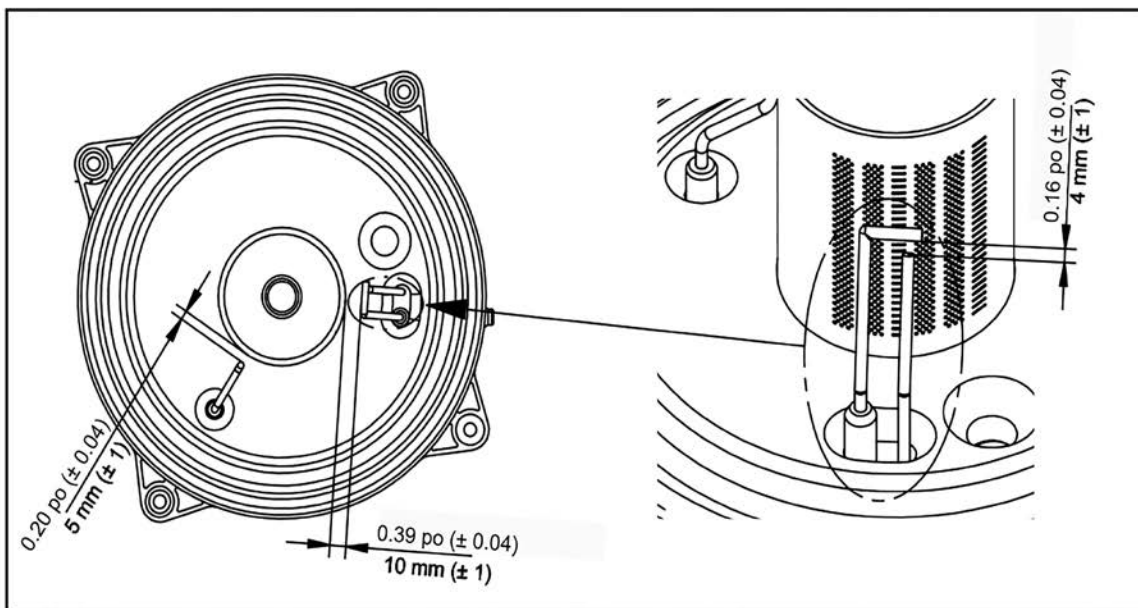

11 - GENERAL MAINTENANCE AND CLEANING

11.6 Hydraulic Unit (DHW)

For special areas, where water is harder than 200 ppm or 12 grains/ gallon, install polyphosphate dispenser or equivalent treatment system, compliant with current regulations.

11.7 Cleaning The Cold Water Filter

Boiler is fitted with cold water filter located on DHW hydraulic assembly (B). To clean:

- Drain domestic hot water system. (C - 150 only)
- Remove the flow sensor on top of assembly.
- Remove nut on DHW priority sensor unit using 18 mm wrench. (B)
- Pull out flow sensor and its filter.
- Soak in white vinegar and water mixture for 20 minutes.

NOTICE

When replacing and/or cleaning "O-rings" on hydraulic assembly (DHW), use only Molykote 111 as a lubricant, not oil or grease.

11.8 Final Commissioning

- Perform Automatic Calibration function as detailed in section 9.8.
- Allow heating system to heat. Balance the system to achieve temperature difference across heating supply and return pipes at the boiler.
- Check system for proper volume and pressure. See page 4 for acceptable volume and pressure.
- Turn off boiler.
- Thoroughly flush water pipe work.
- Repressurize the system.

11.9 Final Assembly

- Place front jacket in position over boiler. Secure in position at top using screws previously removed.
- If boiler is to be left in service with the User, set controls and room thermostat.
- If boiler is not to be handed over immediately, close boiler gas service valve and turn off electrical supply.
- If there is possibility of boiler being left during frost conditions drain boiler and system. See section 11: Component Replacement Or Periodic Cleaning. Manufacturer recommends attaching a label to the boiler drawing attention to the fact that the system has been drained.

Model MACF-150

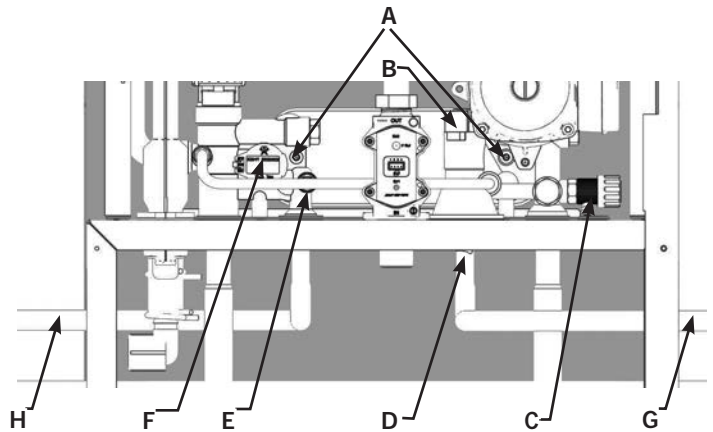

LEGEND

Hydraulic Assembly (Combi-150)

A	DHW exchanger screw
B	DHW priority sensor
C	Boiler/system drain tap
D	Controlled fast fill
E	DHW temperature NTC probe
F	Low Water Pressure Cutoff
G	DHW Cold inlet
H	DHW outlet

11.10 User Information

Advise and demonstrated to User the following important information:

- A. How to light and turn off boiler. How to operate system controls.
- B. Importance of annual servicing of boiler to ensure safe and efficient operation.
- C. Servicing or replacement of parts shall be carried out by a qualified personnel.
- D. Ensure boiler controls and room thermostat, if fitted, are set to User's requirements.
- E. Tell User about sealed system pressure.
- F. Tell User if display is active and boiler has not operated for 24 hours for heating or hot water, the pump will automatically operate for 1 minute.
- G. Explain to User an internal frost thermostat is fitted in boiler, and electrical supply to boiler must be left on for frost protection to operate.
- H. Show User position of pressure relief valve discharge pipe.
- I. Leave this Installation, Operation and Maintenance Manual with User for use on future calls.

11.11 Safety Flue Thermostat - *DO NOT* disable this safety device.

Safety Flue Thermostat found on the flue inside the boiler, interrupts flow of gas to the burner if the temperature overheats.

After verifying the cause of the trip, press  for about 2 seconds.

11.12 Flue Pressure Switch (125-150 Only)

DO NOT disable this safety device.

This device, positioned inside the sealed chamber, interrupts flow of gas to the burner if flue pressure exceeds 1.6 in w.c. (4 mbar). Verify if vent is blocked before resetting the boiler.

NOTICE

When servicing the appliance, check the condition and position of flame sensing electrode and replace it if necessary.

11.13 Replacement Parts

Perform Automatic Calibration procedure described in section 9.8 if one or more of the following components are replaced. Check and adjust CO₂% value as indicated in the Combustion Table.

Components replaced:

- Primary heat exchanger
- Fan
- Gas valve
- Gas orifice
- Burner
- Flame sensing electrode
- Spark electrode

12 TECHNICAL DATA

12.1 Ratings and Capacity

					
Model Number	CH Input, MBH ⁽¹⁾		⁽¹⁾⁽²⁾ CH Heating Capacity, MBH *	⁽¹⁾⁽³⁾ Net AHRI Rating Water, MBH	⁽²⁾ AFUE%
	Maximum	Minimum			
MAHF-125	125	22	113	98	95.0
MACF-150	125	22	113	98	95.0
<p>(1) 1000 Btu/hr (British Thermal Units Per Hour)</p> <p>(2) Heating Capacity and AFUE (Annual Fuel Utilization Efficiency) are based on DOE (Department of Energy) test procedures.</p> <p>(3) Net AHRI Ratings based on piping and pickup allowance of 1.15. Contact Technical Support before selecting boiler for installations having unusual piping and pickup requirements, such as intermittent system operation, extensive piping systems, etc.</p>					

*Max CH Supply temp 176° F (80°C)

12.2 Domestic Hot Water Specifications

Item	MACF-150	
Input Ratings (MBH)	Min	22
	Max	153
Output Ratings (MBH)	Min	19
	Max	136
Domestic Water Pressure	2.9 psi (0.2 bar) - 116 psi (8.0 bar)	
Minimum Flow Rate	0.50 GPM	
Maximum Flow Rate	3.50 gpm	
Flow Rate 77°F (43°C) Temp. Rise	3.25 gpm	
DHW Supply Connection Size	1/2" Sweat	
Cold Water Input Connection Size	1/2" Sweat	

*Max DHW temp 140° F (60° C)

12.3 High Altitude Ratings and Capacity

For elevations between 2000 ft (600 m) and 10,000 ft (3048 m), use the following information:

Altitude	Model Number	Input, MBH (KW)		Heating Capacity, MBH*	AFUE, %	Domestic Hot Water (DHW) Circuit**			
		Maximum	Minimum			Max Input, MBH	Min Input, MBH	Max Output, MBH	Min Output, MBH
2,000-4,500 ft (600m-1350m)	MAHF-125	113	22	101	95.0				
	MACF-150	113	22	101	95.0	137	22	122	19

* Max CH Supply temp 176° F (80° C) for MAHF-125 and MACF-150
 **MACF-150 Max DHW Flow rate 3.5 gpm (13.2 l/min)

12.4 High Altitude Chart

	GAS		Natural		LP	
	Model		Altitude			
			0-2,000 ft. [0-610 m]	2,000- 10,000 ft [610-3,048 m]	0-2,000 ft. [0-610 m]	2,000- 10,000 ft [610-3,048 m]
Parameter P71 High Fire Fan Speed	125	Setting RPM	115 6150	60 5600	65 5650	40 5400
	150	Setting RPM	220 7200	170 6700	170 6700	150 6500
Parameter P72 Low Fire Fan Speed	125	Setting RPM	40 1150		25 1000	
	150	Setting RPM	40 1150		25 1000	

CO Limit < 200 ppm

13 - TROUBLE SHOOTING

13.1 Error Messages And Resetting The Boiler

E	Error Description	Operation
09	Gas valve connection fault	Check cable PCB/gas valve and gas valve plug
10	Outdoor sensor fault	Check sensor and cable
15	Gas valve command fault	Verify all cables. Replace PCB. Call authorized SERVICE center
20	Central Heating NTC sensor fault	Check sensor and cable
28	Flue NTC heat exchanger sensor fault	Check sensor and cable
40	Return NTC sensor fault	Check sensor and cable
50	Domestic Hot Water NTC sensor fault	Check sensor and cable
53	Obstruction in flue pipe, Recirculation, Out of Calibration, Poor gas quality	Check for obstruction in flue pipe. Check gas pressure, check gas orifice. Check for recirculation, recalibrate, check gas quality.
55	PCB not programmed	Call authorized SERVICE center
E72/E92	R	Combustion test alarm during commissioning / calibration
		Check flame sensor, check for obstruction in flue pipe, check for recirculation, check gas pressure, check gas orifice, check gas quality. Perform Calibration Function.
E83	OT Communication Failure	Check OT connection, remove power, reconnect OT connections, if problem persists replace service key.
84-86-87	Communication problem between boiler board and control unit	Probable short circuit on wiring. Check cable between control unit and boiler
109	Pre-circulation alarm (temporary fault)	Check correct circulation of water and pump. Check supply and return wiring is correct.
110	R	Safety thermostat tripped due to over temperature (pump probably blocked or air in heating circuit)
		Check safety thermostat and cable; check correct circulation of water and pump
118	Hydraulic pressure too low.	Refill heating system by opening cold water tap
117	Hydraulic pressure too high.	Relieve pressure via relief valve or drain. Ensure water feed is operating correctly.
125	R	No circulation of water (control performed via temperature sensor).
		Check correct circulation of water and pump. Check correct connection of NTC sensor on pipe
128	R	Loss of flame
		Check sensing electrode and cable, flue recirculation, electrical continuity between burner and ground, gas pressure, gas orifice. Enable automatic calibration. Call authorized SERVICE center.
130	R	NTC flue sensor tripped due to over temperature
		Check thermostat, correct circulation of water and pump. Check status of primary exchanger.
131	R	Thermo fuse tripped due to over temperature or wire harness disconnected from thermo fuse, off the board, or wire harness may be cut.
		Check thermo fuse, correct circulation of water and pump. Check status of primary exchanger. Replace heat exchanger. Call authorized SERVICE center. Verify wire harness installation and continuity.
133	R	Ignition failure
		Check correct operation of condensate trap. Check sensing electrode, spark electrode and cable. Check flue recirculation, electrical continuity between burner and ground. Check gas orifice and gas pressure. Enable automatic calibration function. Call authorized SERVICE center
134	R	Gas supply valve blocked
		Check gas pressure, sensing electrode, spark electrode and cable, replace PCB if it necessary. Call authorized SERVICE center
135	Internal error	Verify all cables. Replace PCB. Call authorized SERVICE center
160	Fan fault	Check fan and cable
162/317	Incorrect power supply frequency.	Incorrect power supply frequency.

13.1 Error Messages and Resetting the Boiler - continued

E	Error Description	Operation
169	Flue pressure switch (contact open)	Check pressure switch and cable. Check obstruction on flue pipe
164/384 R	Fault flame (parasitic flame).	Check correct operation of T. gas valve.
165/385	Input voltage too low.	Check power supply
E178	Low return water temperature / anti-freeze function active	Check the return water sensor, check the circulator, check the correct circulation of the water. Boiler will exit status when condition is resolved.

To RESET **R** boiler press  button for at least 2 seconds.

For other error codes not described in table please contact manufacturer at 1(800) 325-5479.

Anomalies Only Displayed in the Fault History		
E62	Anti-wind activation with increase of the minimum fan speed	Check the position of the terminal of the flue duct.
E63/E65	Combustion level out of range	Check flue recirculation and combustion levels.
E65	Maximum value of the speed reached / correction of the flame signal	Check flue recirculation on the flue duct.
E67	Anti-wind activation at maximum power	Check the position of the terminal of the flue duct.
E69	Combustion level out of range	Check flue recirculation and the combustion levels.
E70	Flame signal problem/micro interruption of the flame signal	Check cable and integrity of the sensing electrode, verify the continuity between burner and earth.
E73	Combustion adjustment / modified during operation	Review and monitor other codes such as E53 and E92

13 - TROUBLE SHOOTING

13.2 Anomalies Table for the Installer - Use this table to report the anomaly values.

SYSTEM STATUS CODES
 0 STANDBY
 1 DHW "ON"
 2 CHIMNEY SWEEP ACTIVE
 3 CH "ON"
 4 PREHEAT "ON"
 5 CH NO FROST "ON"
 6 DHW NO FROST "ON"
 8 THERMOSTATIC POST- CIRCULATION

FAILURE CODE

NUMBER OF TIMES OCCURRED

TEMPERATURE

		Anomaly Number	Anomaly Code	Consecutive Counter for the Same Anomaly	Number of Days Elapsed From the Anomaly Event	System Status	Phase Status	CH Flow Temperature Value During the Anomaly vent
NO RESET ANOMALY	P32	C00						
	P33	C01						
	P34	C02						
	P35	C03						
	P36	C04						
	P37	C05						
RESET ANOMALY	P38	C06						
	P39	C07						
	P40	C08						
	P41	C09						

C00: LAST FAILURE
 C06: FIRST FAILURE
 C07: LAST LOCKOUT
 C09: FIRST LOCKOUT

PHASE STATUS CODES
 0: STANDBY
 1: PREPURGE
 3: INTERPURGE
 4: SAFETY TIME
 5: RUNNING
 6: LOCKOUT
 11: INTERURGE
 15: POST VENTILATION
 16: THERMOSTATIC POST VENTILATION

- **APPLIANCE** - Device to convert gas into energy; term includes any component, control, wiring, piping or tubing required to be part of the device.
- **ANSI** - American National Standards Institute, Inc. oversees the creation and maintenance of voluntary consensus standards, including ANSI Z21.13/CSA 4.9: Gas-Fired Low Pressure Steam and Hot Water Boilers.
- **ASME - Association of Mechanical Engineers**
Establishes rules of safety governing the design, fabrication, and inspection of boilers and pressure vessels, determining the MAWP of such vessels.
- **ASTM** - American Society for Testing and Materials. ASTM International is one of the largest voluntary standards development organizations in the world, a trusted source for technical standards for materials, products, systems, and services. Known for their high technical quality and market relevancy, ASTM International standards have an important role in information infrastructure that guides design, manufacturing and trade in the global economy.
- **AUTHORITY HAVING JURISDICTION** - Individual or organization adopting and enforcing codes, rules, and by-laws governing various concerns of a community. Commonly referred to as "final authority" for any matters relating to LIFE SAFETY and BUILDING CONSTRUCTION within a community.
- **BOILER** - Appliance intended to supply hot liquid for space-heating, processing or power purposes.
- **BTU** - Abbreviation for British Thermal Unit. Quantity of heat required to raise the temperature of 1 pound of water 1°F.
- **BURNER** - Device for the final conveyance of gas or mixture of gas and air, to the combustion zone.
- **CALIBRATE** - Make fine adjustments or divide into marked intervals for optimal measuring.
- **COAXIAL VENTING** - Sharing the same center.
- **COMBUSTION** - Rapid oxidation of fuel gases accompanied by the production of heat or heat and light. Complete combustion of fuel is possible only in the presence of an adequate supply of Oxygen.
- **COMBUSTIBLE MATERIAL** - Materials made of or surfaced with wood, compressed paper, plant fibers, or other materials capable of being ignited and burned. Such material shall be considered combustible even though flame-proofed, fire-retardant treated, or plastered.
- **COMBUSTION AIR** - Air that is drawn into an appliance to mix with fuel and support combustion.
- **CONDENSATE** - Liquid separated from flue gas due to a reduction in temperature.
- **DIRECT VENT BOILER** - Boiler constructed and installed so that all combustion air is derived directly from outdoors and all vent gases are discharged to outdoors.
- **DOMESTIC** - Relating to household usage as opposed to commercial usage.
- **DOMESTIC WATER** - Potable drinking water - tap water.
- **DRAFT** - Pressure difference causes gases or air to flow through a chimney, vent, flue or appliance.
- **FLA** - Full load amps.
- **FLUE** - Enclosed passageway for conveying combustion gases.
- **FLUE GASES** - Products of combustion plus excess air in appliance flues or heat exchangers.
- **GAS SUPPLIER** - Party that sells the commodity of Natural Gas (Gas A) or LPG (Gas E).
- **HIGH-VOLTAGE** - Circuit involving a potential of not more than 600 volts and having circuit characteristics in excess of those of a low-voltage circuit.
- **HYSTERESIS (DIFFERENTIAL)** - Difference between the temperature at which the thermostat switches off - and the temperature at which it switches on again.
- **IGNITER** - Device utilizing electrical energy to ignite gas at the main burner.
- **LEAK CHECK** - Operation performed on a gas piping system to verify the system does not leak.
- **LICENSED QUALIFIED INSTALLER / SERVICE TECHNICIAN** - Any individual, firm, corporation or company that either directly or through a representative is engaged in the installation, replacement, repair or servicing of gas piping, venting systems, appliances, components, accessories, or equipment, and whose representative is experienced and trained in such work and has complied with the requirements of the authority having jurisdiction.
- **LOW WATER CUTOFF** - Device constructed to automatically cut off fuel supply when the surface of water in the boiler falls to the lowest safe water level.
- **LOW-VOLTAGE** - Circuit involving a potential of not more than 30 volts.

- **METRIC GAS METERS**

- **Natural Gas**

$$\text{MBH} = \frac{127,116 \times \text{cu meters}}{\text{Seconds}}$$

For example: Gas Meter measures 0.1 cubic Meters in 100 seconds

$$\text{MBH} = \frac{127,116 \times 0.1}{100} = 127 \text{ MBH}$$

- **Propane Gas (LP)**

$$\text{MBH} = \frac{383,482 \times \text{cu meters}}{\text{Seconds}}$$

- **NATIONAL BOARD OF BOILER AND PRESSURE VESSEL**

INSPECTORS - Group composed of boiler and pressure vessel inspectors representing states, cities and provinces enforcing pressure equipment laws and regulations.

- **PRESSURE TEST** - Operation performed to verify gas tight integrity of gas piping following its installation or modification.
- **PURGE** - To free gas conduit of air or gas, or mixture of gas and air.
- **PURGE TIME** - Period of time intended to allow for dissipation of any unburned gas or residual products of combustion.
- **QUALIFIED AGENCY** - Any individual, firm, corporation, or company engaged in and responsible for:
 - Installation, testing, or replacement of gas piping, or connection, installation, testing, repair or servicing of appliances and equipment.
 - Experienced in such work.
 - Familiar with all precautions required.
 - Complies with all requirements of authority having jurisdiction.
- **SAFETY RELIEF VALVE** - Valve designed to relieve pressure in hot water supply system when pressure exceeds pressure capability of equipment.
- **SAFETY SHUTOFF DEVICE** - Device that will shut off gas supply to controlled burner in event source of ignition fails.
- **SEDIMENT TRAP** - Gas piping arrangement designed to collect any liquid or solid contaminant before reaching gas valve.
- **SERVICE** -Supply, installation, or maintenance of goods carried out by a Qualified Installer / Service Technician.

- **TWO PIPE SYSTEM** - Type of venting that allows for exhaust flue and intake air piping to be separated from each other. Fresh air may be drawn in at a different area from where flue terminal is located.
- **VENT** - Passageway used to convey flue gases from appliance vent connector to outdoors.
- **VENTING SYSTEM** - Continuous open passageway from of appliance vent connector to outdoors for purpose of removing flue or vent gases.

A-1 MODELS 125 - Heat Only

240011359 REV C 125

LEGEND - LEGENDE:

- 1-FUSES 3, 15 A - Fusibles 3, 15 A
- 2-Supply 120V - 60Hz - Alimentation
- 3-Fan - Ventilator
- 4-Air pressure switch - Pressostat différentiel fumées
- 5-Safety Thermostat - Thermostat de Sécurité
- 6-Gas Valve - Vanne a gaz
- 7-Exchanger sensor - Sonde échangeur
- 8-Water Pressure Switch - Pressostat Eau
- 9-NTC return Sensor - Sonde NTC retour
- 10-NTC flow sensor - Sonde NTC départ
- 11-Flue Safety Thermostat - Thermostat Fumées
- 12-Remote User Interface or Open Therm
- 13-Prev. for OutsideSensor - Pred. Sonde Extérieure
- 14-Link 24V - Joint 24V
- 15-DHW Indirect sensor or T-Stat
- 16-Flame Sensing Electrode - Electrode présence veilleuse
- 17-Ignition Electrode - Electrode d'allumage
- 18-Three Way Valve - Soupape Trois Voies
- 19-Pump - Pompe
- M1-Main Power Terminal Board - Bornier d'alimentation
- M2-Accessories Terminal Board - Bornier pour accessoires

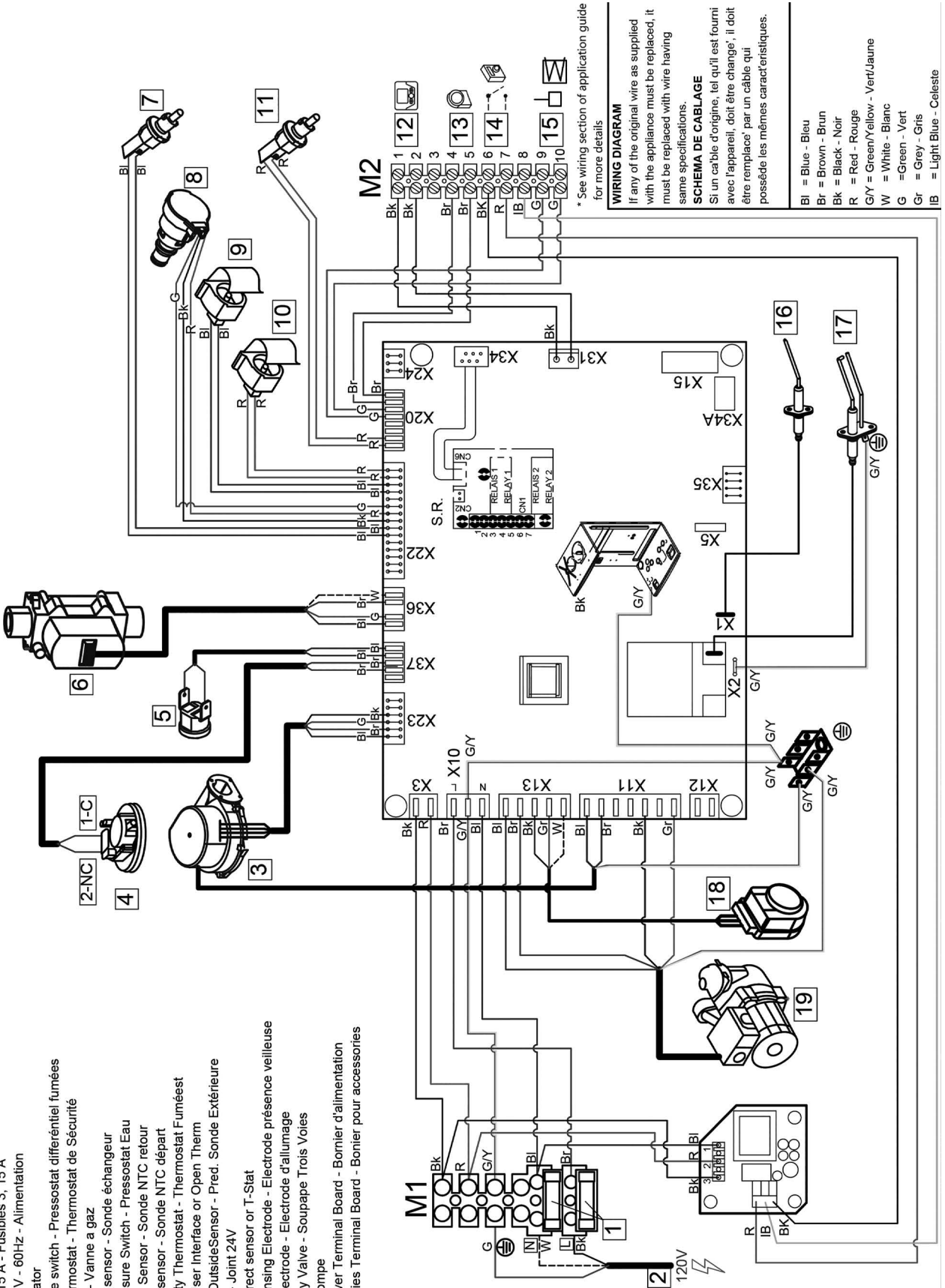

WIRING DIAGRAM
 If any of the original wire as supplied with the appliance must be replaced, it must be replaced with wire having same specifications.
SCHEMA DE CABLAGE
 Si un câble d'origine, tel qu'il est fourni avec l'appareil, doit être changé, il doit être remplacé par un câble qui possède les mêmes caractéristiques.

* See wiring section of application guide for more details

BI = Blue - Bleu
 Br = Brown - Brun
 Bk = Black - Noir
 R = Red - Rouge
 W = White - Blanc
 G = Green - Vert
 Gr = Grey - Gris
 IB = Light Blue - Celeste

A-2 MODELS 150 - Combi

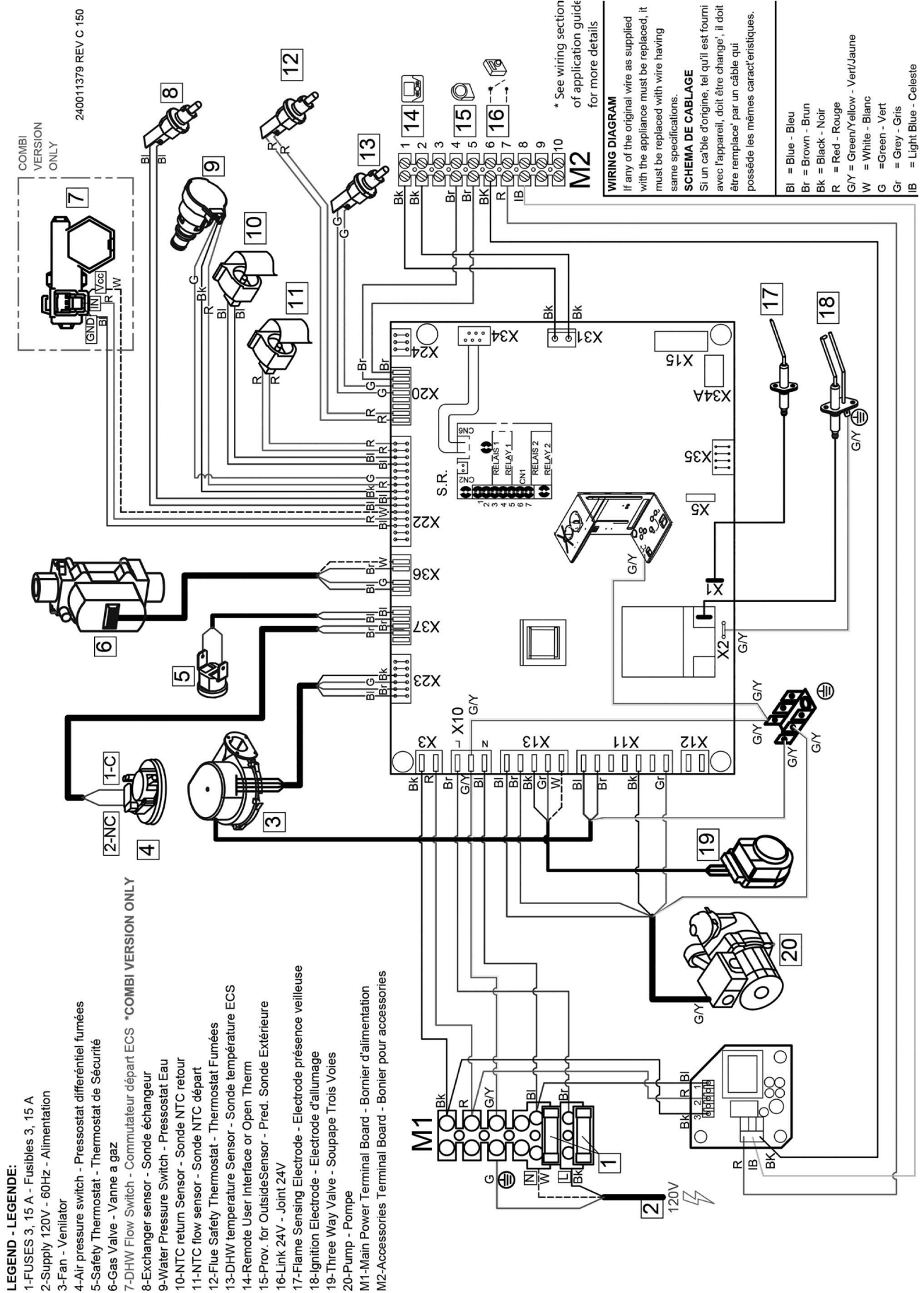

INSTALLATION AND CHECK-OUT CERTIFICATE

Boiler Model _____ **Serial #** _____ **Date Installed** _____

Measured BTU/HR input _____

- Installation instructions have been followed**
- Checkout procedure and adjustments performed**
- Maintenance and Service issues reviewed with owner/ maintenance person**
- Installation booklet affixed on or adjacent to boiler**

Installer (Company) _____

Address _____

Phone _____

Installer's Name _____

Signature _____

IMPORTANT

In accordance with Section 325 (f) (3) of the Energy Policy and Conservation Act, this boiler is equipped with a feature that saves energy by reducing the boiler water temperature as the heating load decreases.

This feature is equipped with an override which is provided primarily to permit the use of an external energy management system that serves the same function.

THIS OVERRIDE MUST NOT BE USED UNLESS AT LEAST ONE OF THE FOLLOWING CONDITIONS IS TRUE:

- An external energy management system is installed that reduces the boiler water temperature as the heating load decreases.
- This boiler is not used for any space heating
- This boiler is part of a modular or multiple boiler system having a total input of 300,000 BTU/hr or greater.
- This boiler is equipped with a tankless coil.



ECR International Inc. 2201 Dwyer Avenue, Utica, NY 13501
Tel. 800 253 7900
www.ecrinternational.com

All specifications subject to change without notice.
©2018 ECR International, Inc.