

INSTALLATION MANUAL

Multi-position, Upflow, and Horizontal DX and Chilled Water Cooling with Electric Heating

MODELS: MS, MM, US, UM SERIES

LIST OF SECTIONS

1 – General	1	7 – Line Voltage Wiring	13
2 – Safety	2	8 – Field Installed Electric Heater Kits	16
3 – Clearance and Return Air Requirements	6	9 – Thermostat Wiring and Connections	17
4 – Furnace and Supply Air Duct Installation	8	10 – Motor, Blower and Furnace Startup	23
5 – Furnace Installation	10	11 – Final System Checkout	25
6 – Hydronic Heating / Cooling / Refrigerant Piping	10	12 – Wiring Diagrams	26

LIST OF FIGURES

1 – Dimensional Data DX Cool With or Without Electric Heat	4	24 – 2 Stage Heat w/ 2 Stage Split System Cooling Wiring Diagram	19
2 – Dimensional Data Chilled Water With or Without Electric Heat	5	25 – 1 Stage Heat w/ 2 Stage Package Cooling Wiring Diagram	19
3 – Clearance – Access for Service	7	26 – 2 Stage Heat w/ 2 Stage Split System HP Wiring Diagram	20
4 – Closet Clearances	7	27 – 2 Stage Heat w/ 2 Stage Package HP Wiring Diagram	20
5 – Typical Closet Installations	8	28 – X-13 Motor Terminals	22
6 – Accessory Air Filter Box for 1” or 2” Air Filters	8	29 – Blower Assembly and Blower Deck Drawing	22
7 – Evaporator Coil Disassembly for Conversion to Downflow	9	30 – ECM Motor Control Plug Pin out	22
8 – Evaporator Coil Assembly to Convert to Downflow	9	31 – ECM Control Board Diagram	23
9 – Combustible Floor Base – Downflow Operation	10	32 – MSVE 18-72 – ECM – No Electric Heater Wiring Diagram	24
10 – Installing Evaporator Below Condenser – Piping	10	33 – MSVE 18-72 – ECM – 5 kW Electric Heater Wiring Diagram	25
11 – TXV Trouble Shooting Guide	11	34 – MSVE 25-72 – ECM – 10 kW Electric Heater Wiring Diagram	25
12 – Typical TXV Connections	12	35 – MSVE 37-72 – ECM – 15 kW Electric Heater Wiring Diagram	26
13 – Flowrator Distributor	12	36 – MSVE 42-72 – ECM – 20 kW Electric Heater Wiring Diagram	26
14 – Typical Condensate Trap	13	37 – MSVT 18-72 – X-13 – No Electric Heater Wiring Diagram	27
15 – Component Locations – Electric Heat Control Box	15	38 – MSVT 18-72 – X-13 – 5 kW Electric Heater Wiring Diagram	27
16 – Component Locations – No Heat Control Box	15	39 – MSVT 18-72 – X-13 – 10 kW Electric Heater Wiring Diagram	28
17 – Control Box Circuit Breaker Locations	16	40 – MSVT 36-72 – X-13 – 15 kW Electric Heater Wiring Diagram	28
18 – Circuit Breaker Location on Front Panel	16	41 – MSVT 37-72 – X-13 – 20 kW Electric Heater Wiring Diagram	29
19 – No Heat and Factory Installed Electric Heat Control Box	17	42 – MSPS 18-60 – PSC – No Electric Heater Wiring Diagram	29
20 – 1 Stage Heat w/ 1 Stage Split System Cooling Wiring Diagram	18	43 – MSPS 18-60 – PSC – 5 kW Electric Heater Wiring Diagram	30
21 – 1 Stage Heat w/ 1 Stage Package Cooling Wiring Diagram	18	44 – MSPS 18-60 – PSC – 10 kW Electric Heater Wiring Diagram	30
22 – 1 Stage Heat w/ 1 Stage Split System HP Wiring Diagram	19	45 – MSPS 30-60 – PSC – 15 kW Electric Heater Wiring Diagram	31
23 – 1 Stage Heat w/ 1 Stage Package HP Wiring Diagram	19	46 – MSPS 37-60 – PSC – 20 kW Electric Heater Wiring Diagram	31

LIST OF TABLES

1 – Air Handler Model Specifications	3	10 – Electrical Data	15
2 – Dimensional Data DX Cooling With or Without Electric Heat	4	11 – Field Installed Electric Heater Kit Model Numbers	16
3 – Dimensional Data Chilled Water With or Without Electric Heat	5	12 – Field Installed Accessory Heater Kit Nomenclature	17
4 – Air Handler Model Nomenclature	6	13 – Low Voltage Wire gauge and Maximum Lengths	17
5 – Clearances to Combustibles	7	14 – Recommended Heating / Cooling Thermostat Wire Colors	20
6 – Wiring Requirements – 18-36 kBTU – Single Branch Circuit	14	15 – Recommended Heating / Cooling / HP Thermostat Wire Colors	20
7 – Wiring Requirements – 37-60 kBTU – Single Branch Circuit	14	16 – X-13 Motor Terminal Connections	21
8 – Wiring Requirements – 25-60 kBTU – Dual Branch Circuit	14	17 – ECM Motor Control Connector Terminal Descriptions	22
9 – Wiring Requirements – 37-72 kBTU – Dual Branch Circuit	15		

SECTION I: GENERAL

The following list includes important facts and information regarding the electric furnace and its inclusions.

1. Air handler is rated at either 120 volts AC or 240 volts AC at 60 Hertz
2. Air handler size varies by model
3. Four-wire thermostat operation for heating and cooling
4. Seven wire thermostat for heat pump operation.
5. Air Handlers equipped with blower for A/C or Heat Pump operation

6. This air handler is designed for multi position, upflow and horizontal application
7. This air handler must not be operated without the door installed

NOTE: This air handler and its components listed on the A/C and Heat Pump equipment sticker were listed in combination as a system by ETL for the United States and Canada.

SAVE THIS MANUAL FOR FUTURE REFERENCE



SECTION II: SAFETY



This is a safety alert symbol. When you see this symbol on labels or in manuals; be alert to the potential for personal injury. Understand and pay particular attention to the signal words **DANGER, WARNING, or CAUTION.**

DANGER: indicates an **imminently** hazardous situation, which if not avoided, **will result in death or serious injury.**

WARNING: indicates a **potentially** hazardous situation, which if not avoided, **could result in death or serious injury.**

CAUTION: indicated a **potentially** hazardous situation, which if not avoided, **may result in minor or moderate injury.** It is also used to alert against unsafe practices and hazards involving property damage.

WARNING

Improper installation may create a condition where the operation of the product could cause personal injury or property damage.

Improper installation, adjustment, alteration, service or maintenance can cause injury or property damage. Refer to this manual for assistance; or for additional information consult a qualified contractor, installer, or service agency.

WARNING

FIRE OR ELECTRICAL HAZARD

Failure to follow the safety warnings exactly could result in serious injury, death, or property damage.

A fire or electrical hazard may result causing property damage, personal injury or loss of life.

CAUTION

This product must be installed in strict compliance with the installation instructions and any applicable local, state, and national codes including, but not limited to; building, electrical, and mechanical codes.

IMPORTANT

The Clean Air Act of 1990 bans the intentional venting of refrigerant (CFC's and HFC's) as of July 1, 1992. Approved methods of reclaiming must be followed. Fines and/or incarceration may be levied for non-compliance

Safety Requirements

This appliance should be installed in accordance with all national and local building/safety codes and requirements, local plumbing or waste water codes, and other applicable codes. In the absence of local codes, install in accordance with the following codes.

- Standard for the Installation of Air Conditioning and Ventilating Systems (NFPA 90A)
- Standard for the Installation of Warm Air heating and Air Conditioning Systems (NFPA 90B)
- National Electrical Code (NFPA 70)
- Canadian Electrical Code, Part I (CSA C22.2) or ANSI/NFPA No. 70
- All local codes (State, City, and Township)

NOTE: All applicable codes take precedence over any recommendation made in these instructions.

SunTherm assumes no responsibility for units installed in violation of any code or regulation.

1. Refer to the unit rating plate for the air handler model number, and then see the dimensions page of this instruction for return air plenum dimensions in Figures 1 and 2. The plenum must be installed according to the above listed codes or the instructions in this manual.
2. Refer to the dimensions page of this instruction and the duct connector and combustible floor base dimensions shown in Figure 9 for the proper duct connector or combustible floor base for downflow applications. The duct connector and combustible floor base must be installed according to the instructions in this manual.
3. These models **ARE NOT** ETL listed or approved for installation into a **Manufactured (Mobile) Home.**
4. Provide clearances from combustible materials as listed under **Clearances to Combustibles.**
5. Provide clearances for servicing ensuring service access is allowed for the control box, electric elements, hot water coil and the blower.

WARNING

Hot water from a boiler used to satisfy heating requirements can be heated to temperatures of 180°F. Parts containing water this hot can scald very quickly. Use extreme caution when servicing or performing maintenance on any parts containing hot water.

6. Check the rating plate and the power supply to be sure the electrical characteristics match.
7. Failure to carefully read and follow all instructions in this manual can result in malfunction of the air handler, death, personal injury, and/or property damage.
8. Electric air handler shall be installed so the electrical components are protected from water.
9. Installing and servicing heating/cooling equipment can be hazardous due to electrical components.
10. Only trained and qualified personnel should install repair or service heating/cooling equipment. Untrained service personnel can perform basic maintenance functions such as cleaning of exterior surfaces and replacing the air filters. Observe all precautions in the manuals and on the attached labels when working on this appliance.
11. These instructions cover minimum requirements and conform to existing national standards and safety codes. In some instances these instructions exceed certain local codes and ordinances, especially those who have not kept up with changing home and/ or HUD construction practices. These instructions are to be followed and are the minimum requirement for a safe installation.
12. The size of the unit should be based on an acceptable heat loss calculation for the structure. ACCA, Manual J or other approved methods may be used.
13. Check the rating plate and power supply to be sure that the electrical characteristics match. The 115 VAC models use nominal 115 VAC, 1 Phase, 60-Hertz power supply. **DO NOT CONNECT THIS APPLIANCE TO A 50 HZ POWER SUPPLY OR A VOLTAGE ABOVE 130 VOLTS.**
14. The 208/230 VAC models use nominal 208 or 230 VAC, 1 Phase, 60-Hertz power supply. **DO NOT CONNECT THIS APPLIANCE TO A 50 HZ POWER SUPPLY OR A VOLTAGE ABOVE 250 VOLTS.**
15. Ground connections **MUST BE** securely fastened to the control box and ground wires **MUST BE** secured to the ground lugs control box with terminals.

▲ WARNING

ALWAYS SHUT OFF ELECTRICITY AT THE DISCONNECT SWITCH OR TURN OFF THE CIRCUIT BREAKERS IN THE MAIN ELECTRICAL ENTRANCE BEFORE PERFORMING ANY SERVICE ON THE APPLIANCE.

GENERAL INFORMATION

This single piece air handler provides the flexibility for installation in any upflow, downflow, or horizontal application. The versatile models may be used with or without electric heat or hot water heat. The direct drive variable speed ECM motor, optional (3) speed PSC motor, or the (5) five speed X-13 motors provide a selection of air volume to match any application. The unit can be positioned for bottom air return in the upflow position, top air return in the downflow position, or air return through the end of the unit in the horizontal position.
 NOTE: Refer to the instructions in this manual for the proper downflow conversion kit and instructions on the proper conversion to downflow.

Inspection

As soon as the furnace is received, it should be inspected for possible damage during transit. If damage is evident, the extent of the damage should be noted on the carrier's freight bill. A separate request for inspection by the carrier's agent should be made in writing. Before installing the air handler you should check the cabinet for screws or bolts which may have loosened in transit. There are no shipping or spacer brackets which need to be removed before startup.

See local Distributor for more information. Mortex Products, Inc assumes no liability for freight damage.

Also check to be sure all accessories such as heater kits, and coils are available. Installation of these accessories should be accomplished before the air handler is set in place or the connecting of the wiring, electric heat, ducts or piping.

Cooling Only & Cooling W/Electric Heat				
Models	MS**18,24	MS**25,30,36	MS**37,42,48,60	MS**72
Input, kW	5,10	5,10,15	5,10,15,20	5,10,15,20
Blower Size-Heat (D x W)	9 X 6	10 X 7	12 X 9	12 X 10
Unit Voltage	240V, 60 HZ, 1 PH			
Max. External SP (Duct), In. W.C.	0.50			
Thermostat Circuit	24 VAC, 60 Hz, 40VA			

Table 1 Air Handler Model Specifications

Available Blower Motors

1. Standard Blower Motor - – VAR SPD ECM MOTOR
2. Optional Blower Motor - 3 SPD PSC MOTOR
3. Optional Blower Motor – 5 SPD X-13 MOTOR

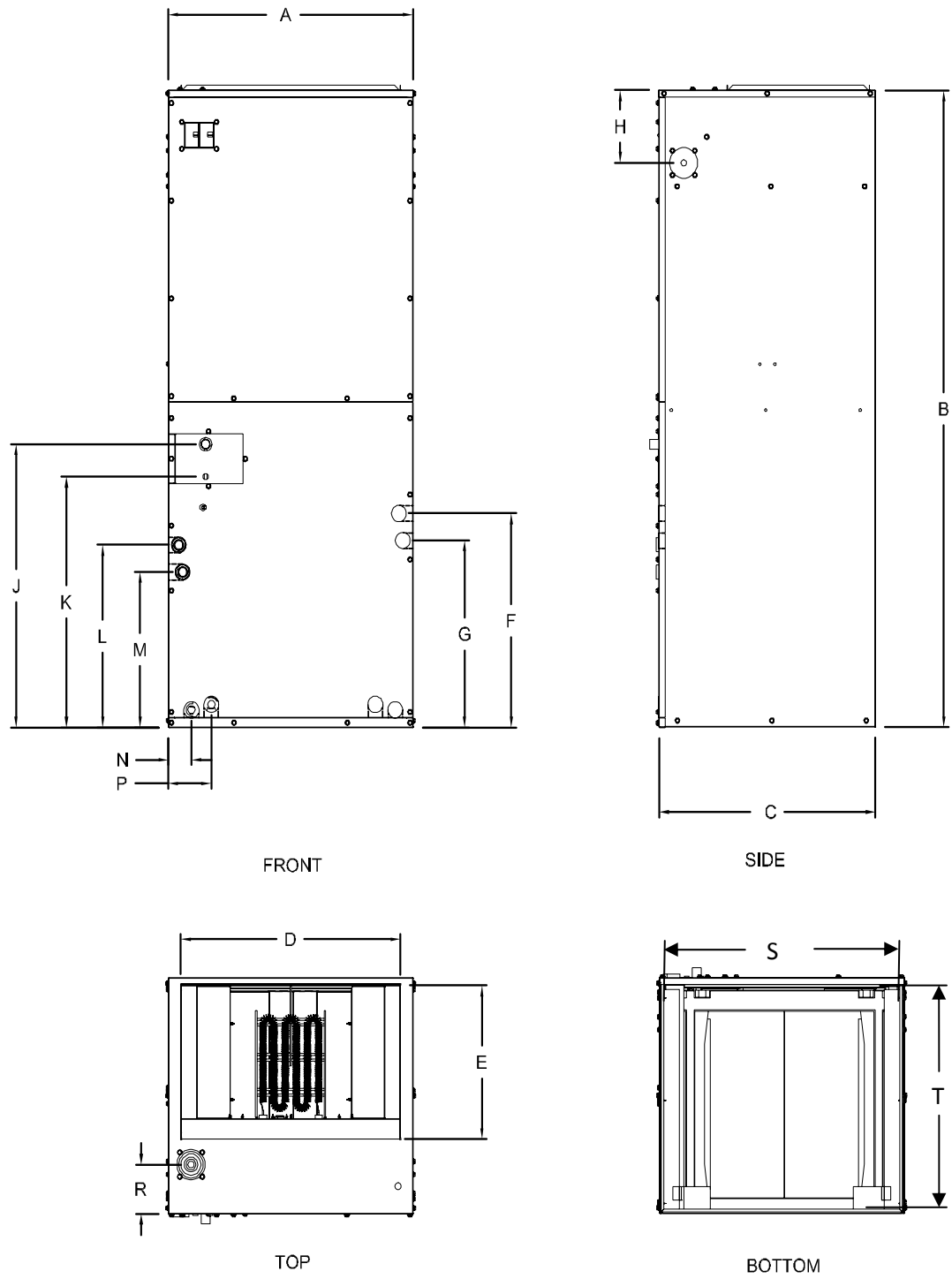

Figure 1: DIMENSIONAL DATA DX COOLING WITH OR WITHOUT ELECTRIC HEAT

DIMENSIONAL DATA MULTI-POSITION AIR HANDLER COOL ONLY OR ELECTRIC HEAT																	
Model	A	B	C	D	E	F	G	H	J	K	L	M	N	P	R	S	T
MS**18, 24	17.50	43.00	21.00	15.63	12.50	13.50	11.00	6.75	16.75	14.00	11.00	10.75	2.00	1.50	5.00	16.10	20.20
MS**25, 30, 36, 38, 46	21.00	48.00	21.00	19.00	12.50	14.50	13.00	6.75	20.00	17.00	12.75	10.30	2.30	4.35	5.00	19.90	20.80
MS**37, 42, 48, 60, 72	24.50	58.88	21.75	22.25	14.25	19.75	17.25	6.75	26.00	23.00	16.75	14.35	2.30	4.35	4.50	23.50	20.70

Table 2: DIMENSIONAL DATA DX COOLING WITH OR WITHOUT ELECTRIC HEAT

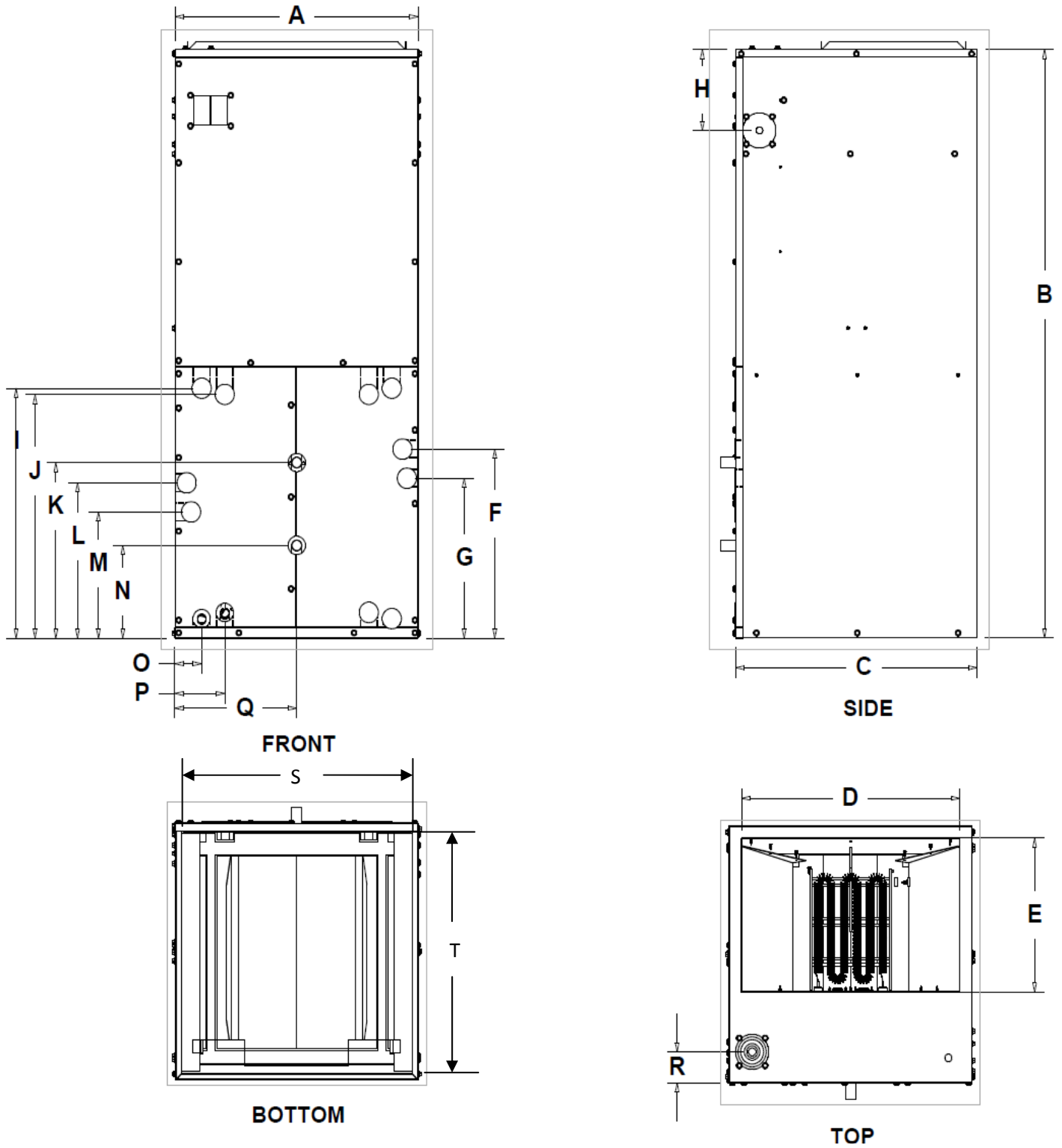

Figure 2: DIMENSIONAL DATA CHILLED WATER WITH AND WITHOUT ELECTRIC HEAT

Model	A	B	C	D	E	F	G	H	I	J	K	L	M	N	O	P	Q	R	S	T
MS**18,24	17.50	43.00	21.00	15.50	12.50	13.50	11.00	6.75	16.75	16.25	13.50	10.75	8.25	4.75	2.00	4.00	8.75	2.00	16.10	20.20
MS**25, 30, 36	21.00	48.00	21.00	19.00	12.50	15.50	13.00	6.75	20.25	19.75	14.25	12.75	10.25	7.50	2.25	4.25	10.50	2.50	19.90	20.80
MS**37, 42, 48, 60, 72	24.50	58.75	21.75	19.50	16.25	19.75	17.25	6.75	28.25	27.75	19.75	16.00	13.50	10.25	2.25	4.25	12.50	2.25	23.50	20.70

Table 3: DIMENSIONAL DATA CHILLED WATER WITH AND WITHOUT ELECTRIC HEAT

Series	Motor Type	Unit Size Capacity in MBTU/H	Heating Configuration	Voltage	Evaporator Coil Configuration	Option Code
MS = Multi-position Single Piece MM = Multi-position Modular US = Upflow Single Piece UM = Upflow Modular PS = Standard PSC VT = Variable Speed X-13 VE = Variable Speed ECM						AA = Standard Configuration XX = Motor Program Code XX = Pre-Painted Grey Top & Front Embossed Galvanized XX = Standard Coil XX = 1" Insulation
Small Cabinet 18, 24, OS Medium Cabinet 25, 30, 36, OM Large Cabinet 37, 42, 48, 60, OL						862T= DX Coil Geometry and Metering Device. (Refer to Coil Nomenclature) 8K2N CW Coil Gepmetry (Refer to Coil Nomenclature)
00 = No Heat Models 05 = 5kW Electric Heat 10 = 10kW Electric Heat 15 = 15kW Electric Heat 20 = 20kW Electric Heat 2P = 2 Row HW Coil with Pump 3P = 3 Row HW Coil with Pump 4P = 4 Row HW Coil with Pump 2N = 2 Row HW Coil No Pump 3N = 3 Row HW Coil No Pump 4N = 4 Row HW Coil No Pump						A = 120 VAC, 1 PH, 50/60 HZ B = 208/230 VAC, 1 PH, 50/60 HZ Contact factory For Other Voltage Availability

Table 4: Air Handler Model Nomenclature

NOTES: OS = No Cooling Coil – Small Cabinet Model.
 OM = No Cooling Coil – Medium Cabinet Model.
 OL = No Cooling Coil – Large Cabinet Model.
 MS = Multiposition Single Piece Cabinet – DX or Chilled Water Cooling – Electric or Hot Water (HW) Heating.
 MM = Multiposition Modular “Heating Only”.
 US = Upflow Single Piece Cabinet – DX or Chilled Water Cooling – Electric or Hot Water Heating.
 UM = Upflow Modular “Heating Only”.

FILTER BASE ASSEMBLY KIT – FIELD INSTALLED

- 86ET0002 – 16”X 20” X 2” Small Cabinet
- 86ET0001 – 20” X 20” X 2” Medium Cabinet
- 86ET0003 – 20” X 24” X 2” Large Cabinet

SECTION III: CLEARANCE AND RETURN AIR REQUIREMENTS

LOCATION

Access for servicing is an important factor in the location of any air handler. Provide a minimum of 30 inches in front of the appliance for access to the control box, heating elements, water pump, blower and air filters. This access may be provided by a closet door or by locating the appliance so that a wall or partition is not less than 30 inches from the front access Panel Location is usually predetermined. Check with owner’s or dealer’s installation plans. If location has not been decided, consider the following in choosing a suitable location.

1. Select a location with adequate structural support, space for service access, clearance for return and supply duct connections.
2. Normal operating sound levels may be objectionable if the air handler is placed directly over or under some rooms such as bedrooms, study, etc.
3. Caution should be taken to locate the unit so that supply and return air ducts are about the same length causing even

air distribution of supply and return air to and from the living spaces.

4. Locate appliance where electrical supply wiring can be easily routed to main electrical panel and where electrical wiring will not be damaged.
5. Locate appliance where thermostat wiring can be easily routed to the thermostat and where the wiring will not be damaged.
6. Locate appliance where refrigerant lines can be easily routed from the evaporator coil to the condenser.
7. Locate the appliance where condensate lines can be easily routed to an available drain. Be sure to route condensate drain piping so as not to obstruct access to the air filter.
8. When the coil is installed in a draw-thru application it will create a negative pressure situation in the condensate drain system. To prevent condensate from being drawn into the blower it is recommended to trap the primary (Main) and secondary (Overflow) drain line. Refer to CONDENSATE DRAIN SYSTEM and Figure 12 in these instructions. If the secondary drain is not used, it must be capped.
9. The draw-thru design will cause exterior surface of cabinet to sweat when units is installed in a non-conditioned space

such as an attic or garage. Installer must provide protection such as full size auxiliary drain pan on all units installed in a non-conditioned space to prevent damage from condensation runoff.

Some states, cities and counties require additional insulation to be installed on the exterior casing of the air handler to prevent sweating. Refer to the state, city, county or local code for insulation requirement to be sure the installation is in compliance.

It is recommended that air handlers installed in non-conditioned spaces be insulated on the exterior of the entire cabinet, including the front access panel with one (1) inch thick fiberglass with the vapor barrier on the outside.

Appliance Clearances

This appliance is approved for zero (0) inches clearance to combustible material on any part of the air handler exterior casing and the inlet or outlet ducts providing NO electric heater is being used. There is a one (1) inch clearance on the supply plenum and supply air duct when an electric heater is installed in the appliance. Refer to Table 5 for clearance to combustibles information.

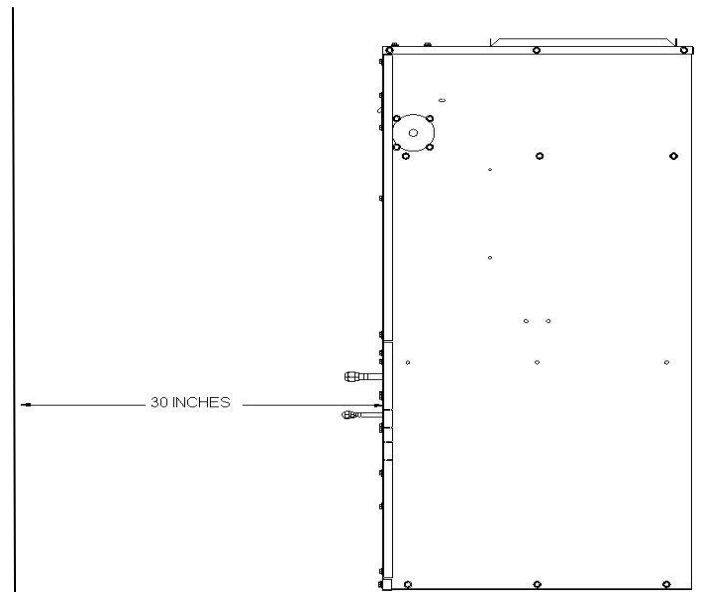

Figure 3: Clearance – Access for Service

MODEL	TOP (in)	BACK (in)	SIDES (in)	FRONT OF FURNACE		DUCT (in)
				ALCOVE (in)	CLOSET (in)	
Electric	0	0	0	30	6	1

Table 5: Clearances to Combustibles

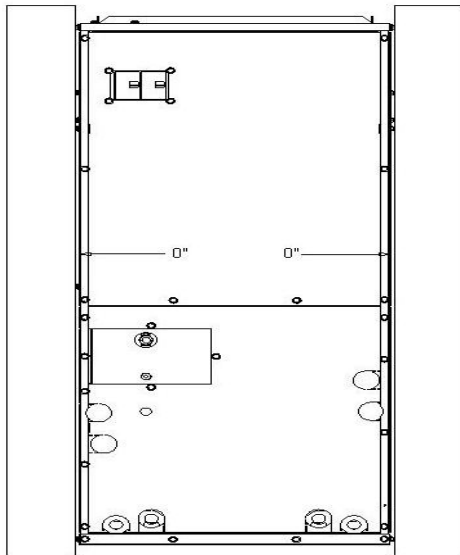

Figure 4: Closet Clearances

Return Air

In order for the air handler to work properly, a closet or alcove must have a certain total free area opening for the return air.

For A/C and HP Air Handlers 1/3 HP Blower Motor On (MSVE, MSVT, MSPS18 & 24)

- Minimum 200 in² free area opening
- Use Return Grille or Coil Cabinet

For A/C and HP Air Handlers 1/2 HP Blower Motors On (MSVE, MSVT, MSPS25, 30, & 36)

- Minimum 250 in² free area opening
- Use Return Grille, A/C Coil Cabinet, or any return grille with a minimum 250 in² free area opening

For A/C and HP Air Handlers with Electric Heat use 3/4 HP Blower Motor On (MSVE, MSVT, MSPS 37, 42, 48, & 60)

- Minimum 390 in² free area opening
- Use Return Grille, or A/C Coil Cabinet, or any return grille with a minimum 390 in² free area opening

For A/C and HP Air Handlers use 1.0 HP Blower Motor On (MSVE, MSVT72)

- Minimum 430 in² free area opening
- Use Return Grille, or A/C Coil Cabinet, or any return grille with a minimum 430 in² free area opening

Bottom Return Only – Recommended Grille Size

- 800 CFM – 20 X 20 Grille – 324 in²
- 1000 CFM – 20 X 25 Grille - 414 in²
- 1200 CFM – 25 X 25 Grille - 414 in²
- 1400 CFM – 25 X 30 Grille - 644 in²
- 1600 CFM – 25 X 30 Grille - 644 in²
- 1800 CFM – 30 X 30 Grille - 784 in²
- 2000 CFM – 30 X 35 Grille - 924 in²
- 2400 CFM – 30 X 40 Grille - 1064 in²

The return air opening can be located in the floor, on a closet front door or in a side wall above the furnace casing. If opening for the return air is located in the floor, side walls, or closet door anywhere below the appliance casing, a 6 inch minimum clearance between the appliance and the wall or door must be provided on the side where the return is located to provide for proper air flow. The 6 inch minimum clearance is not required if there is a return grille installed above the appliance casing, providing the grille has a sufficient return air opening.

SECTION IV: FURNACE & SUPPLY AIR DUCT INSTALLATION

ARRANGEMENT:

Unit is shipped from the factory arranged to be installed in an upflow or horizontal right to left air flow position. Horizontal right to left means, when facing the front of the unit, when the unit is laid on its side, the supply air opening is to the left and the return opening is to the right. These models are field convertible to a horizontal left to right air flow position

UPFLOW APPLICATION:

In an upflow installation the discharge outlet is at the top. Care should be taken to insure unit is level to permit proper condensate drainage. Normal upflow installation will be in a closet or basement. If installed in a closet, the closet should have a platform framed in, that with an opening at the top of the platform centered in the closet that measure at least 12 inches in height. A filter frame and filter can be used that covers the opening and is sealed to prevent air by-passing the filter. A filter grille can be used that is located as described in RETURN AIR REQUIREMENTS. The minimum filter size is shown in the table below.

Standard Throw away Air Filter @ 300 ft/min or less

800 CFM	= 20 x 20 x 1
1000 CFM	= 20 x 25 x 1
1200 CFM	= 20 x 30 x 1
1400 CFM	= 25 x 30 x 1
1600 CFM	= 25 x 30 x 1
1800 CFM	= 30 x 30 x 1
2000 CFM	= 30 x 40 x 1 or two 30 x 20 x 1
2400 CFM	= 30 x 40 x 1 or two 30 x 20 x 1

Pleated Air Filter @ 500 ft/min or less

800 CFM	= 16 x 16 x 1
1000 CFM	= 18 x 20 x 1
1200 CFM	= 20 x 20 x 1
1400 CFM	= 20 x 20 x 1
1600 CFM	= 20 x 25 x 1
1800 CFM	= 20 x 30 x 1 or two 20 x 15 x 1
2000 CFM	= 20 x 30 x 1 or two 20 x 15 x 1
2400 CFM	= 25 x 30 x 1 or two 14 x 30 x 1

Pleated filters are not recommended for use with PSC Motors.

Another option is to use the SunTherm Filter Base Accessory Kit. This filter base is placed on the closet floor and secured with screws. The unit is placed on top of the filter base and secured to the base with screws. Use seal strip, tape or calking to seal between the unit and the base.

Connect the supply air outlet to a plenum to the top of the unit and secure it with screws. Use a Non-tape sealant such as mastic or an aerosol sealant to seal duct leakage.

If installed in a basement, run supply and return duct work in accordance with local codes. Use a Non-tape sealant such as mastic or an aerosol sealant to seal duct leakage.

HORIZONTAL APPLICATION

Horizontal applications will normally be used in an attic or crawl space. This type of installation requires supply air plenum or duct to be connected to the supply collar and a return air plenum or duct be attached to the unit inlet collar. The supply ducts will be connected to the supply air plenum and routed thru

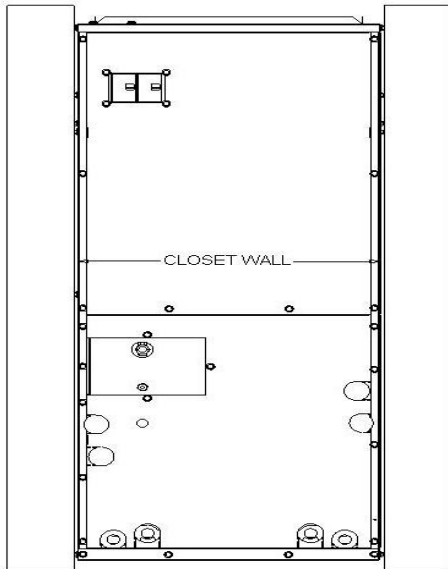

Figure 5: Typical Closet Installations

Provisions shall be made to permit the air in the rooms and the living spaces to return to the furnace. Failure to comply may cause a reduction in the amount of return air available to the blower, causing reduced air flow resulting in improper heating of the living space. The reduced air flow may cause the furnace to cycle on the limit causing premature heating element failure.

Upflow Accessory Filter Box Kit

Accessory filter box kit can be used on the return air end of the air handler when configured in the upflow position. The filter kit is placed over the return plenum in the floor and sealed to the plenum using sealant or caulking material and/or tape. The Air Handler is placed on top of the return filter box and the return opening sealed to prevent leaks.

Accessory filter box kit can be used on the return air end of the air handler when configured in the downflow position in place of a wall, door or ceiling mounted return filter grille.

NOTE: Make sure the flow arrow on the air filter is pointing towards the coil.

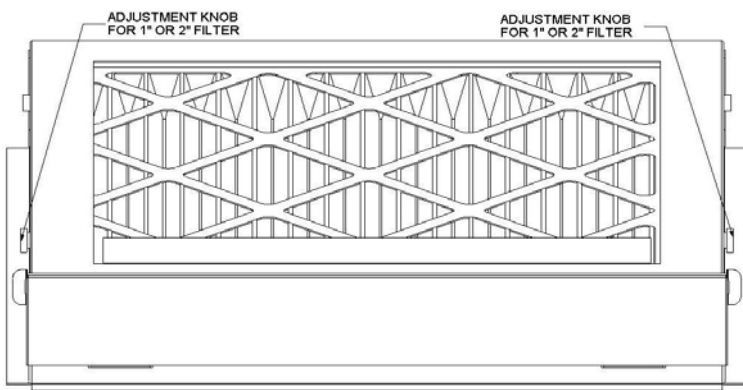

Figure 6: Accessory Air Filter Box for 1" or 2" Air Filters. Filter Size Adjustment knob is on both sides.

the attic to a register in each room. Use a Non-tape sealant such as mastic or an aerosol sealant to prevent leaks in the ducts and the plenum.

The opposite end of the return air duct is attached to a return filter grille housing. The filter grille is usually located in a wall, just below the ceiling or the ceiling in a hallway. Use a Non-tape sealant such as mastic or an aerosol sealant to prevent leaks in the ducts and the plenum.

The unit is shipped to be installed without modification in a right to left configuration. See ARRANGEMENT for details.

For left to right applications

1. Remove the unit access panels.
2. Remove the cooling coil
3. Move the condensate drain pan to the right side.
4. Reinstall the cooling coil
5. Connect the condensate drains and refrigerant lines
6. Reinstall unit access panels.

DOWNFLOW APPLICATION:

The unit is designed to be converted to a downflow configuration. You must use the downflow conversion kit and follow the instructions below. Refer to Figures 7 and 8.

1. Remove the blower and control box access door.
2. Remove evaporator coil access door and discard it. The evaporator access door will not be re-used.
3. Remove evaporator coil assembly with drain pan by sliding out the front of the unit as shown in the Figure 7.
4. Remove 6 screws (3 on each side of unit), securing evaporator coil support rails. Refer to Figure 7.
5. Flip the unit so the top is not the bottom.
6. Re-install the evaporator coil support rails in the holes provided in the unit casing as shown in Figure 8. Use the six (6) screws that were removed in step 4 to secure the evaporator coil support rails to the unit casing.
7. Re-install the cooling coil in the upright position as shown in Figure 8.
8. Remove the new evaporator coil access door from the kit and install over the evaporator section as shown in Figure 8.
9. Re-install the blower and control box access door in the upside down position and secure with the screws that were removed in step 1.

Hydronic heat units cannot be used in the down flow position.

DOWNFLOW CONVERSION KIT:

DISASSEMBLY INSTRUCTIONS

1. Remove evaporator coil door and discard. The door cannot be used in the downflow configuration. Remove the new evaporator coil door from the conversion kit box.
2. Remove the evaporator coil assembly with the drain pan by sliding it out of the front of the unit as shown in Figure 8.
3. Remove the 6 screws (3 on each side of the unit) securing the evaporator coil rails. Unit is ready to be reassembled in the downflow configuration.

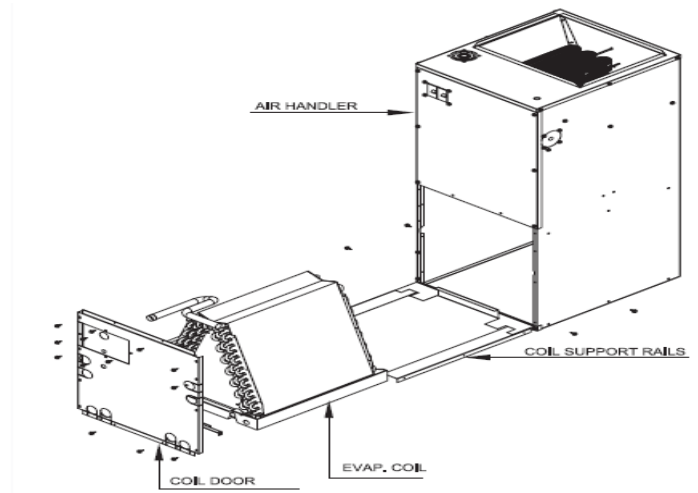

Figure 7: Evaporator Coil Disassembly for conversion to downflow.

ASSEMBLY INSTRUCTIONS

1. Invert the air handler 180° and reinstall the coil support rails, just above the blower. Use the six (6) screws that were removed in the disassembly instructions.
2. Slide the evaporator assembly back into the coil section. Evaporator must be installed so it is configured in the “A” position.
3. Install the new evaporator coil door that was removed from the kit..

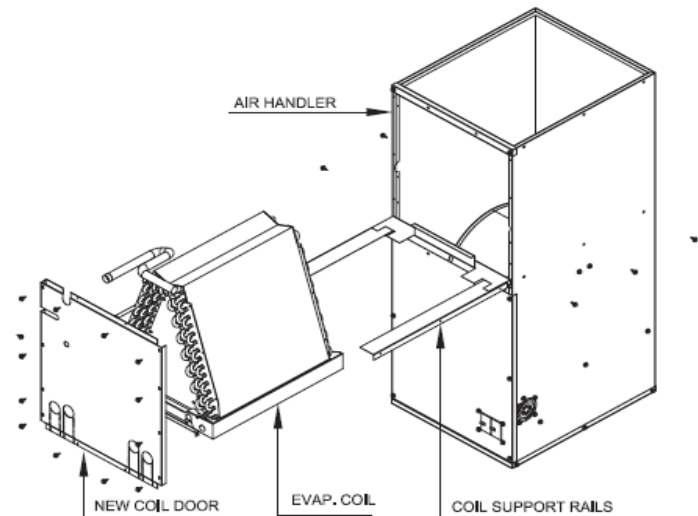

Figure 8: Evaporator Coil Assembly Converting to downflow operation.

INSTALLATION ON COMBUSTIBLE FLOORING

WARNING

Combustible Floor Base **MUST BE USED** when the unit is being installed on combustible flooring. The unit cannot be installed on carpeting.

Failure to use the combustible floor base combustible flooring or installing the unit on carpeting could result in a fire causing personnel injury, property damage or loss of life.

Before installing the combustible floor base make sure that there is a minimum of R-2.1 insulation between the sheet metal and any wood or combustible flooring. Refer to Figure 9 for typical combustible floor base installation.

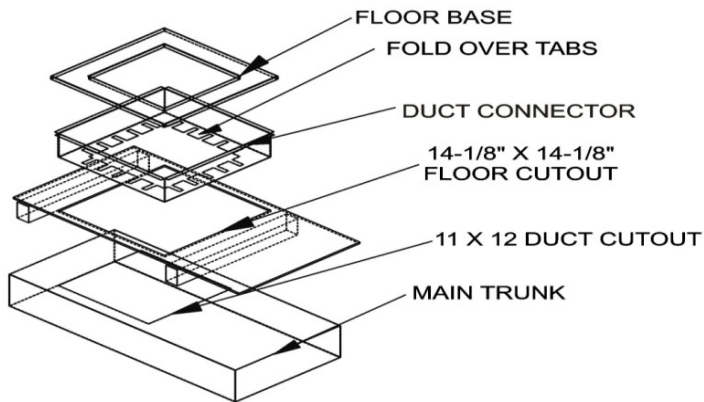

Figure 9: Combustible Floor Base Installation

SECTION V: FURNACE INSTALLATION

Installing the Air Handler

Closet Installation

Prior to installing the furnace make sure the holes are cut into the floor for the refrigerant tubing, the drain line, the electrical wiring, the thermostat wiring and the condenser control wiring.

1. Remove the top shipping cover and corner posts.
2. Remove the bottom shipping cover.
3. Remove the blower and control box access panel (door).
4. Remove the coil compartment access panel (door).
5. Place the unit into position using one of the following choices:
 - A. If the Combustible Floor Base is used you slide the unit on to the combustible floor base until the unit is touching the flanges on the back of the floor base.
 - B. If the Combustible Floor Base is not used you slide the unit over the duct opening until the opening in the unit lines up with the duct opening in the floor.
6. Secure the unit by one of the two choices:
 - A. If the Combustible Floor Base is used you secure the furnace to the floor by drilling two holes through the furnace base and the floor base at the right and left front inside corners of the cabinet. Use two screws to secure the furnace to the floor.
 - B. If the Combustible Floor Base is not used you secure the unit to the floor by drilling two holes through the furnace base at the left and right front inside corners of the cabinet. Use two screws to secure the unit to the floor.
7. Use calking, sealers, and/or tape to seal between the combustible floor base and the opening on the unit or between the opening on the unit and the duct in the floor.
8. Connect the electrical supply wires and the thermostat control wires in the control box.
9. Connect the refrigerant lines to the coil.
10. Re-install the coil compartment access panel (door) and secure with the screws that were removed in step 3.
11. Re-install the blower and control box access panel (door) and secure with the screws that were removed in step 2.
12. Turn the power on to the unit by following the procedure in the Users Information Manual.
13. Set the thermostat to the desired temperature.

SECTION VI: COOLING AND REFRIGERANT PIPING

DX Refrigerant Piping:

Air Handlers with DX type evaporator coils require liquid and suction piping sized in accordance with condensing unit manufacturer's instructions. The evaporator coils have sweat copper connections. Refrigerant lines should be soldered with silver solder or high temperature brazing alloy. Suction line must be insulated to avoid condensate from forming and dropping off. Armaflex (or equivalent) with 3/8" (1 cm) minimum wall thickness is recommended. In severe conditions such as hot or high humidity areas require 1/2" (1.3 cm) minimum wall thickness may be required. If condensing unit is installed above evaporator coil then oil traps are required at equal intervals along suction line (see Figure 5). Horizontal suction lines should slope 1 inch for every 20 feet toward condensing unit. Manufacturer recommends that dry nitrogen be flowed through refrigerant lines during soldering operation.

- Install 1 oil trap for a height difference of 15 ft to 25 ft (4.6 m to 7.6 m) between indoor and outdoor units.
- Install 2 oil traps for a height difference of 26 ft to 50 ft (7.9 m to 15.2 m) between indoor and outdoor units.
- Install 3 oil traps for a height difference of 51 ft to 100 ft (15.5 m to 30.5 m) between indoor and outdoor units.
- Install 4 oil traps for a height difference of 101 ft to 150 ft (30.8 m to 45.7 m) between indoor and outdoor units.

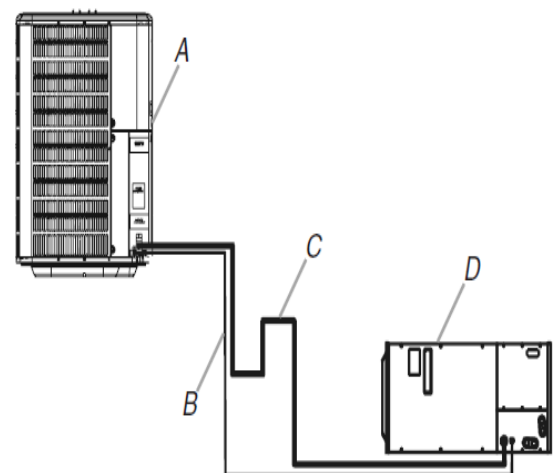

A. Condensing unit
B. Liquid line
C. Suction line
D. Evaporator coil

Figure 11 Evaporator Below Condenser Piping SPECIAL INSTRUCTIONS FOR COILS WITH THERMAL EXPANSION VALVES (TXV)

Thermal expansion valve (TXV) have a built in check valve making them A/C and heat pump capable. Hard start kit may be required on non-bleed TXV's. The external equalizer line attached to the TXV has a female flare nut with built in Schrader valve depressor that attaches to the Schrader valve port provided on coils.

A thermostatic expansion valve (TXV) is built around a thermostatic element separated from the valve body by a

diaphragm. Its purpose is to regulate the rate at which refrigerant flows into the evaporator.

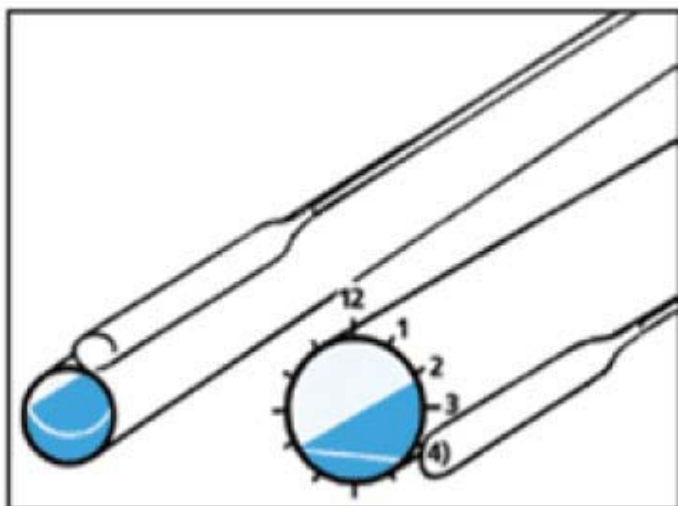

Figure 12: The TXV Bulb Best Placement

The bulb is best mounted on a horizontal suction line tube and in a position corresponding to between 1 o'clock and 4 o'clock. The location depends on the outside diameter of the tube. (Figure 6) .

Note: The bulb must never be located at the bottom of the suction line due to the possibility of oil laying in the bottom of the pipe causing false signals.

The bulb must be able to sense the temperature of the superheated suction vapor and must therefore not be located in a position that will expose it to extraneous heat/cold.

Be sure that the expansion valve provided is the proper size and type required to achieve rating. If a non-bleed type valve is to be used, the outdoor unit must be equipped with a hard start kit allowing the outdoor unit to start under load. Check with our factory if necessary.

How the TXV Controls Superheat

The thermostatic expansion valve (TXV) is a precision device designed to regulate the rate at which liquid refrigerant flows into the evaporator. This controlled flow is necessary to prevent the return of liquid refrigerant to the compressor.

The TXV separates the high pressure and low-pressure sides of a refrigeration or air conditioning system. Liquid refrigerant enters the valve under high pressure, but its pressure is reduced when the TXV limits the amount of refrigerant entering the evaporator.

Remember: the TXV controls only one thing: the rate of flow of liquid refrigerant into the evaporator. The TXV is not designed to control air temperature, head pressure, capacity, suction pressure, or humidity. Attempts to use the TXV to control any of these system variables will lead to poor system performance and possible compressor failure.

The TXV responds to the temperature of refrigerant gas as it leaves the evaporator. This temperature is detected by the sensing bulb, which is located near the evaporator outlet. The TXV also responds to the refrigerant pressure within the evaporator, which is transmitted to the TXV by an equalizer line. By responding to these variables, the TXV maintains a

predetermined superheat within the evaporator. This is how the TXV keeps the system in balance and operating properly. To understand how this works, we must have a clear understanding of superheat.

The TXV controls superheat by controlling the flow of liquid refrigerant. As it does this, it also reduces refrigerant pressure. Liquid refrigerant enters the TXV under high pressure. As the flow of liquid refrigerant is reduced, its pressure drops. The refrigerant leaving the TXV is now a combination of low-pressure liquid and vapor.

As the flow is restricted, several things happen:

- The pressure on the liquid refrigerant drops;
- A small amount of the liquid refrigerant is converted to gas, in response to the drop in pressure;
- This "flash gas" represents a high degree of energy transfer, as the sensible heat of the refrigerant is converted to latent heat;
- The low-pressure liquid and vapor combination moves into the evaporator, where the rest of the liquid refrigerant "boils off" into its gaseous state as it absorbs heat from its surroundings.

Changes in gas temperature at the evaporator outlet are detected by the sensing bulb, which then causes the valve pin to move in or out, regulating the flow of refrigerant through the TXV. In this way, the valve allows just enough refrigerant into the evaporator, to maintain the correct level of superheat in the suction line.

The TXV controls superheat by varying the size of the orifice through which the refrigerant flows. The pin angle, the size of the stroke (typically 0.015- to 0.035-in.) and the diameter of the orifice itself all affect how much refrigerant can pass through the valve. In addition, all valves have some leakage around the valve pin, although this is normally kept within acceptable limits.

It's important to remember that valve capacity is a function of the orifice diameter, pin angle, and stroke. Adjusting the superheat spring doesn't change valve capacity.

Trouble Shooting:

The thermostatic expansion valve (TXV) is like the carburetor in your car's engine. It opens and closes to allow the correct amount of refrigerant into your system. When the TXV isn't working properly, the efficiency of your unit is crippled. If you suspect you have a faulty TXV, perform these tests:

First, connect your gauges to the system and check that the refrigerant pressures, subcooling and superheat are where they should be (for pressures settings, refer to unit's pressure chart; for subcooling (usually around 10°F) and superheat (between 8°F-12°F) follow manufacturer's specification sheet.

Check to see if airflow through the system is good . There should be no dirty coils or air filters. Also check for proper CFMs readings across the system.

Make sure there's the right amount of refrigerant charge in the system (this step may require weighing out the refrigerant in the system). Once you've added or removed charge as necessary, check the pressures, subcooling and superheat again. If there is no change then it is probably the TXV.

Check the evaporator coil and remove the TXV's sensing bulb from the suction line.

Check the subcooling, superheat and pressures again. If there's no change, that's a further indication of a TXV problem. Another test is to put the sensing bulb in ice water and checking the pressures, superheat, and subcooling again. If they don't change, it's a bad TXV.

When a non-bleed expansion valve (TXV) is specified in a Summit AC or HP Rating, the following assumptions are made:

- a) The TXV is a field or factory installed accessory to be field or factory installed in accordance with recommended TXV practice.
- b) The combination of this non-bleed valve and the compressor in the outdoor unit results in a system that operates with a loaded condition on startup.
- c) The outdoor unit is capable of starting against this loaded condition or a hard start kit is to be field installed.

APPLICATION DATA:

R72DB0005 (R-22) 15% Bleed Non-Adjustable - 1.5-3.0 Ton
"T" Valve Letter Code

R72DB0003 (R-410A) 15%-Bleed Non-Adjustable-1.5–2.5 Ton
"D" Valve Letter Code

R72DB0004 (R-410A) 15%-Bleed Non-Adjustable-3.0–5.0 Ton
"Y" Valve Letter Code

Inlet Fitting Male Rotalock / Outlet Fitting Female swivel nut.

R72DB0006 (R-22) 15% Bleed Non-Adjustable - 3.0-5.0 Ton
"X" Valve Letter Code

R72DB0044 (R-410A) Non-Bleed Adjustable - 3.0-6.0 Ton
"Z" Valve Letter Code

Inlet Fitting Male Rotalock / Outlet Fitting Female swivel nut.

TXV TROUBLE SHOOTING:

Changing parts might be the first reaction, BUT...

1. May not be necessary and...
2. Does not always solve the problem.

SUPERHEAT AND SUCTION PRESSURE

LOW SUCTION PRESSURE – HIGH SUPERHEAT

POSSIBLE CAUSES:

1. Undersized valve
2. High superheat adjustment
3. Evaporator pressure drop – no external equalizer
4. External equalizer location – needs to be located on suction line after the last feeder tube.
5. Restricted or capped external equalizer
6. Low refrigerant charge
7. Plugged dryer or strainer
8. Low pressure drop across valve:
 - a. Plugged dryer or strainer
 - b. Low condensing temperature

HIGH SUCTION PRESSURE – LOW SUPERHEAT

POSSIBLE CAUSES:

1. Oversized valve
2. TXV seat leak
3. Low superheat adjustment
4. Bulb installation:
 - a. Poor thermal contact

- b. Warm location
5. Bad compressor – low capacity
6. Incorrectly located external equalizer line – needs to be located on suction line after the last feeder tube.

LOW SUCTION PRESSURE – LOW SUPERHEAT POSSIBLE CAUSES:

1. Low load:
 - a. Not enough air
 - b. Dirty air filters
 - c. Air too cold
 - d. Coil icing or frosting
2. Poor air distribution
3. Improper compressor evaporator balance – coil too big or small or incorrect balance on heat pump systems.
4. Oil is trapped in the evaporator

Check these things before removing the TXV

1. Remove the sensing bulb and hold in your hand. The high side pressure should drop and low side pressure should increase as the TXV opens.
2. Loosen the flare nut on the TXV external equalizer tube that is connected with a flare nut on the suction line. If you get a lot of pressure when the nut has been loosened then tighten the nut. If you get a slight pressure or no pressure; the Schrader valve stem is not being depressed. Install an anti blow back fitting to the external equalizer line of the TXV to depress the Schrader valve stem and check for proper operation of the TXV.

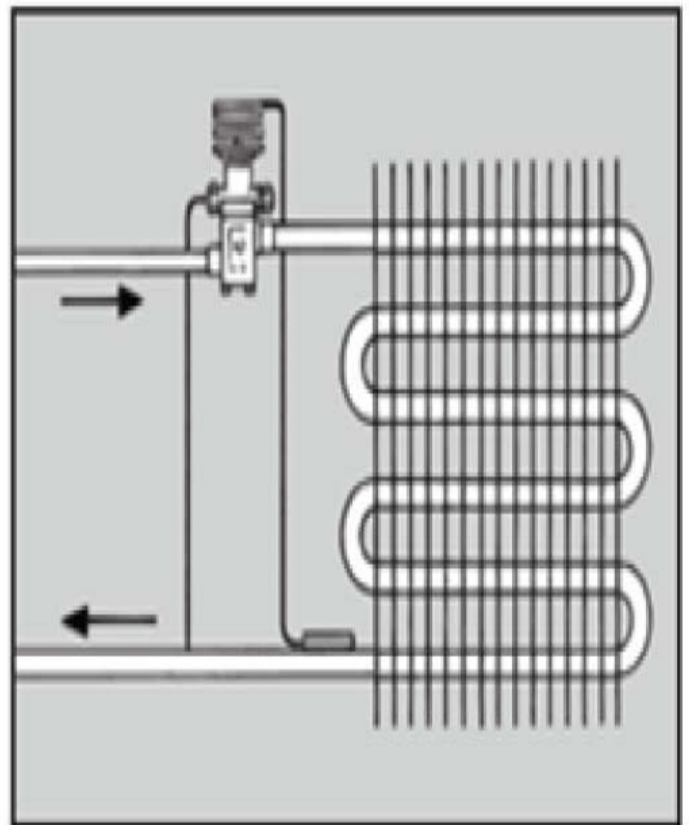

Figure 13: TXV Sensing Bulb Location

INSTALLATION NOTES:

With reference to the Figure 7, the TXV assembly is to be installed between the distributor and the existing liquid line

⚠ WARNING

Coil is pressurized with nitrogen. Relieve pressure before installing TXV by depressing Schrader valve on coil manifold.

Field Installed :

1. After coil pressure has been relieved, turn the female swivel nut counter-clockwise to remove.
2. If Flowrator Distributor Assembly is being replaced by a TXV, remove the piston orifice from the flowrator distributor assembly using a small diameter wire or paper clip.
3. Attach the TXV by connecting the female swivel nut on TXV outlet to the flowrator distributor (aligning Teflon seal first) and **torque swivel nut to 10-30 ft. lbs.**
4. Attach liquid line with female swivel nut to male rotalock fitting on TXV inlet (Aligning Teflon seal first) and **torque swivel nut to 10-30 ft. lbs.**
5. Remove the cap on Schrader valve port on coil manifold. Attach equalizer tubing with 1/4" female flare nut that includes depressor to this male Schrader port. **Torque nut to 10-30 ft. lb**
6. Install the TXV bulb to the suction manifold of coil or the suction line using the two bulb clamps furnished with kit.
 - a. Bulb should be installed on a horizontal run of the manifold if possible. On line less than 7/8" OD the bulb may be installed on top of the line. With 7/8" OD and over, the bulb should be installed in a position at about 4 or 8 o'clock.
 - b. If bulb installation is made on a vertical run, the bulb should be located at least 6 inches from any bend, and on the tubing side opposite the plane of the bend. On vertical bulb installations, the bulb should be positioned with the bulb capillary tube at the top.
 - c. The bulb should be insulated using thermal insulation to protect it from the effect of the surrounding ambient temperature.
7. After completing installation of TXV (including equalizer tube), it will be necessary to leak check the coil and evacuate the coil through the service access fittings of liquid and suction line valves.

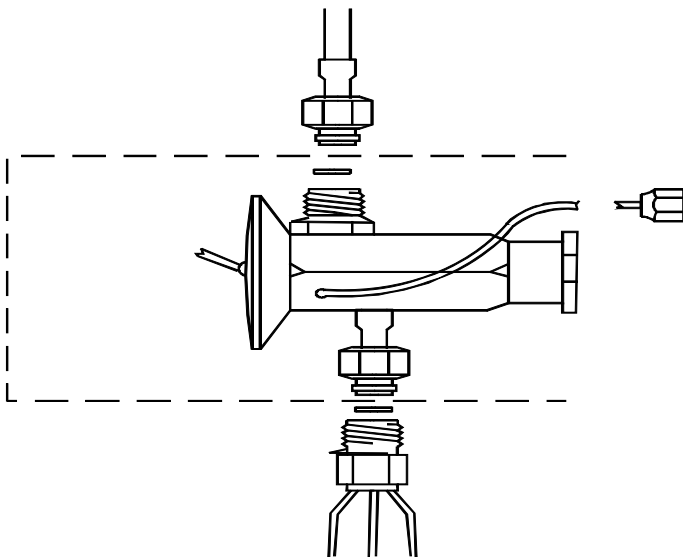

Figure 14 Typical TXV Connections

SPECIAL INSTRUCTIONS FOR COILS WITH FLOWRATOR DISTRIBUTOR ASSEMBLIES

The sizing of the orifice piston should be based strictly on the rated capacity of the outdoor unit and coil match.

Summit provides capacity performance ratings that match both same size and upsized coils with specific manufacturer's outdoor units. At the Summit distributor's request, the orifice piston is selected and installed in each coil for the specific range of cooling capacities likely to be encountered. The factory installed orifice piston size is marked on the flowrator distributor assembly and on the front of the coil carton.

When using this coil with an outdoor unit of another capacity, select an orifice piston from the table below if the capacity range for the coil and outdoor unit to be used differs.

Failure to install the proper orifice piston can lead to poor system performance and possible compressor damage. A variation of one piston size is not normally critical. Summit reserves the right to substitute a factory installed piston one size smaller or greater if the piston size ordered is out of stock.

A selection of replacement orifice pistons is available from your Summit supplier.

FLOWRATOR TO TXV CONVERSION:

While thermal expansion valves can be factory installed, they are normally available in kit form for field installation. For kit version, follow the installation instructions provided with the kit. Normally these can be field installed before system is charged without requiring cutting and brazing. **BE SURE FLOWRATOR PISTON HAS BEEN REMOVED FROM THE FLOWRATOR DISTRIBUTOR BODY PRIOR TO INSTALLATION OF EXPANSION VALVE.**

ORIFICE PISTON REPLACEMENT:

If the flowrator distributor assembly is being used the piston is to be installed as shown in Figure 9 in the distributor body then the existing liquid line attached to the flowrator distributor.

1. After coil pressure has been relieved, turn the female swivel nut counter-clockwise to remove.
2. Remove the piston from the flowrator distributor fitting using a small diameter wire or paper clip. **ALWAYS REMOVE PISTON FROM DISTRIBUTOR BODY WHEN TXV IS INSTALLED).**
3. Replace the orifice piston with the correct piston for the coil you are using. Make sure the tapered end of the piston is facing the feeder tubes on the distributor body.
4. **Turn the female swivel nut on clockwise the flowrator distributor (aligning Teflon seal first) and torque swivel nut to 10-30 ft. lbs.**
5. After completing the replacement of the orifice piston, it will be necessary to leak check the coil and evacuate the coil through the service access fittings of liquid and suction line valves.

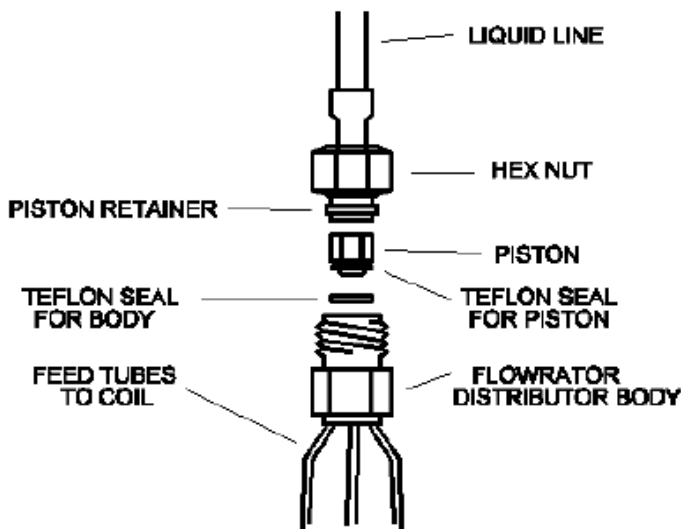

Figure 15: Flowrator Distributor

WARNING

Air handler must be located so that if any connections should leak, water will not cause damage to the adjacent area. When such locations can't be avoided, a suitable drain pan should be installed under the air handler, not over 1-1/2" deep, with minimum length and width at least 2" greater than the air handler dimensions and connected to an adequate drain. Under no circumstances is the manufacturer to be held liable for any water damage in connection with this air handler.

CONDENSATE DRAIN PIPING:

The air handler "A" coil drain pan has two 3/4" NPT female primary and two secondary connections (left or right hand). Horizontal pan has two 3/4" NPT female, one primary and one secondary. Piping from each fitting used is to have 1-1/2 minimum trap and each run in such a manner as to provide enough slope for adequate drainage to a visible area. Do not pipe these two fittings together into a common drain. Cap unused connection.

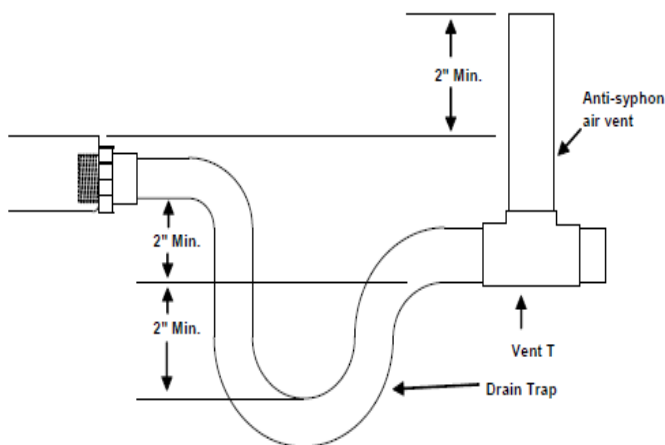

Figure 14: Typical Condensate Traps

SECTION VII: LINE VOLTAGE WIRING

Power Supply Wiring

The unit internal wiring is complete except for the power supply and the thermostat wires. See wiring diagram and/or Tables 6-9 for wire size, fuse/circuit breaker size, and ground wire sizes. The use of cable connectors on incoming power supply wires to relieve any strain on wiring is recommended. Follow the steps below to connect the power supply wires.

Single Circuit Line Wiring Connections

1. Remove the blower and control box access panel (door).
2. Remove the control box cover.
3. Install the cable connectors on the 7/8" dia holes on the right side of the control box.
4. Strip 1/2" of the insulation on the end of each wire.
5. Insert the wires through the holes in the casing and through the cable connectors.
6. Insert the black wire into the L1 screw terminal on the first circuit breaker from the top and tighten the set screw to clamp down on the wire.
7. Insert the white or red wire into the L2 screw terminal on the first circuit breaker down from the top and tighten the set screw to clamp down on the wire.
8. If you are using a single circuit for a 5 kW, 10kW, 15kW or 20kW model you will need to install a black jumper wire from the L1 terminal on circuit breaker #1 to the L1 terminal on circuit breaker #2 and a white or red jumper wire from the L2 terminal on circuit breaker #1 to the L2 terminal on circuit breaker #2. Refer to Figures 13, 14, 15, 16 and 17 for circuit breaker locations.
Note: The 100 amp 4 Pole Jumper Bar Assembly part number 68BAE001 can be used in place of the jumper wires.
9. Insert the green wire into the ground lug and tighten the set screw.

Dual Circuit Line Wiring Connections: 15kW or 20kW Models

10. You will need to insert the black wire from the second power supply into the L1 screw terminal on the second circuit breaker down from the top and tighten the set screw to clamp down on the wire.
11. You will need to insert the white or red wire from the second power supply into the L2 screw terminal on the second circuit breaker down from the top and tighten the set screw to clamp down on the wire.
12. You will need to insert both green wires into the ground lug and tighten the set screw.
13. Tighten the screws on the cable connectors until the power supply wires are securely fastened to the connector.

NOTE: The furnaces are equipped with either one or two circuit breakers. These circuit breakers protect the wiring inside of the furnace in the event of a short circuit. Additionally, these breakers provide a means of disconnecting the power to the unit. The circuit breakers in the furnace are not meant to protect the branch circuit wiring between the furnace and the home's breaker panel. General wire and breaker sizes are shown in Tables 6-9. If sheathed cable is used, refer to NEC National Electrical Code (NFPA 70) or the Canadian Electrical Code, Part I (CSA C22.1) and local codes for additional requirements concerning supply circuit wiring. Electrical data can be found in Tables 6-9.

IMPORTANT - All installation on field wiring must be rated at 60°C or higher. Please refer to the wiring diagrams on the furnace or the tables this manual for more information.

The 15kW and 20kW models may be connected to a single or dual branch circuit.

IMPORTANT - Refer to the NEC National Electrical Code (NFPA 70) or the Canadian Electrical Code, Part I (CSA C22.1) and local codes for wiring material requirements.

	AIR HANDLER MODELS																	
	**VE18, 24			**VT 18, 24			**PS 18, 24			**VE25, 30, 36			**VT 25, 30, 36			**PS 25, 30, 36		
5 kW Heater Amps - 208/230 VAC	18.0/20.88			18.0/20.88			18.0/20.88			18.0/20.88			18.0/20.88			18.0/20.88		
10 kW Heater Amps - 208/230 VAC	36.1/41.66			36.1/41.66			36.1/41.66			36.1/41.66			36.1/41.66			36.1/41.66		
15 kW Heater Amps - 208/230 VAC	N/A			N/A			N/A			54.1/62.5			54.1/62.5			54.1/62.5		
Indoor Blower Type	ECM			X-13 (CTM)			PSC			ECM			X-13 (CTM)			PSC		
Indoor Blower Amps	0.78			0.72			2.00			2.03			1.66			3.00		
Heater - kW	5	10		5	10		5	10		5	10	15	5	10	15	5	10	15
Circuit Load - FLA - 230 VAC	21.66	42.44		21.60	42.38		22.88	43.66		22.91	43.69	64.53	22.54	43.32	64.16	23.88	44.66	65.50
Min. Wire Size (90°C)	#10	#6		#10	#6		#10	#6		#10	#6	#3	#10	#6	#4	#10	#6	#3
Minimum Wire Size (75°C)	#10	#6		#10	#6		#10	#6		#10	#6	#3	#10	#6	#4	#10	#6	#3
Minimum Wire Size (60°C)	#10	#4		#10	#4		#10	#4		#10	#4	#2	#10	#4	#3	#10	#4	#2
Ground Wire Size	*	*		*	*		*	*		*	*	*	*	*	*	*	*	*
Max Fuse Amps	30	60		30	60		30	60		30	60	90	30	60	80	30	60	90

Table 6: Wiring Requirements – 208/230 VAC Electric Heat 18-36 kBTU Models - Single Branch Circuit

15kW, and 20kW Two Stage models may have a dual or single power supply.

Single power supply will require circuit breaker jumper bar or a jumper wire.

+ Refer to the National Electrical Code Table 250-95 for Non-Sheathed Conductor Ground Wire.

* Ground conductor **must be the same size and temperature rating** as the other conductors listed in Tables 6.

** Model Series – MS, MM, US or UM

	AIR HANDLER MODELS																													
	**VE37, 42, 48, 60						**VE72						**VT37, 42, 48, 60						**VT72						**PS37, 42, 48, 60					
5 kW Heater Amps - 208/230 VAC	18.0/20.88						18.0/20.88						18.0/20.88						18.0/20.88						18.0/20.88					
10 kW Heater Amps - 208/230 VAC	36.1/41.66						36.1/41.66						36.1/41.66						36.1/41.66						36.1/41.66					
15 kW Heater Amps - 208/230 VAC	54.1/62.5						54.1/62.5						54.1/62.5						54.1/62.5						54.1/62.5					
20 kW Heater Amps - 208/230 VAC	72.2/83.33						72.2/83.33						72.2/83.33						72.2/83.33						72.2/83.33					
Indoor Blower Type	ECM						ECM						X-13 (CTM)						X-13 (CTM)						PSC					
Indoor Blower Amps	2.50						3.75						6.80						5.72						3.60					
Heater - kW	5	10	15	20			5	10	15	20			5	10	15	20			5	10	15	20			5	10	15	20		
Circuit Load - FLA - 230 VAC	23.3	44.2	65.0	85.8			24.6	45.4	66.3	87.1			27.6	48.5	69.3	90.1			26.6	47.4	68.2	89.1			24.4	45.3	66.1	86.9		
Min. Wire Size (90°C)	#10	#6	#3	#3	#8	#6	#3	#2	#10	#4	#3	#2	#10	#6	#3	#2	#10	#6	#3	#2	#10	#6	#3	#2	#10	#6	#3	#2		
Minimum Wire Size (75°C)	#10	#6	#3	#2	#8	#6	#3	#1	#10	#4	#3	#1	#10	#6	#3	#1	#10	#6	#3	#1	#10	#6	#3	#1	#10	#6	#3	#1		
Minimum Wire Size (60°C)	#10	#4	#2	N/A	#8	#4	#2	N/A	#10	#4	#2	N/A	#10	#4	#2	N/A	#10	#4	#2	N/A	#10	#4	#2	N/A	#10	#4	#2	N/A		
Ground Wire Size	*	*	*	*	*	*	*	*	*	*	*	*	*	*	*	*	*	*	*	*	*	*	*	*	*	*	*	*		
Max Fuse Amps	30	60	90	110	35	60	90	125	35	70	90	125	35	60	90	125	35	60	90	125	35	60	90	125	35	60	90	125		

Table 7: Wiring Requirements – 208/230 VAC Electric Heat 37-60 kBTU Models - Single Branch Circuit

15kW, and 20kW Two Stage models may have a dual or single power supply. - Single power supply may require jumper bar or a jumper wire.

+ Refer to the National Electrical Code Table 250-95 for Non-Sheathed Conductor Ground Wire.

* Ground conductor **must be the same size and temperature rating** as the other conductors listed in Table 7.

** Model Series – MS, MM, US or UM

	AIR HANDLER MODELS																													
	**VE25, 30, 36						**VT 25, 30, 36						**PS 25, 30, 36						**VE37, 42, 48, 60, 72											
5 kW Heater Amps - 208/230 VAC	18.0/20.88						18.0/20.88						18.0/20.88						18.0/20.88											
10 kW Heater Amps - 208/230 VAC	36.1/41.66						36.1/41.66						36.1/41.66						36.1/41.66											
15 kW Heater Amps - 208/230 VAC	18/20.8	38.1/41.7					18/20.8	38.1/41.7					18/20.8	38.1/41.7				18/20.8	38.1/41.7											
20 kW Heater Amps - 208/230 VAC	N/A						N/A						N/A						36.1/41.7											
Indoor Blower Type	ECM						X-13 (CTM)						PSC						ECM											
Indoor Blower Amps	2.03						1.66						3.00						2.50											
Heater - kW	5	10					5	10					5	10				5	10					5	10					
Circuit	1	1	1	2			1	1	1	2			1	1	1	2			1	1	1	2			1	1	1	2		
Circuit Load - FLA	22.9	43.7	43.7	20.8			22.5	43.3	43.3	20.8			23.9	44.7	44.7	20.8			23.3	44.2	44.2	20.8			44.2	20.8	44.2	41.7		
Min. Wire Size (90°C)	#10	#6	#6	#10	#10	#6	#6	#6	#10	#10	#6	#6	#10	#10	#6	#6	#10	#10	#10	#6	#6	#10	#6	#6	#10	#6	#6	#6		
Minimum Wire Size (75°C)	#10	#6	#6	#10	#10	#6	#6	#6	#10	#10	#6	#6	#10	#10	#6	#6	#10	#10	#10	#6	#6	#10	#6	#6	#10	#6	#6	#6		
Minimum Wire Size (60°C)	#10	#4	#4	#10	#10	#4	#4	#4	#10	#10	#4	#4	#10	#10	#4	#4	#10	#10	#10	#4	#4	#10	#4	#4	#10	#4	#4	#4		
Ground Wire Size	*	*	*	*	*	*	*	*	*	*	*	*	*	*	*	*	*	*	*	*	*	*	*	*	*	*	*	*	*	
Max Fuse Amps	30	60	60	30	30	60	60	30	30	60	60	30	30	60	60	30	30	60	60	30	30	60	60	60	30	60	60	60		

Table 8: Wiring Requirements – 208/230 VAC Electric Heat 25-60 kBTU Models – Dual Branch Circuit

15kW, and 20kW Two Stage models may have a dual or single power supply. - Single power supply may require jumper bar or a jumper wire.

+ Refer to the National Electrical Code Table 250-95 for Non-Sheathed Conductor Ground Wire.

* Ground conductor **must be the same size and temperature rating** as the other conductors listed in Table 8.

** Model Series – MS, MM, US or UM

	AIR HANDLER MODELS																							
	**VE72				**VT37, 42, 48, 60				**VT72				**PS37, 42, 48, 60											
5 kW Heater Amps - 208/230 VAC	18.0/20.88				18.0/20.88				18.0/20.88				18.0/20.88											
10 kW Heater Amps - 208/230 VAC	36.1/41.66				36.1/41.66				36.1/41.66				36.1/41.66											
Circuit Number	1		2		1		2		1		2		1		2									
15 kW Heater Amps - 208/230 VAC	18.0/20.8		38.1/41.7		18.0/20.8		38.1/41.7		18.0/20.8		38.1/41.7		18.0/20.8		38.1/41.7									
20 kW Heater Amps - 208/230 VAC	36.1/41.7		36.1/41.7		36.1/41.7		36.1/41.7		36.1/41.7		36.1/41.7		36.1/41.7		36.1/41.7									
Indoor Blower Type	ECM				X-13 (CTM)				X-13 (CTM)				PSC											
Indoor Blower Amps	3.75				6.80				5.72				3.60											
Heater - kW	5	10	15	20	5	10	15	20	5	10	15	20	5	10	15	20								
Circuit	1	1	1	2	1	2	1	1	1	2	1	2	1	1	1	2	1	1	1	2	1	2		
Circuit Load - FLA - 230 VAC	24.6	45.4	45.4	20.8	45.4	41.7	27.6	48.5	48.5	20.8	48.5	41.7	26.6	47.4	47.4	20.8	47.4	41.7	24.4	45.3	45.3	20.8	45.3	41.7
Min. Wire Size (90°C)	#8	#6	#6	#10	#6	#6	#8	#4	#6	#10	#6	#6	#10	#6	#6	#10	#6	#6	#8	#6	#6	#10	#6	#6
Minimum Wire Size (75°C)	#8	#6	#6	#10	#6	#6	#8	#4	#4	#10	#4	#6	#10	#6	#6	#10	#6	#6	#8	#6	#6	#10	#6	#6
Minimum Wire Size (60°C)	#8	#4	#4	#10	#4	#4	#8	#4	#4	#10	#4	#4	#10	#4	#4	#10	#4	#4	#8	#4	#4	#10	#4	#4
Ground Wire Size	*	*	*		*	*	*	*	*	*	*	*	*	*	*	*	*	*	*	*	*	*	*	*
Max Fuse Amps	35	60	60	30	60	60	35	70	70	30	70	60	35	60	60	30	60	60	35	60	60	30	60	60

Table 9: Wiring Requirements – 208/240 VAC Electric Heat 37-72 kBTU Models – Dual Branch Circuit

15kW, and 20kW Two Stage models may have a dual or single power supply. - Single power supply may require jumper bar or a jumper wire.

+ Refer to the National Electrical Code Table 250-95 for Non-Sheathed Conductor Ground Wire.

* Ground conductor **must be the same size and temperature rating** as the other conductors listed in Table 9.

** Model Series – MS, MM, US or UM

	BRANCH CIRCUIT	ELECTRIC HEATER SIZES							
		5 kW		10 kW		15 kW		20 kW	
		1	2	1	2	1	2	1	2
240 VAC, 60 HZ, 1 PH	BTU	17,033	34,067	34,067	17,033	34,067	34,067	17,033	34,067
	kW	4.99	10	10	4.99	10	10	4.99	10
230 VAC, 60 HZ, 1 PH	BTU	15,876	33,686	33,686	15,876	33,686	33,686	15,876	33,686
	kW	4.65	9.78	9.78	4.65	9.78	9.78	4.65	9.78
220 VAC, 60 HZ, 1 PH	BTU	14,736	30,222	30,222	14,736	30,222	30,222	14,736	30,222
	kW	4.3186	8.8572	8.8572	4.3186	8.8572	8.8572	4.3186	8.8572
Heating Element Capacity	BTU	17,033	34,067	51,149		68,232			
	kW	4.99	9.9984	14.9904		19.9968			

Table 10: Electric Heater Electrical Data

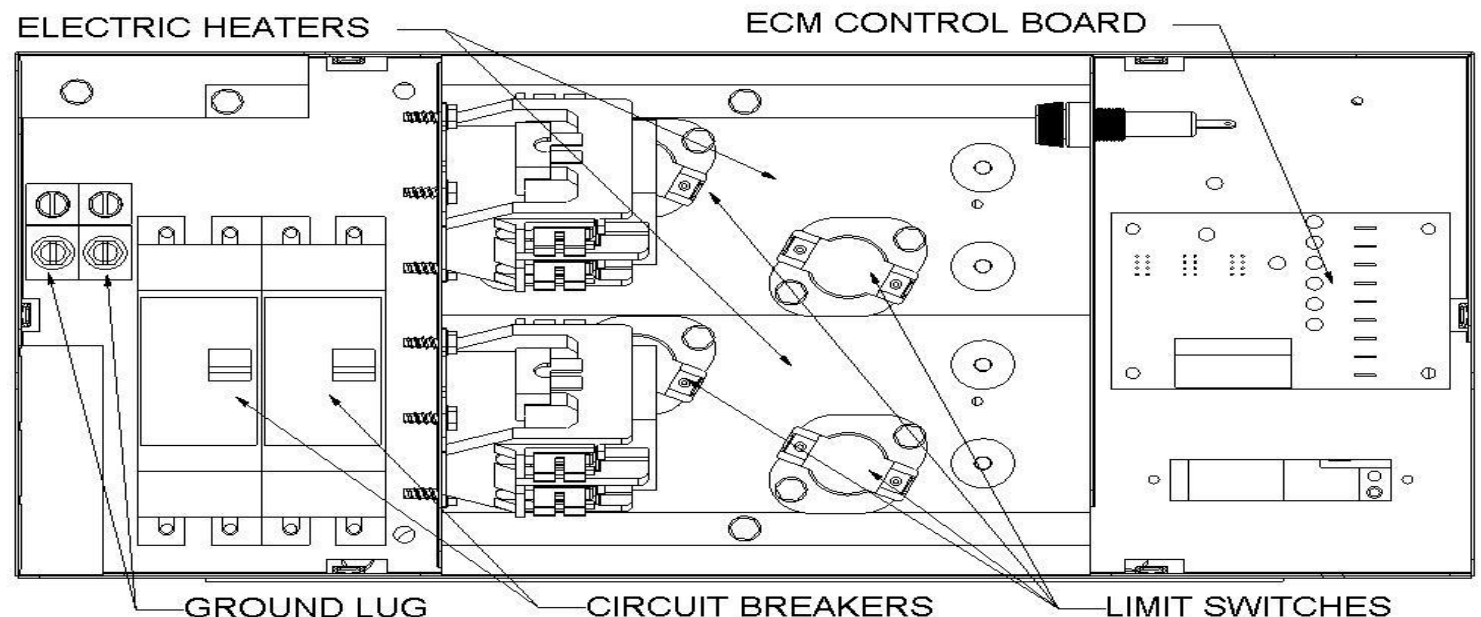

Figure 15: Component Locations – Electric Heat Control Box

Casing or cabinet must be permanently grounded in accordance with the National Electrical Code or other applicable codes.

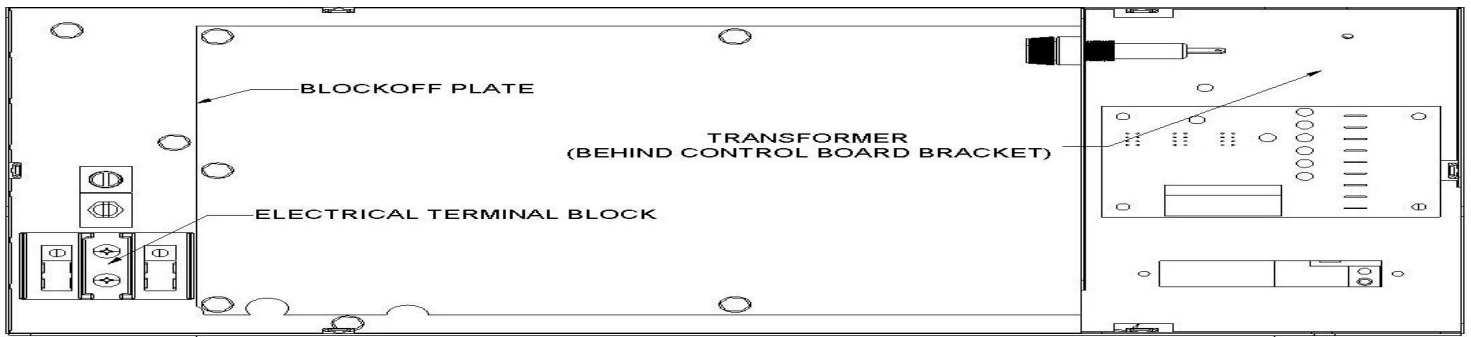

Figure 16: Component Locations – No Heat Control Box

⚠ WARNING

For personal safety be sure to turn the electrical power “OFF” at the main entrance (Home Circuit Breaker Box) and at the unit control box circuit breakers before attempting any service or maintenance operations. Homeowners should never attempt to perform any maintenance which requires opening the air handler control box door. Refer to Figure 16.

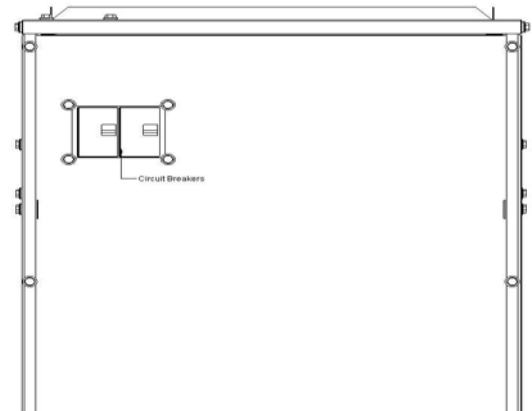

Figure 18: Circuit Breaker Front Panel Location

SECTION VIII: FIELD INSTALLED ELECTRIC HEATER KITS

This instruction covers the physical installation of the following electric heat kits on the MS,MM,US,UM series models. Refer to Tables 6 – 9 for electrical specifications.

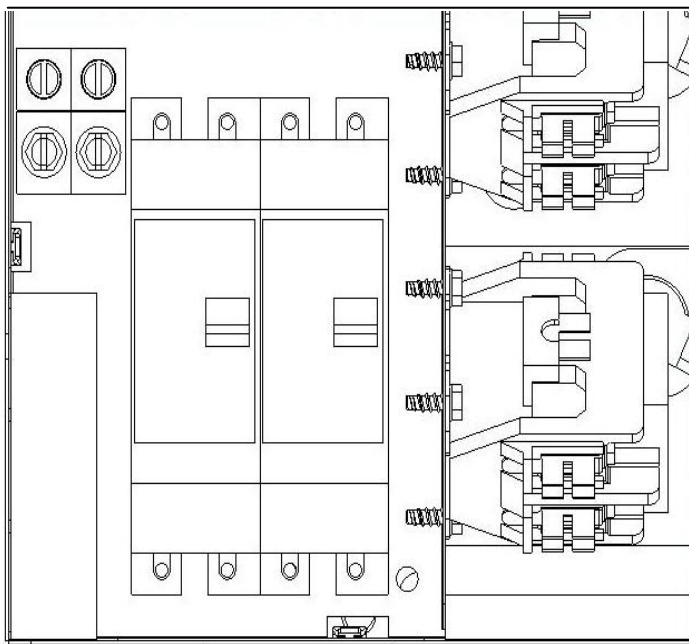

Figure 17: Control Box Circuit Breaker Location.

⚠ WARNING

This air handler is not equipped with a shield that covers the line voltage electrical supply wires and the circuit breaker connections. Take precautions to prevent accidental electrical shock. Be sure to turn the electrical power “OFF” at the main entrance (Home Circuit Breaker Box) and at the control box circuit breakers before removing the front panel. Refer to Figure 19 for drawing of the front panel circuit breaker location.

Models equipped with circuit breakers						
Model No	Cabinet Size	Voltage	Phase	Hertz	Heater kW	Motor
BSPHK05B	Small	208/240	1	60	5	PSC
BSPHK10B	Small	208/240	1	60	10	PSC
BMPHK05B	Medium	208/240	1	60	5	PSC
BMPHK10B	Medium	208/240	1	60	10	PSC
BMPHK15B	Medium	208/240	1	60	15	PSC
BLPHK05B	Large	208/240	1	60	5	PSC
BLPHK10B	Large	208/240	1	60	10	PSC
BLPHK15B	Large	208/240	1	60	15	PSC
BLPHK20B	Large	208/240	1	60	20	PSC
BSXHK05B	Small	208/240	1	60	5	X-13
BSXHK10B	Small	208/240	1	60	10	X-13
BMXHK05B	Medium	208/240	1	60	5	X-13
BMXHK10B	Medium	208/240	1	60	10	X-13
BMXHK15B	Medium	208/240	1	60	15	X-13
BLXHK05B	Large	208/240	1	60	5	X-13
BLXHK10B	Large	208/240	1	60	10	X-13
BLXHK15B	Large	208/240	1	60	15	X-13
BLXHK20B	Large	208/240	1	60	20	X-13
BSEHK05B	Small	208/240	1	60	5	ECM
BSEHK10B	Small	208/240	1	60	10	ECM
BMEHK05B	Medium	208/240	1	60	5	ECM
BMEHK10B	Medium	208/240	1	60	10	ECM
BMEHK15B	Medium	208/240	1	60	15	ECM
BLEHK05B	Large	208/240	1	60	5	ECM
BLEHK10B	Large	208/240	1	60	10	ECM
BLEHK15B	Large	208/240	1	60	15	ECM
BLEHK20B	Large	208/240	1	60	20	ECM

Table 11: Electric Heater Kit Model Numbers.

NOTE: All models have factory installed circuit breakers and electric heater kits have field installed circuit breakers. The models are MS, MM, US, UM are configured as follows: Small cabinet **VE18, 24 - **VT 18, 24 - **PS 18, 24 Medium cabinet **VE25, 30, 36 - **VT25, 30, 36 - **PS25, 30, 36.

Large cabinet **VE37, 42, 48, 60, 72 - **VT37, 42, 48, 60, 72 - **PS37, 42, 48, 60, 72.

The field installed electric heat accessories are used on cooling or heat pump models that were not purchased with electric heat from the factory. Each air handler model is approved for use with the field installed accessory electric heat kit.

INSTALLING THE HEATERS

1. Follow the instructions in the USERS INFORMATION MANUAL to properly shut down the air handler.
2. Remove the block off plate shown in Figure 14 and discard. Retain the screws, they will be used to secure the electric heater mount plate.
3. Insert electric heat kit into the opening where the block off plate was removed. Secure the mounting plate with the screws that were removed from the block off plate.
4. Connect the six pin male plug on the electric heater assembly to the six pin female plug mounted on the side of the low voltage control box divider panel.
5. Remove the wiring diagram from the kit, remove the paper that covers the adhesive back and place the electric heat wiring diagram over the wiring diagram located on the blower housing.
6. Follow the instructions in the USERS INFORMATION MANUAL to properly start up the air handler.



After installing the electric heater, a one inch clearance must be maintained on all sides of the supply air duct and/or plenum for a minimum of thirty six inches from the air handler discharge opening.

POWER SUPPLY CONNECTIONS

If the air handler has been installed prior to installing the electric heaters or if an older unit is being replaced, the supply power wires must be checked to make sure the wires are the proper sizes to handle the current load for the heaters Refer to Tables 6 thru 9 for correct wire size. If the supply power wire size is incorrect, new wires will need to be installed. Follow the instructions “Power Supply Wiring” on page 18 and 21 of these instructions for proper installation.

For circuit breaker models only - After the supply wiring has been connected to the circuit breakers you must remove the transformer and indoor blower motor wires from the terminal block as shown in Figure 14 and connect them to load side of circuit breaker #1.

LOW VOLTAGE CONNECTIONS

If the air handler was previously installed, nothing will need to change on the low voltage wiring. If this is a new installation refer to SECTION VII of these instructions.



To prevent damage, carefully insert the electric heating assembly through the rectangular opening in the front of the discharge opening so the heat element support rod is seated into the hole on the back side of the discharge opening.

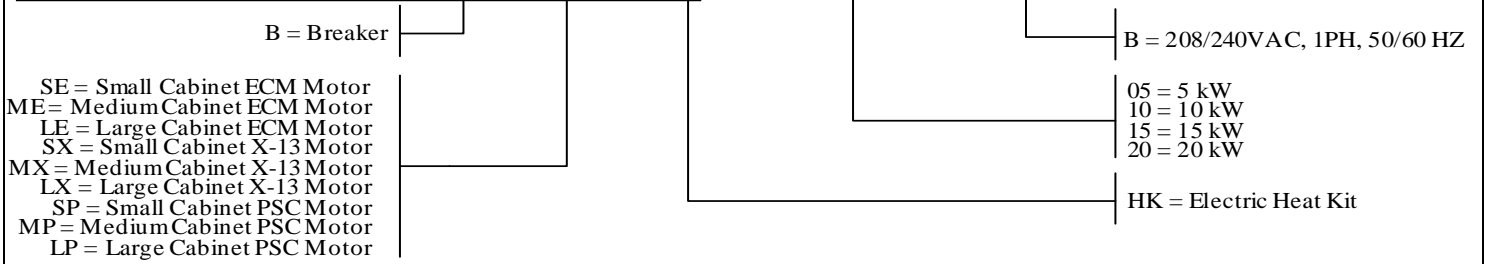

Table 12: Accessory Heater kit Nomenclature

SECTION IX: THERMOSTAT WIRING AND CONNECTIONS

Thermostat Wiring

Thermostat wires connect through side of furnace and should be no smaller than 22 gauge. Refer to Table 13 for recommended wire gauge, lengths and maximum current for each wire gauge.

Max. Thermostat Wire Length	Thermostat Wire Gauge	Thermostat Wire Maximum Current
0 - 100 Feet	22	3.0 Amps
0 - 125 Feet	20	3.0 amps
0 - 250 Feet	18	3.0 amps

Table 13: Low Voltage Wire Gauge and Max Lengths

Thermostat wires can enter through the side or top of the unit.

When bringing wiring through the top or side of the furnace, cable connectors must be installed to hold wiring in place and to relieve any strain on the wiring.

The use of a five-conductor cable from the thermostat to the furnace is recommended for typical heating or heating/cooling installations with a two or three-conductor cable from the furnace to the condenser. The thermostat wire colors and the typical heating/cooling connections are listed in Tables 14 and 15.

A seven-conductor cable from the thermostat to the furnace is recommended for a typical heat pump installation with a five-conductor cable from the furnace to the condenser.

The thermostat wire colors and the typical heat pump heating/cooling connections are listed in Tables 14 and 15.

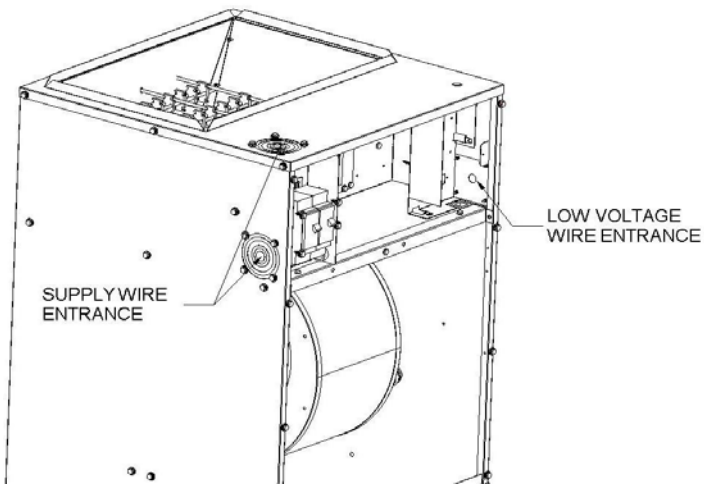

Figure 19: No Heat and Factory Installed Electric Heat Control Box

Thermostat Installation

The thermostat heat anticipator must be set at 0.4 Amps if the thermostat has a manual heat anticipator adjustment. This setting should be checked at the time of installation.

The thermostat may be a “self-setting” type in which case no heat anticipator setting will be found on the thermostat, eliminating the need for any field adjustment.

Thermostat should be located on an inside wall in an open area to more closely regulate average room air, preferably, where there is air movement back to furnace. Locating height of thermostat is important. Thermostat should be located preferably in a hall way upstream from the furnace return airflow, not within three feet of from any windows and 52 to 66 inches above the floor.

DO NOT place the thermostat within three feet of any of the furnace supply air registers

DO NOT place the thermostat within three feet of any of the air conditioner supply air registers

Maintenance, operating and/or programming instructions are in the envelope accompanying the thermostat. Give the envelope to the home owner.

CAUTION	
Do not locate thermostat within three feet of any of the following items:	
1	Furnace supply air registers
2	Cooling unit supply air registers
3	Lights or heat lamps
4	Aquariums
5	Televisions, stereo, amplifiers, surround sound systems
6	Stoves or any cooking appliance
7	Refrigerator
8	Washer and/or dryer
9	Hot water tank
10	Sink or near any hot water
11	Within 15 feet of any electric space heater
12	Within two feet of any sunlight

Separate Heating and Cooling System; Same Thermostat

If the furnace and the cooling unit have separate transformers be sure to use a thermostat with isolated heating and cooling contacts “RC” and “RH” to prevent interconnection of Class II

24 Volt Systems. Cycle furnace and the air conditioner separately to make sure it will operate correctly.

Most new thermostats have separate heating and cooling contacts for use with homes that have a air handler and air conditioner that are completely separate and each have a 24 VAC transformer for system control. These thermostats have a “RC” terminal for cooling and a “RH” terminal for heating. Connect the cooling unit red wire from the “R” terminal on the outdoor unit to the “RC” terminal on the thermostat and the RED air handler pigtail wire to the “RH” terminal on the thermostat. Refer to Figures 18 and 25 for typical low voltage wire connections.

If you have separate furnace and air conditioner with separate transformers and your thermostat does not have the “RC” and “RH” terminals it is recommended that you purchase a new thermostat. If the furnace and air conditioner are both connected to the thermostat “R” terminal it can cause transformer burnout or it can cause either the furnace or air conditioner control system to go into lockout.

Separate Heating and Cooling Units, Separate Thermostats

If the heating/cooling system in your house is a central heating and cooling system but, the furnace and the cooling unit are controlled by separate thermostats, then the use of a thermostat interlock switch is required in order to prevent the furnace and the air conditioner from operating at the same time.

CAUTION	
When using separate thermostats a thermostat interlock system must be provided to prevent simultaneous operation of the furnace and air conditioner. Simultaneous operation can result in equipment overheating, equipment damage, and wasted energy.	
Do Not connect the Yellow wire to the thermostat unless an outdoor unit is installed.	

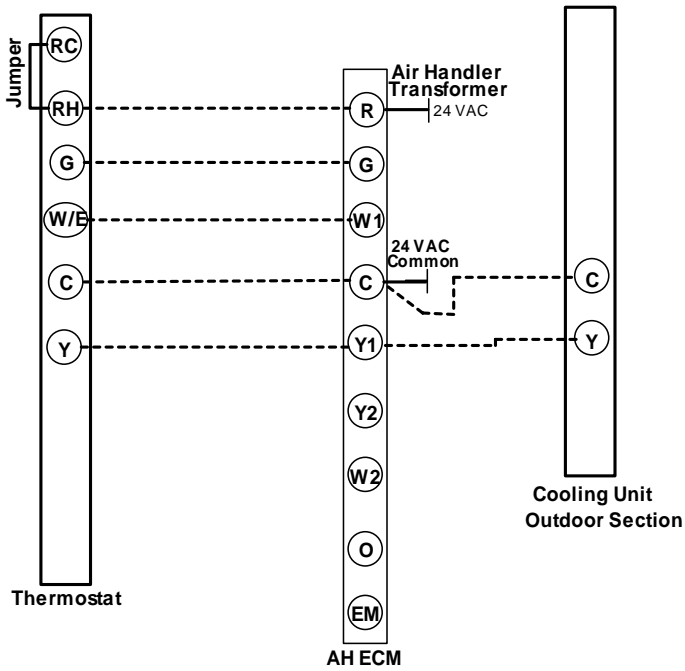

Figure 20: Typical Single Stage Heat with Single Stage Split System Cooling

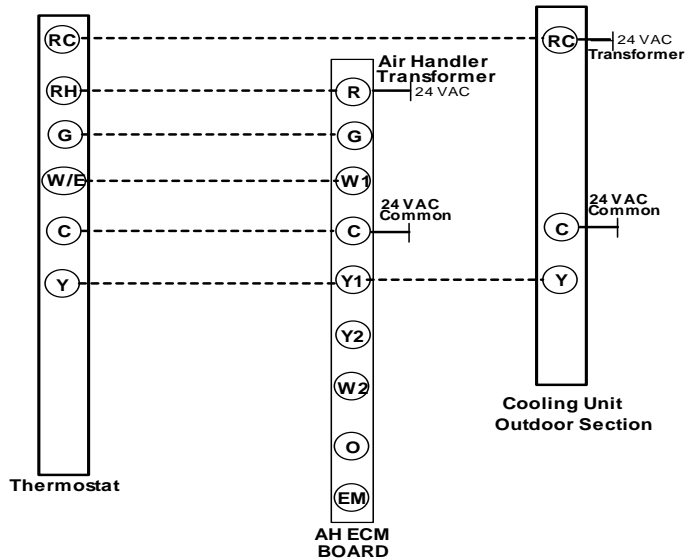

Figure 21 Typical Single Stage Heat with Single Stage Package Cooling Unit

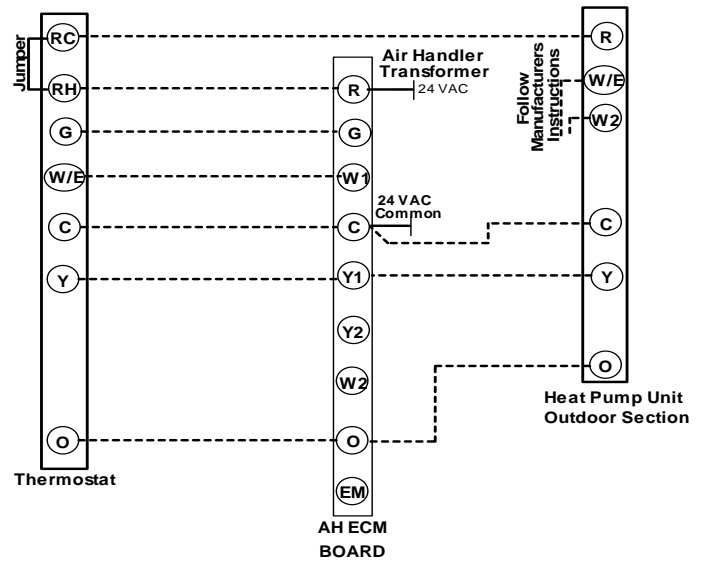

Figure 22: Typical Single Stage Heat with Single Stage Split System Heat Pump

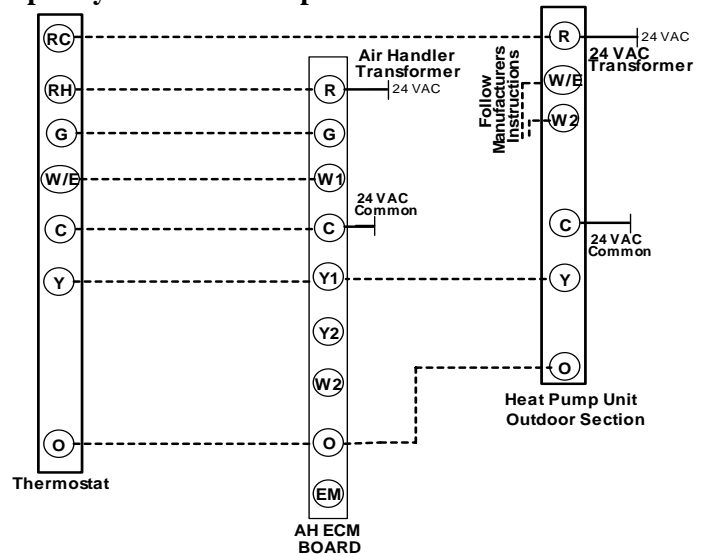

Figure 23: Typical Single Stage Heat with Single Stage Package Heat Pump Unit

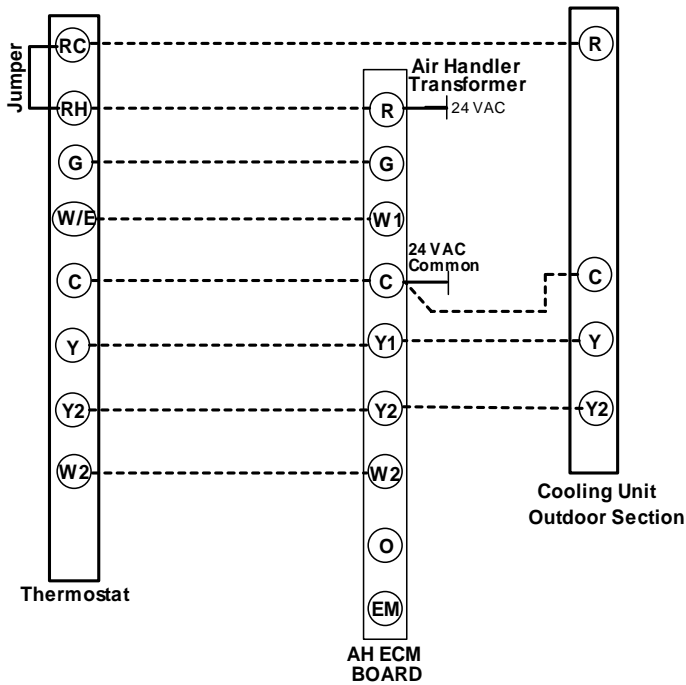

Figure 24: Typical Two Stage Heat with Two Stage Split System Cooling

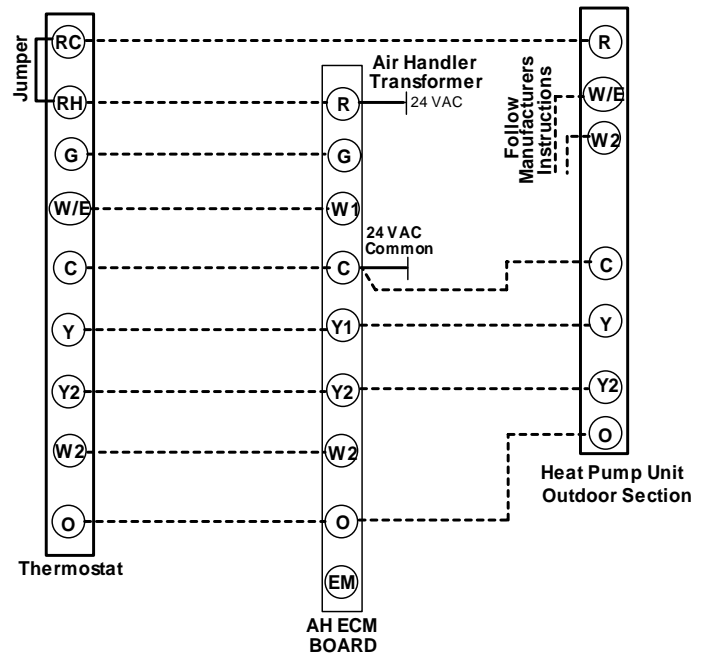

Figure 26: Typical Two Stage Heating with Two Stage Split System Heat Pump

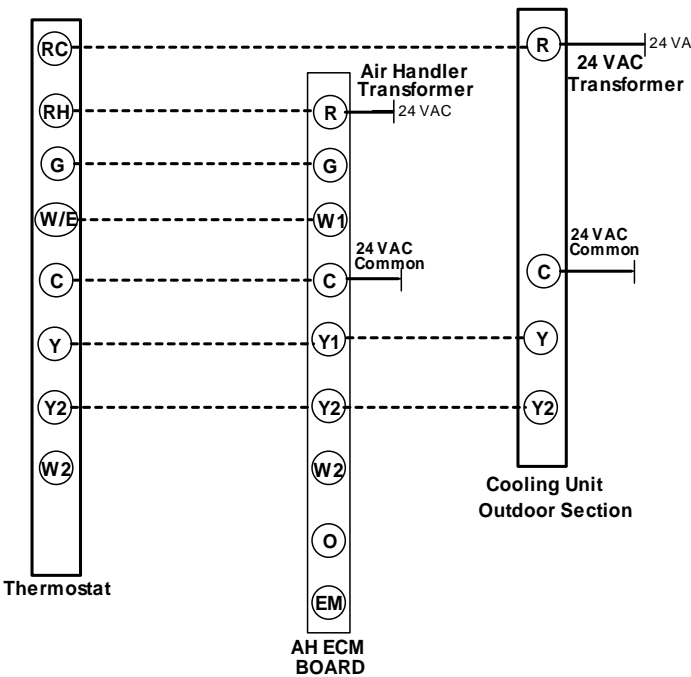

Figure 25: Typical Single Stage Heat with Two Stage Package Cooling Unit

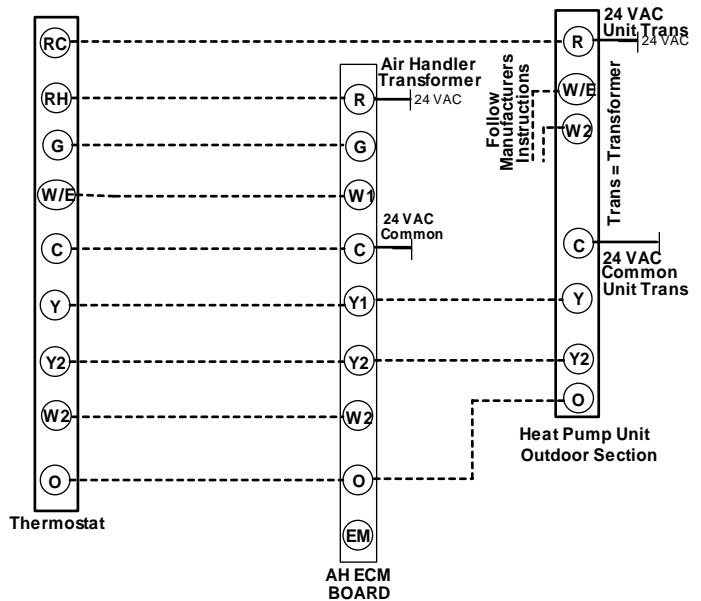

Figure 27: Typical Two Stage Heat with Two Stage Package Heat Pump

Wire Color	Description	Letter Code	Furnace Pig Tail Wire Connection	Thermostat Connection	Condenser Connections
RED	24 VAC	R	Red	R	N/A
WHITE	Heat (1st Stage Heat)	W	White	W or W1	N/A
GREEN	Indoor Fan	G	Green	G	N/A
YELLOW	Cooling - Stage 1	Y	Yellow	Y or Y1	Y or Y1
GREY	24 VAC Common	GRY	Grey	C	C

Note: Single stage thermostat on two stage models must connect white (W1) pigtail wire and black (W2) pigtail wire together in low voltage box with W wire from the thermostat.

Table 14: Recommended Heating / Cooling Thermostat Wire Color Codes and Connections.

Wire Color	Description	Letter Code	Furnace Pig Tail Wire Connection	Thermostat Connection	Condenser Connections
RED	24 VAC	R	Red	R	N/A
WHITE	Heat (1st Stage Heat)	W	White	E	N/A
GREEN	Indoor Fan	G	Green	G	N/A
YELLOW	Cooling - Stage 1	Y	Yellow	Y or Y1	Y or Y1
GREY	24 VAC Common	GRY	Grey	C	C
BROWN	Heat (Optional 2nd Stage Heat)	BRN	Brown	W2	N/A
ORANGE	Heat Pump Reversing Valve Solenoid	O	N/A	O	O
BLUE	Cooling - (Optional 2nd Stage Cooling)	BLU	N/A	Y2	Y2

Table 15: Recommended Heating / Cooling / Heat Pump Thermostat Wire Color Codes and Connections.

Typical Heating/Cooling Thermostat Wiring Connections

1. Remove blower / control box access door.
2. Remove the control box cover.
3. Install a grommet or strain relief in the 9/16" hole on the top and the right side of the air handler casing to protect the thermostat wire cable.
4. Strip 1/2" of the insulation on the end of each wire.
5. Insert the wire cable from the thermostat thru the 9/16" hole into the control box and place the thermostat wire cable next to the low voltage pigtailed. Secure the thermostat wire cable with a strain relief to prevent wire connections from being pulled apart.
6. Connect the Red (24 VAC) supply thermostat wire to the Red low voltage pigtail wire and secure with a wire nut.
7. Connect the White (First stage heating) thermostat wire to the White low voltage pigtail wire and secure with a wire nut.
8. Connect the Green (Indoor fan) thermostat wire to the Green low voltage pigtail wire and secure with a wire nut.
9. Connect the Yellow (Air conditioning) wire from the thermostat with the Yellow low voltage pigtail wire on the air handler and with the Red wire from the compressor contactor on the condenser unit. Fasten the three wires together securely with a wire nut.
10. Connect the Grey (24 VAC Common) wire from the thermostat with the Grey low voltage pigtail wire on the air handler and with the Grey (Common) wire from the compressor contactor on the outdoor unit. Fasten the three wires together securely with a wire nut.
11. Connect the Brown (2nd stage heating) thermostat wire to the brown low voltage pigtail wire and secure with a wire nut.
12. If a two stage outdoor unit is used then connect the "W2" wire from the outdoor unit to the brown wires discussed in step 11 and secure with a wire nut.

NOTE: If single stage thermostat is used on a two stage air handler connect the brown and the white air handler pigtail wires and the white thermostat wire together; then, secure all three wires with a wire nut.

Typical Heat Pump - Heating/Cooling Thermostat Wiring Connections

1. Remove the blower / control box access panel.
2. Remove the control box cover.
3. Install a grommet or a strain relief in the 9/16" diameter hole on the top and the right side of the air handler casing to protect the thermostat wire cable.
4. Strip 1/2" of the insulation on the end of each wire.

5. Insert the wire cable from the thermostat thru the 9/16" hole into the control box and place the thermostat wire cable next to the low voltage pigtailed. Secure the thermostat wire cable with a strain relief to prevent wire connections from being pulled apart.
6. Connect the Red (24 VAC) supply wire from the thermostat to the Red low voltage pigtail wire on the air handler and with the Red wire from the "R" terminal on the outdoor unit. Fasten the three wires together securely with a wire nut.
7. Connect the White (first stage heating) wire from the thermostat to the White low voltage pigtail wire on the air handler and the White wire from the "E" terminal on the outdoor unit. Fasten the three wires together securely with a wire nut.
8. Connect the Green (indoor fan) wire from the thermostat to the Green low voltage pigtail wire on the air handler and securely fasten the two wires together with a wire nut.
9. Connect the Red wire from the "Y" terminal on the outdoor unit. Fasten the three wires together securely with a wire nut.
10. Connect the Grey (24 VAC Common) wire from the thermostat with the Grey low voltage pigtail wire on the air handler and with the Grey (Common) wire from the "C" terminal on the outdoor unit. Fasten the three wires together securely with a wire nut.
11. Connect the Orange (Reversing Valve Solenoid) wire from the thermostat with the Orange wire from the "O" terminal on the condenser unit. Fasten the two wires together securely with a wire nut.
12. Connect the Brown (2nd stage heating) thermostat wire to the brown low voltage pigtail wire and secure with a wire nut.
13. If a two stage outdoor unit is used then connect the "W2" wire from the outdoor unit to the brown wires discussed in step 12 and secure with a wire nut.

NOTE: If single stage thermostat is used on a two stage air handler connect the brown and the white air handler pigtail wires and the white thermostat wire together; then, secure all three wires with a wire nut.

SECTION X: MOTOR, BLOWER AND FURNACE STARTUP SECTION

WARNING

To avoid personal injury or property damage, make certain that the motor leads cannot come into contact with non-insulated metal components of the unit.

Selecting the X-13 Blower Speed

This furnace uses the new X-13 high efficiency motor. This motor operates on 240 VAC. The motor speed tap are 24 VAC, 0.03 amps, 60 Hz, 1 PH. The speed taps can be changed by removing the black wire from the isolation relay terminal #4 or the red wire from the isolation relay terminal #6 and connecting either the blue, orange, or purple wire to the terminal. Table 16 shows the X-13 motor lead connection labeling and the connection definitions.

Terminal	Connection
C	Speed Tap Common - 24 VAC Common
L	Supply Voltage - 240 Vac Line 1
G	Ground Connection
N/L2	Supply Voltage - 240 Vac Line 2
1	Low Speed Tap - 24 VAC Input
2	Medium-Low Speed Tap - 24 VAC Input
3	Medium Speed Tap - 24 VAC Input
4	Medium-High Speed Tap - 24 VAC Input
5	High Speed Tap - 24 VAC Input

Table 16: X-13 Motor Terminal Connections

Total 24 VAC circuit amps are 0.14 amps.

Change Motor Speeds - X-13 Motor

1. Turn off **all** electrical supply circuits to the air handler at the main service (House Circuit Breaker) panel.
2. Remove the blower door and switch furnace circuit breaker(s) to "OFF".
3. Disconnect the wire from the isolation relay terminal and reconnect the desired wire to the terminal. Here is the X-13 motor speed tap wire color code. Black wire is High Speed, Orange wire is Medium High Speed, Blue wire is Medium Speed, Purple wire is Medium Low Speed, and Red wire is Low Speed.
4. Turn the circuit breakers on and reinstall air handler blower door.
5. Turn on **all** electrical supply circuits to the air handler at the main service (House Circuit Breaker) panel.
6. Set the thermostat to the desired temperature.

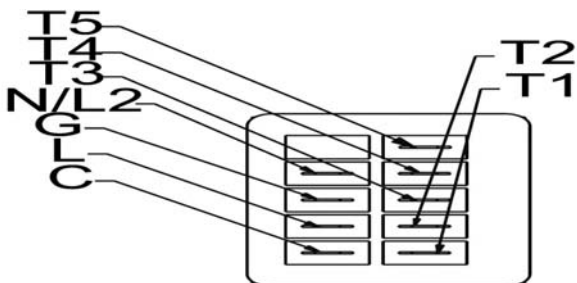

Figure 28: X-13 Motor Terminals

Replacing the X-13, ECM, 3/4 HP PSC and 1 HP PSC Blower Motor

1. Turn off all electrical supply circuits to the air handler at the main service panel.
2. Remove air handler blower door and switch the air handler circuit breaker(s) to "OFF"
3. Disconnect the power cable and the speed tap cable that connect to the blower motor.
4. Remove the two screws on the right side and the three screws on the left side of the blower mounting plate.
5. Slide the blower out of the blower compartment and set on the floor.
6. Loosen the wheel set screw by placing on wrench on the screw head and turning counter clockwise. Loosen the wheel set screw until the shaft can spin freely 360° while inside the wheel hub. The wheel set screw is located on the wheel hub on the opposite side of the motor.
7. Remove the blower motor from the blower housing by removing the screws on the sides of the housing that secure the blower to the housing
8. Remove the blower motor mount assembly by loosening the belly band bolt and nut, then, remove the belly bands and mount legs.
9. Insert the new blower motor into the blower mounting bracket making sure the mounting legs are properly placed into the belly band and the legs are straight. Tighten the belly band screw and nut until belly bands is securely fastened to the motor.
10. Place the motor into the housing so the mount leg holes line up with the rivet nuts in the housing. Place the screw into the mount leg holes and tighten until the mount legs are securely fastened to the housing.
11. Center the blower wheel in the housing, turn the motor shaft so the wheel set screw is located on the center of the flat spot of the shaft and tighten the set screw.
12. Connect the same two cables that were removed in step 3.
13. Slide the blower assembly into the blower deck and insert the screws on the right and left sides of the mounting bracket.
14. Switch the circuit breakers to ON and replace air handler blower door.
15. Turn on all electrical supply circuits to the furnace at the main service (House Circuit Breaker) panel.
16. Set the thermostat to the desired temperature.

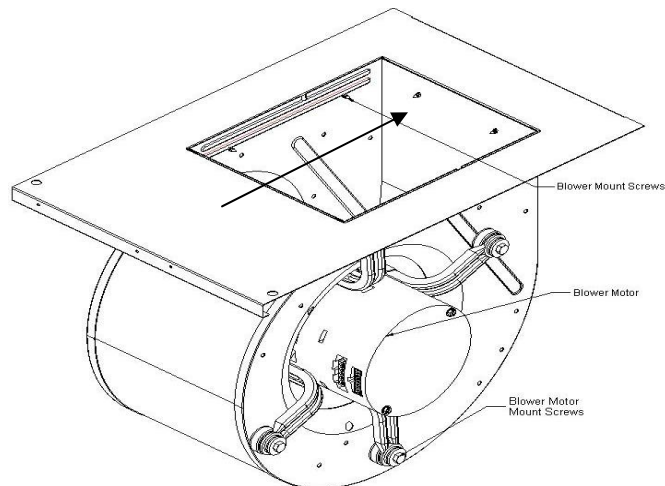

Figure 29: Blower Assembly and Blower Deck

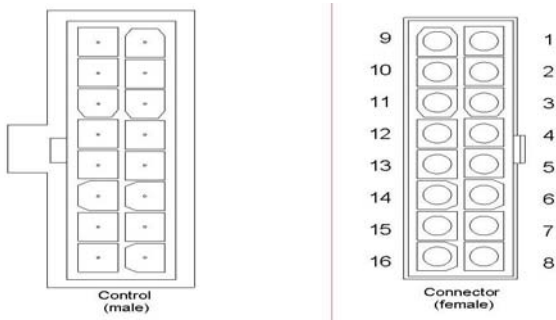

Figure 30: ECM Motor Control Pin out

- | | |
|----|------------------------------------|
| 1 | Common C1 |
| 2 | W/W1 |
| 3 | Common C2 |
| 4 | Delay Tap Select |
| 5 | Cool Tap Select |
| 6 | Y1 |
| 7 | Adjust Tap Select |
| 8 | Output – |
| 9 | Reversing Valve (Heat Pump Only) |
| 10 | Humidistat (BK) |
| 11 | Heat Tap Select |
| 12 | 24 VAC (R) |
| 13 | 2 nd Stage Heat (EM/W2) |
| 14 | 2 nd Stage Cool (Y/Y2) |
| 15 | Fan (G) |
| 16 | Output + |

Table 17: ECM Motor Control Connector Terminal Descriptions

Change Motor Speeds - ECM Motor

- Turn off **all** electrical supply circuits to the air handler at the main service (House Circuit Breaker) panel.
- Remove the blower door and switch furnace circuit breaker(s) to “OFF”.
- Motor speed can be changed for both heating and cooling modes. Heating blower motor speed change is done by moving the jumper on the “**HEAT**” jumper pins to a different setting. Pin out is shown below:
A = High Speed, B = Medium High Speed, C = Medium Speed, and D = Low Speed.
The blower motor speed can also be changed for cooling by moving the jumper on the “**COOL**” jumper pins to a different setting. Pin out is shown below:
A = High Speed, B = Medium High Speed, C = Medium Speed, and D = Low Speed.
The **ADJUST** pin is used to increase or decrease the blower motor speed by 10% to 12% from the **HEAT** or **COOL** setting. Placing the jumper in normal will allow no increase or decrease in the motor speed. The + setting will increase the motor speed by 10% to 12% above the **HEAT** or **COOL** setting. The – setting will decrease the motor speed by 10% to 12% below the **HEAT** or **COOL** setting.

WARNING

The **test** setting on the ADJUST jumper pins must not be used except for trouble shooting to determine if the blower operates.

The **PROFILES** jumper pins are used for blower motor on and off delays. See Climate Profiles in the back of the **SERVICE AND MAINTENANCE MANUAL** of these instructions to determine the proper setting for the climate in your area.

- Turn the circuit breakers on and reinstall air handler blower door.
- Turn on **all** electrical supply circuits to the air handler at the main service (House Circuit Breaker) panel.
- Set the thermostat to the desired temperature.

Change Motor Speeds - PSC Motor

- Turn off **all** electrical supply circuits to the air handler at the main service (House Circuit Breaker) panel.
- Remove the blower door and switch furnace circuit breaker(s) to “OFF”.
- Disconnect the wire from the isolation relay terminal and reconnect the desired wire to the terminal. Here is the PSC motor speed tap wire color code.
Black wire is High Speed, Blue wire is Medium Speed, and Red wire is Low Speed. Brown wires for capacitor.
- Turn the circuit breakers on and reinstall air handler blower door.
- Turn on **all** electrical supply circuits to the air handler at the main service (House Circuit Breaker) panel.
- Set the thermostat to the desired temperature.

Replacing the 1/3 HP PSC and 1/2 HP PSC Blower Motor

- Turn off all electrical supply circuits to the air handler at the main service panel.
- Remove air handler blower door and switch the air handler circuit breaker(s) to “OFF”.
- Disconnect the power cable and the speed tap cable that connect to the blower motor.
- Remove the two screws on the right side and the two screws on the left side of the blower mounting plate. Refer to Figure 27 for screw locations.
- Slide the blower out of the blower compartment and set on the floor.
- Loosen the wheel set screw by placing on wrench on the screw head and turning counter clockwise. Loosen the wheel set screw until the shaft can spin freely 360° while inside the wheel hub. The wheel set screw is located on the wheel hub on the opposite side of the motor.
- Remove the blower motor from the blower housing by removing the three (3) screws on the sides of the housing that secure the blower to the housing
- Place the motor into the housing so the mount leg holes line up with the rivet nuts in the housing. Place the three (3) screws into the mount leg holes and tighten until the mount legs are securely fastened to the housing.
- Center the blower wheel in the housing, turn the motor shaft so the wheel set screw is located on the center of the flat spot of the shaft and tighten the set screw.
- Connect the same two wires that were removed in step 3.
- Slide the blower assembly into the blower deck and insert the screws on the right and left sides of the mounting bracket.
- Switch the circuit breakers to ON and replace air handler blower door.
- Turn on all electrical supply circuits to the furnace at the main service (House Circuit Breaker) panel.

14 Set the thermostat to the desired temperature.

SECTION XI: FINAL SYSTEM CHECKOUT

1. Refer to appropriate wiring diagram and recheck all wiring connections. Ensure that all wiring connections are tight.
2. Check blower motor connectors to make sure they are not damaged or loose.
3. If the control box cover was removed; reinstall control box cover.
4. Switch circuit breaker(s) to "ON" position.
5. Switch the furnace circuit breakers in the main service (House Circuit Breaker) panel to the ON position.
6. Set the blower selector switch to the ON position and check all of the duct connections for air leaks. Seal any air leaks found.
7. Set the blower selector switch to the AUTO position.
8. Set the thermostat above the room temperature to check for proper operation of the electric heaters.
9. Set the thermostat to the desired temperature.

If the ECM motor dehumidify program is no longer desired by the home owner, simply move the jumper pin back to the OFF position to disable the motor program.

Control Board Flash Code

The ECM control board has a CFM flash code when the air handler is operation to indicate the current CFM.

- Typically flashes once per 100 CFM.
- To determine the selected CFM, count the number of flashes between pause flashes and multiply by 100.
- The sequence is followed by a 10 second OFF period signifying the end of the flash code, then the flash code starts over

Note: Since static will be low due to the removed panel, RPM will be lower to maintain the selected CFM

Example of the flash code:

The air handler is operating at 1400 CFM. The flash code will be 1 second flashes with pulse flashes, 0.1 seconds apart, 14 times, followed by a 10 second off, then the flash code starts over.

Thermostat Heat Anticipator

Some thermostats have a heat anticipator setting that must be set to the settings shown below in order to function correctly. If the heat anticipator setting is too low the furnace will short cycle. If the heat anticipator setting is too high the furnace will run long cycles thus causing the temperature to overrun the temperature setting. This will cause the home owner to feel hot by the time the blower completes its cycle; then cold, by the time the furnace cycles on again.

The heat anticipator should be set to the following settings.
For 5kW, 10kW, 15kW and 20 kW Models Set at 0.4

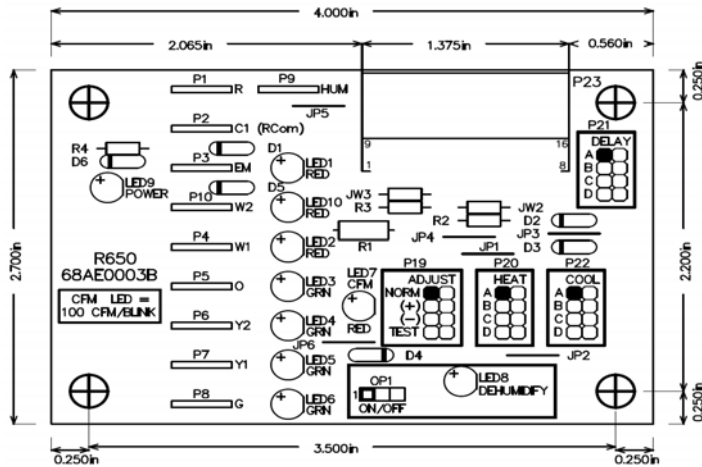

Figure 31: ECM Control Board Diagram

DEHUMIDIFY – The ECM board has a 0 ohm resistor or a jumper pin that provides 24 VAC to the HUM terminal keeping the motor from initiating the dehumidify program. Once the zero ohm resistor is cut, a 24 VAC signal must be present from the thermostat or humidistat when the humidity is below the set point. **The humidistat contacts must open when humidity is above the set point.**

The jumper pin configuration can be changed by moving the jumper from the OFF position to the ON position. Once the jumper pin has been changed to the ON position the humidistat will turn the dehumidify program in the motor on and off. The LED on the board will be lit when the motor is running the "dehumidify" programmed speed.

SECTION XII: WIRING DIAGRAMS

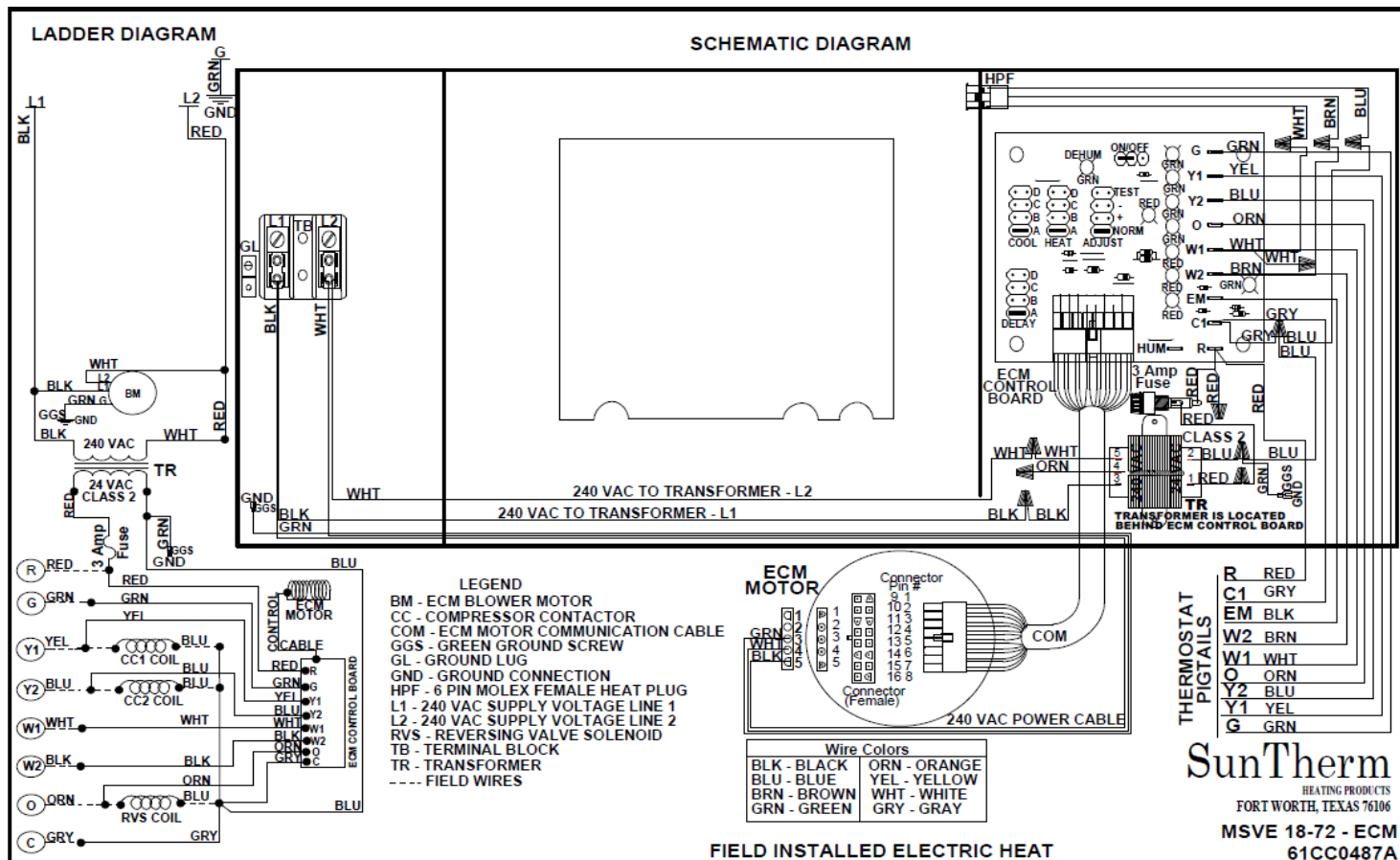

Figure 32: MSVE 18-72 - ECM 2.3 – No Electric Heater

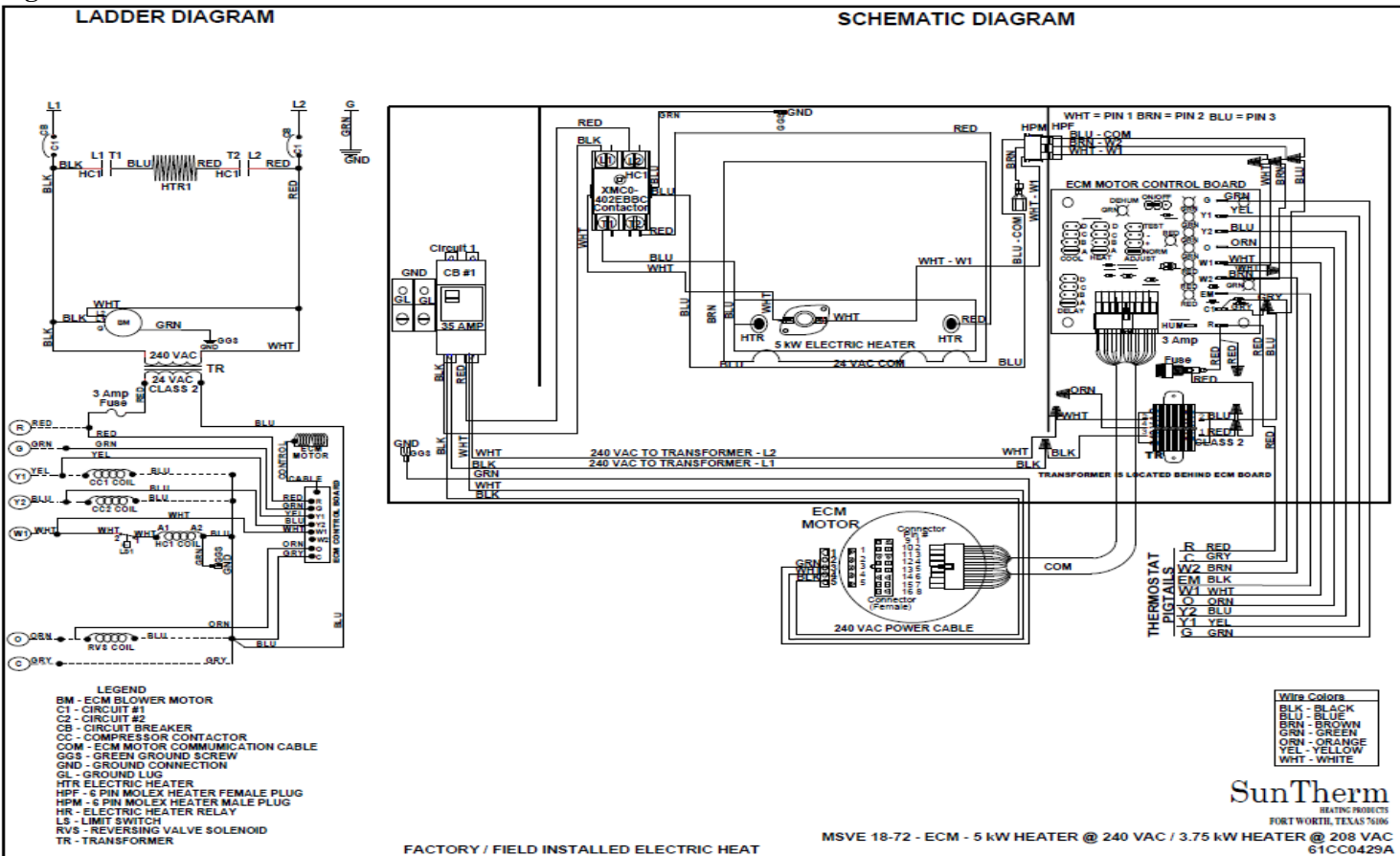

Figure 33: MSVE 18-72 – ECM 2.3 – 5 kW Electric Heater.

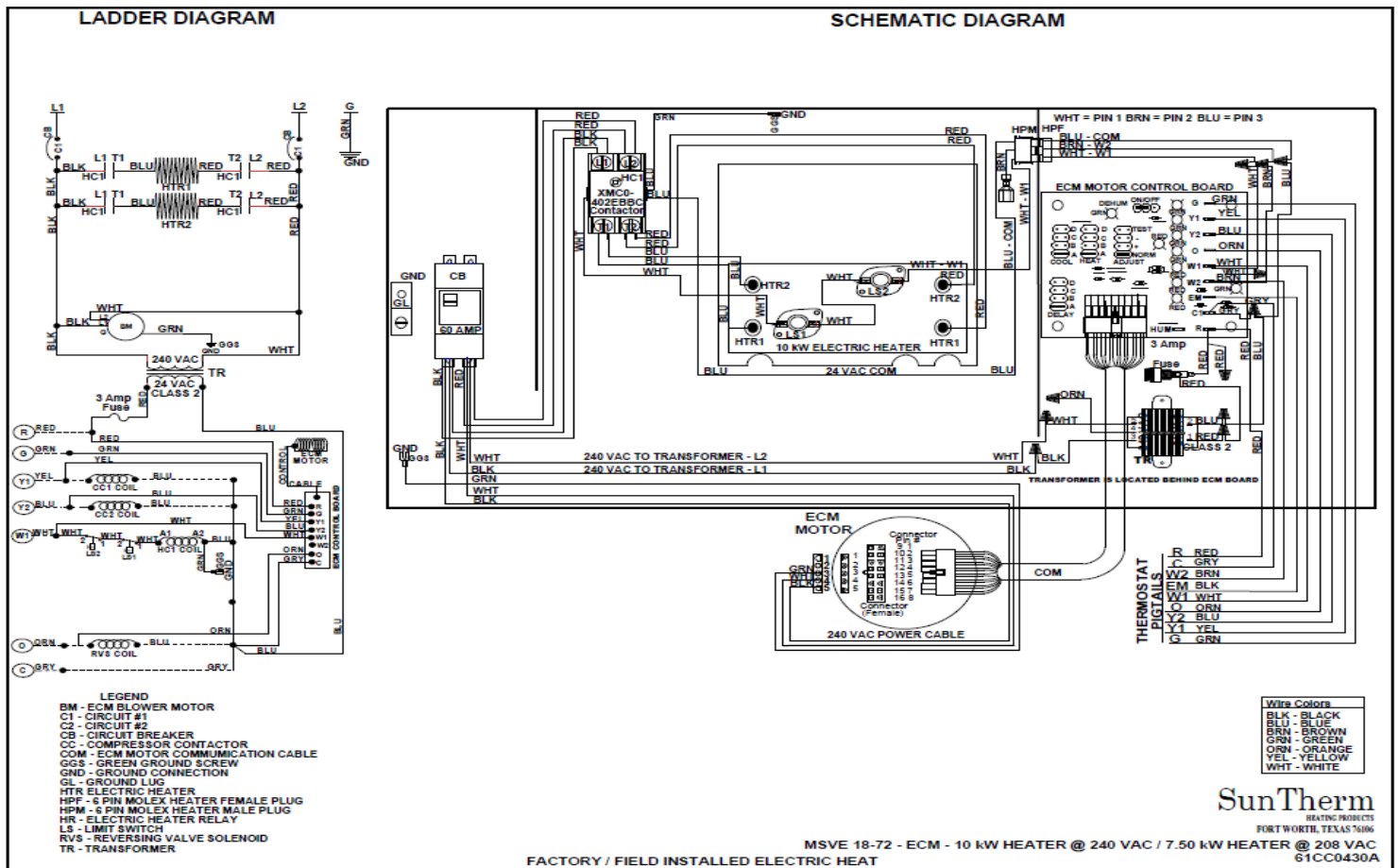

Figure 34: MSVE 25-72 – ECM 2.3 – 10 kW Electric Heater

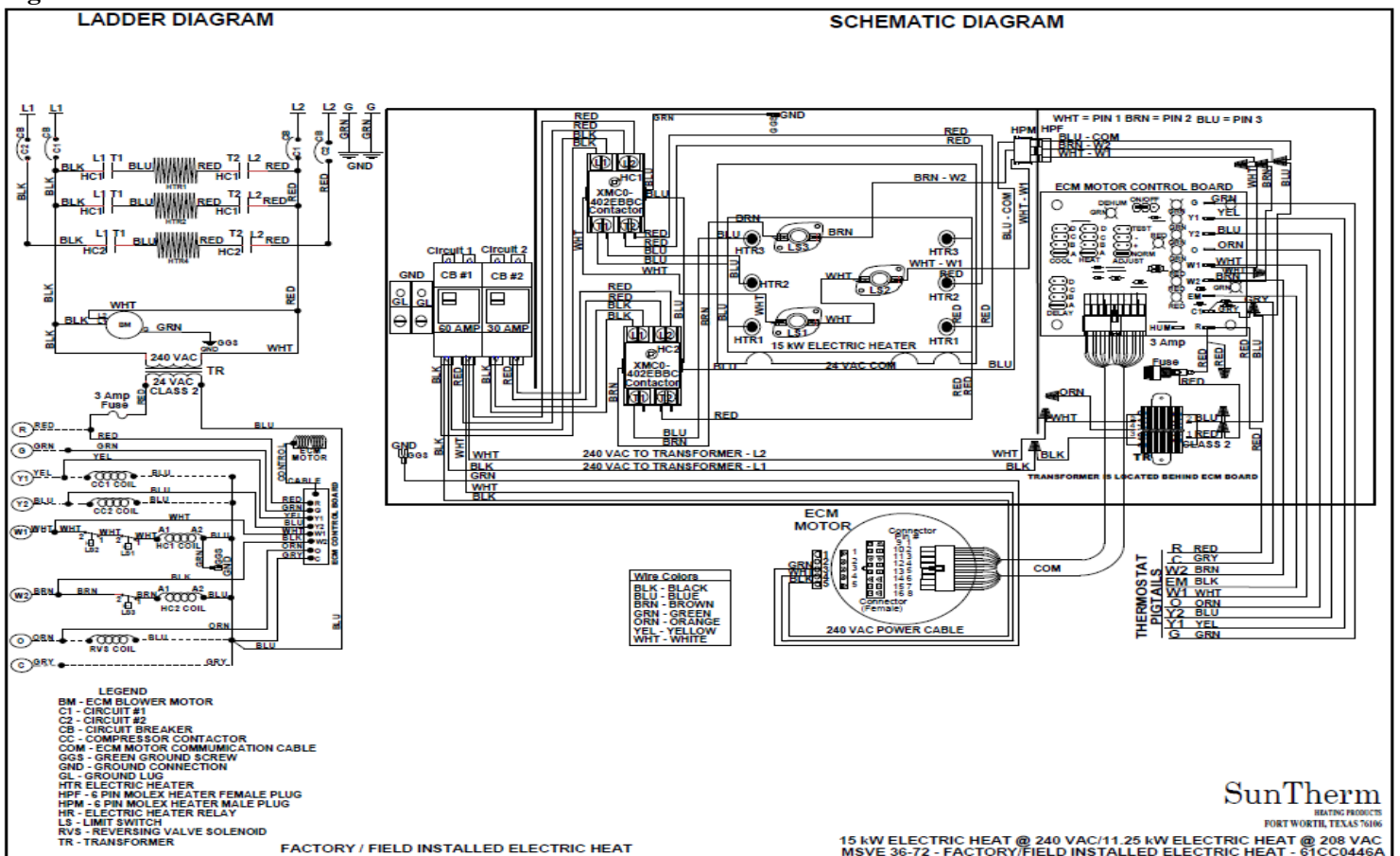

Figure 35 MSVE 37-72 – ECM 2.3 – 15 kW Electric Heater

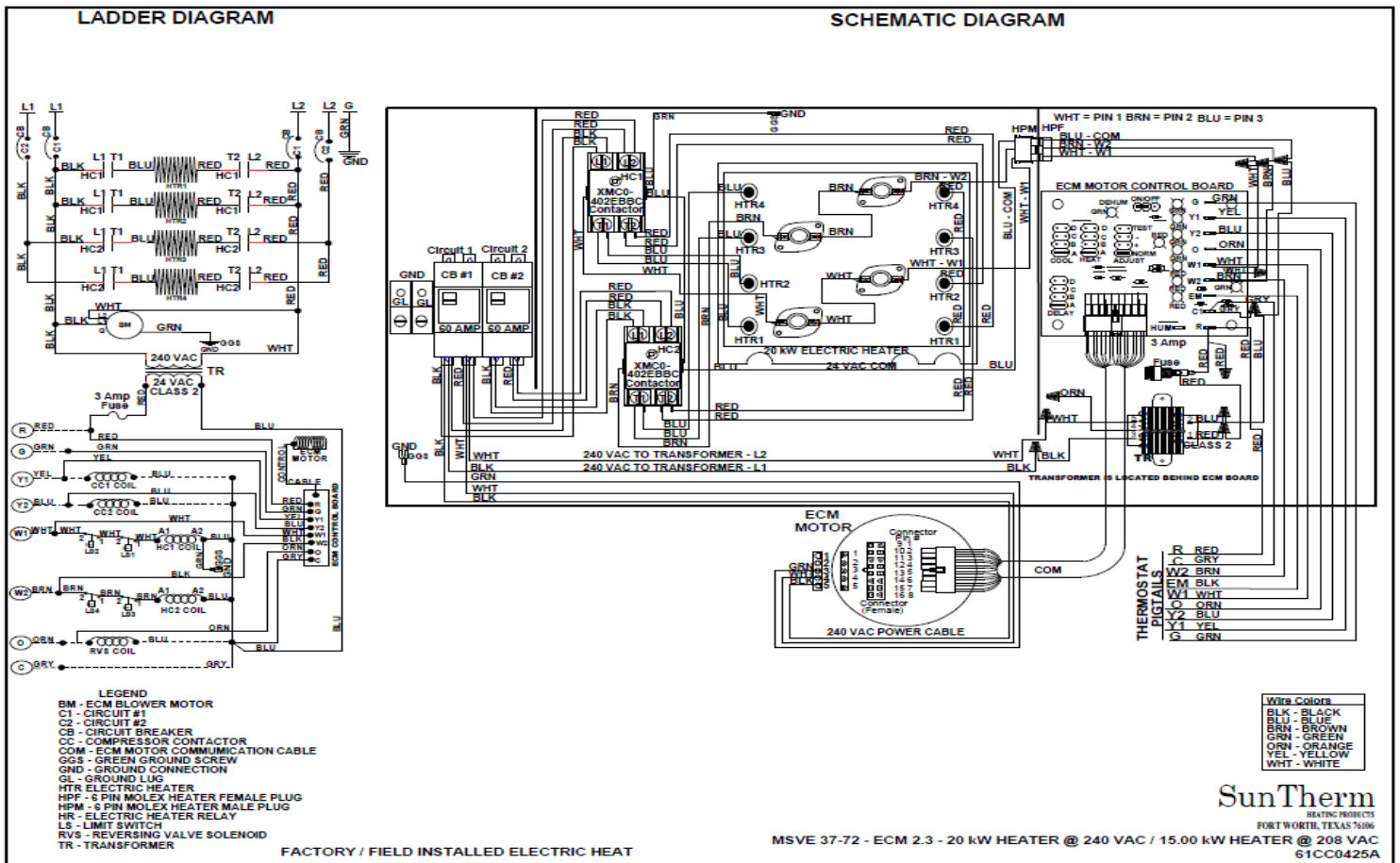

Figure 36 MSVE 42-72 – ECM 2.3 – 20 kW Electric Heater

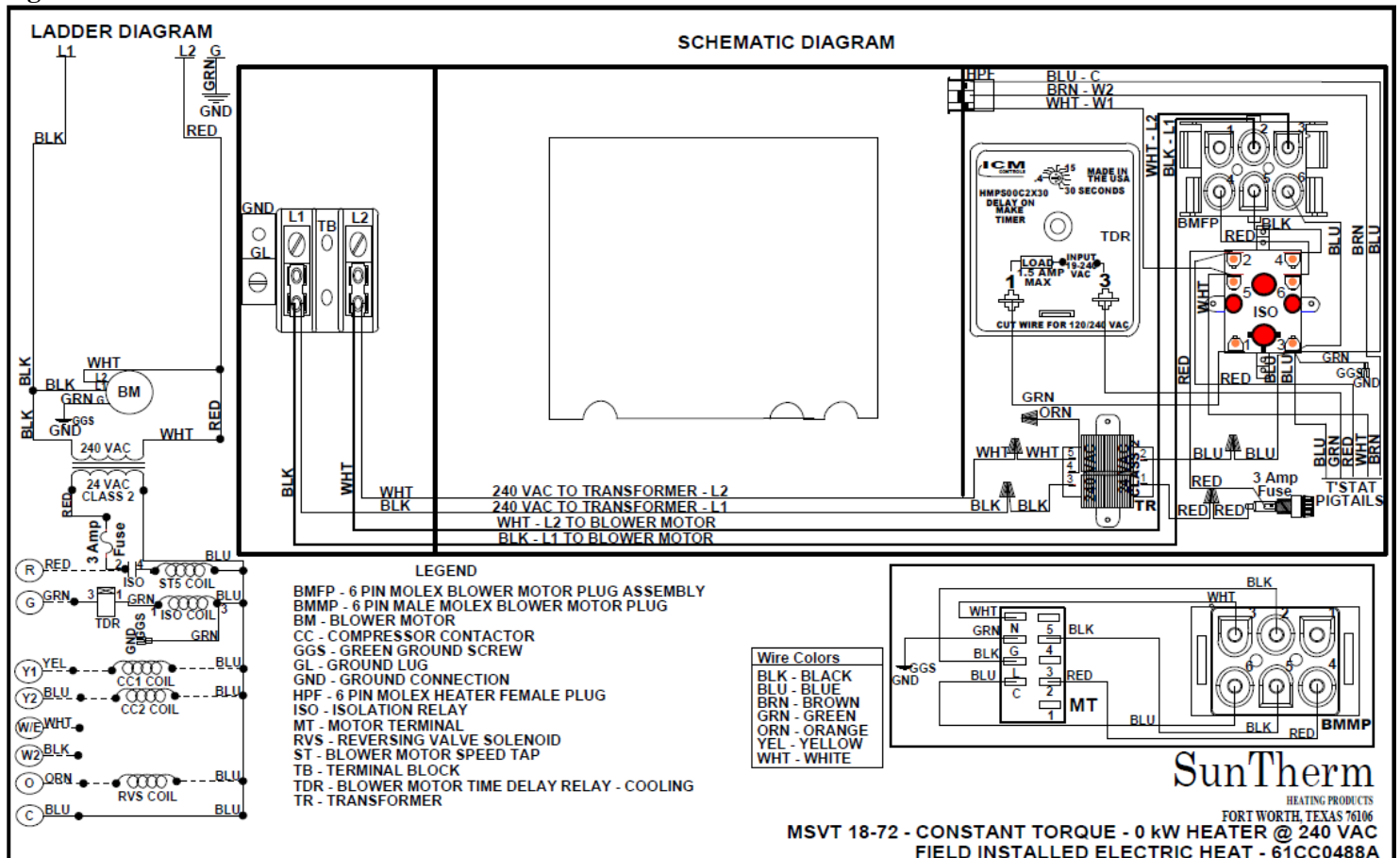

Figure 37 MSVT 18-72 – X-13 – No Electric Heater

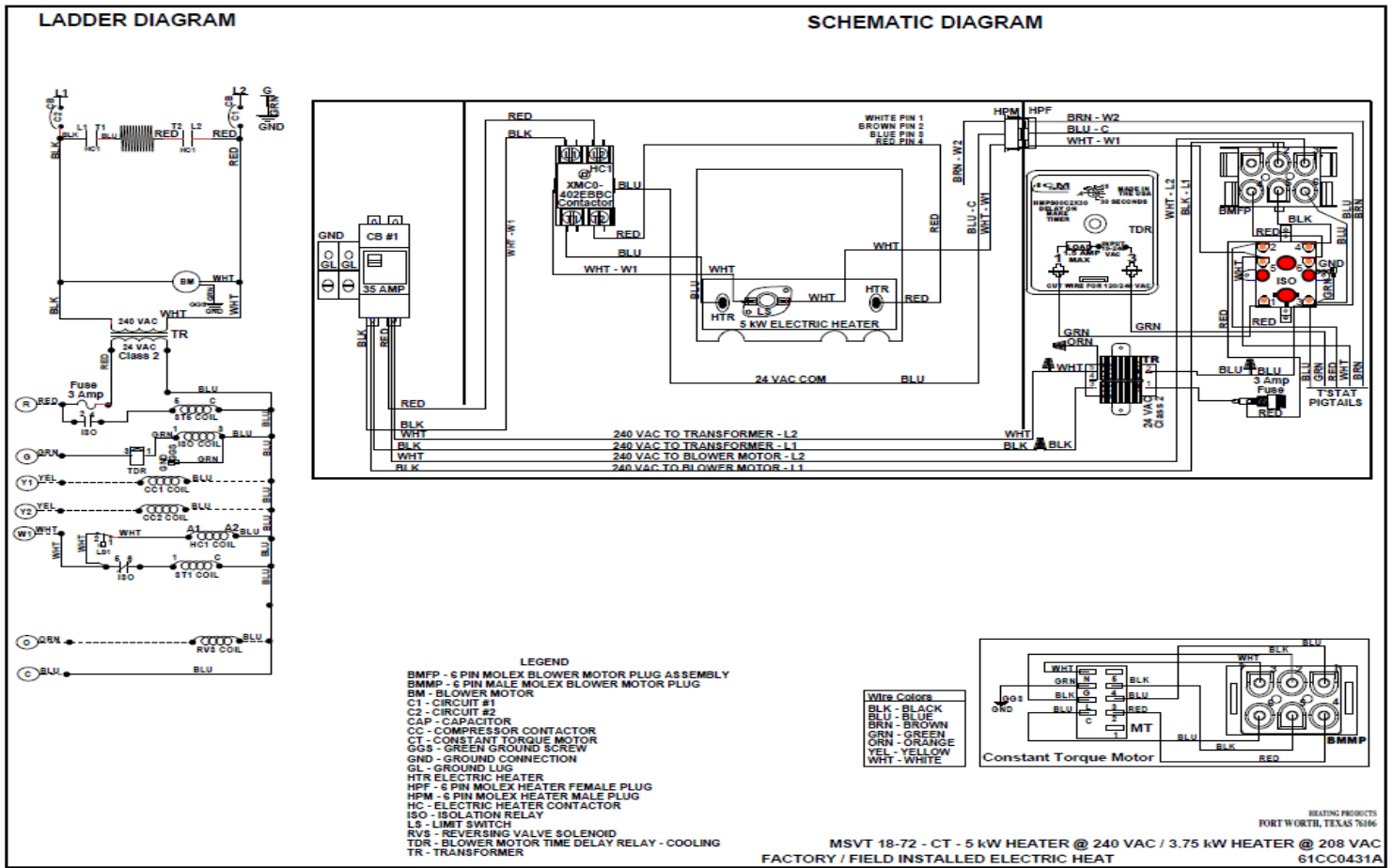

Figure 38 MSVT 18-72 - X-13 - 5kW Electric Heater

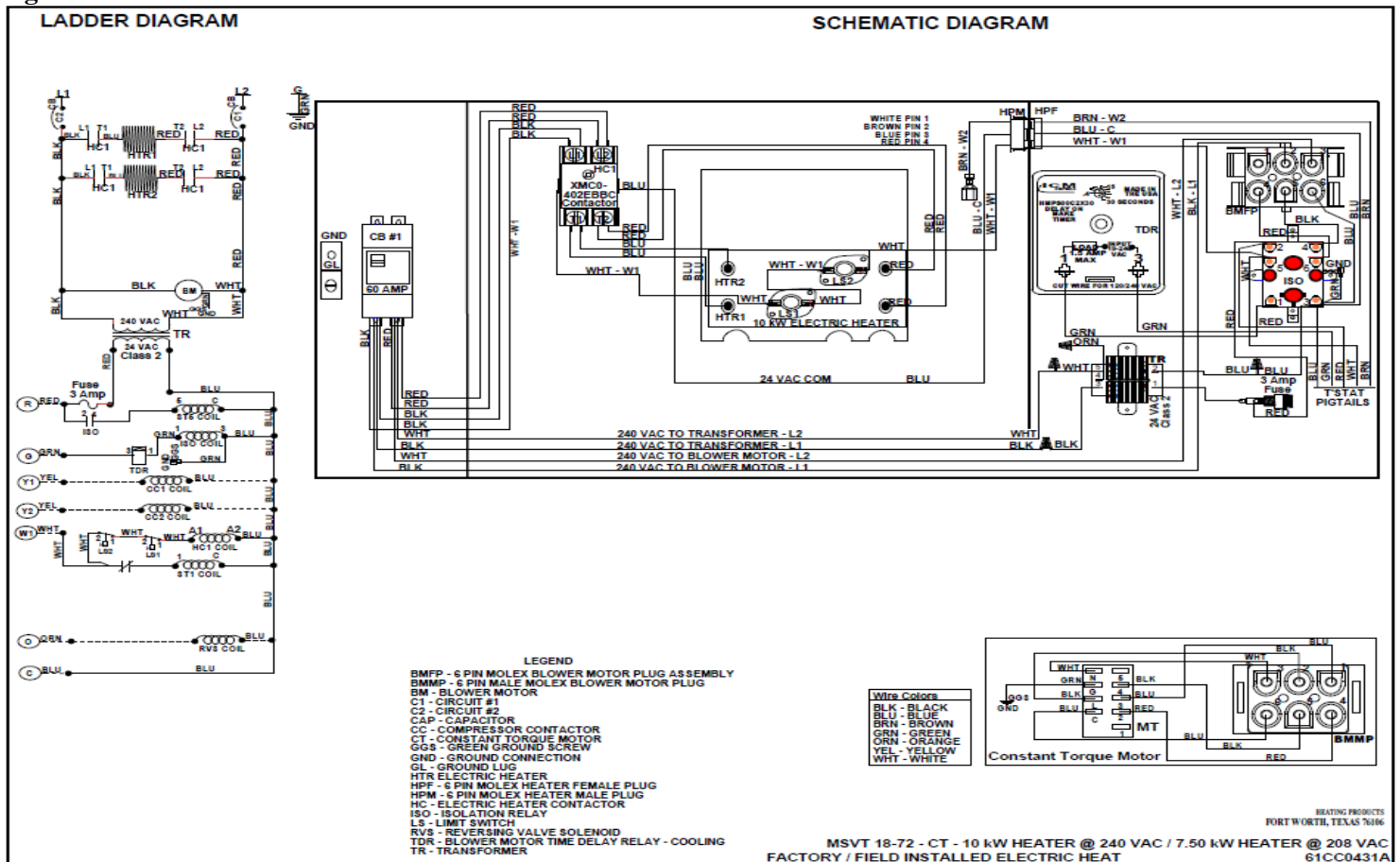

Figure 39 MSVT 18-72 - X-13 - 10kW Electric Heater

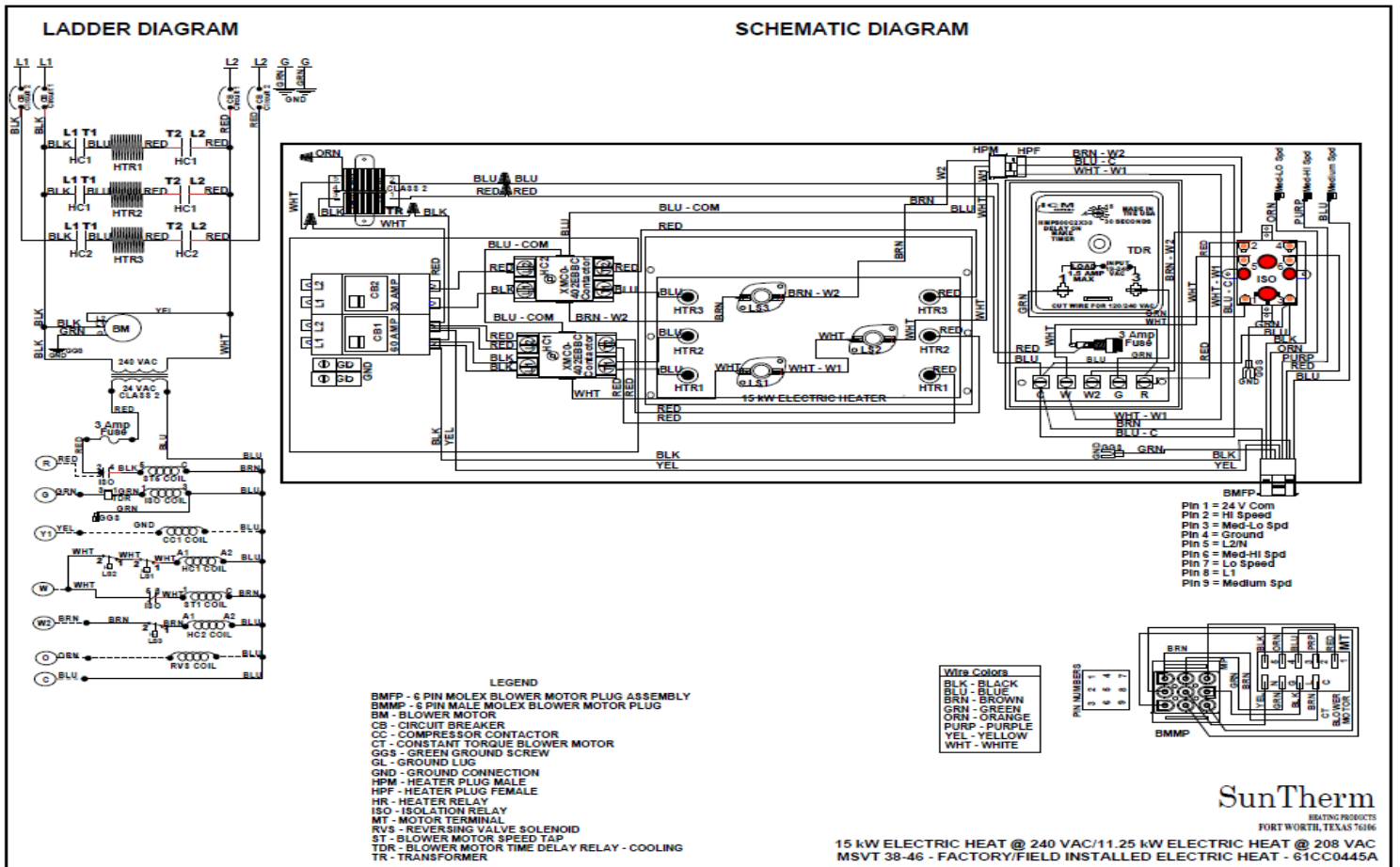

Figure 40 MSVT 36-72 - X-13 - 15kW Electric Heater

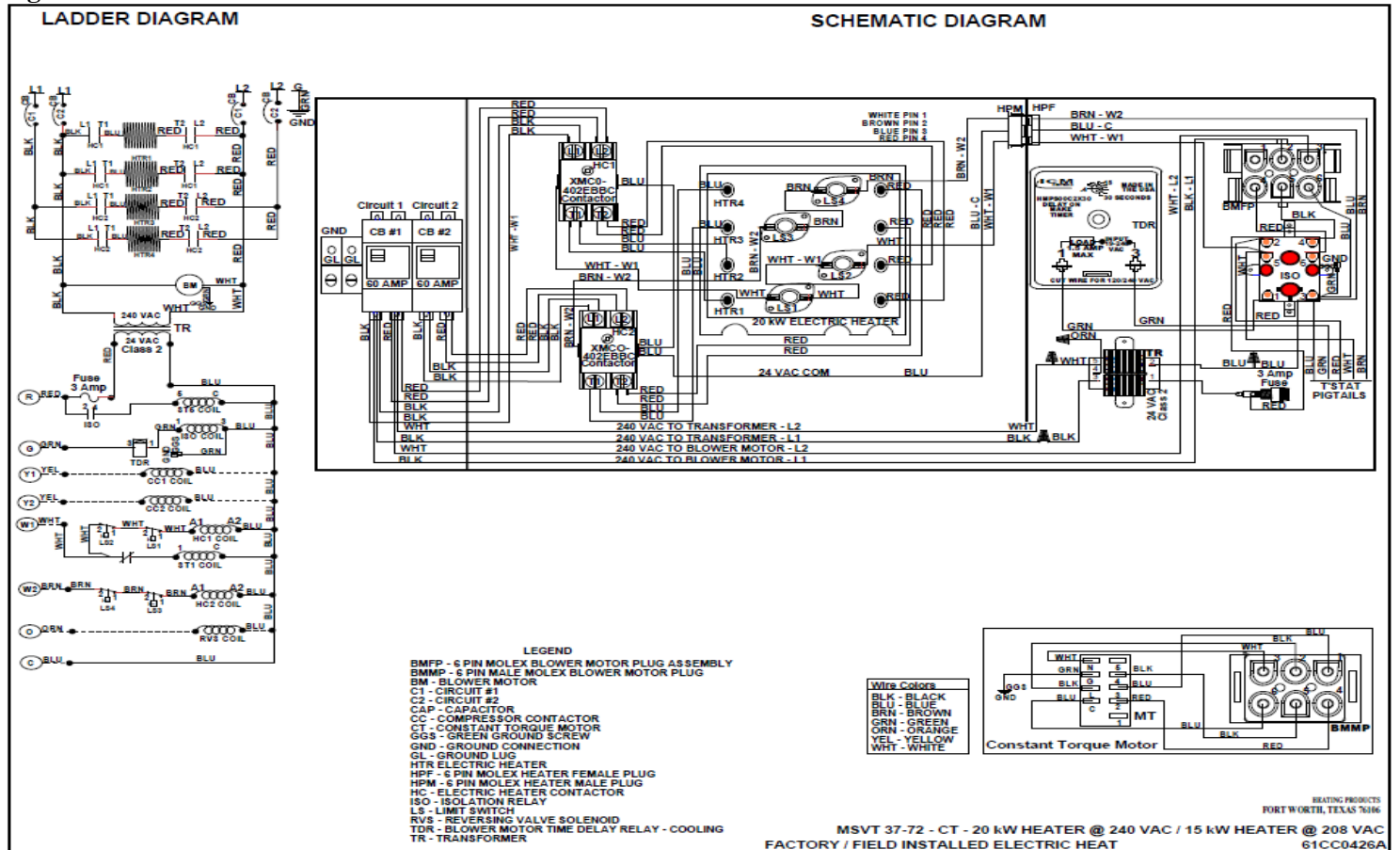

Figure 41 MSVT 37-72 - X-13 - 20kW Electric Heater

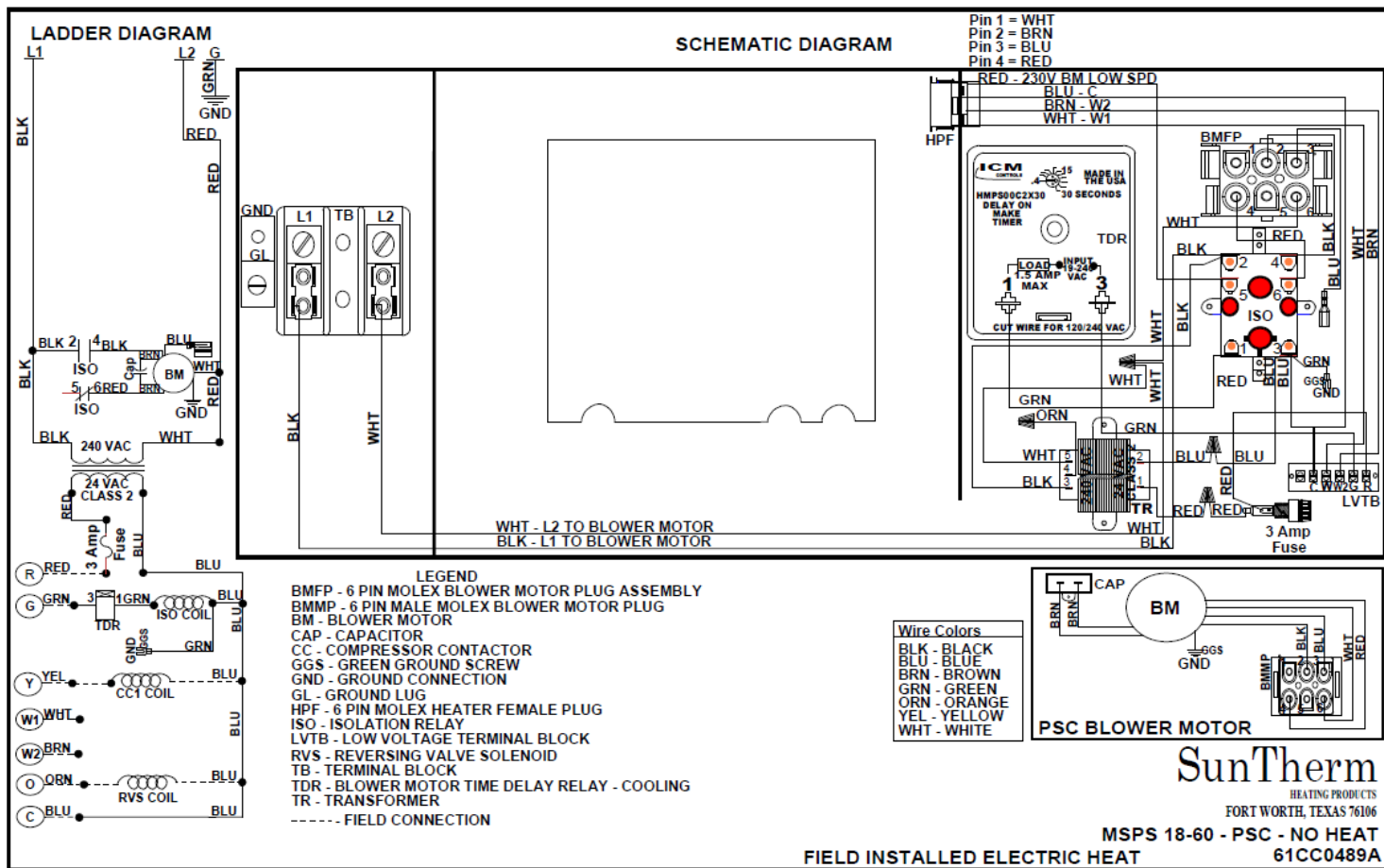

Figure 42 MSPS 18-60 – PSC – No Electric Heater

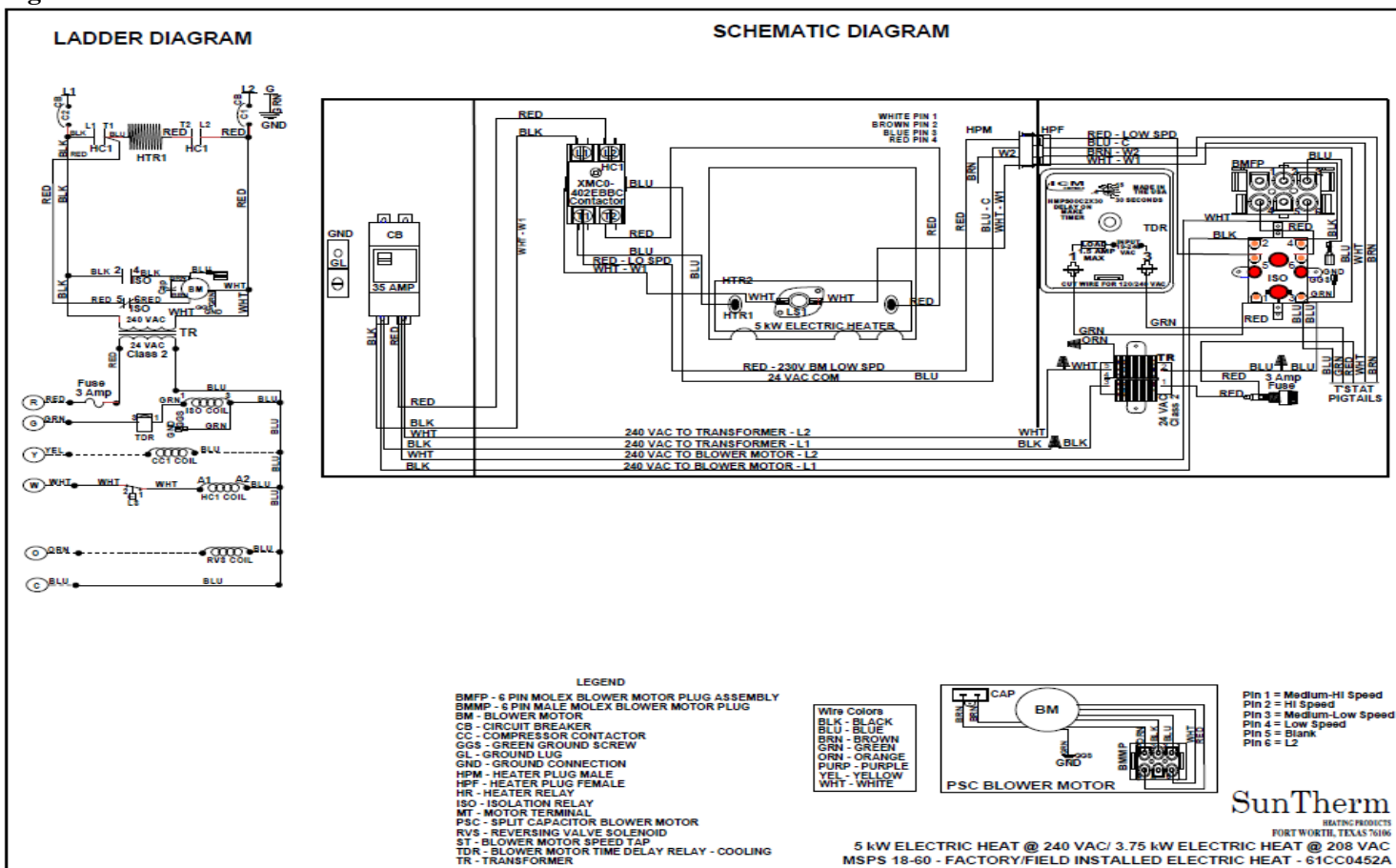

Figure 43 MSPS 18-60 – PSC – 5kW Electric Heater

MORTEX PRODUCTS INC. 501 TERMINAL RD FORT WORTH, TEXAS 76106

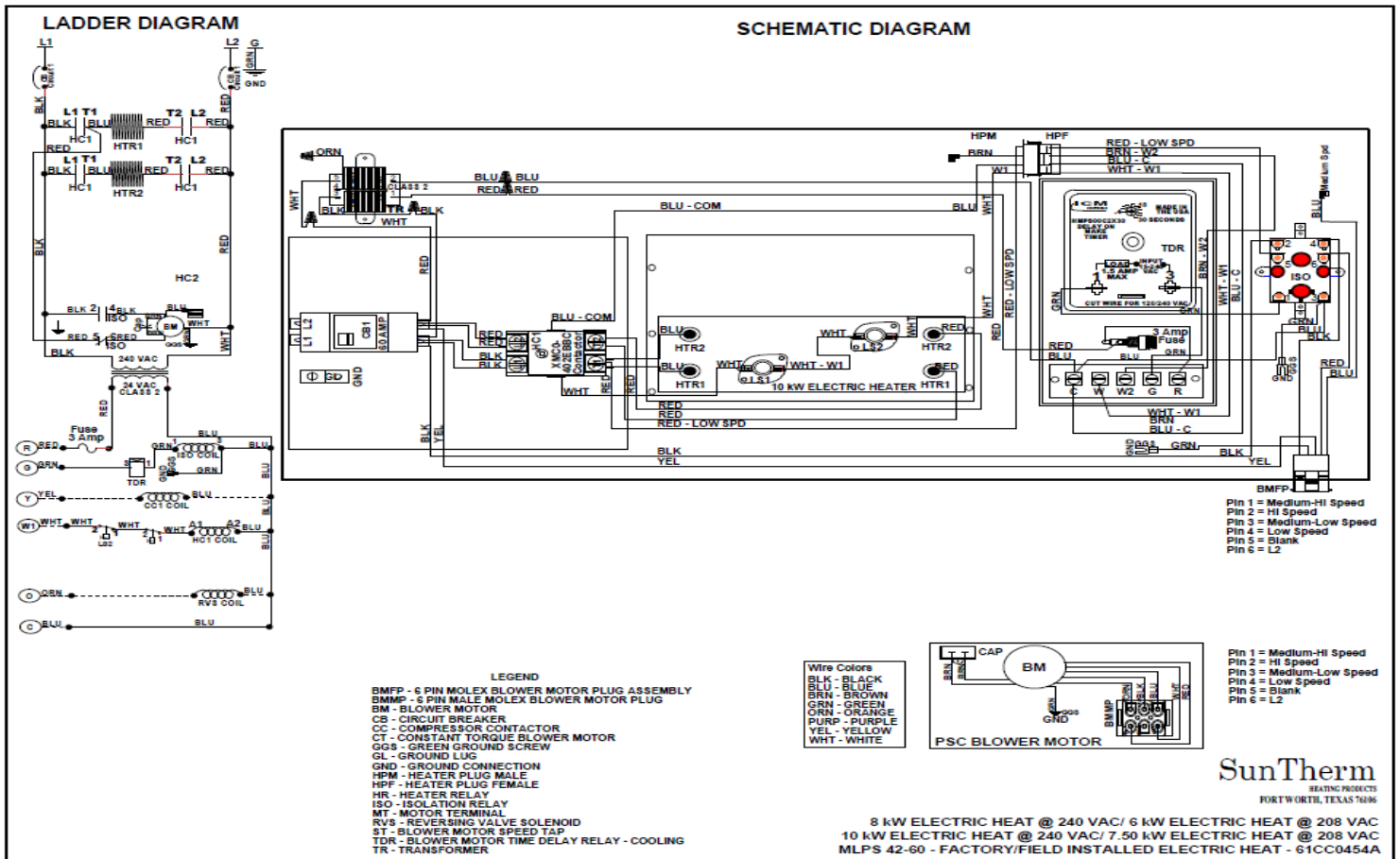

Figure 44 MSPS 18-60 – PSC – 10kW Electric Heater

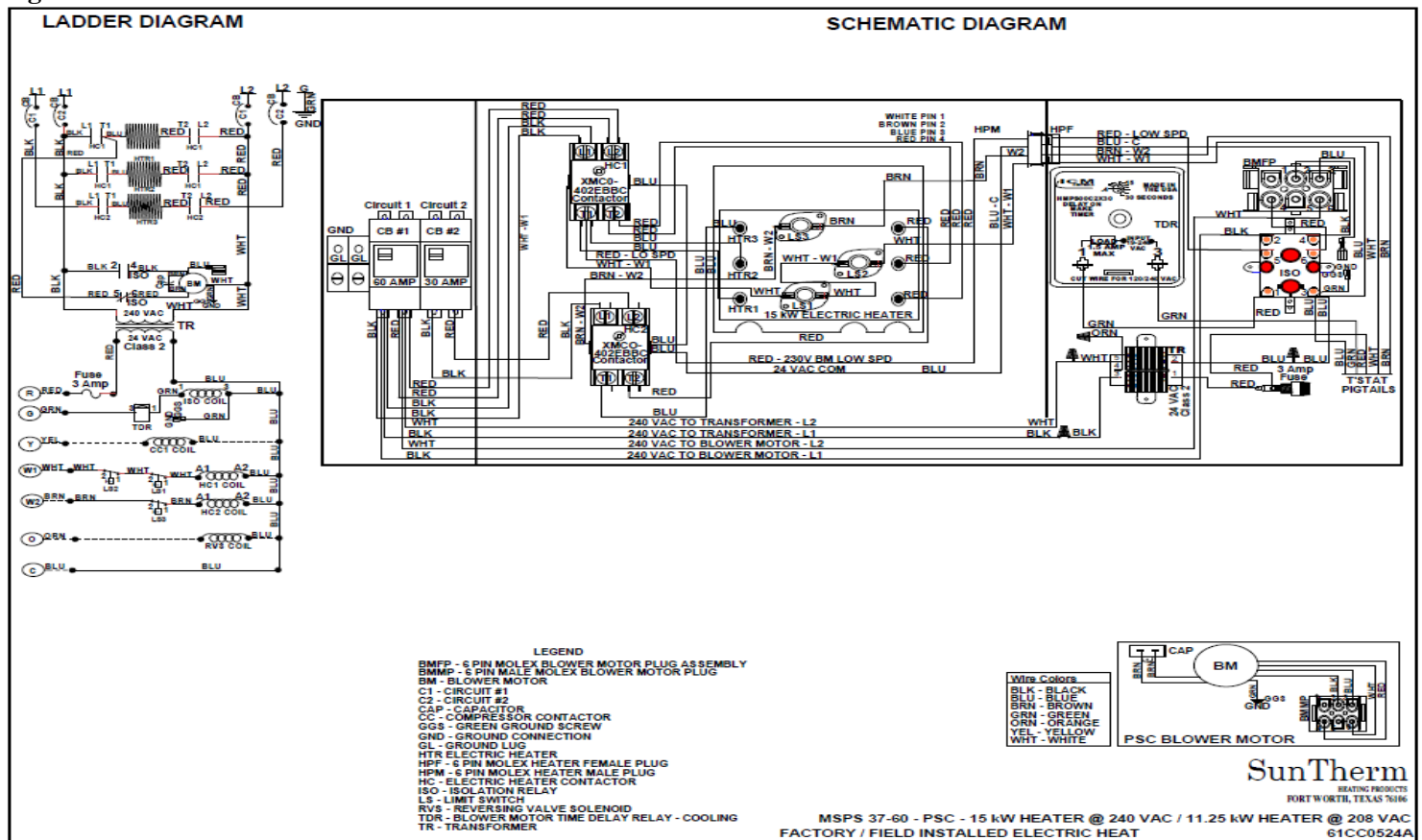

Figure 45 MSPS 30-60 – PSC – 15kW Electric Heater

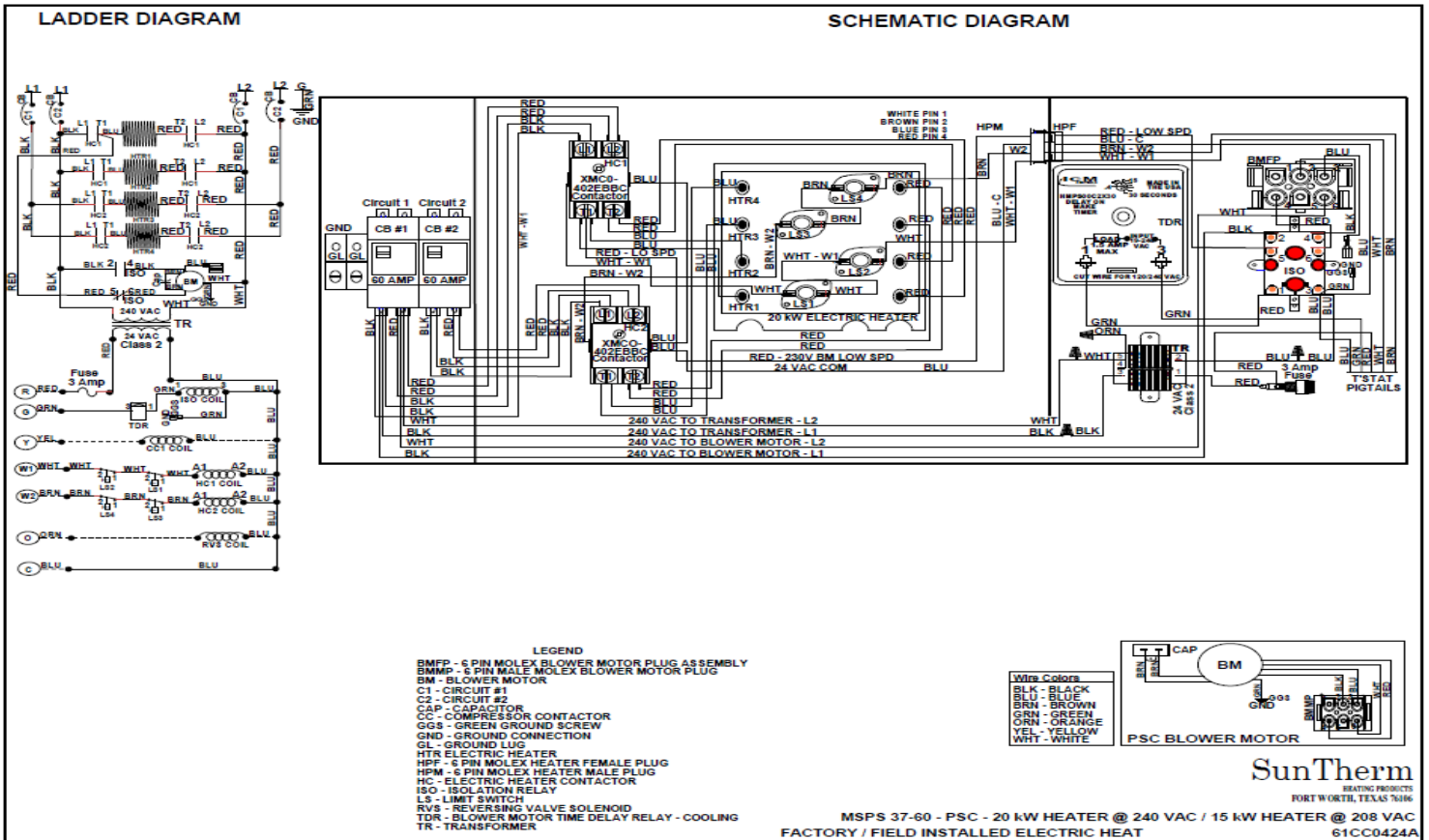

Figure 46 MSPS 37-60 – PSC – 20kW Electric Heater

Subject to change without notice
 Copyright by Mortex Products Inc. 2011.

61BA0013
 Supersedes: