



AIREX TITANOUTLET™

Seals HVAC Piping Wall Penetrations

Energy Efficient Product 

30%
Energy Savings
Mandate*



TGS Series

U.S. Patents #9,091,377 B2
#9,523,200 B2

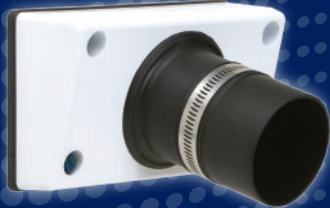

TSS Series

Siding or Compact Applications

TITAN OUTLET™

Seals Piping Wall Penetrations

- Superior Durable Quality with U/V Resistance & High Impact Strength Design
- Gasket Compression System Seals Wall Air Leakage & Weather Moisture Wall Damage
- Flexible Elastomeric Outlet Sleeve Design Prevents Air Infiltration & Rodent Intrusion
- Design Supports HVAC Systems with Wall Isolation & Anti-Vibration Features
- Flexible Sleeve Reduces Piping Vibration & Noise
- Seals to Protect Indoor Air Quality

Meets New Code Requirements:

- ✓ Building Codes
- ✓ Energy Codes
- ✓ Residential Codes
- ✓ Mechanical Codes
- ✓ Green Codes

2012 & 2015 International Energy Conservation Code (IECC)

Air Leakage (Mandatory): Residential Section 402.4

The *building thermal envelope* shall be constructed to limit air leakage in accordance with the requirements of Sections R402.4.1 through R402.4.4.

Air Barrier Construction: Commercial Section C402.5.1.1

Penetrations of the air barrier shall be caulked, gasketed or sealed in a manner compatible with the construction materials and locations...



Applications for:

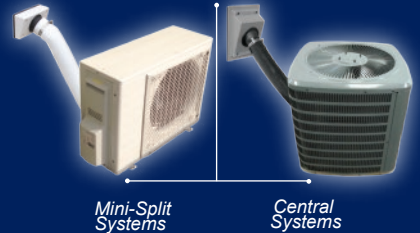

Mini-Split Systems

Central Systems

Weather Damage Protection



Residential

Commercial

Multi-Family Units

Codes & Standards Compliance

Air Leakage and Wall Penetration Compliance per:

- IBC - 2006, 2009, 2012 Chapter 13
- IRC - 2006, 2009, 2012 Chapter 11 Part IV Energy Efficiency - Section N1101 General - N1101.1 Scope - Air Leakage Section N1102.4 Section N1102.4.1 - Building Thermal Envelope - (1. All joints, seams, penetrations) Chapter 11 Refrigeration Section 1101.0 Scope - 1101.3 Protection
- IECC - 2006, 2009, & 2012 Air Leakage (Mandatory) - Residential Section 402.4.1 and 402.4.1.1 Building Thermal Envelope - Penetrations
- IECC - 2006, 2009, & 2012 Air Leakage (Mandatory) - Commercial Section C402.4.3 and C402.4.2 Building Thermal Envelope - Penetrations
- IMC - 2006, 2009, & 2012 Chapter 3 General Regulations Section 301.1 Scope - Sections 301.10, 301.11, 301.14, 301.15, 305.1, 305.2, 305.4
- UMC - 2006, 2009, & 2012 Chapter 11 Refrigeration - Section 1101.0 Scope - Section 1101.1 - General Requirements Section 1106.0 - Section 1106.2, Section 1111.0 Erection of Refrigerant Piping - Sections 1111.1, 1111.2, 1111.4
- California Building Energy Efficiency Standards (Title 24 Energy Code) 2016, Part 6 Section 110.7 - Mandatory Requirements to Limit Air Leakage

Approved Material & Performance Testing

- ASTM E283 - Standard Test Method for Air Leakage
- ASTM E331 - Standard Test Method for Water Penetration
- ASTM E 2178 - Air Permeance of Building Materials

Wall Mounted Outlet (Outdoor-Rated Rigid Plastic)

- ASTM D1525C-09 - Temperature Deformation Test
- ASTM D648-07 - Temperature Load Deformation Test
- UL 94 HB - Flammability Test
- UL 746C - Outdoor Suitability - f1 Rating

Wall Outlet Sleeve (Outdoor-Rated Elastomeric Plastic)

- ASTM D573-04 - Deterioration Test
- ASTM D746-07 - Brittleness Temperature Impact Test



*Based on HVAC Industry and Manufacturer's Independent Study on a Combined ROI & Sustainable Energy Savings Calculation. A contributing product to the U.S. Energy Department's 30% Energy Savings Solution Initiative.



Project _____
 Contractor _____
 Date _____
 Specification Reference _____
 Comments _____

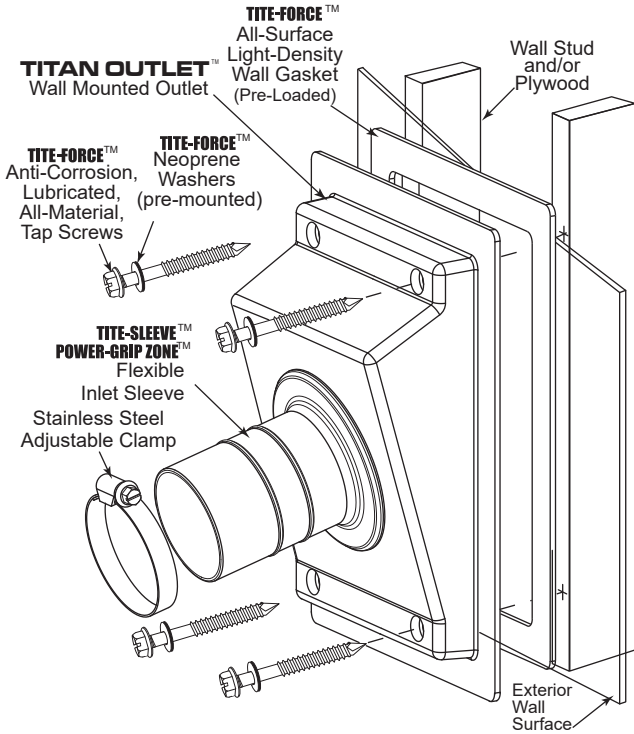

TITAN OUTLET MODEL NUMBERS

Airex Part Number	Model TGS: Stucco, Masonry Applications
TGS-550-W	(Fits: 1/2" wall thickness pipe insulation with 5/8", 3/4", 7/8" tube)
TGS-575-W	(Fits: 3/4" wall thickness pipe insulation with 5/8", 3/4", 7/8" tube or 1/2" wall thickness pipe insulation with 1-1/8" tube)
TGS-510-W	(Fits: 1" wall thickness pipe insulation with 3/4", 7/8" tube or 3/4" wall thickness pipe insulation with 1-1/8" tube)

Airex Part Number	Model TSS: Siding, Compact Applications
TSS-550-W	(Fits: 1/2" wall thickness pipe insulation with 5/8", 3/4", 7/8" tube)
TSS-575-W	(Fits: 3/4" wall thickness pipe insulation with 5/8", 3/4", 7/8" tube or 1/2" wall thickness pipe insulation with 1-1/8" tube)

TITAN OUTLET™ Color Options



Substitute (G) with (W) for White

Refrigeration Pipe Penetration Detail

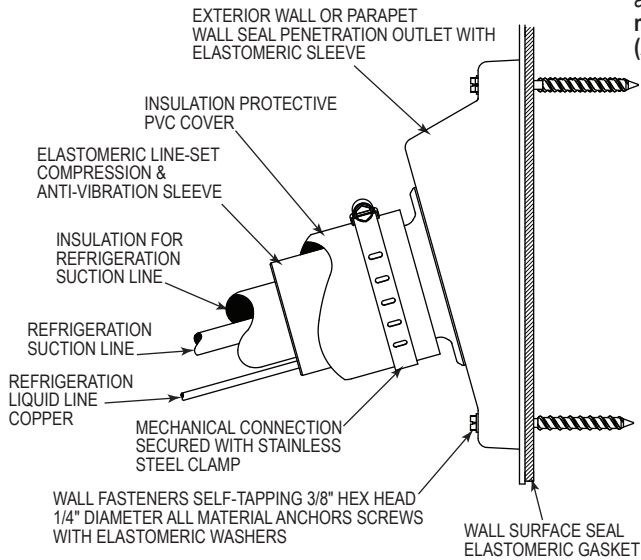

Product Description and Specification

AIREX TITAN OUTLET™ - A wall outlet seal by Airex Manufacturing Inc., shall be provided and installed with its compression gasket mounting method and must be fastened to wall surface with supplied ICC-ES listed and approved non-corrosive screws with pre-loaded neoprene washers. Wall Outlet must also integrate an over-molded, flexible, elastomeric sleeve for sealing, supporting and isolating refrigerant pipes to also control vibration. The Wall Outlet shall also feature outdoor-rated durability and shall provide wall expansion and contraction protection features achieved by gaskets and seals as per energy code requirements. A stainless steel clamp must be utilized to create a "Mechanical Connection" between wall seal and pipe insulation protector as intended per energy codes to allow removable/reusable maintenance capabilities and designed to co-act with the AIREX E-FLEX GUARD™ Pipe Insulation Protection Cover. Wall Outlet seal and insulation protector must both be sustainably and securely installed, mechanically fastened together as one, due to piping vibration, and shall be assembled without the use of adhesives or adhesive tapes as per energy code requirements. **Wall Outlet shall be tested and must meet the following testing: ASTM E 331 (Water Penetration), ASTM E 283 (Air Leakage), and ASTM E 2178 - Air Permeance of Building Materials.**

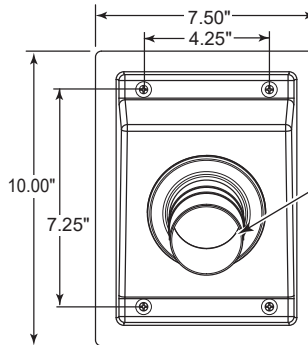

TGS Model Series Sleeve Diameters

Airex Part Number	Sleeve Diameter	Insulation Thickness
TGS-550-W	1.70"	1-11/16"
TGS-575-W	2.375"	2-3/8"
TGS-510-W	3.1875"	3-3/16"

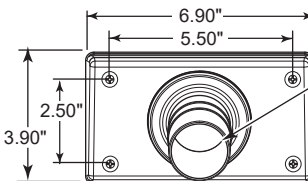

TSS Model Series Sleeve Diameters

Airex Part Number	Sleeve Diameter	Insulation Thickness
TSS-550-W	1.70"	1-11/16"
TSS-575-W	2.375"	2-3/8"

Approved Material & Performance Testing

Product Performance Testing	Plastic Material Testing
<ul style="list-style-type: none"> • ASTM E283 - Standard Test Method for Air Leakage • ASTM E331 - Standard Test Method for Water Penetration of Exterior Walls by Uniform Static Air Pressure • ASTM E 2178 - Air Permeance of Building Materials 	<p>Wall Mounted Outlet (Rigid Plastic)</p> <ul style="list-style-type: none"> • ASTM D1525C-09 - Temperature Deformation Test • ASTM D648-07 - Temperature Load Deformation Test • UL 94 HB - Flammability Test • UL 746C - Outdoor Suitability - f1 Rating <p>Wall Outlet Sleeve (Elastomeric Plastic)</p> <ul style="list-style-type: none"> • ASTM D573-04 - Deterioration Test • ASTM D746-07 - Brittleness Temperature Impact

U.S. Patents #9,091,377 B2, #9,523,200 B2

