

HE Plus

Electronic Whole-House Air Cleaners



PRODUCT DATA SHEET



How Electronic Air Cleaners Work:

The *HE Plus* Electronic House Air Cleaner uses a high-voltage ionizer within the air cleaner that electrically charges airborne pollutants and particles. TRION® electronic air cleaners feature electrostatic precipitators - a series of metal collection plates that are oppositely charged to the ionized particles. The negative filter plate then attracts and captures these microscopic particles, preventing them from being recirculated in the home. TRION® systems offer high performance and efficiency, ultra-quiet operation and no filters to replace.

Features & Benefits:

- The strongest, most reliable power supply and the sturdiest cell in the industry – recognized by dealers nationwide.
- Forever Filter® never needs replacing – just clean and reuse.
- Connects directly to all types of heating and cooling systems.
- Permanent, washable aluminum collection cells deliver longer service life and are easy to clean.
- Greater overall HVAC system efficiency because units keep cooling coils clean.
- Electronic Airflow Sensor: Automatically senses air movement within the duct, resulting in reduced power usage.
- Built-In Internal Fuse: Protects the 24v transformer in the event of a power supply failure.
- All units are UL/C-UL Listed and are easily converted to 240v.
- Rugged cabinet construction for long life.
- Optional Charcoal After-Filter reduces common household odors.

Electronic Air Cleaning Process:

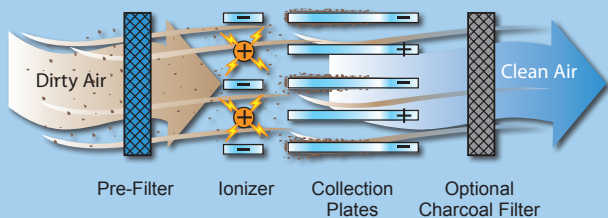

Performance:

- Rated airflow up to 2000 CFM.
- Tested in accordance with ANSI/ASHRAE 52.1-1992.
- Aluminum mesh pre-filter traps large particles such as dirt, lint, and pet hair.
- Minimal Pressure Drop: Less than 0.02 W.G. at rated airflow.

Warranty:

- 5-Year Limited Warranty.



PRODUCT DATA SHEET

HE Plus Dimensions

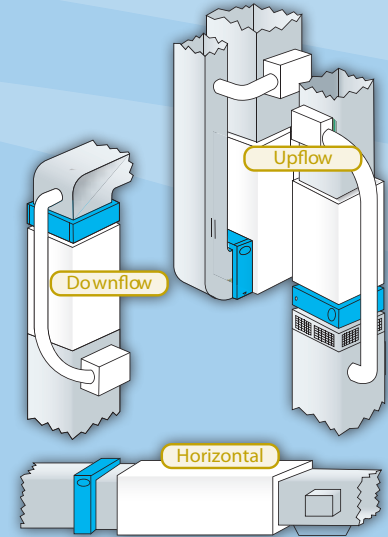
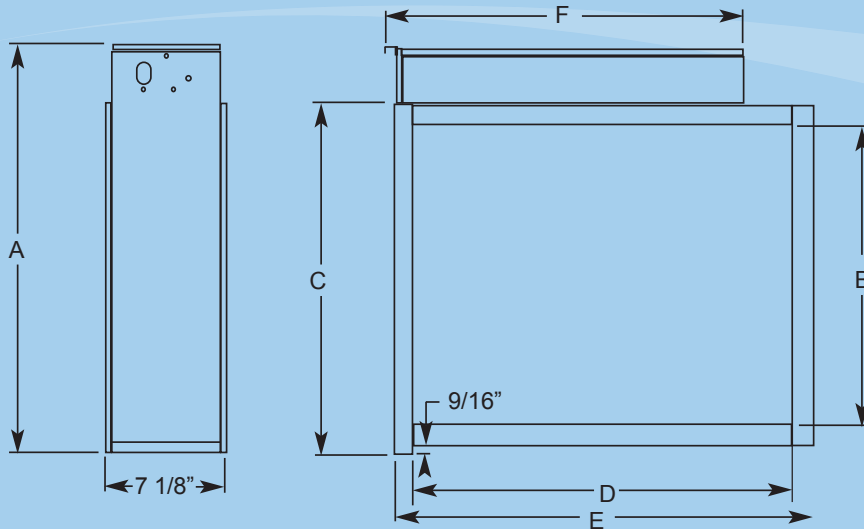

Model	HE PLUS 1400	HE PLUS 2000
Part No. (white)	455600-125	455600-025
Part No. (grey)	455600-129	455600-029
Max. Capacity	1400 CFM	2000 CFM
Cell Weight	(2) 10 lbs each	(2) 12 lbs each
Shipping Weight	36 lbs	42 lbs
Electrical Input	120 V, 50 Hz / 60 Hz, 1 ph	120 V, 50 Hz / 60 Hz, 1 ph
Electrical Output	2.5 MADC	3.2 MADC
Dimensions		
A	20 1/4"	24 1/4"
B	13 7/8"	17 7/8"
C	16 15/16"	20 15/16"
D	22 1/2"	22 1/2"
E	24 7/8"	24 7/8"
G	21 7/16"	21 7/16"

Indoor Air Quality Since 1947.

ISO 9001:2008 Certified.

Industry Memberships:



Proudly Designed,
Engineered, and
Manufactured in the USA.*



*Manufactured with domestic
and foreign components.

To help serve you better,
please contact us at:

800-884-0002 (tel)

800-458-2379 (fax)

TRION[®]

101 McNeill Road
Sanford, NC 27330

www.trioniaq.com

customerservice@trioniaq.com

TRION[®] is a registered trademark of Air System Components, Inc. Air System Components, Inc. is a subsidiary of Johnson Controls Inc. All product specifications reflect available information at the printing of this brochure. TRION[®] reserves the right to revise or modify products and/or specifications without notice. © 2015 TRION[®]