

**2-PIPE
VARIABLE SPEED**



VMB Series **Variable Speed** **2-Pipe Hydronic Fan Coils** 1.5 - 5.0 Tons **Cooling**



The **VMB** Series includes a programmable, high efficiency motor that redefines comfort and energy savings. The **VMB** motor automatically adjusts its torque and speed to maintain a preprogrammed level of constant airflow over a wide range of external static pressures. This variable speed technology offers better indoor air quality, more precise humidity control, quieter operation, consistent indoor air temperature, and lower utility bills.

High Efficiency - At full load conditions the **VMB** motor is 20% more efficient than an induction motor and at constant fan speed it consumes only 60-80 watts of power compared to 400 watts for a standard induction motor.

Quiet Operation - The versatile **VMB** motor quietly “ramps up” when the unit is turned on and “ramps down” when the thermostat is satisfied, eliminating the annoying sounds of changing airflow.

Self-Regulating Constant Airflow - The **VMB** motor is factory programmed to maintain a predetermined level of airflow over a wide range of external static pressures, ensuring optimum system performance and whole-house comfort. The benefits of constant fan operation are:

- **Consistent air distribution** (and temperature) throughout the home
- **Better indoor air quality** (further improved with the addition of high efficiency filter) - This allows the air to be filtered without excessive drafts and without sacrificing efficiency.
- **Better humidity control** - The **VMB** is designed to extract much more moisture from the air than a conventional system by slowing the airflow over the cooling coil. The result is an improved summer comfort level at higher indoor temperatures.

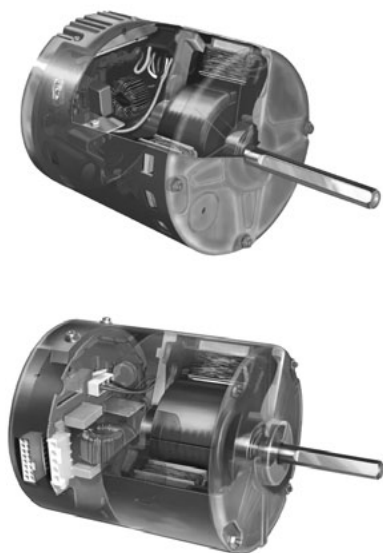

Variable Speed ECM Motor

Additional Standard Features:

- Vertical/horizontal drain pans
- Attractive baked-on powder coat finish
- Fully insulated cabinet
- Primary and secondary drain connections on cooling coil
- 120V motor, 24V control
- Compatible with most properly sized and installed zone control systems.
Contact the zone control manufacturer.
- High efficiency pleated filter(s)

VMB Series Cooling / Heating (2-pipe)

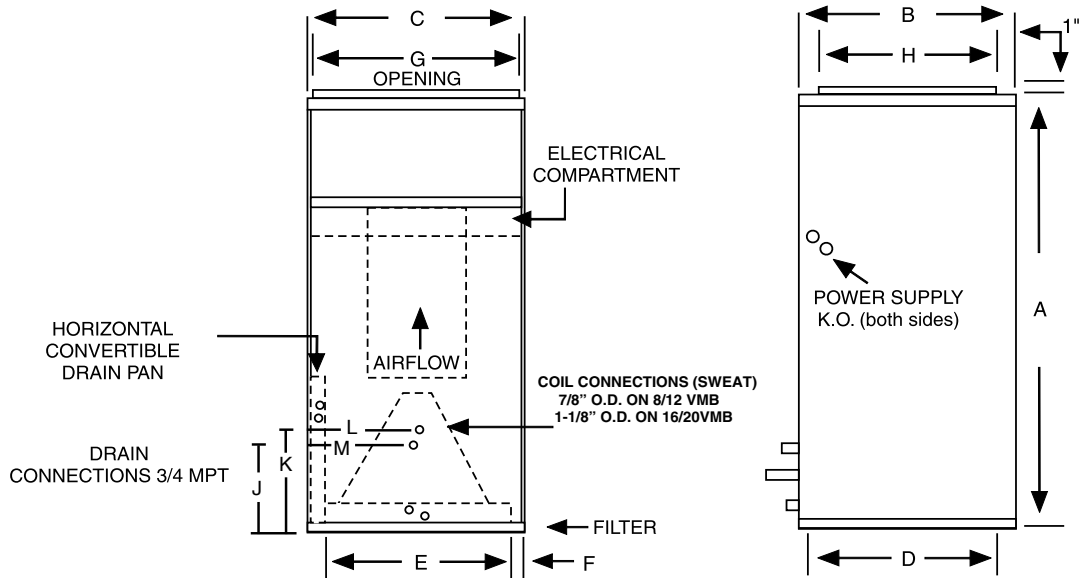

PHYSICAL DIMENSIONS														
UNIT MODEL	A	B	C	D	E	F	G	H	J	K	L	M	COIL CONNECTIONS	FILTER SIZE
8VMB	40	20	20	18-1/2	16	2	18	16	4-1/8	8	11-1/8	9-7/8	7/8 SWEAT	18 X 20 X 1
12VMB	42	23	20	21-1/2	16	2	18	17	6-1/4	10-9/16	11-1/8	9-7/8	7/8 SWEAT	20 X 22 X 1
16/20VMB	48	28	21-1/4	26-1/4	17-1/4	2	19-1/4	18	4-3/8	7-9/16	11-7/8	10-5/8	1-1/8 SWEAT	20 X 25 X 1

ELECTRICAL DATA				
UNIT MODEL	MOTOR HP (120V)	MOTOR AMPS	MIN. CIR. AMPACITY	MAX. HACR BREAKER
8VMB	1/3	4.8	6.0	15
12VMB	1/2	7.3	10	15
16VMB	3/4	10.5	14	15
20VMB	1	11.5	15	15

- Features:**
1. Variable speed motor
 2. Vertical / Horizontal drain pan (right-to-left and left-to-right airflow)
 3. Manual air vent
 4. Pleated filter(s)

AIR FLOW DATA									
MODEL	OPERATING MODE	CONTROL BOARD SELECTION TAPS							
		COOL (CFM) (2)				HEAT (CFM) (1)			
		A	B	C	D	A	B	C	D
8VMB	COOLING or HEATING THERMOSTAT SIGNAL					800	700	600	500
	CONTINUOUS BLOWER	400	350	300	250				
12VMB	COOLING or HEATING THERMOSTAT SIGNAL					1200	1050	900	750
	CONTINUOUS BLOWER	600	525	450	375				
16VMB	COOLING or HEATING THERMOSTAT SIGNAL					1600	1400	1200	1000
	CONTINUOUS BLOWER	800	700	600	500				
20VMB	COOLING or HEATING THERMOSTAT SIGNAL					1825	1700	1600	1400
	CONTINUOUS BLOWER	900	850	800	700				



For additional sales and technical information on variable speed motors, visit www.thedealertoolbox.com

NOTES:

1. The HEAT select tap controls the maximum CFM in both heating and cooling modes.
2. The COOL select tap only controls the CFM when fan switch on thermostat is set to "ON" (continuous blower).
3. The COOL and HEAT taps are factory set on "A"

Digital thermostats for these units must have a "C" terminal.

Airflow shown are dry coil at 120 volts.
Max. ext. static pressure is 0.50" wtr

NOTES:

The cooling and heating speed taps are factory set on "A".
The delay profile is factory set on "Arid" setting.
The adjust profile is factory set on "Normal:"
Adjust profile (+) will increase airflow by 10%, while tap (-) will decrease airflow by 10%

In keeping with its policy of continuous progress and product improvement, First Operations reserves the right to make changes without notice.
Maintenance for all First Co. products is available under "Product Maintenance" at www.firstco.com.

COOLING PERFORMANCE DATA															
UNIT MODEL	NOM. CFM	GPM	P.D. (FT. WTR.)	45°F ENTERING WATER						42°F ENTERING WATER					
				80°F DB/67°F WB ENT. AIR			75°F DB/63°F WB ENT. AIR			80°F DB/67°F WB ENT. AIR			75°F DB/63°F WB ENT. AIR		
				TOTAL MBH	SENS. MBH	TEMP. RISE	TOTAL MBH	SENS. MBH	TEMP. RISE	TOTAL MBH	SENS. MBH	TEMP. RISE	TOTAL MBH	SENS. MBH	TEMP. RISE
8VMB	600	3.0	2.5	19.0	13.8	12.7	14.5	12.1	9.7	20.7	14.4	13.8	15.8	12.6	10.5
		4.5	5.5	22.4	15.1	9.9	17.1	13.1	7.6	24.4	15.9	10.8	18.6	13.7	8.3
		6.0	9.5	24.4	15.9	8.2	18.7	13.7	6.2	26.6	16.8	8.9	20.3	14.4	6.8
	800	3.5	3.4	23.1	17.3	13.2	17.6	15.2	10.1	25.2	18.1	14.4	19.2	15.8	11.0
		5.0	6.7	26.9	18.7	10.7	20.5	16.3	8.2	29.3	19.6	11.7	22.4	17.1	8.9
		6.5	11.0	29.2	19.6	9.0	22.3	17.0	6.9	31.8	20.6	9.8	24.3	17.8	7.5
12VMB	1000	4.0	2.4	28.3	21.6	14.1	21.6	19.0	10.8	30.8	22.5	15.4	23.6	19.7	11.8
		6.0	4.8	33.9	23.7	11.3	25.9	20.6	8.6	36.9	24.8	12.3	28.2	21.6	9.4
		8.0	7.9	37.3	25.0	9.3	28.5	21.7	7.1	40.6	26.3	10.2	31.0	22.7	7.8
	1200	5.0	3.5	33.7	25.5	13.5	25.8	22.4	10.3	36.8	26.6	14.7	28.1	23.3	11.3
		6.5	5.5	38.0	27.1	11.7	29.1	23.7	8.9	41.5	28.4	12.8	31.7	24.7	9.7
		8.0	7.9	41.0	28.2	10.3	31.3	24.6	7.8	44.7	29.6	11.2	34.1	25.7	8.5
16VMB	1400	4.5	2.0	36.2	29.2	16.1	27.7	25.8	12.3	39.5	30.3	17.6	30.1	26.7	13.4
		6.0	3.3	42.4	31.4	14.1	32.4	27.6	10.8	46.2	32.8	15.4	35.3	28.7	11.8
		7.5	4.8	46.9	33.1	12.5	35.8	28.9	9.6	51.1	34.7	13.6	39.0	30.2	10.4
	1600	6.0	3.3	44.2	34.1	14.7	33.8	30.0	11.3	48.2	35.5	16.1	36.8	31.2	12.3
		8.0	5.4	51.0	36.6	12.7	38.9	32.0	9.7	55.5	38.3	13.9	42.4	33.4	10.6
		10.0	7.9	55.7	38.4	11.1	42.5	33.4	8.5	60.7	40.3	12.1	46.3	34.9	9.3
20VMB	1600	6.5	3.8	46.1	34.8	14.2	35.2	30.6	10.8	50.3	36.3	15.5	38.4	31.8	11.8
		8.5	6.0	52.3	37.1	12.3	39.9	32.4	9.4	57.0	38.8	13.4	43.5	33.8	10.2
		10.5	8.6	56.6	38.7	10.8	43.2	33.7	8.2	61.7	40.7	11.8	47.1	35.2	9.0
	2000	7.0	4.3	52.4	40.9	15.0	40.0	36.1	11.4	57.1	42.6	16.3	43.6	37.4	12.5
		10.0	7.9	61.7	44.3	12.3	47.1	38.8	9.4	67.3	46.4	13.5	51.4	40.5	10.3
		13.0	12.5	67.5	46.5	10.4	51.6	40.5	7.9	73.6	48.8	11.3	56.2	42.4	8.6

HEATING PERFORMANCE DATA							
UNIT MODEL	NOM. COOLING BTUH	NOM. CFM	GPM (HTG)	P.D. (FT. WATER)	BTUH (1000) AT ENTERING WATER TEMPERATURE		
					140°F	160°F	180°F
8VMB	18,000/ 24,000	800	6.0	9.5	45.5	58.5	*
			4.5	5.5	43.5	56.0	68.4
			3.0	2.5	40.4	52.0	63.5
		700	6.0	9.5	41.4	53.3	*
			4.5	5.5	39.7	51.1	*
			3.0	2.5	37.0	47.6	58.2
		600	4.0	4.4	35.1	45.1	*
			3.0	2.5	33.5	43.0	*
			2.0	1.2	31.0	39.8	48.7
		500	4.0	4.4	30.9	39.8	*
3.0	2.5		29.6	38.0	*		
2.0	1.2		27.6	35.5	43.4		
12VMB	30,000/ 36,000	1200	8.0	7.9	66.6	85.7	104.7
			6.5	5.5	66.4	85.3	104.3
			5.0	3.6	61.5	79.0	96.6
		1050	8.0	7.9	60.7	78.1	*
			6.5	5.5	58.9	75.7	*
			5.0	3.6	56.3	72.4	88.5
		900	6.0	4.8	52.3	67.3	*
			4.5	3.0	49.8	64.1	78.3
			3.0	1.5	48.0	61.8	75.5
		750	6.0	4.8	46.1	59.2	*
			4.5	3.0	44.1	56.7	*
			3.0	1.5	41.1	52.9	64.6
16VMB	42,000/ 48,000	1600	10.0	8.0	90.6	116.5	*
			8.0	5.4	87.3	112.3	137.2
			6.0	3.3	82.7	106.3	129.9
		1400	10.0	8.0	82.7	106.3	*
			8.0	5.4	79.8	102.6	*
			6.0	3.3	75.8	97.4	119.1
		1200	6.0	3.3	68.5	88.0	*
			5.0	2.4	66.2	85.2	104.1
			4.0	1.6	63.4	81.6	99.7
		1000	6.0	3.3	60.7	78.1	*
			5.0	2.4	58.9	75.8	*
			4.0	1.6	56.6	72.8	*
20VMB	48,000/ 60,000	2000	13.0	12.5	110.2	141.7	173.2
			10.0	8.0	105.9	136.1	166.4
			7.0	4.3	99.1	127.4	155.7
		1800	13.0	12.5	102.2	131.4	*
			10.0	8.0	98.3	126.3	154.4
			7.0	4.3	92.0	118.2	144.5
		1600	9.0	6.6	89.1	114.5	*
			7.0	4.3	85.2	109.6	133.9
			5.0	2.4	79.6	102.3	125.0
		1400	9.0	6.6	81.3	104.6	*
			7.0	4.3	78.0	100.2	*
			5.0	2.4	73.1	94.0	114.9

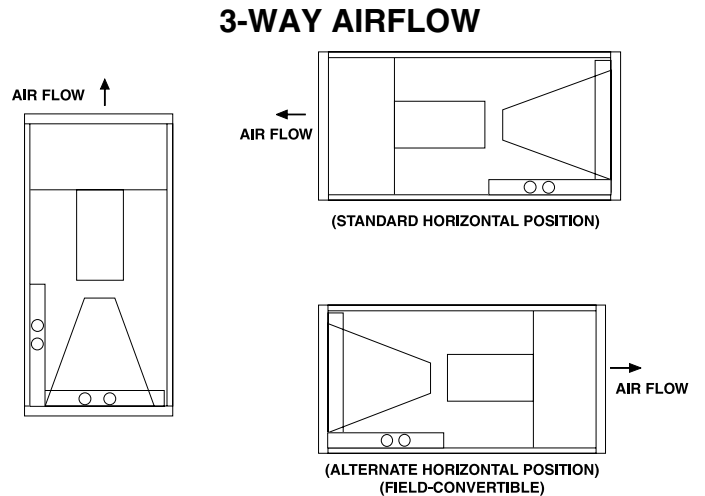

- NOTES:**
- (1) Heat BTU is at 70° Entering Air Temperature.
 - (2) * Capacity exceeds the leaving air temperature maximum

General Construction Features

Basic Unit

All models are manufactured with heavy gauge galvanized steel to resist corrosion.

Each cabinet is fully insulated.

Coil connections are stubbed out the cabinet for easier installation.

Coils

Coils have 3/8 inch copper tubing expanded to high efficiency aluminum fins. Manual air vents are provided and all coils are pressure tested to 350 psig.

Drain Pans

All fan coils can be installed vertically or horizontally (right-to-left airflow) with no modification. Horizontal drain pans can be repositioned within the cabinet to allow horizontal installation with left-to-right airflow. Each drain pan is coated with to reduce corrosion.

Threaded primary and secondary drain connections are also provided.

Motors

Standard motors are variable speed type with internal thermal overload protection and are mounted with rubber isolation bushings.

Blower wheels are centrifugal, forward curved, and dynamically balanced.

Filters

One inch pleated filters are factory installed.

Agency Listing

All standard models are ETL Listed.



ACCESSORIES: (field installed) (all components mount outside the cabinet)	
POWER HEADS:	
E50131180	24V
SEPARATE VALVE BODIES: (order power heads separately)	
E421317	3/4" 2-way - For 8-12VMB
E431317	3/4" 3-way - For 8-12VMB
E421417	1" 2-way - For 16-20VMB
E431417	1" 3-way - For 16-20VMB
HAND VALVES: (Combination balance / shut-off) (2 usually req'd per coil)	
CP90	3/4" - For 8-12VMB
CP905	1" - For 16-20VMB

NOTE:

1. Power head leads are 18".

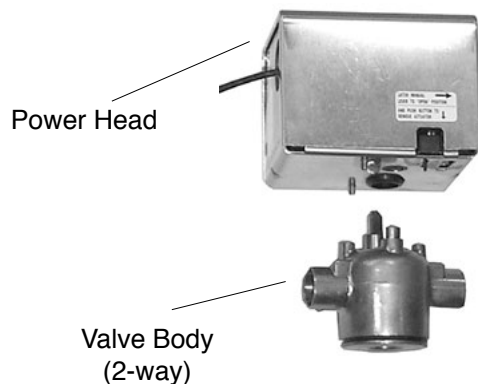

Catalog No. **VMB819** (replaces VMB611)