

# USERS INFORMATION MANUAL

**MULTI-POSITION, UPFLOW, AND HORIZONTAL DX AND CHILLED WATER COOLING WITH ELECTRIC OR HOT WATER HEATING MODELS: MS, MM, US, UM SERIES**

**For Installation In:**  
**1. Modular Homes & Buildings**  
**2. Residential Homes**

## LIST OF SECTIONS – USERS INFORMATION MANUAL

1 – General	1	4 – Start Up & Shutdown Instructions	5
2 – Safety	2	5 – Owner Maintenance	5
3 – Owners Information & Seasonal Information	3		

## LIST OF SECTIONS – SERVICE AND MAINTENANCE MANUAL

1 – Safety	8	6 – Blower Performance	16
2 – Air Handler Maintenance	9	7 – ECM 2.3 Climate Profiles	20
3 – Air Handler Controls	10	8 – Accessories Parts	21
4 – Sequence of Operation	10	9 – Replacement Parts	22
5 – Troubleshooting	13		

## LIST OF FIGURES

1 – Air Handler Examination Check Points	4	15 – ECM Motor Control Pin Out	14
2 – Front Access Panel Circuit Breaker Locations	5	16 – Adjustable Time Delay Relay (TDR) Terminals	14
3 – Home Owner / Users Cleaning Points	6	17 – X-13 Motor Terminals	14
4 – Accessory Air Filter Box – Upflow	6	18 – Heater Relay Terminal Designations	15
5 – Accessory Air Filter Box – Air Filter Access - Upflow	6	19 – Blower Mounting Plate and Screw Locations	15
6 – Accessory Filter Box – Adjustment for 1” and 2” Filters	6	20 – ECM Control Board Diagram	19
7 – Downflow / Horizontal Filter Location – Wall or Ceiling	7	ECM Climate Profiles figure 1 and figure 2	20
8 – No Electric Heat Control Box	9	21 – MS 18-24 Electric Heat Replacement Parts Drawing	22
9 – Hydronic Heat Control Box	9	22 – MS 25-30-36 Electric Heat Replacement Parts Drawing	23
10 – Electric Heat Control Box	9	23 – MS 37-42-48-60-72 Electric Heat Replacement Parts Drawing	24
11 – Blower Assembly and Mounting Screw Location	9	24 – MS 18-24 Hydronic Heat Replacement Parts Drawing	25
12 – Component Locations – Electric Heat Models	11	25 – MS 25-30-36 Hydronic Heat Replacement Parts Drawing	26
13 – Component Locations – Hydronic Heat Models	11	26 – MS 37-42-48-60-72 Hydronic Heat Replacement Parts Drawing	27
14 – Motor Speed Tap Isolation Relay - X-13 and PSC Motors	13		

## LIST OF TABLES

1 – X-13 Motor Terminal Connections	15	10 – Blower CFM - Heat & Cool Jumper Pin Taps ECM Cntrl Board	19
2 – 208 / 240 VAC Blower Motor Current Chart	15	11 – MSVE, MSVT, MSPS Accessory Parts List	21
3 – 120 VAC Blower Motor Current Chart	15	12 – MS 18-24 Electric Heat Replacement Parts List	22
4 – MSVE Blower Performance - ECM 2.3 Motor	16	13 – MS 25-30-36 Electric Heat Replacement Parts List	23
5 – MSVE Blower Amp Data - ECM 2.3 Motor	16	14 – MS 37-42-48-60-72 Electric Heat Replacement Parts List	24
6 – MSVT Blower Performance – X-13 Motor	17	15 – MS 18-24 Hydronic Heat Replacement Parts List	25
7 – MSVT Blower Amp Data – X-13 Motor	17	16 – MS 25-30-36 Hydronic Heat Replacement Parts List	26
8 – MSPS Blower Performance – PSC Motor	18	17 – MS 37-42-48-60-72 Hydronic Heat Replacement Parts List	27
9 – MSPS Blower Amp Data – PSC Motor	18		

## CONTACT INFORMATION

Contact us by mail: Manufactured and Distributed by

Mortex Products Inc.  
 501 Terminal Rd  
 Fort Worth, TX 76106

[www.mortx.com](http://www.mortx.com)

## SECTION I: GENERAL

The following list includes important facts and information regarding the air handler and its inclusions.

1. Air Handler is rated at 240 volts AC at 60 Hertz for electric heat models or 120 volts AC at 60 Hertz for hydronic models.
2. Air Handler is available in a small, medium, or large cabinet size.
3. All air handlers are equipped with a blower for A/C or Heat Pump operation.
4. Multi-position models are designed for upflow, downflow and horizontal application. All other models are designed for upflow and horizontal application.
5. This air handler must not be operated without the doors installed.

NOTE: This air handler and its components are listed as a combination AC or Heat Pump system by ETL for sale in the United States and Canada.

**▲ WARNING**

**FIRE OR ELECTRICAL HAZARD**

Failure to follow the safety warnings exactly could result in serious injury, death, or property damage. A fire or electrical hazard may result causing property damage, personal injury or loss of life.

Do not store or use gasoline or other flammable vapors and

**USERS MUST READ ALL INSTRUCTIONS IN THIS MANUAL AND THIS MANUAL MUST BE SAVED FOR FUTURE REFERENCE**

## SECTION II: SAFETY



This is a safety alert symbol. When you see this symbol on labels or in manuals; be alert to the potential for personal injury.

Understand and pay particular attention to the signal words **DANGER**, **WARNING**, or **CAUTION**.

**DANGER:** indicates an **imminently** hazardous situation, which if not avoided, **will result in death or serious injury.**

**WARNING:** indicates a **potentially** hazardous situation, which if not avoided, **could result in death or serious injury.**

**CAUTION:** indicated a **potentially** hazardous situation, which if not avoided, **may result in minor or moderate injury.** It is also used to alert against unsafe practices and hazards involving property damage.

### **WARNING**

Any adjustment, service or maintenance by the home owner and/or user may create a condition where the operation of the product could cause personal injury or property damage.

Only qualified service personnel, a contractor, or an installer may refer to the service and maintenance section of this manual for assistance or for additional information on this appliance.

### **CAUTION**

This product requires periodic routine maintenance and cleaning of the exterior surfaces by the homeowner or user to remove dust and debris. Any additional service must be performed by qualified personnel. This appliance must be serviced and maintained as specified in these instructions and/or to any applicable local, state, and national codes including, but not limited to building, electrical, and mechanical codes.

### **WARNING**

#### **FIRE OR ELECTRICAL HAZARD**

Failure to follow the safety warnings exactly could result in serious injury, death, or property damage.  
A fire or electrical hazard may result causing property damage, personal injury or loss of life.

## SAFETY REQUIREMENTS

1. This air handler must be kept clear and free of combustible materials, gasoline and other flammable vapors and liquids.
2. Insulating materials may be combustible. The air handler must be kept free and clear of insulating materials. The air handler area must be examined when installed in an insulated space or when insulation is added to be sure that the insulation material has been kept away from the appliance.
3. Follow the instructions exactly as shown in Startup and Shutdown Section in this manual to properly Startup or Shutdown this appliance.
4. If overheating occurs, turn off the power to the appliance and contact a qualified contractor, installer, or service agency.

### **DANGER**

Do not use this appliance if any part has been under water. A flood damaged furnace is extremely dangerous. Attempts to use the air handler can result in a fire.  
A qualified contractor, installer, or service agency must be contacted to inspect the air handler for any water damage and replace all components, control system parts, or electrical parts that have been damaged. If enough damage is present, the air handler may need to be replaced.

5. NEVER - Store flammable materials of any kind near your appliance. Gasoline, solvents and other volatile liquids should be stored only in approved containers outside the home. These materials vaporize easily and are extremely dangerous.
6. NEVER – Store cleaning materials such as bleaches, detergents, powder cleaners, etc. near the appliance. These chemicals can cause corrosion of the air handler sheet metal and the electric heaters, the blower and the electrical controls.
7. NEVER – Use the area around the appliance as a storage area for items which could block or obstruct the normal air flow to the air handler or the space around the appliance. The flow of air is required for safe and proper operation. Never block or obstruct air openings used for ventilation and cooling of the air handler electrical components.
8. Refer to the appliance rating plate for the air handler model number, for the operating specifications for safe operation.
9. Provide clearances for servicing ensuring service access is allowed for the control box, electric elements and the blower.
10. Failure to carefully read and follow all instructions in this manual can result in malfunction of the air handler, death, personal injury, and/or property damage.
11. If the air handler is installed in a residential garage it must be installed so that the electric heaters are located not less than 18 inches above the floor and the air handler must be

located or protected to avoid physical damage by vehicles.



### **FIRE OR ELECTRICAL HAZARD**

Servicing heating/cooling equipment can be hazardous due to electrical components.

Only trained and qualified personnel can service or repair heating/cooling equipment. The home owner **must never** try to perform service, repair or maintenance on this appliance.

**Untrained service personnel can perform only basic maintenance functions such as cleaning of exterior surfaces and replacing the air filters.**

Observe all precautions in the manuals and on the attached labels when working on this appliance

12. These instructions cover minimum requirements and conform to existing national standards and safety codes. In some instances these instructions exceed certain local codes and ordinances, especially those who have not kept up with changing modular home and residential home construction practices. These instructions are to be followed and are the minimum requirement to perform service or repairs on this appliance.

## **SECTION III: OWNERS INFORMATION AND SEASONAL INFORMATION**

### **How The Air Handler Works – Heating Cycle**

The appliance is equipped with the controls necessary for proper and safe operation. Circuit breaker location is shown in Figure 1.

The air handler is equipped with a relay(s), time delay relay, transformer, circuit breakers (Electric Heat Models Only), and a blower assembly. The transformer provides 24 VAC to the thermostat.

When the thermostat calls for heat on the electric heat models, the relay(s) energize sending 240 VAC thru the limit switches to the electric heaters causing them to get hot. The indoor fan motor is then energized on the selected heating speed tap after an "ON" time delay and the circulating blower draws cool air from the living space(s), passes it across the heater coils and circulates the warmed air through the duct work to the living space(s). When the thermostat is satisfied the electric heaters are de-energized. The blower is also de-energized after an "OFF" time delay and the heating cycle has ended and the air handler is ready for the next call for heat to start the next cycle.

When the thermostat calls for heat on the hydronic heating models a pump relay will be energized causing the flow of hot water thru the hot water coil, heating the coil. The indoor fan motor is energized on the heating speed tap after an "ON" time delay. The circulating blower then draws cool air from the living space(s), passes it across the hot water coil and circulates the warmed air through the duct work to the living

space(s). When the thermostat is satisfied the circulating pump is de-energized. The blower is also de-energized after an "OFF" time delay, the heating cycle has ended and the air handler is ready for the next call for heat to start the next cycle.

### **How The Air Handler Works – Cooling Cycle**

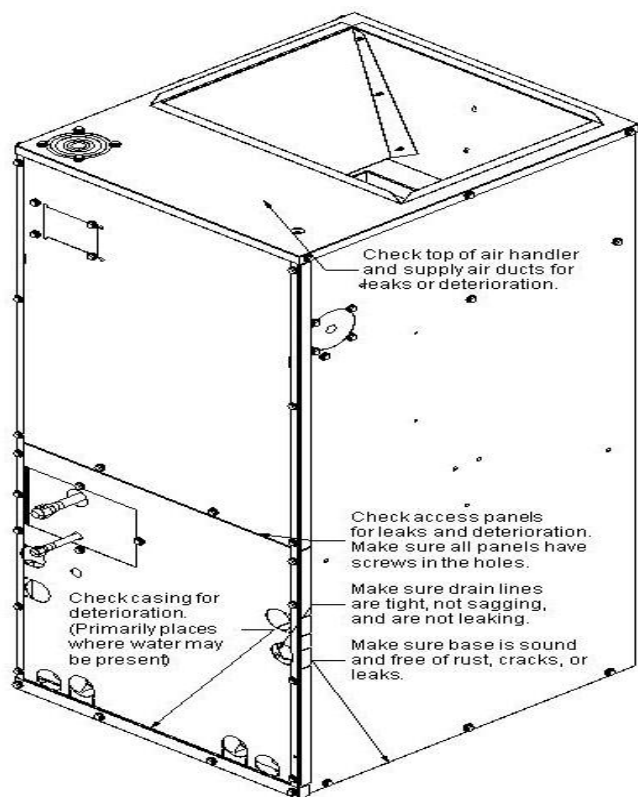
When the thermostat calls for cooling, 24 VAC is sent to the compressor contactor causing it to close energizing the compressor and the outdoor fan motor. The indoor fan motor is then energized on the selected cooling speed tap after an "ON" time delay and the circulating blower draws air from the living space(s), passes it across the cooling coil in the air handler and circulates the cooled air through the duct work to the living space(s). When the thermostat is satisfied the compressor contactor is de-energized turning off the compressor and the outdoor fan motor. The blower is also de-energized after an "OFF" time delay and the cooling cycle has ended and the air handler is ready for the next call for cooling to start the next cycle.

When the thermostat calls for heat pump, 24 VAC is sent to the compressor contactor causing it to close energizing the compressor and the outdoor fan motor. The reversing valve is energized causing the flow of the refrigerant to reverse and heat the coil inside the air handler. The indoor fan motor is then energized on the selected heat pump speed tap after an "ON" time delay and the circulating blower draws air from the living space(s), passes it across the coil in the air handler and circulates the warmed air through the duct work to the living space(s). When the thermostat is satisfied the compressor contactor is de-energized turning off the compressor and the outdoor fan motor. The blower is also de-energized after an "OFF" time delay and the heat pump cycle has ended and the air handler is ready for the next call for heat pump to start the next cycle.

### **Examination of the air handler**

The home owner should perform a visual examine the furnace every month for any defects or problems. The items to be inspected are:

1. The physical support of the furnace is sound without sagging cracks, gaps, etc. around the base so as to provide a seal between the support and the base.
2. The furnace casing for any obvious signs of deterioration from rust or corrosion.
3. The return and supply duct connections are physically sound and are sealed to the furnace casing.
4. The furnace must be serviced by qualified personnel annually, preferably at the start of each heating season.



**Figure 1: Air Handler Visual Check Points**

### The Service Technician

The air handler's best friend is a qualified service technician. If the appliance gives any indication of improper operation, call the service technician. The service technician is allowed to perform the normal routine care of your appliance. He can detect potential problems and make corrections before trouble develops. Preventative maintenance of this type will allow the air handler to operate with minimal concerns to the homeowner and will add years of comfort.

### Warranty and Responsibilities

It is the sole responsibility of the homeowner to make certain the furnace has been properly installed and adjusted to operate properly.

The manufacturer warrants the appliance to be free from defects in material or workmanship for a stated time in the warranty agreement. The manufacturer will not be responsible for any repair costs to correct problems due to improper setup, improper installation, improper furnace adjustments, installing parts or components on the appliance that are not listed for use with this appliance, improper operating procedures by the user or repairs performed by the appliance user or owner.

Some specific examples of service calls which will be excluded from warranty reimbursement are:

1. Correcting faulty duct work in the home. This can be due to not enough ducts or ducts are too small to provide proper air flow through the air handler.
2. Correcting electrical wiring problems in the supply wiring to the air handler.
3. Resetting circuit breakers or on/off switches used for servicing.

4. Problems caused by installation and operation of any air conditioning unit, heat pump, or other air quality device which is not approved for use with this air handler.
5. Adjusting or calibrating the thermostat.
6. Problems caused by construction debris which has fallen into the air handler.
7. Replacement of fuses.
8. Problems caused by dirty air filters.
9. Problems caused by restrictions in the return or supply air flow causing low air flow.

The home owner should establish a firm understanding of these responsibilities with the installer or Service Company so there will be no misunderstanding of what will be covered under warranty at a later date.

### While you are away

The air handler is equipped with safety shutoff devices which are designed to prevent the appliance from overheating in case of a malfunction. For this reason it is never practical to assume the appliance will operate unattended for a long period of time. An example of a malfunction that can cause significant damage to the home would be:

If the blower motor fails the heaters will cycle on the safety shutoff devices while the temperature inside your home continues to drop. All of the water pipes will freeze once the temperature falls below 32°F.

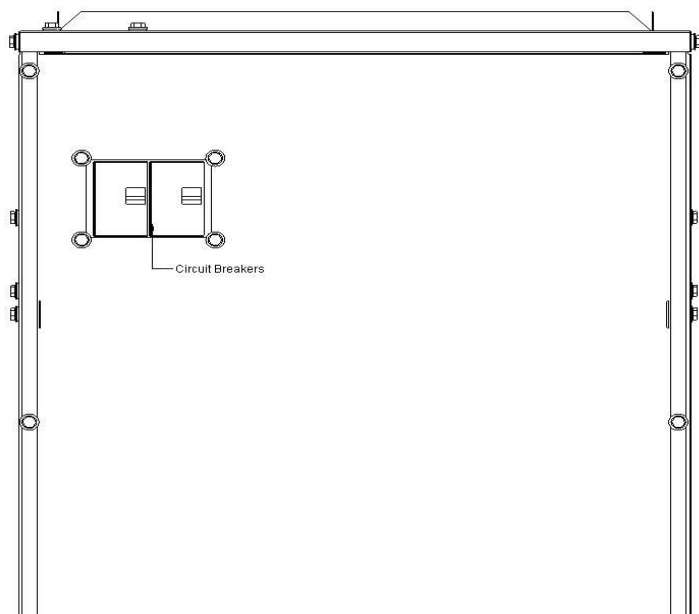
If you are planning to be away from home for a long period of time, have someone check on your home everyday, especially when the outside temperatures will be below 35°F to ensure the air handler is operating properly. This may prevent water pipes from freezing.

### The Furnace Fails to Operate Properly

If any abnormalities are observed while the furnace is operating normally, perform the following checks:

1. Check the setting on the thermostat to make sure the thermostat is set above the room temperature.
2. Check to see if the electrical power is turned on at the circuit breakers at the main service circuit breaker box or check any on/off switches that may be used for service disconnect switches.
3. Check any inline fuses that may have been installed on the air handler to determine if it has blown.
4. Make sure the air filters are clean, return grilles clean, are not obstructed, and supply air registers are open.

If the cause of the malfunction is not obvious do not attempt to service the appliance yourself. Call a qualified service agency/company to repair the appliance.



**Figure2: Front Access Panel Circuit Breaker Locations**

## SECTION IV: STARTUP AND SHUTDOWN INSTRUCTIONS

Read the instructions below before trying to start the appliance.

### **WARNING**

If you do not follow these instructions exactly, a fire may result causing property damage, personal injury, and/or loss of life.

- A. **BEFORE OPERATING;** check around perimeter of the furnace to make sure there are no flammable materials in the area. If you smell vapors of any kind, **DO NOT** turn on the power to the appliance until vapors have been ventilated and removed from the area of the appliance.
- B. **CHECK THE FURNACE;** visually check the appliance for loose screws and/or panels that may be missing or have fallen off.
- C. **CHECK DUCT CONNECTIONS;** visually check the connections of the ducts to the appliance to make sure there are no gaps or holes and ducts are securely fastened to the furnace.

### **Turn On / Start the Appliance**

1. **STOP!** Read the safety information above before proceeding.
2. Set the thermostat to the lowest setting.
3. Turn off all electrical power to the appliance at the main service disconnect box.
4. Remove the upper and lower access door.
5. Turn off the circuit breakers on the appliance control box.
6. Remove the control box cover.
7. Visually check the control box for loose wire connections and faulty or loose components.
8. Visually check the blower compartment for obstructions or loose debris.
9. Replace the control box cover.
10. Turn the circuit breakers to the on position.
11. Replace the upper and lower access door.
12. Turn the circuit breakers in the main service disconnect box to the on position.
13. Set the thermostat to the desired setting.

### **Shutting Down or Turning Off the Appliance**

1. Set the thermostat to the lowest setting.
2. Turn off all electrical power to the appliance at the main service disconnect box.
3. Remove the upper access door.
4. Turn off the circuit breakers on the appliance control box.
5. Replace the upper access door.

## SECTION V: OWNER MAINTENANCE

All appliances need annual maintenance in order to operate properly. The annual service must be performed by qualified service personnel. The homeowner is expected to perform general cleaning of the exterior surfaces and replacement of the air filters. Air filters must be checked every month and replaced as needed. Figures 2 and 3 indicate the location of the air filters.

### **WARNING**

#### **AIR HANDLERS WITH ELECTRIC HEATERS**

Should overheating occur turn the circuit breakers on the control box and the main electrical service entrance (Circuit Breaker Box) to the off position. Call qualified service personnel to troubleshoot and repair the appliance. **DO NOT** allow the air handler to continue to cycle on the limits.

### **When to Call For Service Assistance**

Very often time can be saved if you give a service agency the information about the air handler ahead of time. This will enable the service agency to determine the specific components used and possibly indentify the problem, thus arriving with the parts to fix the problem. Write down the model number, Serial Number and be prepared to describe what the air handler is or is not doing and what you have checked prior to calling.

### **SERVICE AGENCY INFORMATION**

Fill in Below

**MODEL NUMBER:** \_\_\_\_\_

**SERIAL NUMBER:** \_\_\_\_\_

**SERVICE COMPANY:** \_\_\_\_\_

**ADDRESS:** \_\_\_\_\_

**TELEPHONE (DAYTIME):** \_\_\_\_\_

**TELEPHONE (EMERGENCY)** \_\_\_\_\_

**NOTES:** \_\_\_\_\_

\_\_\_\_\_

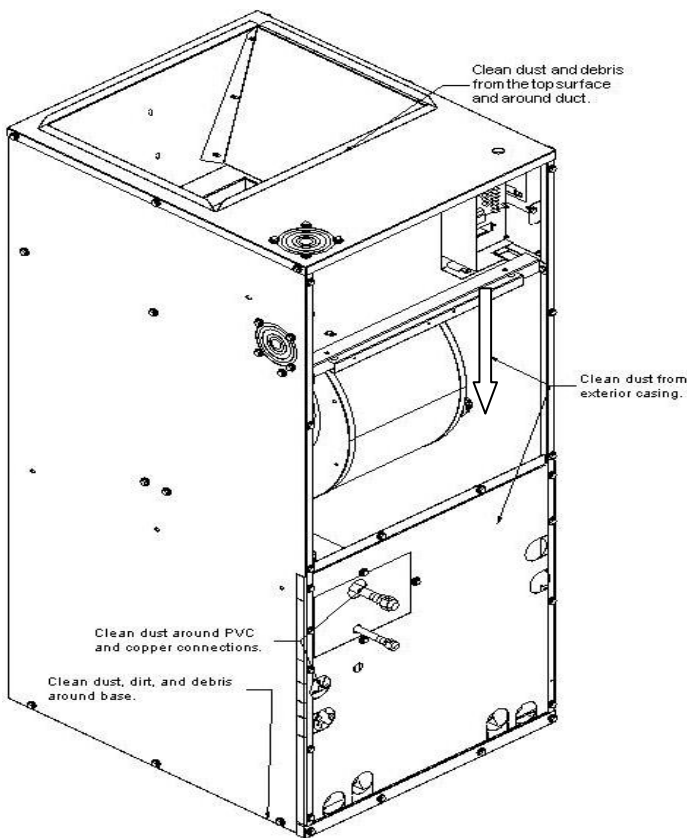
\_\_\_\_\_

\_\_\_\_\_

\_\_\_\_\_

\_\_\_\_\_

\_\_\_\_\_



**Figure 3: Home Owner / Users Cleaning Points**

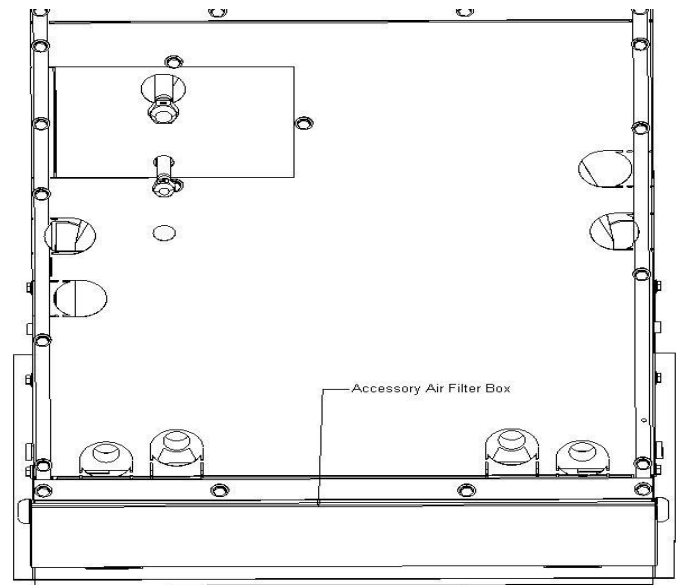
**Upflow Air Filter Replacement – Accessory Filter Box Kit**

Follow these easy steps to replace the air filters.

1. Follow the procedure **“To Turn Off the Appliance”** in the Startup and Shutdown Instructions section of these instructions.
2. Remove the white handled thumb screws on the front of the accessory filter box kit located at the return air end of the appliance.
3. Let the top of the door fall towards you then push down towards the floor.
4. Remove the air filter. The air filter is a disposable filter. **DO NOT** attempt to clean the filter and reuse it.
5. Check the size of the air filter that was removed to make sure it is replaced with a filter that is the same size.
6. Clean any access dirt or debris around the front area where the air filter is located. Be careful not to use any small vacuum cleaner parts or any small brushes to clean inside the filter box, around the filter track. These parts or brushes can fall off or drop into the return duct causing a restriction of the return air flow.
7. Slide the air filter into the filter rack, push the door closed and tighten the thumb screw.
8. Follow the **“Turn On / Start the Appliance”** in the Startup and Shutdown Instructions section of these instructions.

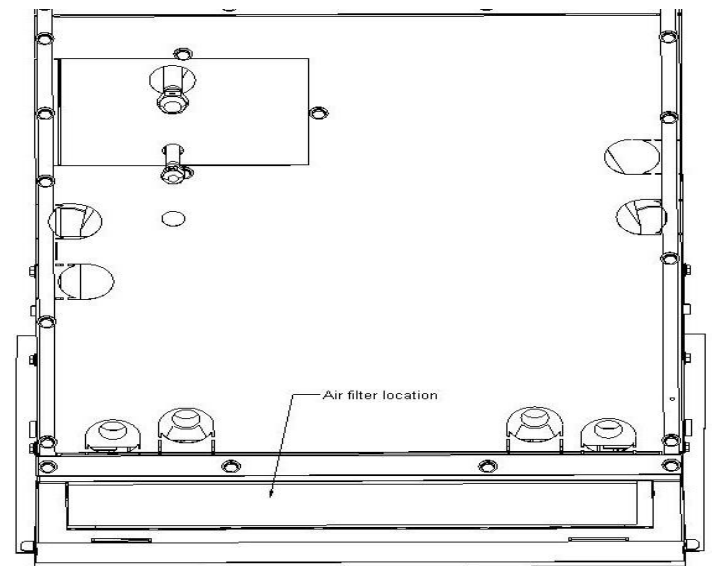
**NOTE:** Make sure the flow arrows on the air filter are pointing towards the coil.

Accessory filter box kit can be used on the return air end of the air handler when configured in the downflow position in place of a wall, door or ceiling mounted return filter grille.

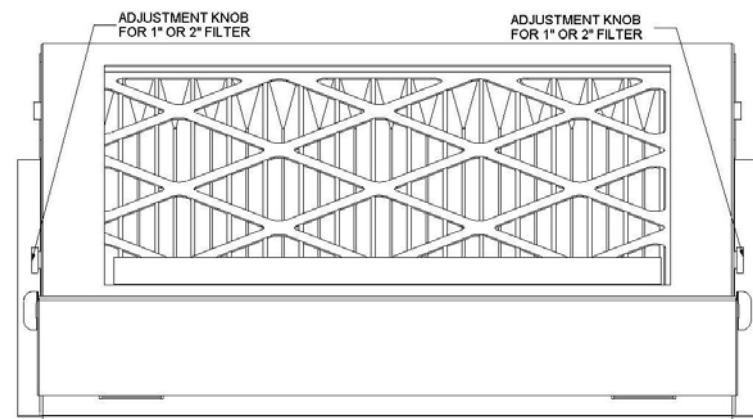


**Figure 4: Accessory Air Filter Box**

**NOTE:** Make sure the flow arrow on the air filter is pointing towards the coil.



**Figure 5: Accessory Air Filter Box – Air Filter Location**



**Figure 6: Accessory Air Filter Box – 1” or 2” Air Filter Adjustment knob. A knob is on both sides.**

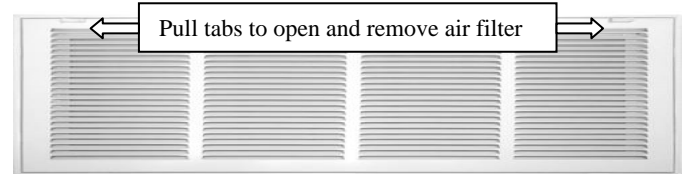
### Downflow / Horizontal Air Filter Replacement

Appliances that are installed in a downflow or horizontal position generally have the filters in filter grilles located in the ceiling or the wall next to the ceiling. Follow these easy steps to replace the air filters.

1. Follow the procedure “**To Turn Off the Appliance**” in the Startup and Shutdown Instructions section of these instructions.
2. Remove the white handled thumb screw on the front of the filter grille or pull down on the latches on each side of the grille door to release the door from the grille assembly.
9. Let the grille door fall towards you, then, just let it hang.
10. Remove the air filter. If the air filter is a disposable filter DO NOT attempt to clean the filter and reuse it.
11. Check the size of the air filter that was removed to make sure it is replaced with a filter that is the same size.
12. Clean any dust or debris from both sides for the louvers and around the area where the filter is placed before the new air filter are installed.

13. Place the new air filter back into the grille assembly, push the grille door closed and tighten the thumb screw or push the latches in on each side of the door until the door is securely fastened to the grille assembly.
14. Follow the “**Turn On / Start the Appliance**” in the Startup and Shutdown Instructions section of these instructions.

NOTE: Make sure the flow arrows on the air filter are pointing away from the grille door.



**Figure 7: Downflow / Horizontal Air Filter Location – Wall or Ceiling**

# SERVICE AND MAINTENANCE MANUAL

## SECTION I: SAFETY

**THE HOME OWNERS AND / OR APPLIANCE USERS MUST STOP HERE!**

This section has been designed to assist a **qualified service agency** in performing service and maintenance on this appliance.

**The homeowners and/or the appliance user must never attempt** to perform any service or maintenance on the appliance especially when it involves the removal or adjustment of any parts and/or components.

### ▲ WARNING

The manufacturer or distributor will not be responsible for any repairs due to removal of parts or improper parts changes, improper maintenance, improper adjustments or improper modifications to this air handler that were performed by the homeowner and/or the appliance user.

The manufacturer will not be responsible if the homeowner and/or appliance user use this section of the instructions in an attempt to perform maintenance or repairs to the furnace.

This practice is very dangerous and may result in a fire causing property damage, personal injury, loss of life and/or will void the appliance warranty.

**The following safety rules must be followed when servicing this furnace.**



This is a safety alert symbol. When you see this symbol on labels or in manuals; be alert to the potential for personal injury.

Understand and pay particular attention to the signal words **DANGER, WARNING, or CAUTION.**

**DANGER:** indicates an **imminently** hazardous situation, which if not avoided, **will result in death or serious injury.**

**WARNING:** indicates a **potentially** hazardous situation, which if not avoided, **could result in death or serious injury.**

**CAUTION:** indicated a **potentially** hazardous situation, which if not avoided, **may result in minor or moderate injury.** It is also used to alert against unsafe practices and hazards involving property damage.

### ▲ WARNING

Improper adjustment, service or maintenance may create a condition where the operation of the product could cause personal injury or property damage.

Refer to this manual for assistance or for additional information consult the Technical Support Group.

### ▲ CAUTION

This product must be serviced and maintained as specified in these instructions and/or to any applicable local, state, and national codes including, but not limited to building, electrical, and mechanical codes.

### ▲ WARNING

#### FIRE OR ELECTRICAL HAZARD

Failure to follow the safety warnings exactly could result in serious injury, death, or property damage.

A fire or electrical hazard may result causing property damage, personal injury or loss of life.

#### SAFETY REQUIREMENTS

1. The air handlers with electric heaters may have a dual electrical supply circuit. Make sure you check each electrical circuit with a meter to be sure the power has been disconnected.
2. Insulating materials may be combustible. The air handler must be kept free and clear of insulating materials.
3. Follow the instructions exactly as shown in Startup and Shutdown Section in this manual to properly Startup or Shutdown this appliance.
4. Make sure all moving parts have come to a complete stop before attempting to perform any work once the appliance door has been removed. Moving parts can cause serious injury if clothing or body parts get caught in the moving part.

### ▲ WARNING

#### ELECTRICAL SHOCK, FIRE HAZARD

**Failure to follow the safety warnings exactly or improper servicing could result in dangerous operation, serious injury, property damage, and/or death.**

- Before servicing, disconnect all electrical power to the appliance. Make sure you disconnect both power supplies if the appliance has a dual power supply circuit. Dual circuits may be used on the 15kW and 20kW models.
- When servicing controls, label all wires prior to disconnecting to aid in proper reconnection of wires.
- Verify proper operation after servicing by turning the thermostat above the room temperature for a brief period of time to ensure proper appliance operation

## WARNING

### FIRE HAZARD

#### NEVER PLACE A JUMPER BETWEEN "R" & "W"

Placing jumper wire between the RED and WHITE thermostat wires at the air handler in order to override the thermostat and energize the heater elements is an extremely dangerous practice that can result in damage to the thermostat, dangerous operation, serious injury, property damage and/or death.

## SECTION II: AIR HANDLER MAINTENANCE

The interior sections of the air handler must be cleaned and adjusted by a qualified service contractor once a year or before the start of each heating or cooling season. The following items must be checked:

1. The blower wheel and motor for excessive dirt.
2. The electric heaters for wear, damage or corrosion.
3. The electrical components for excessive dust, dirt, wear, or deterioration.
4. The supply air duct system for excessive dust, dirt or debris
5. The return air duct system for excessive dust, dirt or debris
6. All electrical wiring for wear, insulation cracks and/or damage.
7. Check the air conditioning evaporator coil for dust, debris or damage.
8. Check the evaporator coil drain pan for proper drainage to prevent water backup into the unit.
9. The air handler casing and all interior sheet metal panels or dividers.

### Air Handler Cleaning Procedure

1. Follow the instructions exactly as shown in Startup and Shutdown Section in this manual to properly shutdown this appliance.
2. Remove the upper access door on the front of the air handler.
3. Remove the lower access door on the front of the evaporator coil compartment.
4. ECM or X-13 Motors - Unplug the wire harnesses from the blower motor.  
PSC Motor – Unplug the wires from the 6 pin plug at the bottom of the control box.
5. Remove the two screws on the left and right side and the center screw on the bracket in front of the blower mounting plate and slide the blower out. Refer to Figure 8.
6. Place a piece of cardboard on top of the evaporator coil to prevent dirt or debris from falling onto the coil. Use a vacuum cleaner and a small brush to remove any dirt and debris from the blower and evaporator coil compartments.

7. Check the evaporator condensate drain pan for any debris and ensure the pan is properly draining by pouring water into the drain to check it.
8. Remove any excess water that may have spilled from checking the evaporator condensate drain.
9. Check in the area above the blower compartment where the heater elements are located and remove any dust, dirt or debris from around the heater elements. Be careful not to damage the heater elements with the vacuum hose or the brush.

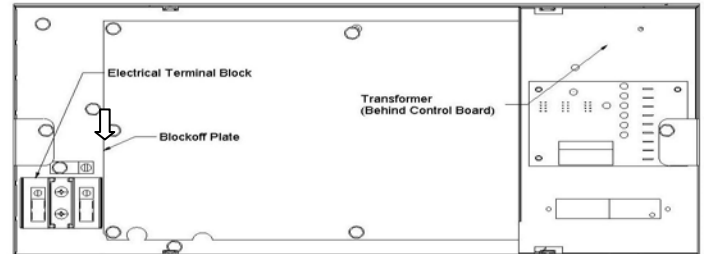


Figure 8: No Electric Heat Control Box

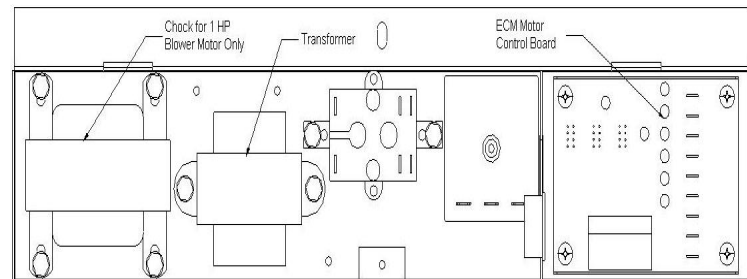


Figure 9: Hydronic Heat Control Box – No Pump

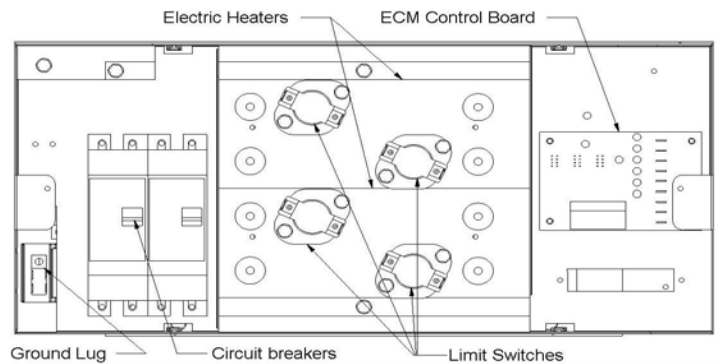


Figure 10: Electric Heat Control Box

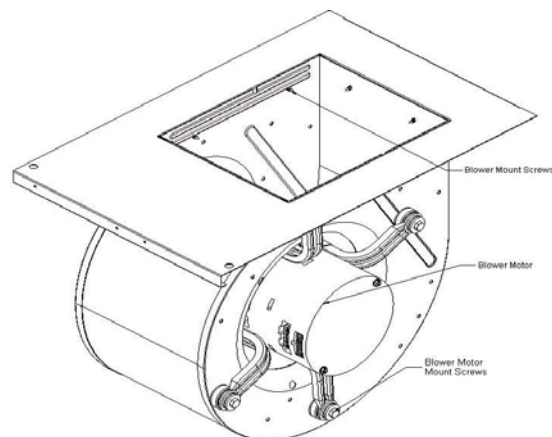


Figure 11: Blower Assembly and Mounting Screw Location

10. Check the blower wheel for dust and debris. Use the brush and the vacuum cleaner to remove any dust or debris from the wheel. Be careful not to move or accidentally remove the blower wheel balance weight located on the wheel blade. If it is moved or removed it will cause the blower wheel to vibrate. If the wheel is vibrating, you must replace it.
11. Check the blower motor for dust and debris. Be sure to clean the openings on the motor housing as these openings are used to cool the motor. If the dust, dirt or debris has not been removed from these openings it will cause the motor to run hotter than normal and will shorten the life of the motor.
12. Check and clean with the brush and vacuum cleaner any dust in the supply and return ducts as far as you can reach. If these ducts look like they have an excessive amount of dust, dirt or debris you should recommend to the home owner or user to call a professional to properly clean the duct system.
13. Check and clean any dust, dirt, or debris from all of the controls and all of the surfaces in the control box. If dust or dirt is left on the components they will operate at a much hotter temperature causing premature component failure.
14. Reinstall the blower assembly and secure the assembly to the casing by using the screws that was removed in step 5.
15. Reinstall the lower access door on the front of the evaporator coil compartment.
16. Reinstall the upper access door on the air handler.
17. Follow the instructions exactly as shown in Startup and Shutdown Section in this manual to properly startup this appliance.

### SECTION III: AIR HANDLER CONTROLS

#### Electric Heat Models

This section discusses the air handler controls and how they operate. Refer to Figure 9 for component locations.

1. **The Limit Controls** – Each electric heater element has a limit control directly in front of it to sense overheating of the element and open if the temperature gets above the set point of the limit control.
2. **The Heater Relays** – The electric heater relays simply turn the heater elements on and off. The relays are controlled by the thermostat. On a call for heat 24 VAC is sent to the relay(s) 24 VAC coil energizing the relay. When the call for heat has been satisfied the 24 VAC is removed from the relays 24 VAC coil de-energizing the relay(s).
3. **Cooling Time Delay Relay (TDR)** – The cooling sequencer relay is used only on models with a PSC motor. When the thermostat calls for cooling or the fan switch on the thermostat is moved from the “AUTO” to the “ON” position, 24 VAC is placed on the “G” terminal from the thermostat to the 24 VAC coil on the sequencer relay. The relay controls the blower on time delay and is not adjustable. The sequencer setting is approximately 30 - 45 seconds on and 1 - 20 off.
4. **Circuit breakers** – The circuit breakers are designed as over-current protection for the air handler internal electrical components. Field wiring must be protected by

field supplied circuit breakers or fuses sized to protect the wire connected to the air handler circuit breakers.

5. **Transformer** – The transformer is used to step down voltage from 240 VAC to 24 VAC. The transformer provides the required 24 VAC for the system control circuit.
6. **Blower Motor Isolation Relay** - This relay is used to load the TDR when using a PSC or X-13 motor or for isolation between the high and low speeds of a motor. The wiring has been designed so that the normally closed contacts are used for heating and the normally open contacts are used for cooling. The relay coil is energized after the thermostat has a call from the “G” terminal starting the time delay cycle on the sequencer relay. Once the time delay relay has reached the delay setting the relay contacts close energizing the isolation relay coil. The normally closed contacts on the isolation relay open and the normally open contacts close, energizing the motor on the selected cooling speed.

**ECM Motor Isolation Relay** - This relay is not used on the ECM motor which has programmable heating and cooling blower time delays along with climate profile time delays. See climate profile section for more information.

#### Hydronic Heat Models

This section discusses the air handler controls and how they operate. Refer to Figure 10 for component locations.

1. **Transformer** – The transformer is used to step down voltage from 240 VAC to 24 VAC. The transformer provides the required 24 VAC for the system control circuit.
2. **Pump Relay** – This relay is not used on all hydronic models. This relay is a single pole single throw relay that energizes the water pump on a call for heat. The 24 VAC coil is connected to the thermostat “W” terminal. The coil is energized on a call for heat closing the normally open terminals sending 120 VAC thru the relay contacts to the water pump motor. Once the call for heat has been satisfied, the 24 VAC is removed from the thermostat “W” terminal de-energizing the relay coil and opening the contacts to the water pump motor.
3. **PSC Blower Motor Isolation Relay** - This relay is a single pole double throw relay. Is required for isolation between the high and low speeds of a motor. The wiring has been designed so that the normally closed contacts are used for heating and the normally open contacts are used for cooling. The relay coil is energized after the thermostat has a call from the “G” terminal. The normally closed contacts on the isolation relay open and the normally open contacts close, energizing the motor on the selected cooling speed.
4. **ECM Motor Isolation Relay** - This relay is not used on the ECM motor has programmable heating and cooling blower time delays along with climate profile time delays. See climate profile section for more information.

### SECTION IV: SEQUENCE OF OPERATION

#### Continuous Blower – Electric Heat Models

The thermostat has a manual fan switch that can be moved to the “On” position or it can be programmed for **continuous fan**

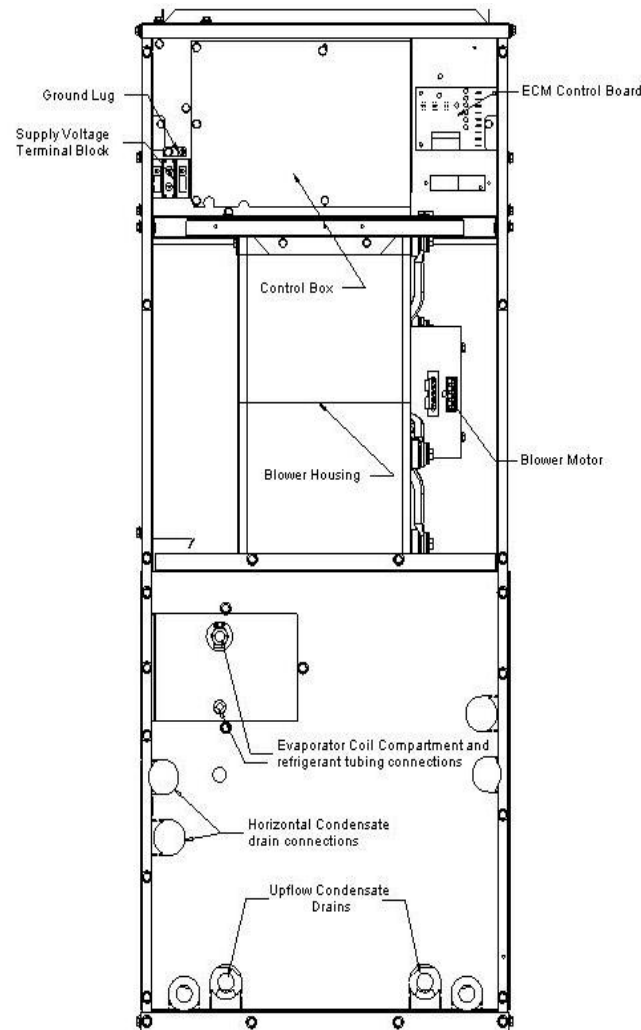
operation. This setting causes the thermostat to complete the circuit between “R” and “G” terminals causing the sequencer relay to start the time delay cycle. Once the time delay relay has completed the on-delay cycle the contacts will close sending voltage to the isolation relay coil. The isolation relay will close the normally open contacts (Terminals #2 and #4) sending voltage to selected indoor blower motor speed tap connected to terminal #4. The normally closed contacts (Terminals #5 and #6) will open.

The indoor blower will operate continuously until the fan switch on the thermostat has been switched from on to auto.

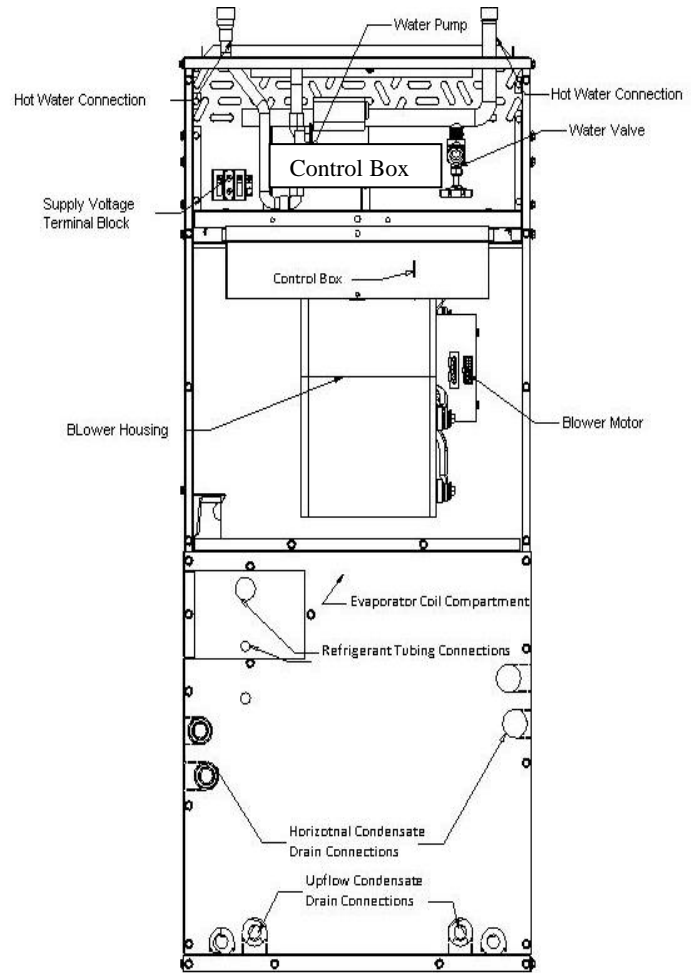
**Continuous Blower – Hydronic Heat Models**

The thermostat has a manual fan switch that can be moved to the “On” position or it can be programmed for **continuous** fan operation. This setting causes the thermostat to complete the circuit between “R” and “G” terminals sending 24 VAC to the isolation relay coil. The isolation relay will close the normally open contacts (Terminals #2 and #4) sending voltage to selected indoor blower motor speed tap connected to terminal #4. The normally closed contacts (Terminals #5 and #6) will open.

The indoor blower will operate continuously until the fan switch on the thermostat has been switched from on to auto.



**Figure 12: Component Locations – Electric Heat Models**



**Figure 13: Component Locations – Hydronic Heat Models**

**Intermittent Blower – Cooling Electric Heat Models**

The thermostat has a manual fan switch that can be moved to the “Auto” position or it can be programmed for **auto** fan operation. When the thermostat calls for cooling, a circuit is completed between the “R”, “Y” and “G” Terminals. The indoor fan motor is energized from the “G” terminal on the thermostat causing the time delay relay to start the on-time delay. The time delay relay contacts will close the circuit to the isolation relay coil after the on- delay is complete. The isolation relay normally open contacts (Terminals #2 and #4) will close and the motor will operate on the selected speed tap that has been placed on terminal #4.

When the thermostat is satisfied the circuit between “R”, “Y” and “G” will open. The time delay relay will open the circuit to the isolation relay and the PSC blower motor will turn off. The X-13 blower motor will have a 13 second off-delay. The blower is now in the standby mode waiting for the next cooling cycle

**Hydronic Heat Models**

The thermostat has a manual fan switch that can be moved to the “Auto” position or it can be programmed for **auto** fan operation. When the thermostat calls for cooling, a circuit is completed between the “R”, “Y” and “G” terminals sending 24 VAC to the isolation relay coil. The isolation relay

normally open contacts (Terminals #2 and #4) will close and the motor will operate on the selected speed tap that has been placed on terminal #4.

When the thermostat is satisfied the circuit between “R”, “Y” and “G” will open. The circuit to the isolation relay will open and the PSC or X-13 blower motor will turn off. The blower is now in the standby mode waiting for the next cooling cycle

## **The Heating Cycle**

### **Electric Heat Models**

When the thermostat is in the HEAT mode and the fan switch on the thermostat is set to AUTO. The call for heat closes the thermostat circuit between the “R” and “W” terminals. 24 VAC is sent from the “W” terminal on the thermostat, through the white thermostat wire, to the white pigtail wire on the air handler, to the 24 VAC coil on the first heater relay. This signal energizes the heater relay, closing the contacts and sending 240 vac to the heaters. The blower PSC motor low speed wire is also connected to the heater terminal on the first heater relay so the blower is energized at the same time as the heater. The blower will continue to operate until the thermostat is satisfied. When the call for heat has been removed the “W” terminal is de-energized and the heater relay opens turning off the heater and the PSC blower motor.

The X-13 blower motor is connected to the normally closed contacts of the isolation relay. The 24 VAC signal from the “W” terminal on the thermostat will energize the motor at the same time as the heater relay and will de-energize the motor at the same time as the heater relay.

The furnace is now in standby mode waiting for the next heating cycle.

Some models have a brown pigtail wire that is connected to the 24 VAC coil on the second heater relay. This pigtail wire is to be used for second stage heat. It is connected to the thermostat “W2” terminal. You must have a thermostat that has the second stage heating feature “W2” to use this feature. The second stage heat cycle is enabled when the room temperature typically falls more than 3 degrees below the thermostat set point. The thermostat energizes the second heater to aid in heating the room back to the thermostat set point. Once the room is within 1 degree of the thermostat set point the second stage heater is de-energized until the thermostat calls for second stage heat “W2” again.

### **Hydronic Heat Models**

When the thermostat is in the HEAT mode and the fan switch on the thermostat is set to AUTO. The call for heat closes the thermostat circuit between the “R” and “W” terminals. 24 VAC is sent from the “W” terminal on the thermostat, through the white thermostat wire to the white pigtail wire on the air handler, to the 24 VAC coil on the water pump relay. This will energize the water pump and start circulation of hot water through the water coil.

At the same time 24 VAC is sent to the heat relay coil energizing the relay and closing the normally open contacts on the heat relay sending 120 VAC through the normally closed contacts on the isolation relay to blower PSC motor low speed wire. The blower will continue to operate until the thermostat is satisfied. When the call for heat has been removed the “W”

terminal is de-energized and the heat relay and the pump relay open turning off the water pump and the PSC blower motor. The X-13 blower motor is connected to the normally closed contacts of the isolation relay. The 24 VAC signal from the “W” terminal on the thermostat will energize the motor at the same time as the water pump relay and will de-energize the motor at the same time as the water pump relay.

The furnace is now in standby mode waiting for the next heating cycle.

## **The Cooling Cycle**

### **Electric Heat Models**

#### **When the thermostat calls for cooling**

The thermostat closes the circuit between the “R”, “Y” and “G” terminals. 24 VAC is sent from the “Y” terminal through the yellow thermostat wire to the 24 VAC coil terminal on the condenser contactor; energizing the contactor and starting the compressor and outdoor fan motor. At the same time the “G” terminal is sending 24 VAC through the green pigtail wire to the indoor blower time delay sequencer. The time delay sequencer goes through a 30 - 45 second on-delay, and then closes the normally open contacts sending 24 VAC to terminal #1 on the isolation relay coil ( Coil between terminals #1 and #3). The isolation relay coil is energized closing the normally open contacts (Terminals #2 and #4) and opening the normally closed contacts (Terminals #5 and #6) sending 24 VAC to the selected X-13 motor speed tap wire connected to isolation relay terminal #4 or for PSC motors; sending 240 VAC to the selected speed tap wire connected to isolation relay terminal #4.

When the thermostat call for cooling has been satisfied the thermostat opens the circuit between the “R”, “Y” and “G” terminals. The 24 VAC signal is removed from the thermostat “Y” terminal de-energizing condenser contactor and outdoor fan motor. At the same time the “G” terminal 24 VAC is removed from the green pigtail wire de-energizing the time delay sequencer. The sequencer will go through a 1-20 second off delay.

The cooling cycle is complete, and the cooling unit is ready for the start of the next cooling cycle.

### **The Motor Isolation Relay**

This relay is used in conjunction with the motors to prevent the possibility of the motors being energized on two speed taps at the same time. This condition would burn out the motor windings.

PSC motor has a black wire is connected from the circuit breaker to the supply side of the normally open terminals on the relay. The blower motor high speed tap wire is connected to the load side (Terminal #4) normally open terminal on relay.

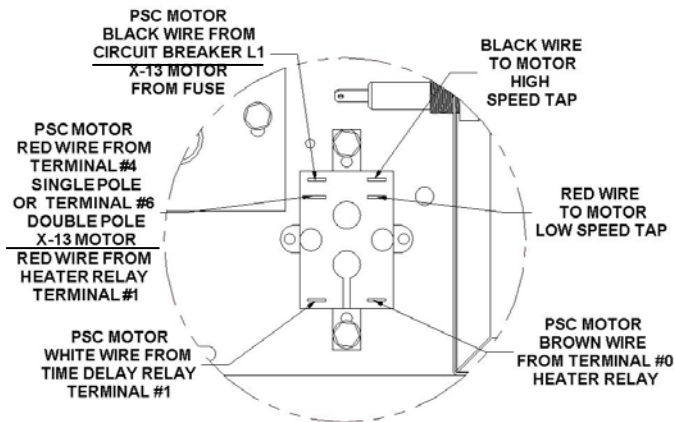
X-13 motor has a black wire that is connected from the “W” terminal #1 on the heat relay to the supply side (Terminal #2) of the normally open terminals on the isolation relay. The blower motor high speed tap wire is connected to the load side (Terminal #4) normally open terminal on relay.

PSC motor has a red wire is connected from the load side of the heat relay (Terminal # 4 or 6) to the normally closed terminal (Terminal #5) on the isolation relay. The load side

(Terminal #6) of the normally closed terminal is connected to the low speed tap blower motor.

X-13 motor has a red wire is connected from the 24 VAC coil of the heat relay (Terminal #0) to the normally closed terminal (Terminal #5) on the isolation relay. The load side (Terminal #6) of the normally closed terminal is connected to the low speed tap blower motor.

ECM motors are connected and controlled by a ECM control board. The thermostat wires are connected to the thermostat terminals on the ECM control board. Isolation relay is not used with a ECM motor.



**Figure 14: Motor Speed Tap Isolation Relay – X-13 and PSC Motors**

**WARNING**

For personal safety be sure to turn the electrical power “OFF” at the main entrance (Circuit Breaker Box) and at the control box circuit breakers before attempting any service or maintenance operations. Home owners should never attempt to perform any maintenance which requires opening the air handler control box door.

## SECTION V: TROUBLE SHOOTING

The following checks should be made before trouble shooting the air handler controls for a no heat issue.

1. Check all of the circuit breakers. Make sure they are turned to the “ON” position and have not tripped.
2. Check all fuses, especially any supply line fuses that were installed during installation. If the fuse is blown, check the wiring with an OHM meter for a short to ground. If shorted, repair the short, and then replace the fuse.
3. Check any electrical switches that are external to the furnace to make sure they are turned on.
4. Check all wiring connections, especially on any of the components, to ensure they are securely fastened.

### Electric Heat Models

If you have electric heaters and there is 240 volts coming out of the control box circuit breakers and you have 24 volts between to the “R” wire and ground, then continue on through the rest of the checks.

### X-13 Motor Check – Electric Heat Models

If the motor is not running, check for 240 volts and 24 volts at the motor terminals. If the 240 volts and 24 volts is present at the motor terminals but the motor is not operating, then replace the motor. Refer to Figure 14 and Table 1 for terminal locations and definitions.

If 240 volts is not present check the connections to the circuit breaker or check for an open breaker.

### Hydronic Heat Models

If you have hydronic heat and there is 120 volts to the transformer and you have 24 volts between to the “R” wire and ground, then continue on through the rest of the checks.

### X-13 Motor Check – Hydronic Heat Models

If the motor is not running, check for 120 volts and 24 volts at the motor terminals. If the 120 volts and 24 volts is present at the motor terminals but the motor is not operating, then replace the motor. Refer to Figure 14 and Table 1 for terminal locations and definitions.

If 120 volts is not present check the connections to the circuit breaker or check for an open breaker.

### Heating Mode

If 24 volts is not present check the thermostat “W” wire. If 24 volts is present, check the Heat Relay Terminal #4. If 24 volts is present, check isolation relay terminal #6, if 24 volts is present replace the wire going to the motor. If 24 volts is not present at the heat relay or the isolation relay, then, change that relay.

### Cooling Mode

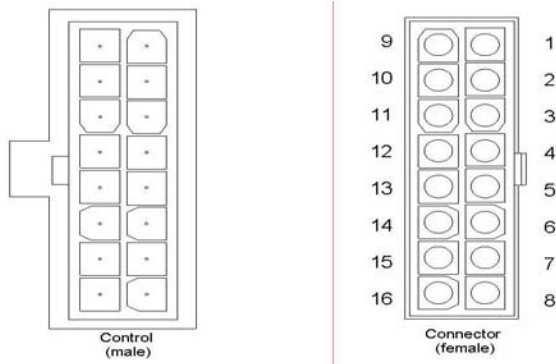
If 24 volts is not present check the thermostat “G” wire. If 24 volts is present, check the sequencer Relay Terminal #4. If 24 volts is present, check isolation relay terminal #4, if 24 volts is present replace the wire going to the motor. If 24 volts is not present at the sequencer relay change the relay. If 24 volts is not present at the isolation relay coil but is not present on terminal #6 change the isolation relay.

### ECM Motor Check – Electric Heat Models

If the motor is not running, check for 240 volts is present at the motor terminals and 24 volts is present at the control board. If the 240 volts and 24 volts is present at the motor and board but the motor is not operating, then check the control board thermostat terminals to determine if 24 volts is present at “R” and “W”.

### ECM Motor Check – Hydronic Heat Models

If the motor is not running, check for 120 volts is present at the motor terminals and 24 volts is present at the control board. If the 120 volts and 24 volts is present at the motor and board but the motor is not operating, then check the control board thermostat terminals to determine if 24 volts is present at “R” and “W”.



**Figure 15: ECM Motor Control Pin out**

Pin Number

- 1 Common C1
- 2 W/W1
- 3 Common C2
- 4 Delay Tap Select
- 5 Cool Tap Select
- 6 Y1
- 7 Adjust Tap Select
- 8 Output –
- 9 Reversing Valve (Heat Pump Only)
- 10 Humidistat (BK)
- 11 Heat Tap Select
- 12 24 VAC (R)
- 13 2<sup>nd</sup> Stage Heat (EM/W2)
- 14 2<sup>nd</sup> Stage Cool (Y/Y2)
- 15 Fan (G)
- 16 Output +

NOTE: Volt meter will not read between pins 4, 5, 7, 11 and 1 or 3 because these signals are not full wave signals.

To verify ECM board is functioning properly in the heating mode check for 24 volts between pins 1 and 2.

To verify ECM board is functioning properly in the cooling mode check for 24 volts between pins 1 and 6 also 1 and 15.

### PSC Motor Check – Electric Heat Models

If the motor is not running, check for 240 volts at the motor speed tap terminal. If the 240 volts is present at the motor speed tap terminal but the motor is not operating, then replace the motor.

#### Heating Mode

If 240 volts is present at the motor check between the Heat Relay Terminal #4 and L2. If 240 volts is present, check isolation relay between terminal #6 and L2, if 240 volts is present replace the motor. If 240 volts is not present between the heat relay and L2 change the relay. If 240 volts is not present between the isolation relay and L2 change the relay.

#### Cooling Mode

If 24 VAC is not present check the thermostat “G” wire. If 24 VAC is present, check the sequencer Relay Terminal #4 for 240 volts. If 240 volts is present, check isolation relay terminal #4, if 240 volts is present replace the motor. If 240 volts is not present between Terminal #4 and L2 on the sequencer relay, check for 24 volts at the coil. If 24 volts is present at the coil change the relay. If 240 volts is not present at the isolation relay, check for 24 volts at the coil. If 24 volts is present at the coil but 240 volts is not present between terminal #4 and L2 change the isolation relay.

### PSC Motor Check – Hydronic Heat Models

If the motor is not running, check for 120 volts at the motor speed tap terminal. If the 120 volts is present at the motor speed tap terminal but the motor is not operating, then replace the motor.

#### Heating Mode

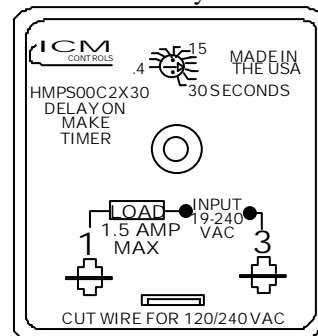
If 120 volts is present at the motor check between the Heat Relay Terminal #4 and Neutral. If 120 volts is present, check isolation relay between terminal #6 and neutral, if 120 volts is present, replace the motor. If 120 volts is not present between the heat relay and neutral change the relay. If 120 volts is not present between the isolation relay and neutral change the relay.

#### Cooling Mode

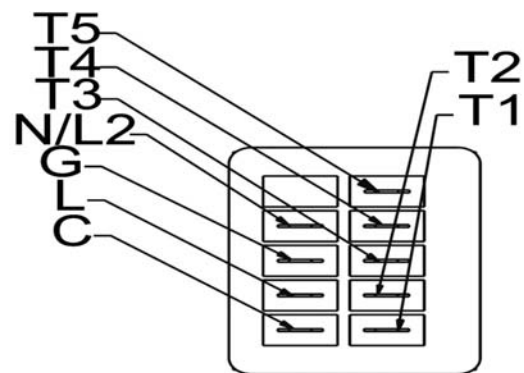
If 24 VAC is not present, check the thermostat “G” wire. If 24 VAC is present, check the sequencer Relay Terminal #4 for 120 volts. If 120 volts is present, check isolation relay terminal #4, if 120 volts is present, replace the motor.

If 120 volts is not present between Terminal #4 and neutral on the sequencer relay, check for 24 volts at the coil. If 24 volts is present at the coil change the relay.

If 120 volts is not present between terminal #4 on the isolation relay and neutral, but is present on terminal #2 and neutral, check for 24 volts at the coil. If 24 volts is present at the coil, change the isolation relay.



**Figure 16: Adjustable Time Delay Relay (TDR) Terminals**



**Figure 17: X-13 Motor Terminals**

### WARNING

To avoid personal injury or property damage, make certain that the motor leads cannot come into contact with non-insulated metal components of the unit.

Terminal	Connection
C	Speed Tap Common - 24 VAC Common
L	Supply Voltage - 240 Vac Line 1
G	Ground Connection
N/L2	Supply Voltage - 240 Vac Line 2
1	Low Speed Tap - 24 VAC Input
2	Medium-Low Speed Tap - 24 VAC Input
3	Medium Speed Tap - 24 VAC Input
4	Medium-High Speed Tap - 24 VAC Input
5	High Speed Tap - 24 VAC Input

**Table 1: X-13 Motor Terminal Connections**

**Heater Element Is Not On**

Check for 240 VAC between each of the heater elements. If 240 VAC is present, check the current draw on each heater. If there is almost no current draw check the limit for that heater. If the limit is good but there still is no current flow then, check to see if the heater is defective.

The heater amps are as follows:

- 5 kW Heater = 20.8 amps
- 10 kW Heater = 41.6 amps

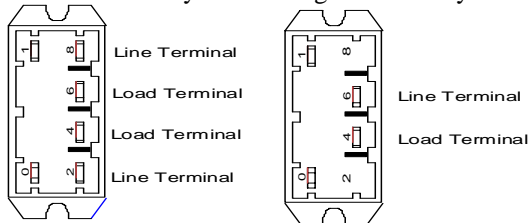
The heater design is as follows:

- The 5 kW model has one 5 kW heater element.
- The 10 kW model has one heater with two 5 kW elements
- The 15 kW model has one heater with two 5 kW elements (top heater) and one heater with one 5 kW element (bottom heater).
- The 20 kW model has one heater with two 5 kW elements (top heater) and one heater with two 5 kW elements (bottom heater).

If 240 VAC is not present at the heater element but there is 240 VAC present between the line terminal of the heater relay and L2 circuit breaker but not across the heater, then, check the limit control for an open limit and replace the open limit control.

If 240 VAC is not present at the heater element or between the load terminal of the heater relay and the L2 circuit breaker, but is present between the line terminal of the heater relay and L2 circuit breaker; then, replace the heater relay.

DP - Double Pole Relay    SP - Single Pole Relay



**Figure 18: Heater Relay Terminal Designations**

HP	ECM	X-13	PSC
1/3	0.78	0.72	2.00
1/2	2.00	1.66	3.00
3/4	2.50	2.09	3.60
1.0	3.75	5.72	

**Table 2: 208 / 240 Volt Blower Motor Tested FLA**

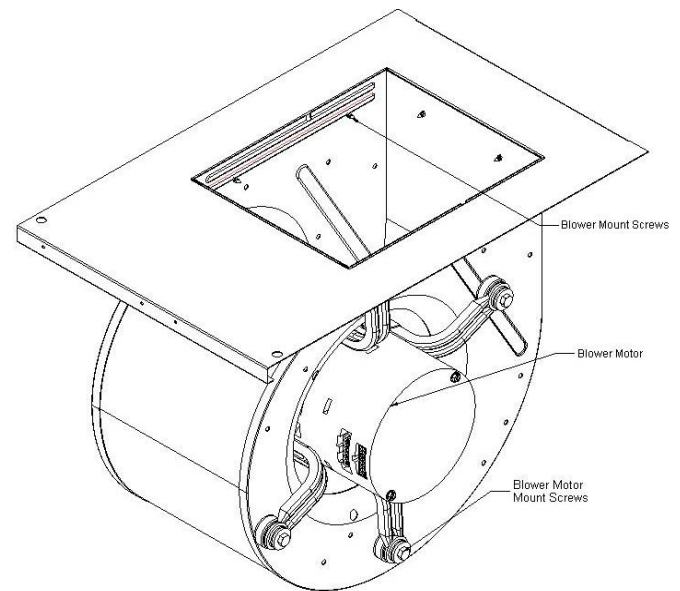
HP	ECM	X-13	PSC
1/3	1.80	2.72	4.40
1/2	2.31	2.72	7.70
3/4	6.31	5.71	11.00
1.0	8.48	8.48	

**Table 3: 120 Volt Blower Motor Tested FLA**

MORTEX PRODUCTS INC

**Replacing the Blower**

- Follow the instructions exactly as shown in Startup and Shutdown Section in this manual to properly shutdown this appliance.
- Remove the upper access door on the front of the air handler.
- Remove the lower access door on the front of the evaporator coil compartment.
- ECM or X-13 Motors - Unplug the wire harnesses from the blower motor.  
PSC Motor – Unplug the wires from the 6 pin plug at the bottom of the control box.
- Remove the two screws on the left and right side and the center screw on the bracket in front of the blower mounting plate and slide the blower out.
- Reinstall the blower assembly and secure the assembly to the casing by using the bracket and screws that were removed in step 5.
- Reinstall the lower access door on the front of the evaporator coil compartment.
- Reinstall the upper access door on the air handler.
- Follow the instructions exactly as shown in Startup and Shutdown Section in this manual to properly startup this appliance.
- Set the thermostat above the room temperature so the unit will operate and you can observe the appliance startup to ensure the appliance is operating correctly.
- After proper operation has been observed and documented, set the thermostat to the desired temperature.



**Figure 19: Blower Mounting Plate Screw Locations**

**WARNING**

To avoid personal injury take precautions not come into contact with non-insulated electrical components.

Avoid wearing loose clothing or any items that can come in contact with moving parts, such as the blower wheel. This can cause serious personal injury

## SECTION VI: BLOWER PERFORMANCE

Model Number	Nominal Tons	Motor HP	Volts 1 Ph. 50/60 Hz.	Motor Code	Blower Wheel	Jumper	CFM @ 0.10"	CFM @ 0.20"	CFM @ 0.30"	CFM @ 0.40"	CFM @ 0.50"
MSVE18,24 Electric	1.5 & 2.0	0.33	240	VA	9 X 6	A	837	837	824	817	806
						B	744	733	721	717	713
						C	705	697	689	681	677
						D	634	620	615	611	602
MSVE18,24 Hydronic	1.5 & 2.0	0.33	120	VG	10X7	A	884	884	884	880	880
						B	799	792	789	789	789
						C	691	691	691	691	690
						D	589	589	589	589	584
MSVE25,30,36 Electric	1.5 Thru 3.0	0.50	240	VB	10 X 7	A	1422	1421	1421	1416	1416
						B	1215	1214	1214	1214	1208
						C	898	989	989	982	969
						D	865	865	865	866	858
MSVE25,30,36 Hydronic	1.5 Thru 3.0	0.50	120	VH	10 X 7	A	1294	1255	1200	1137	1058
						B	1131	1104	1075	1082	1023
						C	974	942	909	853	831
						D	808	769	736	702	657
MSVE37,42,48,60 Electric	3.0 Thru 5.0	0.75	240	VC	12 X 9	A	1957	1919	1900	1871	1847
						B	1576	1565	1547	1517	1487
						C	1495	1482	1451	1432	1409
						D	1411	1385	1372	1338	1311
MSVE37,42,48,60 Hydronic	3.0 Thru 5.0	1.00	120	VI	12 X 9	A	2001	1994	1994	1987	1972
						B	1820	1820	1820	1804	1796
						C	1587	1599	1604	1604	1604
						D	1385	1385	1385	1385	1385
MSVE72 Electric	6.0	1.00	240	VU	12 X 10	A	2393	2393	2393	2393	2388
						B	2227	2227	2221	2221	2221
						C	2012	2012	2005	2005	2005
						D	1795	1795	1795	1795	1795
MSVE72 Hydronic	6.0	1.00	120	VW	12 X 10	A	2132	2119	2091	2077	2063
						B	1921	1901	1901	1886	1886
						C	1724	1724	1724	1724	1707
						D	1508	1508	1508	1488	1488

**Table 4: MSVE Blower Performance Chart – CFM Data with a ECM 2.3 Motor -Without Air Filters**

Model Number	Nominal Tons	Motor HP	Volts 1 Ph. 50/60 Hz.	Motor Code	Blower Wheel	Jumper	AMPS @ 0.10"	AMPS @ 0.20"	AMPS @ 0.30"	AMPS @ 0.40"	AMPS @ 0.50"
MSVE18,24 Electric	1.5 & 2.0	0.33	240	VA	9 X 6	A	0.530	0.610	0.650	0.710	0.780
						B	0.430	0.470	0.490	0.520	0.560
						C	0.370	0.430	0.470	0.500	0.530
						D	0.310	0.350	0.380	0.420	0.450
MSVE18,24 Hydronic	1.5 & 2.0	0.33	120	VG	10X7	A	3.120	3.470	3.730	4.060	4.370
						B	2.440	2.710	2.950	3.240	3.620
						C	1.760	2.090	2.400	2.690	2.910
						D	1.270	1.530	1.810	2.090	2.310
MSVE25,30,36 Electric	1.5 Thru 3.0	0.50	240	VB	10 X 7	A	1.690	1.730	1.790	1.950	2.030
						B	1.020	1.110	1.190	1.270	1.390
						C	0.580	0.640	0.710	0.780	0.850
						D	0.440	0.510	0.570	0.640	0.690
MSVE25,30,36 Hydronic	1.5 Thru 3.0	0.50	120	VH	10 X 7	A	3.700	3.800	3.700	3.500	3.400
						B	2.700	2.800	3.000	3.100	3.200
						C	1.900	2.000	2.100	2.100	2.300
						D	1.200	1.300	1.500	1.600	1.700
MSVE37,42,48,60 Electric	3.0 Thru 5.0	0.75	240	VC	12 X 9	A	1.900	1.900	2.100	2.300	2.500
						B	1.100	1.200	1.400	1.500	1.600
						C	0.800	0.900	1.100	1.200	1.200
						D	0.900	1.000	1.200	1.300	1.400
MSVE37,42,48,60 Hydronic	3.0 Thru 5.0	1.00	120	VI	12 X 9	A	6.240	6.400	6.690	7.110	6.310
						B	4.970	5.130	5.320	5.510	5.650
						C	3.540	3.750	3.860	4.120	4.330
						D	2.580	2.720	2.850	3.070	3.290
MSVE72 Electric	6.0	1.00	240	VU	12 X 10	A	2.920	3.130	3.290	3.570	3.750
						B	2.280	2.390	2.620	2.780	2.960
						C	1.650	1.810	2.030	2.130	2.330
						D	1.210	1.310	1.510	1.610	1.730
MSVE72 Hydronic	6.0	1.00	120	VW	12 X 10	A	8.170	8.410	8.680	8.990	9.200
						B	5.760	6.100	6.410	6.640	7.070
						C	4.010	4.390	4.740	5.060	5.460
						D	2.690	2.910	3.150	3.410	3.670

**Table 5: MSVE Blower Performance Chart – Amp Data with a ECM 2.3 Motor -Without Air Filters**

Model Number	Nominal Tons	Motor HP	Volts 1 Ph. 50/60 Hz.	Motor Code	Blower Wheel	Motor Tap	CFM @ 0.10"	CFM @ 0.20"	CFM @ 0.30"	CFM @ 0.40"	CFM @ 0.50"
MSVT18,24 Electric	1.5 & 2.0	0.33	240	VD	9 X 6	1	795	783	726	709	691
						2	872	865	806	790	775
						3	1002	970	929	884	827
						4	1088	1048	998	938	872
						5	1114	1073	1018	960	888
MSVT18,24 Hydronic	1.5 & 2.0	0.33	120	VJ	9 X 6	1	693	666	657	618	598
						2	753	745	711	693	675
						3	785	753	745	720	702
						4	838	816	808	777	753
						5	874	860	846	816	769
MSVT25,30,36 Electric	1.5 Thru 3.0	0.50	240	VE	10 X 7	1	814	791	752	711	658
						2	846	828	799	768	711
						3	1059	1036	1007	982	957
						4	1152	1136	1104	1087	1053
						5	1247	1213	1192	1167	1136
MSVT25,30,36 Hydronic	1.5 Thru 3.0	0.50	120	VK	10 X 7	1	714	668	639	587	517
						2	874	845	806	782	732
						3	1082	1046	1015	983	951
						4	1156	1122	1094	1065	1028
						5	1313	1262	1226	1156	1077
MSVT37,42,48,60 Electric	3.0 Thru 5.0	0.75	240	VF	12 X 9	1	1339	1247	1198	1160	1107
						2	1467	1415	1394	1339	1294
						3	1556	1518	1478	1427	1385
						4	1661	1617	1590	1532	1493
						5	2070	2034	1997	1951	1897
MSVT37,42,48,60 Hydronic	3.0 Thru 5.0	1.00	120	VL	12 X 9	1	1479	1448	1416	1373	1341
						2	1558	1529	1499	1459	1438
						3	1641	1614	1596	1548	1510
						4	1783	1749	1723	1670	1625
						5	1935	1879	1764	1764	1694
MSVT72 Electric	6.0	1.00	240	VV	12 X 10	1	1910	1865	1826	1787	1787
						2	2088	2054	2019	1969	1932
						3	2240	2201	2162	2129	2088
						4	2370	2339	2290	2246	2208
						5	2504	2470	2441	2393	2351
MSVT72 Hydronic	6.0	1.00	120	VX	12 X 10	1	1637	1619	1584	1547	1510
						2	1795	1771	1730	1697	1663
						3	1887	1865	1842	1803	1754
						4	1990	1954	1903	1849	1787
						5	2040	1990	1925	1872	1810

**Table 6: MSVT Blower Performance Chart – CFM Data with a X-13 Motor -Without Air Filters**

Model Number	Nominal Tons	Motor HP	Volts 1 Ph. 50/60 Hz.	Motor Code	Blower Wheel	Motor Tap	AMPS @ 0.10"	AMPS @ 0.20"	AMPS @ 0.30"	AMPS @ 0.40"	AMPS @ 0.50"
MSVT18,24 Electric	1.5 & 2.0	0.33	240	VD	9 X 6	1	0.370	0.400	0.420	0.430	0.450
						2	0.440	0.470	0.480	0.490	0.520
						3	0.490	0.500	0.530	0.540	0.550
						4	0.510	0.530	0.550	0.580	0.590
						5	0.660	0.670	0.700	0.710	0.720
MSVT18,24 Hydronic	1.5 & 2.0	0.33	120	VJ	9 X 6	1	0.900	0.900	1.000	1.100	1.200
						2	1.100	1.200	1.200	1.200	1.300
						3	1.200	1.200	1.300	1.300	1.310
						4	1.400	1.400	1.500	1.510	1.600
						5	1.600	1.700	1.700	1.710	1.800
MSVT25,30,36 Electric	1.5 Thru 3.0	0.50	240	VE	10 X 7	1	0.650	0.670	0.700	0.720	0.750
						2	0.810	0.840	0.870	0.900	0.940
						3	1.120	1.150	1.180	1.220	1.210
						4	1.350	1.380	1.410	1.440	1.450
						5	1.590	1.610	1.620	1.630	1.660
MSVT25,30,36 Hydronic	1.5 Thru 3.0	0.50	120	VK	10 X 7	1	1.500	1.500	1.600	1.700	1.710
						2	2.300	2.400	2.400	2.410	2.410
						3	2.600	2.600	2.600	2.610	2.620
						4	2.600	2.600	2.610	2.620	2.630
						5	2.700	2.700	2.710	2.710	2.720
MSVT37,42,48,60 Electric	3.0 Thru 5.0	0.75	240	VF	12 X 9	1	0.640	0.640	0.690	0.730	0.770
						2	0.820	0.860	0.900	0.940	1.000
						3	0.960	1.000	1.050	1.090	1.140
						4	1.080	1.120	1.170	1.210	1.290
						5	2.000	2.050	2.090	2.140	2.250
MSVT37,42,48,60 Hydronic	3.0 Thru 5.0	1.00	120	VL	12 X 9	1	2.920	2.970	3.060	3.140	3.250
						2	3.440	3.480	3.590	3.660	3.740
						3	3.950	4.050	4.120	4.210	4.270
						4	5.050	5.120	5.180	5.240	5.270
						5	6.830	6.580	6.260	5.990	5.710
MSVT72 Electric	6.0	1.00	240	VV	12 X 10	1	2.810	2.910	3.000	3.140	3.260
						2	3.680	3.800	3.940	4.030	4.170
						3	4.410	4.550	4.660	4.770	4.900
						4	5.510	5.630	5.720	5.850	5.960
						5	6.690	6.830	6.880	6.970	7.090
MSVT72 Hydronic	6.0	1.00	120	VX	12 X 10	1	3.530	3.630	3.680	3.770	3.820
						2	4.600	4.680	4.760	4.850	4.910
						3	5.460	5.500	5.600	5.610	5.550
						4	6.410	6.430	6.220	6.040	5.830
						5	6.860	6.640	6.440	6.220	6.050

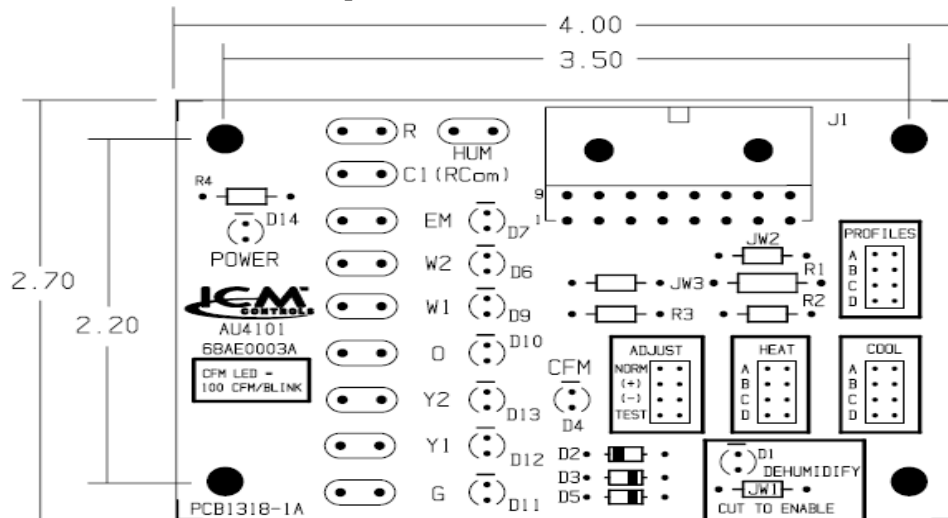
**Table 7: MSVT Blower Performance Chart – Amp Data with a X-13 Motor -Without Air Filters**

Model Number	Nominal Tons	Motor HP	Volts 1 Ph. 50/60 Hz.	Motor Code	Blower Wheel	Motor Tap	CFM @ 0.10"	CFM @ 0.20"	CFM @ 0.30"	CFM @ 0.40"	CFM @ 0.50"
MSPS18,24 Electric	1.5 & 2.0	0.33	240	RA	9 X 6	Low	859	822	776	735	674
						Med	925	881	835	779	726
						High	982	931	885	828	757
MSPS18,24 Hydronic	1.5 & 2.0	0.33	120	RJ	9 X 6	Low	772	731	683	635	569
						Med	815	764	718	665	598
						High	836	791	739	678	612
MSPS25,30,36 Electric	2.0 Thru 3.0	0.50	240	RC	10 X 7	Low	1087	1070	1035	999	941
						Med	1280	1230	1169	1115	1035
						High	1448	1378	1304	1222	1154
MSPS25,30,36 Hydronic	2.0 Thru 3.0	0.50	120	RD	10 X 7	Low	930	956	969	950	917
						Med	1206	1190	1154	1105	1043
						High	1412	1355	1281	1217	1139
MSPS37,42,48,60 Electric	3.0 Thru 5.0	0.75	240	RH	12 X 9	Low	1462	1452	1432	1402	1371
						Med	1756	1723	1689	1664	1612
						High	2092	2029	1979	1898	1852
MSPS37,42,48,60 Hydronic	3.0 Thru 5.0	0.75	120	RK	12 X 9	Low	1091	1087	1084	1078	1051
						Med	1456	1446	1446	1446	1426
						High	2231	2171	2103	2040	1989

**Table 8: MSPS Blower Performance Chart – CFM Data with a PSC Motor -Without Air Filters**

Model Number	Nominal Tons	Motor HP	Volts 1 Ph. 50/60 Hz.	Motor Code	Blower Wheel	Motor Tap	AMPS @ 0.10"	AMPS @ 0.20"	AMPS @ 0.30"	AMPS @ 0.40"	AMPS @ 0.50"
MSPS18,24 Electric	1.5 & 2.0	0.33	240	RA	9 X 6	Low	1.50	1.40	1.30	1.20	1.10
						Med	1.60	1.50	1.40	1.30	1.20
						High	1.80	1.80	1.70	1.60	1.60
MSPS18,24 Hydronic	1.5 & 2.0	0.33	120	RJ	9 X 6	Low	2.80	2.60	2.50	2.30	2.20
						Med	3.10	2.90	2.80	2.70	2.50
						High	3.70	3.60	3.50	3.40	3.30
MSPS25,30,36 Electric	2.0 Thru 3.0	0.50	240	RC	10 X 7	Low	2.70	2.40	2.30	2.10	1.90
						Med	2.80	2.60	2.40	2.30	2.10
						High	3.20	3.10	3.00	2.80	2.70
MSPS25,30,36 Hydronic	2.0 Thru 3.0	0.50	120	RD	10 X 7	Low	5.90	5.30	5.10	4.70	4.30
						Med	6.50	5.90	5.50	5.10	4.70
						High	6.70	6.30	6.00	5.70	5.40
MSPS37,42,48,60 Electric	3.0 Thru 5.0	0.75	240	RH	12 X 9	Low	3.70	3.50	3.40	3.30	3.20
						Med	4.40	4.10	4.00	3.90	3.70
						High	5.10	4.60	4.50	4.30	4.20
MSPS37,42,48,60 Hydronic	3.0 Thru 5.0	0.75	120	RK	12 X 9	Low	7.60	7.30	7.00	6.90	6.50
						Med	9.80	9.30	8.90	8.70	8.20
						High	13.40	12.90	12.60	12.10	11.90

**Table 9: MSPS Blower Performance Chart – Amp Data with a PSC Motor -Without Air Filters**



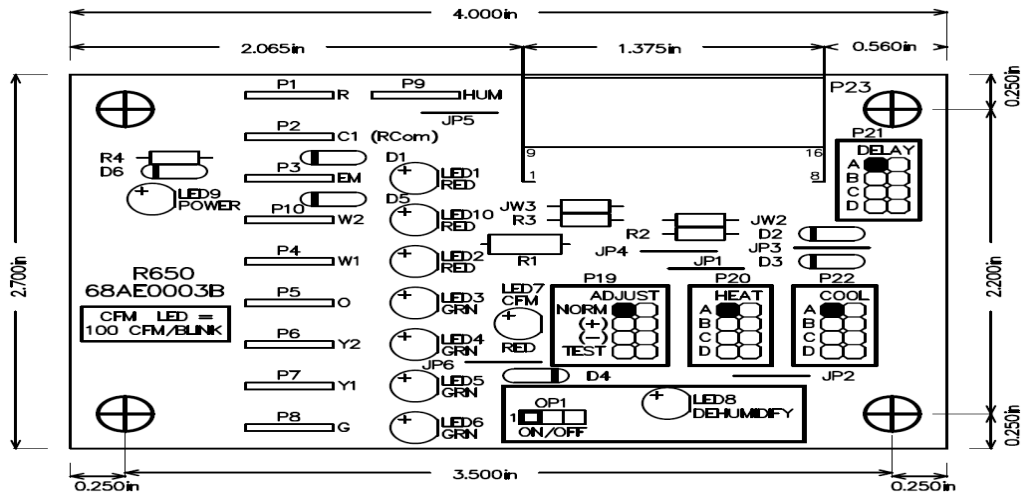


Figure 20 ECM Control Board Diagrams

Blower Performance Data - Variable Speed (High Efficiency) ECM 2.3 Motor																
Unit Size	Operating Mode	Thermostat Terminals						Control Board Taps								
		v = Energized Terminal						Cool				Heat				
		Y1	Y2	W1	W2	EM	G	HUM	A	B	C	D	A	B	C	D
		CFM	CFM	CFM	CFM	CFM	CFM	CFM	CFM	CFM	CFM	CFM	CFM	CFM	CFM	CFM
MSVE18,24	Hi Cooling / HP Heating	√	√					++	1000	900	800	700				
	Low Cooling / HP Heating	√							850	750	700	610				
	Auxiliary Heat	√	√	√					+++	+++	+++	+++	1000	900	800	700
	Emergency Heat					√			+++	+++	+++	+++	1000	900	800	700
	Continuous Blower						√		500	450	400	350				
MSVE25,30,36	Hi Cooling / HP Heating	√	√					++	1600	1400	1200	1100				
	Low Cooling / HP Heating	√		√					1500	1300	1100	1050				
	Auxiliary Heat	√	√	√					+++	+++	+++	+++	1600	1400	1200	1100
	Emergency Heat					√			+++	+++	+++	+++	1300	1175	1000	960
	Continuous Blower						√		800	700	600	550				
MSVE37,42,48,60	Hi Cooling / HP Heating	√	√					++	2100	1700	1500	1490				
	Low Cooling / HP Heating	√		√					2000	1600	1450	1350				
	Auxiliary Heat	√	√	√					+++	+++	+++	+++	2100	1700	1500	1490
	Emergency Heat					√			+++	+++	+++	+++	1800	1585	1485	1485
	Continuous Blower						√		1050	850	750	745				
MSVE72	Hi Cooling / HP Heating	√	√					++	2400	2300	2100	1900				
	Low Cooling / HP Heating	√		√					2400	2200	2000	1800				
	Auxiliary Heat	√	√	√					+++	+++	+++	+++	2400	2300	2100	1900
	Emergency Heat					√			+++	+++	+++	+++	2400	2300	2100	1900
	Continuous Blower						√		1200	1150	1050	950				

Table 10: Blower CFM For The Heat and Cool ECM Control Board Tap Selections

“+++” When auxiliary heat and heat pump are activated the airflow will increase to the higher CFM selected by the “HEAT” or “COOL” jumper pin on the ECM Board.

The “COOL” jumper pins select the CFM for both cooling or heat pump operation. Heat Pump and Cooling use different CFM Tables.

“++” Remove 24 VAC signal to “HUM” terminal by cutting the dehumidify resistor. This will cause the motor CFM to be reduced by 30%. Humidistat must be programmable to remove signal to “HUM” terminal on humidity rise. (Refer to Figure 1)

Adjust tap “+” increases airflow by 10%.

Adjust tap “-“ reduces airflow by 12%.

Adjust tap “TEST - The motor is programmed to ignore the “TEST” pin. This prevents field service personnel from leaving the jumper pin in the “TEST” mode.

“PROFILES” – Climate Profiles are used to ramp up to the selected CFM and ramp the motor down to 0 CFM depending on the climate you are residing. Refer to the Climate Profiles drawings, Figures 1 and 2 to determine what profile is best profile for your area, then, change the jumper pin under PROFILES to select the A, B, C or D profile. The Climate Profiles are the same for Cooling and Heat Pump. Profiles “E” for Electric Heat and “F” for Emergency Heat are programmed settings and are not field adjustable. Refer to Figure 2 “Electric w/ Element On and/or Off Delays” for the “E” and “F” profile.

PWM – Pulse Width Modulation – The blower motor must be returned to the factory to be reprogrammed in order to be operated in the PWM mode. It is recommended the air handler be ordered for PWM operation.

## SECTION VII: ECM 2.3 CLIMATE PROFILES

### Background

The GE ECM 2.3 motor has an extensive array of programmable features for varying airflow as a function of time. These options are beneficial to enhance comfort and efficiency in furnaces, air conditioners and heat pumps. The options are called “Delay Profiles” and “Slew Rates” and are created by OEM Design Engineers using the ECM programming software.

The delay profiles can be adjusted in the installation to optimize comfort. The ECM 2.3 supports five field selectable profiles that can be used for heating or cooling. We recommend programming the motor to use 1 heating and 4 cooling profiles. Each profile, which represents one complete thermostat cycle, has 4 unique components called PreRun, Short Run, Full Capacity, and Off Delay. In the field, profiles are selected by moving a jumper or dip switch setting. Slew rates are preprogrammed in the control memory, and are not field adjustable.

### Cooling Profiles (refer to Fig. 1)

These profiles are used to provide dehumidification and improve system efficiency.

**PreRun** allows for a reduced airflow capacity at compressor startup (“On” in the profile diagrams). In humid climates where dehumidification is highly desired, a reduced percentage of the maximum CFM can be selected to allow more moisture to collect and then drain from the coils.

**The Short Run** CFM and time can be selected to achieve various degrees of dehumidification and reduce re-evaporation. In more arid or moderate climates, these values are modified to achieve full capacity cooling in a shorter time period.

**The Off Delay** is intended to allow the blower to run for a period of time after the compressor shuts off. In arid and moderate climates this feature will evaporate moisture back into the air.

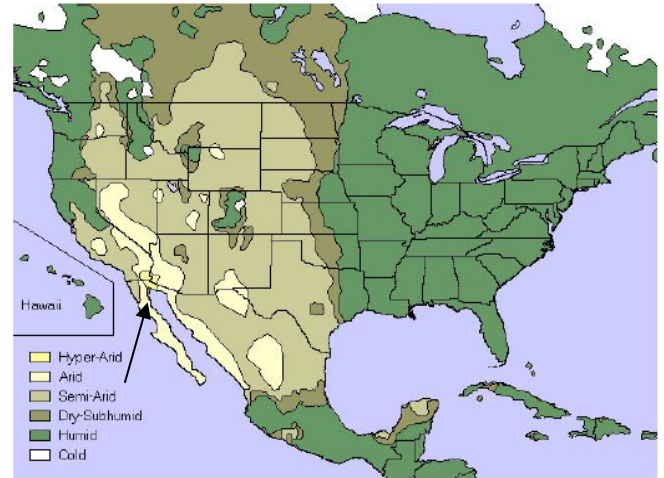
In humid climates this time is programmed to zero to minimize re-evaporation of evaporator coil and drain pan moisture back into the conditioned space.

### Heating Profiles (refer to Fig 2.)

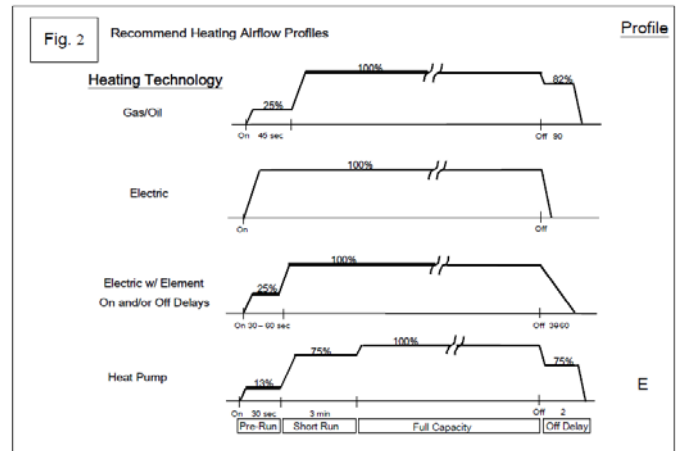
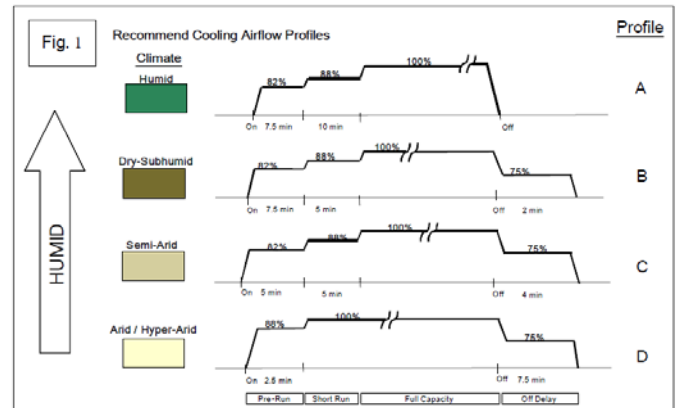
These profiles are used to provide a high degree of comfort and to improve system efficiency. There are a variety of profiles available to accommodate most popular heating technologies. It may be desirable for a **gas** or **oil furnace** to have a short PreRun delay at very low airflow until the heat exchanger is up to an adequate temperature. At the end of the heating cycle, an Off delay can be used to improve system efficiency by continuing to move air across the exchanger until the residual heat is removed. In the case of **electric heat**, a rapid On slew rate to full capacity is used to prevent overheating of the coils. Likewise, a rapid Off slew rate will prevent blowing cool air into the home after the heating coils have shut off. If thermal relays are used to control the

heating coils or if coils are staged, then the On slew, PreRun heating, and Off slew can be set at different rates to match relay performance.

Unique requirements of **heat pumps** can also be accommodated by matching delays to individual system performance characteristics. An emergency or backup profile can also be created to match system response to a call for secondary heat in the heat pump application.



NOTE: Cold area is shaded in white in Canada only.



**SECTION VIII: ACCESSORY AND REPLACEMENT PARTS LISTS**

<b>MSVE, MSVT, MSPS</b>	
<b>Part #</b>	<b>Description</b>
DFK44-12-DX	Downflow Conversion Kit - Small Cabinet - 12 Tubes High - DX Coil
DFK44-14-DX	Downflow Conversion Kit - Small Cabinet - 14 Tubes High - DX Coil
DFK44-16-DX	Downflow Conversion Kit - Small Cabinet - 16 Tubes High - DX Coil
DFK44-16-CW	Downflow Conversion Kit - Small Cabinet - 16 Tubes High - Chilled Water Coil
DFK45-14-DX	Downflow Conversion Kit - Medium Cabinet - 14 Tubes High - DX Coil
DFK45-16-DX	Downflow Conversion Kit - Medium Cabinet - 16 Tubes High - DX Coil
DFK45-18-DX	Downflow Conversion Kit - Medium Cabinet - 18 Tubes High - DX Coil
DFK45-20-DX	Downflow Conversion Kit - Medium Cabinet - 20 Tubes High - DX Coil
DFK45-20-CW	Downflow Conversion Kit - Medium Cabinet - 20 Tubes High - Chilled Water Coil
DFK18-16-DX	Downflow Conversion Kit - Large Cabinet - 16 Tubes High - DX Coil
DFK18-18-DX	Downflow Conversion Kit - Large Cabinet - 18 Tubes High - DX Coil
DFK18-20-DX	Downflow Conversion Kit - Large Cabinet - 20 Tubes High - DX Coil
DFK18-22-DX	Downflow Conversion Kit - Large Cabinet - 22 Tubes High - DX Coil
DFK18-24-DX	Downflow Conversion Kit - Large Cabinet - 24 Tubes High - DX Coil
DFK18-28-DX	Downflow Conversion Kit - Large Cabinet - 28 Tubes High - DX Coil
DFK18-28-CW	Downflow Conversion Kit - Large Cabinet - 28 Tubes High - Chilled Water Coil
BSHK05B	Small Cabinet 5 kW Heater Kit with circuit breakers
BSHK10B	Small Cabinet 10 kW Heater Kit with circuit breakers
SSHK05B	Small Cabinet 5 kW Heater Kit, no circuit breakers
SSHK10B	Small Cabinet 10 kW Heater Kit, no circuit breakers
BMHK05B	Medium Cabinet 5 kW Heater Kit with circuit breakers
BMHK10B	Medium Cabinet 10 kW Heater Kit with circuit breakers
BMHK15B	Medium Cabinet 15kW Heater Kit with circuit breakers
SMHK05B	Medium Cabinet 5 kW Heater Kit, no circuit breakers
SMHK10B	Medium Cabinet 10 kW Heater Kit, no circuit breakers
BLHK05B	Large Cabinet 5 kW Heater Kit with circuit breakers
BLHK10B	Large Cabinet 10 kW Heater Kit with circuit breakers
BLHK15B	Large Cabinet 15 kW Heater Kit with circuit breakers
BLHK20B	Large Cabinet 20 kW Heater Kit with circuit breakers
SLHK05B	Large Cabinet 5 kW Heater Kit, no circuit breakers
SLHK10B	Large Cabinet 10 kW Heater Kit, no circuit breakers
R72DB0005	Field Installed Thermal Expansion Valve - 15% Bleed - R-22 - 1.5 - 3.0 Tons
R72DB0003	Field Installed Thermal Expansion Valve - 15% Bleed - R-410A - 1.5 - 2.5 Tons
R72DB0006	Field Installed Thermal Expansion Valve - 15% Bleed - R-22 - 3.0 - 5.0 Tons
R72DB0044	Field Installed Thermal Expansion Valve - Non Bleed - R-410A - 3.5 - 6.0 Tons
86ET0001	Accessory 20 x 20 x 2 Filter Base Kit
86ET0002	Accessory 16 x 20 x 2 Filter Base Kit
86ET0003	Accessory 20 x 24 x 2 Filter Base Kit

**Table 11: MSVE, MSVT, MSPS Accessory Parts List**

## SECTION IX: REPLACEMENT PARTS LISTS

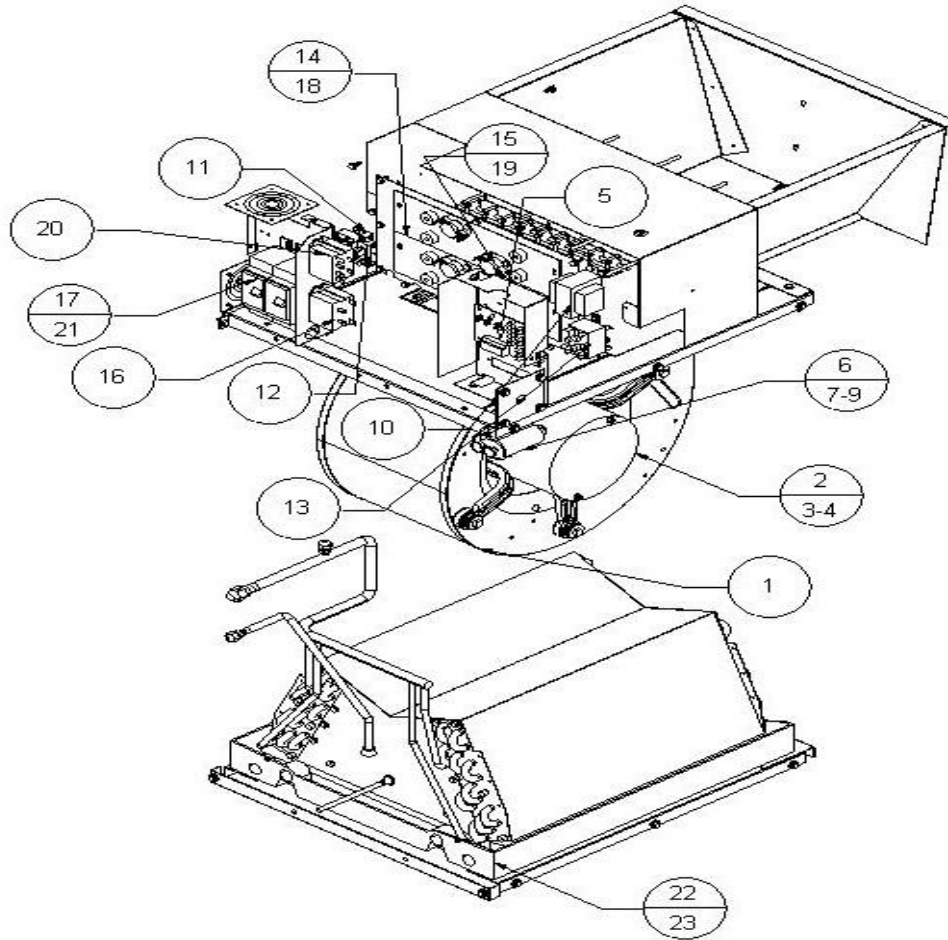


Figure 21: MS 18–24 Electric Heat Air Handler Repair Parts Schematic

<b>MS**18, 24 COOL ONLY OR ELECTRIC HEAT</b>			
<b>Item #</b>	<b>Qty.</b>	<b>Part #</b>	<b>Description</b>
1	1	R69AD0001	9 X 6 Blower Assembly
2	1	R65BV0001	1/3 HP 208/240V ECM Motor 208/240V
3	1	R65BV0025	1/3 HP 208/240V X-13 Motor 208/240V
4	1	R65BU0168	1/3 HP 208/240V PSC Motor 208/240V
5	1	R68AE0003	ECM Motor Control Board
6	1	R68DE0003	5 MFD/370V Capacitor
7	1	R68AA0003	208/240-24V Transformer
8	1	R68DC0001	Ground Lug
9	1	R68DC0018	Power Terminal Block
10	1	R68AB0001	Fan Relay for X-13 and PSC Motor
<b>5 KW Electric Heat MS**18,24</b>			
11	1	R86CG0073	5 KW Element
12	1	R68CA0003	Limit Switch
13	1	R68AB0008	Single Pole Heat Relay (X-13 & ECM Motors Only)
14	1	R68BAD013	30 Amp Circuit Breaker
<b>10 KW Electric Heat MS**18,24</b>			
15	1	R86CG0074	10 KW Element
16	2	R68CA0003	Limit Switch
17	1	R68AB0007	Double Pole Heat Relay (X-13 & ECM Motors Only)
18	1	R68BAD018	60 Amp Circuit Breaker
<b>DRAIN PANS (PLASTIC)</b>			
19	1	R86EB0202	16.625" W x 19.000" D - Vertical (71AA0013)
20	1	R86EB0252	20.250" H x 19.500" D - Horizontal (71AA0046)

Table 12: MS 18-24 Electric Heat Air Handler Repair Parts List

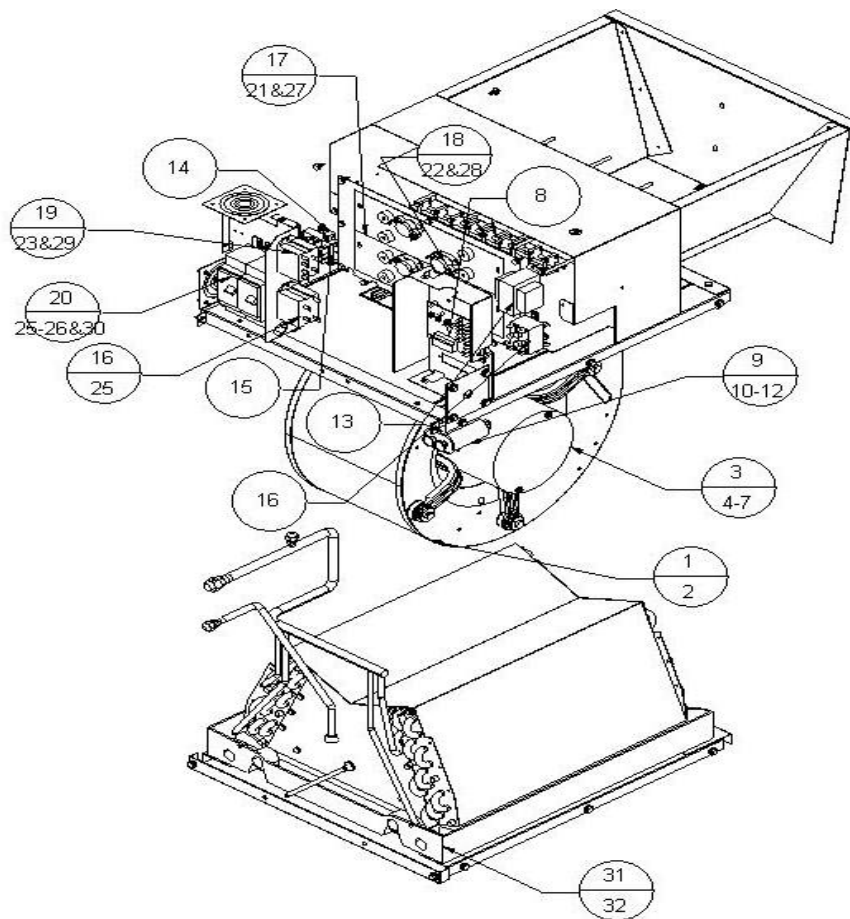


Figure 22: MS 25-30-36 Electric Heat Air Handler Repair Parts Schematic

<b>MS**25, 30, 36 COOL ONLY OR ELECTRIC HEAT</b>			
<b>Item #</b>	<b>Qty.</b>	<b>Part #</b>	<b>Description</b>
1	1	R69AD0002	10 X 7 Blower Assembly
2	1	R65BV0002	1/2 HP 208/240V ECM Motor 208/240V
3	1	R65BV0026	1/2 HP 208/240V X-13 Motor 208/240V
4	1	R65BU0159	1/2 HP 208/240V PSC Motor 208/240V
5	1	R68AE0003	ECM Motor Control Board
6	1	R68DE0001	10 MFD/370V Capacitor
7	1	R68AA0003	208/240-24V Transformer
8	1	R68DC0001	Ground Lug
9	1	R68DC0018	Power Terminal Block
10	1	R68AB0001	Fan Relay for X-13 and PSC Motor
<b>5 KW Electric Heat MS**25, 30, 36</b>			
11	1	R86CG0073	5 KW Element
12	1	R68CA0003	Limit Switch
13	1	R68AB0008	Single Pole Heat Relay (X-13 & ECM Motors Only)
14	1	R68BAD013	30 Amp Circuit Breaker
<b>10 KW Electric Heat MS**25, 30, 36</b>			
15	1	R86CG0074	10 KW Element
16	2	R68CA0003	Limit Switch
17	1	R68AB0007	Double Pole Heat Relay (X-13 & ECM Motors Only)
18	1	R68BAD018	60 Amp Circuit Breaker
<b>15 KW Electric Heat MS**25, 30, 36</b>			
19	1	R86CG0075	15 KW Element
20	3	R68CA0003	Limit Switch
21	1	R68AB0007	Double Pole Heat Relay (X-13 & ECM Motors Only)
22	1	R68AB0008	Single Pole Heat Relay (X-13 & ECM Motors Only)
23	1	R68BAD018	60 Amp Circuit Breaker
24	1	R68BAD013	30 Amp Circuit Breaker
<b>DRAIN PANS (PLASTIC)</b>			
25	1	R86EB0204	19.625" W x 19.000" D - Vertical (71AA0015)
26	1	R86EB0222	23.875" H x 19.500" D - Horizontal (71AA0031)

Table 13: MS 25-30-36 Electric Heat Air Handler Repair Parts List

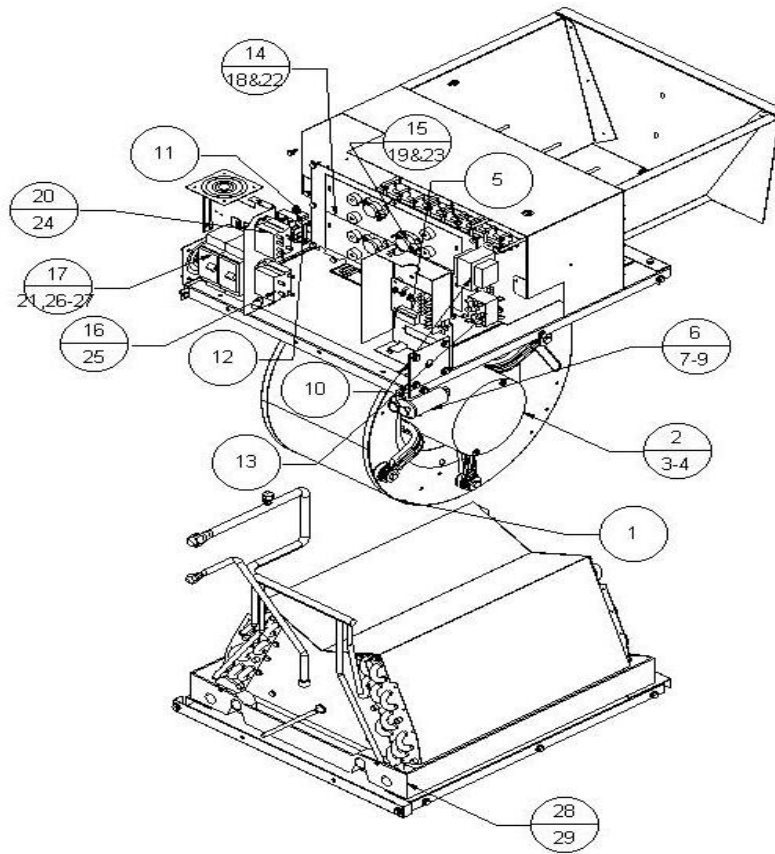


Figure 23: MS 37-42-48-60-72 Electric Heat Air Handler Repair Parts Schematic

<b>MS**37, 42, 48, 60, 72 COOL ONLY OR ELECTRIC HEAT</b>			
<b>Item #</b>	<b>Qty.</b>	<b>Part #</b>	<b>Description</b>
1	1	R69AD0017	12 x 9 Blower Assembly (MS**37,42,48,60)
2	1	R69AD0019	12 x 10 Blower Assembly (MS**72)
3	1	R65BV0003	3/4 HP 208/240V ECM Motor (MS**37,42,48,60)
4	1	R65BV0027	3/4 HP 208/240V X-13 Motor (MS**37,42,48,60)
5	1	R65BU0160	3/4 HP 208/240V PSC Motor (MS**37,42,48,60)
6	1	R65BV0004	1 HP 208/240V ECM Motor (MS**72)
7	1	R65BV0028	1 HP 208/240V X-13 Motor (MS**72)
8	1	R65BU0161	1 HP 208/240V PSC Motor (MS**72)
9	1	R68AE0003	ECM Motor Control Board
10	1	R68DE0002	15 MFD/370V Capacitor (Used on 3/4 HP PSC Motor)
11	1	R68DE0004	25 MFD/370V Capacitor (Used on 1.0 HP PSC Motor)
12	1	R68AA0003	208/240-24V Transformer
13	1	R68DC0001	Ground Lug
14	1	R68DC0018	Power Terminal Block
15	1	R68AB0001	Fan Relay for X-13 and PSC Motor
<b>10 KW Electric Heat MS**37, 42, 48, 60, 72</b>			
16	1	R86CG0074	10 KW Element
17	2	R68CA0003	Limit Switch
18	1	R68AB0007	Double Pole Heat Relay (X-13 & ECM Motors Only)
19	1	R68BAD018	60 Amp Circuit Breaker
<b>15 KW Electric Heat MS**25, 30, 36, 42, 48, 60, 72</b>			
20	1	R86CG0075	15 KW Element
21	3	R68CA0003	Limit Switch
22	1	R68AB0007	Double Pole Heat Relay (X-13 & ECM Motors Only)
23	1	R68AB0008	Single Pole Heat Relay (X-13 & ECM Motors Only)
24	1	R68BAD018	60 Amp Circuit Breaker
25	1	R68BAD013	30 Amp Circuit Breaker
<b>20 KW Electric Heat MS**37, 42, 48, 60, 72</b>			
26	2	R86CG0074	10 KW Element
27	4	R68CA0003	Limit Switch
28	2	R68AB0007	Double Pole Heat Relay (X-13 & ECM Motors Only)
29	2	R68BAD018	60 Amp Circuit Breaker
<b>DRAIN PANS (PLASTIC)</b>			
30	1	R86EB0250	23.625" W x 20.500" D - Vertical (71AA0037)
31	1	R86EB0251	32.125" H x 20.750" D - Horizontal (71AA0038)

Table 14: MS 37-42-48-60-72 Electric Heat Air Handler Repair Parts List

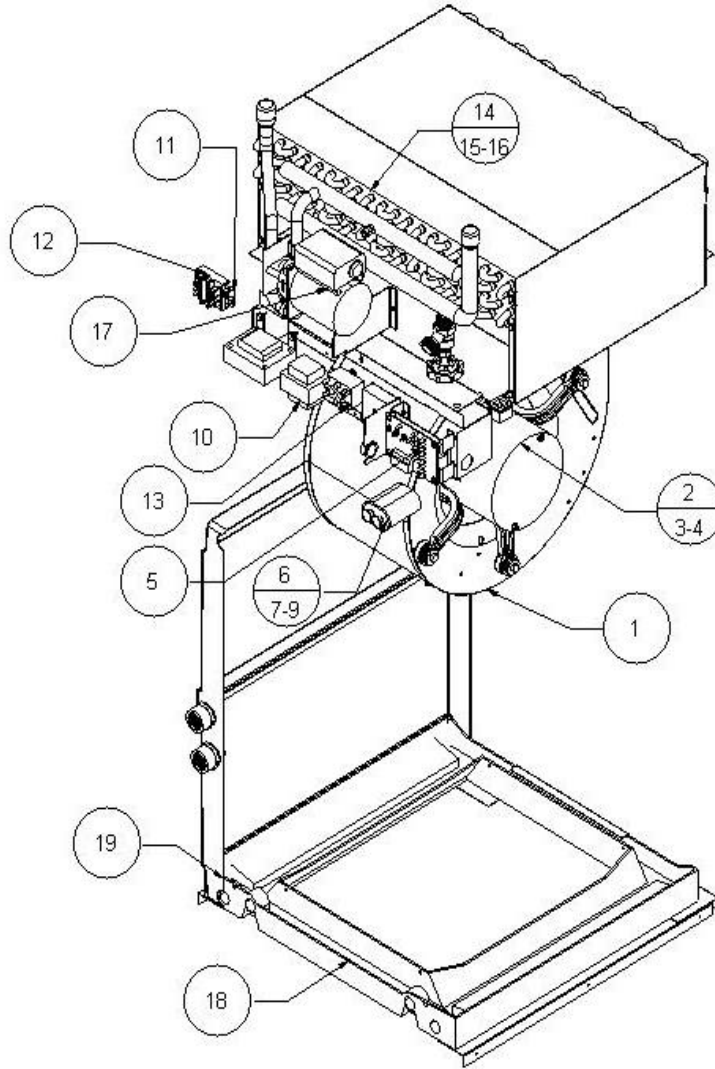


Figure 24: MS 18-24 Hydronic Heat Air Handler Repair Parts Schematic

<b>MS**18, 24 HYDRONIC HEATING</b>			
<b>Item #</b>	<b>Qty.</b>	<b>Part #</b>	<b>Description</b>
1	1	R69AD0002	10 X 7 Blower Assembly
2	1	R65BV0001	1/3 HP 120V ECM Motor
3	1	R65BV0021	1/3 HP 120V X-13 Motor
4	1	R65BU0162	1/3 HP 120V PSC Motor
5	1	R68AE0003	ECM Motor Control Board
6	1	R68DE0001	10 MFD/370V Capacitor
7	1	R68AA0002	120-24V Transformer
8	1	R68DC0001	Ground Lug
9	1	R68DC0018	Power Terminal Block
10	1	R68AB0001	Fan Relay for X-13 and PSC Motor
11	1	R86CH0017	2 Row Hydronic Coil 14.75X16
12	1	R86CH0018	3 Row Hydronic Coil 14.75X16
13	1	R86CH0025	4 Row Hydronic Coil 14.75X16
14	1	R78AA0007	3 GPM Pump 120V
<b>DRAIN PANS (PLASTIC)</b>			
15	1	R86EB0202	16.625" W x 19.000" D - Vertical (71AA0013)
16	1	R86EB0252	20.250" H x 19.500" D - Horizontal (71AA0046)

Table 15: MS 18-24 Hydronic Heat Air Handler Repair Parts List

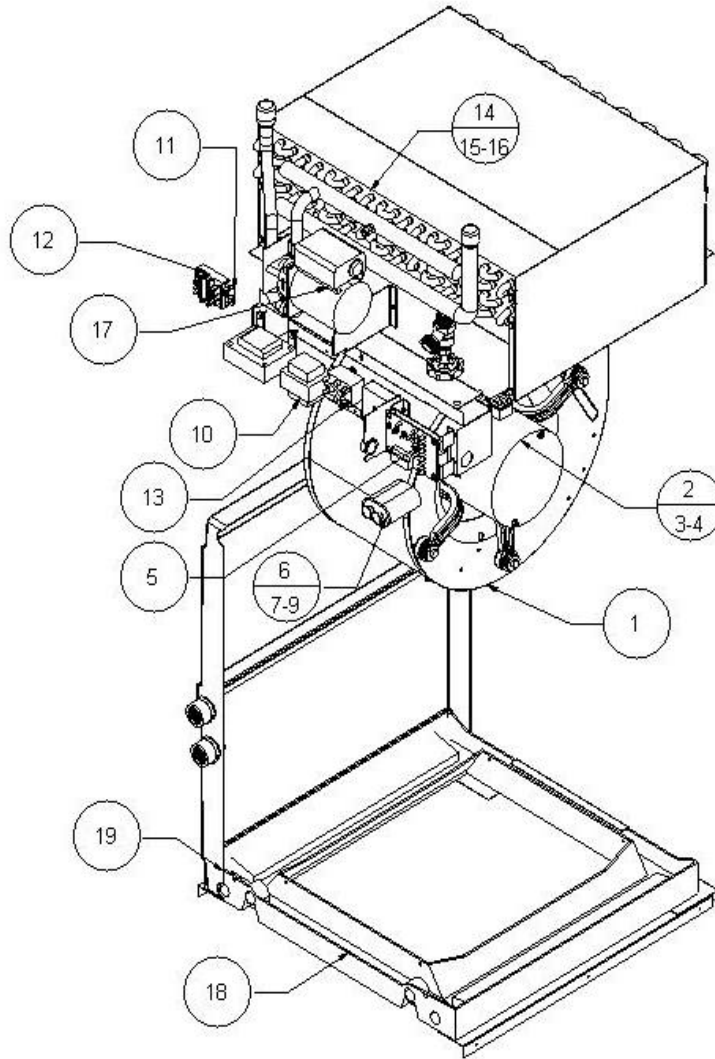


Figure 25: MS 25-30-36 Hydronic Heat Air Handler Repair Parts Schematic

MS**25, 30, 36 HYDRONIC HEATING			
Item #	Qty.	Part #	Description
1	1	R69AD0002	10 X 7 Blower Assembly
2	1	R65BV0002	1/2 HP 120V ECM Motor
3	1	R65BV0022	1/2 HP 120V X-13 Motor
4	1	R65BU0163	1/2 HP 120V PSC Motor
5	1	R68AE0003	ECM Motor Control Board
6	1	R68DE0001	10 MFD/370V Capacitor
7	1	R68AA0002	120-24V Transformer
8	1	R68DC0001	Ground Lug
9	1	R68DC0018	Power Terminal Block
10	1	R68AB0001	Fan Relay for X-13 and PSC Motor
11	1	R86CH0019	2 Row Hydronic Coil 14.75X20
12	1	R86CH0020	3 Row Hydronic Coil 14.75X20
13	1	R86CH0021	4 Row Hydronic Coil 14.75X20
14	1	R78AA0007	3 GPM Pump 120V
DRAIN PANS (PLASTIC)			
15	1	R86EB0204	19.625" W x 19.000" D - Vertical (71AA0015)
16	1	R86EB0222	23.875" H x 19.500" D - Horizontal (71AA0031)

Table 16: MS 25-30-36 Hydronic Heat Air Handler Repair Parts List

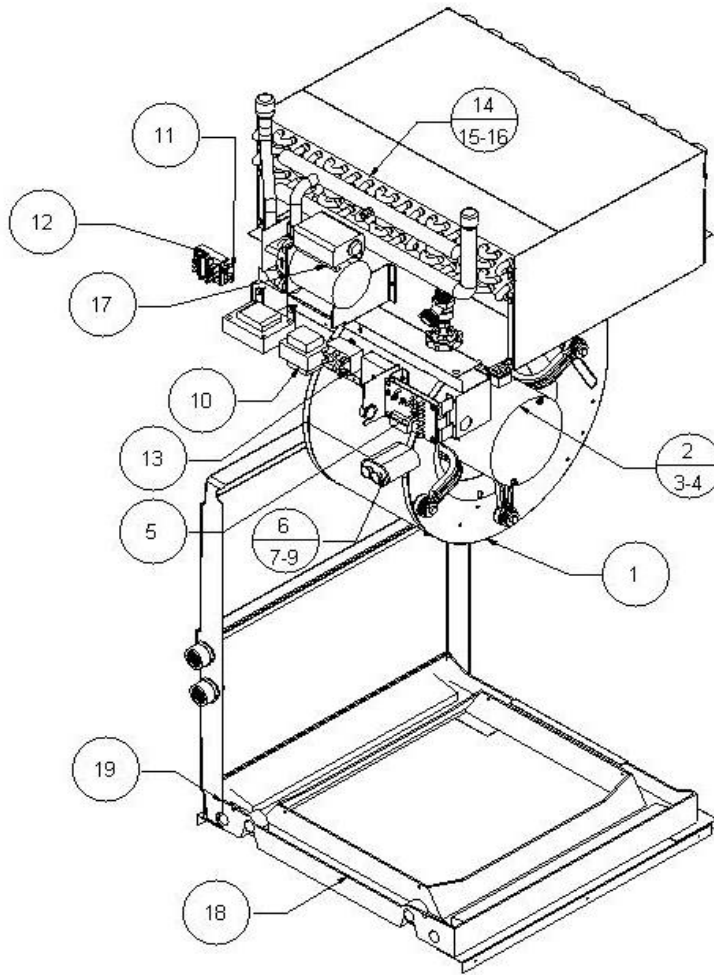


Figure 26: MS 37-42-48-60-72 Hydronic Heat Air Handler Repair Parts Schematic

MS**37, 42, 48, 60, 72 HYDRONIC HEATING			
Item #	Qty.	Part #	Description
1	1	R69AD0017	12 x 9 Blower Assembly (MS**37,42,48,60)
2	1	R69AD0019	12 x 10 Blower Assembly (MS**72)
3	1	R65BV0004	1.0 HP 120V ECM Motor
4	1	R65BV0024	1.0 HP 120V X-13 Motor
5	1	R65BU0165	1.0 HP 120V PSC Motor (Used on 72 Only)
6	1	R65BU0164	3/4 HP 120V PSC Motor (Used on 37, 42, 48 and 60)
7	1	R68AE0003	ECM Motor Control Board
8	1	R68DE0002	15 MFD/370V Capacitor (Used on 1.0 HP PSC Motor)
9	1	R68DE0004	25 MFD/370V Capacitor (Used on 3/4 HP PSC Motor)
10	1	R68AA0002	120-24V Transformer
11	1	R68DC0001	Ground Lug
12	1	R68DC0018	Power Terminal Block
13	1	R68AB0001	Fan Relay for X-13 and PSC Motor
14	1	R68AA0004	Choke
15	1	R86CH0022	2 Row Hydronic Coil 15.75X24
16	1	R86CH0023	3 Row Hydronic Coil 15.75X24
17	1	R86CH0024	4 Row Hydronic Coil 15.75X24
18	1	R78AA0008	7 GPM Pump 120V
DRAIN PANS (PLASTIC)			
19	1	R86EB0250	23.625" W x 20.500" D - Vertical (71AA0037)
20	1	R86EB0251	32.125" H x 20.750" D - Horizontal (71AA0038)

Table 17: MS 37-42-48-60-72 Hydronic Heat Air Handler Repair Parts List