



ENGLISH

FRANÇAIS

ESPAÑOL

INSTALLATION MANUAL

AIR CONDITIONER

Please read this installation manual completely before installing the product. Installation work must be performed in accordance with the national wiring standards by authorized personnel only. Please retain this installation manual for future reference after reading it thoroughly.

MULTI V™ i

Original instruction



MFL32987328
Rev.00_040925

www.lghvac.com
www.lg.com

Copyright © 2025 LG Electronics Inc. All Rights Reserved.

TIPS FOR SAVING ENERGY

Here are some tips that will help you minimize the power consumption when you use the air conditioner.

You can use your air conditioner more efficiently by referring to the instructions below:

- Do not cool excessively indoors. This may be harmful for your health and may consume more electricity.
- Block sunlight with blinds or curtains while you are operating the air conditioner.
- Keep doors or windows closed tightly while you are operating the air conditioner.
- Adjust the direction of the air flow vertically or horizontally to circulate indoor air.
- Speed up the fan to cool or warm indoor air quickly, in a short period of time.
- Open windows regularly for ventilation as the indoor air quality may deteriorate if the air conditioner is used for many hours.
- Clean the air filter once every 2 weeks. Dust and impurities collected in the air filter may block the air flow or weaken the cooling / dehumidifying functions.

For your records

Staple your receipt to this page in case you need it to prove the date of purchase or for warranty purposes.

Write the model number and the serial number here:

Model number : _____

Serial number : _____

You can find them on a label on the side of each unit.

Dealer's name : _____

Date of purchase : _____

IMPORTANT SAFETY INSTRUCTIONS

READ ALL INSTRUCTIONS BEFORE USING THE APPLIANCE.

Always comply with the following precautions to avoid dangerous situations and ensure peak performance of your product.

WARNING

It can result in serious injury or death when the directions are ignored.

CAUTION

It can result in minor injury or product damage when the directions are ignored.

WARNING

- Installation or repairs made by unqualified persons can result in hazards to you and others.
- The information contained in the manual is intended for use by a qualified service technician familiar with safety procedures and equipped with the proper tools and test instruments.
- Failure to carefully read and follow all instructions in this manual can result in equipment malfunction, property damage, personal injury and/or death.
- If the supply cord is damaged, it must be replaced by the manufacturer, its service agent or similarly qualified persons in order to avoid a hazard.

Installation

- If a stationary appliance is not fitted with a supply cord and a plug, or with other means for disconnection from supply mains having a contact separation in all poles that provide full disconnection under overvoltage category III conditions, the instructions shall state that means for disconnection must be incorporated in the fixed wiring in accordance with the wiring rules.
- Have all electric work done by a licensed electrician according to "Electric Facility Engineering Standard" and "Interior Wire Regulations" and the instructions given in this manual and always use a special circuit.
 - If the power source capacity is inadequate or electric work is performed improperly, electric shock or fire may result.
- Ask the dealer or an authorized technician to install the air conditioner.
 - Improper installation by the user may result in water leakage, electric shock, or fire.
- Always ground the product.
 - There is risk of fire or electric shock.
- Always install a dedicated circuit and breaker.
 - Improper wiring or installation may cause fire or electric shock.
- For installation, always contact a dealer or an Authorized Service Center.
 - There is risk of fire, electric shock, explosion, or injury.
- For re-installation of the installed product, always contact a dealer or an Authorized Service Center.
 - There is risk of fire, electric shock, explosion, or injury.
- Do not install, remove, or re-install the unit by yourself (customer).
 - There is risk of fire, electric shock, explosion, or injury.

4 IMPORTANT SAFETY INSTRUCTIONS

- Do not store or use flammable gas or combustibles near the air conditioner.
 - There is risk of fire or failure of product.
- Use the correctly rated breaker or fuse.
 - There is risk of fire or electric shock.
- Prepare for strong wind or earthquake and install the unit at the specified place.
 - Improper installation may cause the unit to topple and result in injury.
- Do not install the product on a defective installation stand.
 - It may cause injury, accident, or damage to the product.
- Use a vacuum pump or Inert(nitrogen) gas when doing leakage test or air purge. Do not compress air or Oxygen and do not use Flammable gases. Otherwise, it may cause fire or explosion.
 - There is the risk of death, injury, fire or explosion.
- Apply the appliance power supply before performing a leak test or air purge. If the product is operated with the power off, the pipe may be blocked and the leak test or air purge may not be fully performed.
- When installing and moving the air conditioner to another site, do not charge it with a different refrigerant from the refrigerant specified on the unit.
 - If a different refrigerant or air is mixed with the original refrigerant, the refrigerant cycle may malfunction and the unit may be damaged.
- Do not reconstruct to change the settings of the protection devices.
 - If the pressure switch, thermal switch, or other protection device is shorted and operated forcibly, or parts other than those specified by LGE are used, fire or explosion may result.
- Ventilate before operating air conditioner when gas leaked out.
 - It may cause explosion, fire, and burn.
- Securely install the cover of control box and the panel.
 - If the cover and panel are not installed securely, dust or water may enter the HR Unit and fire or electric shock may result.
- If the air conditioner is installed in a small room, measures must be taken to prevent the refrigerant concentration from exceeding the safety limit when the refrigerant leaks.
 - Consult the dealer regarding the appropriate measures to prevent the safety limit from being exceeded. Should the refrigerant leak and cause the safety limit to be exceeded, hazards due to lack of oxygen in the room could result.

Operation

- Do not damage or use an unspecified power cord.
 - There is risk of fire, electric shock, explosion, or injury.
- Use a dedicated outlet for this appliance.
 - There is risk of fire or electrical shock.
- Be cautious that water could not enter the product.
 - There is risk of fire, electric shock, or product damage.
- Do not touch the power switch with wet hands.
 - There is risk of fire, electric shock, explosion, or injury.
- When the product is soaked (flooded or submerged), contact an Authorized Service Center.
 - There is risk of fire or electric shock.
- Be cautious not to touch the sharp edges when installing.
 - It may cause injury.
- Take care to ensure that nobody could step on or fall onto the HR Unit.
 - This could result in personal injury and product damage.

CAUTION

Installation

- This appliance is not intended for the purposes of cooling INFORMATION TECHNOLOGY EQUIPMENT
- Always check for gas (refrigerant) leakage after installation or repair of product.
 - Low refrigerant levels may cause failure of product.
- Do not install the product where the noise or hot air from the HR Unit could damage the neighborhoods.
 - It may cause a problem for your neighbors.
- Keep level even when installing the product.
 - To avoid vibration or water leakage.
- Do not install the unit where combustible gas may leak.
 - If the gas leaks and accumulates around the unit, an explosion may result.
- Use power cables of sufficient current carrying capacity and rating.
 - Cables that are too small may leak, generate heat, and cause a fire.
- Do not use the product for special purposes, such as preserving foods, works of art, etc. It is a consumer air conditioner, not a precision refrigeration system.
 - There is risk of damage or loss of property.
- Keep the unit away from children. The product is very sharp.
 - It can cause the injury, such as cutting the finger. Also the damaged product may result in degradation of capacity.
- When installing the unit in a hospital, communication station, or similar place, provide sufficient protection against noise.
 - The inverter equipment, private power generator, high-frequency medical equipment, or radio communication equipment may cause the air conditioner to operate erroneously, or fail to operate. On the other hand, the air conditioner may affect such equipment by creating noise that disturbs medical treatment or image broadcasting.
- Do not install the product where it is exposed to sea wind (salt spray) directly.
 - It may cause corrosion on the product. Corrosion, particularly on the condenser and evaporator fins, could cause product malfunction or inefficient operation.
- Do not install the unit in potentially explosive atmospheres.

Operation

- Do not use the air conditioner in special environments.
 - Oil, steam, sulfuric smoke, etc. can significantly reduce the performance of the air conditioner or damage its parts.
- Do not block the inlet or outlet.
 - It may cause failure of appliance or accident.
- Make the connections securely so that the outside force of the cable may not be applied to the terminals.
 - Inadequate connection and fastening may generate heat and cause a fire.
- Be sure the installation area does not deteriorate with age.
 - If the base collapses, the air conditioner could fall with it, causing property damage, product failure, or personal injury.

6 IMPORTANT SAFETY INSTRUCTIONS

- Be very careful about product transportation.
 - Two or more people must lift and transport the product. Avoid personal injury.
 - Some products use PP bands for packaging. Do not use any PP bands for a means of transportation. It is dangerous.
 - When transporting the HR Unit, suspending it at the specified positions on the unit base. Also support the HR Unit at Three points so that it cannot slip sideways.
- Safely dispose of the packing materials.
 - Packing materials, such as nails and other metal or wooden parts, may cause stabs or other injuries.
 - Tear apart and throw away plastic packaging bags so that children may not play with them. If children play with a plastic bag which was not torn apart, they face the risk of suffocation.
- Turn on the power at least 6 hours before starting operation.
 - Starting operation immediately after turning on the main power switch can result in severe damage to internal parts. Keep the power switch turned on during the operational season.
- Do not touch any of the refrigerant piping during and after operation.
 - It can cause a burn or frostbite.
- Do not operate the air conditioner with the panels or guards removed.
 - Rotating, hot, or high-voltage parts can cause injuries.
- Do not directly turn off the main power switch after stopping operation.
 - Wait at least 5 minutes before turning off the main power switch. Otherwise it may result in water leakage or other problems.
- Auto-addressing should be done in condition of connecting the power of all indoor and outdoor units. Auto-addressing should also be done in case of changing the indoor unit PCB.
- Use a firm stool or ladder when cleaning or maintaining the air conditioner.
 - Be careful and avoid personal injury.
- Do not insert hands or other objects through the air inlet or outlet while the air conditioner is plugged in.
 - There are sharp and moving parts that could cause personal injury.
- Means for disconnection must be incorporated in the fixed wiring in accordance with the wiring rules.
- Mechanical connections (mechanical connectors or flared joints) shall be accessible for maintenance purposes.





Pipe-work shall be protected from physical damage.

When mechanical connectors are reused indoors, sealing parts shall be renewed. When flared joints are reused indoors, the flare part shall be re-fabricated. The appliance shall be installed in accordance with national wiring regulations.
- The air extraction opening in the room should be located at or below the refrigerant discharge point. For structures that are installed on the floor, they should be as low as possible. The air extraction hole should be located at a sufficient distance from the air intake to prevent recirculation into the space.
- This appliance can be used by children aged from 8 years and above and persons with reduced physical, sensory or mental capabilities or lack of experience and knowledge if they have been given supervision or instruction concerning use of the appliance in a safe way and understand the hazards involved.

Children shall not play with the appliance. Cleaning and user maintenance shall not be made by children without supervision.

- This appliance is not intended for use by persons (including children) with reduced physical, sensory or mental capabilities, or lack of experience and knowledge unless they have been given supervision or instruction concerning use of the appliance by a person responsible for their safety. Children be supervised to ensure that they do not play with the appliance.
- Auxiliary devices which can be potential ignition source shall not be installed in connecting ductwork. Examples of potential ignition sources are UV lights, electric heaters with a temperature exceeding 700 °C, pilot flames, brushed motors and similar devices.
- Pipe-work including piping material, pipe routing, and installation shall include protection from physical damage in operation and service, and be in compliance with national and local codes and standards, such as ASHRAE 15, ASHRAE 15.2, IAPMO Uniform Mechanical Code, ICC International Mechanical Code, or CSA B52. All field joints shall be accessible for inspection prior to being covered or enclosed.
- Field-made refrigerant joints indoors shall be tightness tested. The test method shall have a sensitivity of 5 grams per year of refrigerant or better under a pressure of at least 0,25 times the maximum allowable pressure. No leak shall be detected;
- An unventilated area where the appliance using flammable refrigerants is installed shall be so constructed that should any refrigerant leak, it will not stagnate so as to create a fire or explosion hazard.
- After completion of field piping for split systems, the field pipework shall be pressure tested with an inert gas and then vacuum tested prior to refrigerant charging, according to the following requirements:
 - The minimum test pressure for the low side of the system shall be the low side design pressure and the minimum test pressure for the high side of the system shall be the high side design pressure, unless the high side of the system, cannot be isolated from the low side of the system in which case the entire system shall be pressure tested to the low side design pressure.
 - The test pressure after removal of pressure source shall be maintained for at least 1 h with no decrease of pressure indicated by the test gauge, with test gauge resolution not exceeding 5% of the test pressure.During the evacuation test, after achieving a vacuum level specified in the manual or less, the refrigeration system shall be isolated from the vacuum pump and the pressure shall not rise above 1500 microns within 10 min. The vacuum pressure level shall be specified in the manual, and shall be the lessor of 500 microns or the value required for compliance with national and local codes and standards, which may vary between residential, commercial, and industrial buildings.
- Non-duct connected appliances containing A2L refrigerants with the supply and return air openings in the conditioned space may have the body of the appliance may be installed in open areas such as false ceilings not being used as return air plenums, as long as the conditioned air does not directly communicate with the air of the false ceiling.
- Flexible pipe elements shall be protected against mechanical damage, excessive stress by torsion, or other forces. They should be checked for mechanical damage annually.
- Protection devices, piping and fittings shall be protected as far as possible against adverse environmental effects, for example, the danger of water collecting and freezing in relief pipes or the accumulation of dirt and debris.
- Precautions shall be taken to avoid excessive vibration or pulsation to refrigerating piping.
- Piping in refrigerating systems shall be so designed and installed to minimize the likelihood hydraulic shock damaging the system.
- Provision shall be made for expansion and contraction of long runs of piping.
- Steel pipes and components shall be protected against corrosion with a rustproof coating before applying any insulation.

Safety precautions for R32 model

	Read the precautions in this manual carefully before operating the unit.
	This symbol indicates that the Operation Manual should be read carefully.
	This appliance is filled with flammable refrigerant (for R32)
	This symbol indicates that a service personnel should be handling this equipment with reference to the Installation Manual.

- Do not use means to accelerate the defrosting process or to clean, other than those recommended by the manufacturer.
- The appliance shall be stored in a room without continuously operating ignition sources (for example: open flames, an operating gas appliance or an operating electric heater.)
- Do not pierce or burn.
- Be aware that refrigerants may not contain an odour.
- Keep any required ventilation openings clear of obstruction
- Auxiliary devices which may be a potential ignition source shall not be installed in the duct work. Examples of such potential ignition sources are hot surfaces with a temperature exceeding X°C and electric switching devices.
- The appliance shall be stored so as to prevent mechanical damage from occurring. The manufacturer should specify other potential continuously operating sources known to cause ignition of the refrigerant used.
- Compliance with national gas regulations shall be observed
- Refrigerant tubing shall be protected or enclosed to avoid damage.
- Flexible refrigerant connectors (such as connection lines between the indoor and outdoor unit) that may be displaced during normal operations shall be protected against mechanical damage.
- The installation of pipe-work shall be kept to a minimum
- A brazed, welded, or mechanical connection shall be made before opening the valves to permit refrigerant to flow between the refrigerating system parts.
- Any person who is involved with working on or breaking into a refrigerant circuit should hold a current valid certificate from an industry-accredited assessment authority, which authorises their competence to handle refrigerants safely in accordance with an industry recognised assessment specification.
- Servicing shall only be performed as recommended by the equipment manufacturer. Maintenance and repair requiring the assistance of other skilled personnel shall be carried out under the supervision of the person competent in the use of flammable refrigerants.
- Dismantling the unit, treatment of the refrigerant oil and eventual parts should be done in accordance with local and national standards.

Checks to the area

Prior to beginning work on systems containing flammable refrigerants, safety checks are necessary to ensure that the risk of ignition is minimised. For repair to the refrigerating system, the following precautions shall be complied with prior to conducting work on the system.

Work procedure

Work shall be undertaken under a controlled procedure so as to minimise the risk of a flammable gas or vapour being present while the work is being performed.

General work area

All maintenance staff and others working in the local area shall be instructed on the nature of work being carried out. Work in confined spaces shall be avoided.

Checking for presence of refrigerant

The area shall be checked with an appropriate refrigerant detector prior to and during work, to ensure the technician is aware of potentially flammable atmospheres. Ensure that the leak detection equipment being used is suitable for use with flammable refrigerants, i.e. non-sparking, adequately sealed or intrinsically safe.

Presence of fire extinguisher

If any hot work is to be conducted on the refrigerating equipment or any associated parts, appropriate fire extinguishing equipment shall be available to hand. Have a dry powder or CO2 fire extinguisher adjacent to the charging area.

No ignition sources

No person carrying out work in relation to a refrigerating system which involves exposing any pipe work that contains or has contained flammable refrigerant shall use any sources of ignition in such a manner that it may lead to the risk of fire or explosion.

All possible ignition sources, including cigarette smoking, should be kept sufficiently far away from the site of installation, repairing, removing and disposal, during which flammable refrigerant can possibly be released to the surrounding space.

Prior to work taking place, the area around the equipment is to be surveyed to make sure that there are no flammable hazards or ignition risks. "No Smoking" signs shall be displayed.

Checks to the refrigerating equipment

Where electrical components are being changed, they shall be fit for the purpose and to the correct specification. At all times the manufacturer's maintenance and service guidelines shall be followed. If in doubt consult the manufacturer's technical department for assistance.

The following checks shall be applied to installations using flammable refrigerants:

- The actual refrigerant charge is in accordance with the room size within which the refrigerant containing parts are installed
- The ventilation machinery and outlets are operating adequately and are not obstructed
- If an indirect refrigerating circuit is being used, the secondary circuit shall be checked for the presence of refrigerant
- Marking to the equipment continues to be visible and legible. Markings and signs that are illegible shall be corrected
- Refrigerating pipe or components are installed in a position where they are unlikely to be exposed to any substance which may corrode refrigerant containing components, unless the components are constructed of materials which are inherently resistant to being corroded or are suitably protected against being so corroded.

Checks to electrical devices

Repair and maintenance to electrical components shall include initial safety checks and component inspection procedures.

If a fault exists that could compromise safety, then no electrical supply shall be connected to the circuit until it is satisfactorily dealt with. If the fault cannot be corrected immediately but it is necessary to continue operation, an adequate temporary solution shall be used. This shall be reported to the owner of the equipment so all parties are advised.

Initial safety checks shall include:

- Capacitors are discharged: this shall be done in a safe manner to avoid possibility of sparking.
- No live electrical components and wiring are exposed while charging, recovering or purging the system.
- Continuity of earth bonding

Repairs to sealed components

During repairs to sealed components, all electrical supplies shall be disconnected from the equipment being worked upon prior to any removal of sealed covers, etc.

If it is absolutely necessary to have an electrical supply to equipment during servicing, then a permanently operating form of leak detection shall be located at the most critical point to warn of a potentially hazardous situation. Particular attention shall be paid to the following to ensure that by working on electrical components, the casing is not altered in such a way that the level of protection is affected.

This shall include damage to cables, excessive number of connections, terminals not made to original specification, damage to seals, incorrect fitting of glands, etc.

Ensure that apparatus is mounted securely.

Ensure that seals or sealing materials have not degraded such that they no longer serve the purpose of preventing the ingress of flammable atmospheres. Replacement parts shall be in accordance with the manufacturer's specifications.

Repair to intrinsically safe components

Do not apply any permanent inductive or capacitance loads to the circuit without ensuring that this will not exceed the permissible voltage and current permitted for the equipment in use.

Intrinsically safe components are the only types that can be worked on while live in the presence of a flammable atmosphere. The test apparatus shall be at the correct rating. Replace components only with parts specified by the manufacturer.

Other parts may result in the ignition of refrigerant in the atmosphere from a leak.

NOTE

The use of silicon sealant can inhibit the effectiveness of some types of leak detection equipment. Intrinsically safe components do not have to be isolated prior to working on them.

Decommissioning

Before carrying out this procedure, it is essential that the technician is completely familiar with the equipment and all its detail.

It is recommended good practice that all refrigerants are recovered safely.

Prior to the task being carried out, an oil and refrigerant sample shall be taken in case analysis is required prior to re-use of recovered refrigerant.

It is essential that electrical power is available before the task is commenced.

- a) Become familiar with the equipment and its operation.
- b) Isolate system electrically.
- c) Before attempting the procedure ensure that:
 - Mechanical handling equipment is available, if required, for handling refrigerant cylinders
 - All personal protective equipment is available and being used correctly
 - The recovery process is supervised at all times by a competent person
 - Recovery equipment and cylinders conform to the appropriate standards.
- d) Pump down refrigerant system, if possible.
- e) If a vacuum is not possible, make a manifold so that refrigerant can be removed from various parts of the system.
- f) Make sure that cylinder is situated on the scales before recovery takes place.
- g) Start the recovery machine and operate in accordance with manufacturer's instructions.
- h) Do not overfill cylinders. (No more than 80 % volume liquid charge).
- i) Do not exceed the maximum working pressure of the cylinder, even temporarily.
- j) When the cylinders have been filled correctly and the process completed, make sure that the cylinders and the equipment are removed from site promptly and all isolation valves on the equipment are closed off.
- k) Recovered refrigerant shall not be charged into another refrigerating system unless it has been cleaned and checked.

Labelling

Equipment shall be labelled stating that it has been de-commissioned and emptied of refrigerant. The label shall be dated and signed. Ensure that there are labels on the equipment stating the equipment contains flammable refrigerant.

Ventilated area

Ensure that the area is in the open or that it is adequately ventilated before breaking into the system or conducting any hot work. A degree of ventilation shall continue during the period that the work is carried out. The ventilation should safely disperse any released refrigerant and preferably expel it externally into the atmosphere.

Cabling

Cabling will not be subject to wear, corrosion, excessive pressure, vibration, sharp edges or any other adverse environmental effects. The check shall also take into account the effects of ageing or continual vibration from sources such as compressors or fans.

Detection of flammable refrigerants

Under no circumstances shall potential sources of ignition be used in the searching for or detection of refrigerant leaks. A halide torch (or any other detector using a naked flame) shall not be used.

Leak detection methods

The following leak detection methods are deemed acceptable for systems containing flammable refrigerants.

Electronic leak detectors shall be used to detect flammable refrigerants, but the sensitivity may not be adequate, or may need re-calibration. (Detection equipment shall be calibrated in a refrigerant-free area.)

Ensure that the detector is not a potential source of ignition and is suitable for the refrigerant used.

Leak detection equipment shall be set at a percentage of the LFL of the refrigerant and shall be calibrated to the refrigerant employed and the appropriate percentage of gas (25 % maximum) is confirmed.

Leak detection fluids are also suitable for use with most refrigerants but the use of detergents containing chlorine shall be avoided as the chlorine may react with the refrigerant and corrode the copper pipe-work.

NOTE

Examples of leak detection fluids are.

- Bubble method.
- Fluorescent method agents.

If a leak is suspected, all naked flames shall be removed / extinguished.

If a leakage of refrigerant is found which requires brazing, all of the refrigerant shall be recovered from the system, or isolated (by means of shut off valves) in a part of the system remote from the leak. Removal of refrigerant shall be according to removal and evacuation procedure.

Removal and evacuation

When breaking into the refrigerant circuit to make repairs - or for any other purpose – conventional procedures shall be used. However, for flammable refrigerants it is important that best practice is followed since flammability is a consideration.

The following procedure shall be adhered to:

- Remove refrigerant;
- Purge the circuit with inert gas (optional for A2L);
- Evacuate (optional for A2L);
- Purge with inert gas (optional for A2L);
- Open the circuit by cutting or brazing

The refrigerant charge shall be recovered into the correct recovery cylinders. For appliances containing flammable refrigerants other than A2L refrigerants, the system shall be purged with oxygen-free nitrogen to render the appliance safe for flammable refrigerants. This process may need to be repeated several times.

Compressed air or oxygen shall not be used for purging refrigerant systems.

For appliances containing flammable refrigerants, other than A2L refrigerants, refrigerants purging shall be achieved by breaking the vacuum in the system with oxygen-free nitrogen and continuing to fill until the working pressure is achieved, then venting to atmosphere, and finally pulling down to a vacuum. This process shall be repeated until no refrigerant is within the system.

When the final oxygen-free nitrogen charge is used, the system shall be vented down to atmospheric pressure to enable work to take place. This operation is absolutely vital if brazing operations on the pipe-work are to take place. Ensure that the outlet for the vacuum pump is not close to any potential ignition sources and that ventilation is available.

Charging procedures

In addition to conventional charging procedures, the following requirements shall be followed.

- Ensure that contamination of different refrigerants does not occur when using charging equipment. Hoses or lines shall be as short as possible to minimise the amount of refrigerant contained in them.
- Cylinders shall be kept in an appropriate position according to the instruction.
- Ensure that the refrigerating system is earthed prior to charging the system with refrigerant.
- Label the system when charging is complete (if not already).
- Extreme care shall be taken not to overfill the refrigerating system.

Prior to recharging the system, it shall be pressure tested with the appropriate purging gas. The system shall be leak-tested on completion of charging but prior to commissioning. A follow up leak test shall be carried out prior to leaving the site.

Recovery

When removing refrigerant from a system, either for servicing or decommissioning, it is recommended good practice that all refrigerants are removed safely.

When transferring refrigerant into cylinders, ensure that only appropriate refrigerant recovery cylinders are employed.

Ensure that the correct number of cylinders for holding the total system charge are available. All cylinders to be used are designated for the recovered refrigerant and labelled for that refrigerant (i.e. special cylinders for the recovery of refrigerant).

Cylinders shall be complete with pressure relief valve and associated shut-off valves in good working order.

Empty recovery cylinders are evacuated and, if possible, cooled before recovery occurs. The recovery equipment shall be in good working order with a set of instructions concerning the equipment that is at hand and shall be suitable for the recovery of flammable refrigerants.

In addition, a set of calibrated weighing scales shall be available and in good working order.

Hoses shall be complete with leak-free disconnect couplings and in good condition. Before using the recovery machine, check that it is in satisfactory working order, has been properly maintained and that any associated electrical components are sealed to prevent ignition in the event of a refrigerant release.

Consult manufacturer if in doubt. The recovered refrigerant shall be returned to the refrigerant supplier in the correct recovery cylinder, and the relevant Waste Transfer Note arranged.

Do not mix refrigerants in recovery units and especially not in cylinders. If compressors or compressor oils are to be removed, ensure that they have been evacuated to an acceptable level to make certain that flammable refrigerant does not remain within the lubricant.

The evacuation process shall be carried out prior to returning the compressor to the suppliers. Only electric heating to the compressor body shall be employed to accelerate this process. When oil is drained from a system, it shall be carried out safely.

Qualification of workers

The manual shall contain specific information about the required qualification of the working personnel for maintenance, service and repair operations. Every working procedure that affects safety means shall only be carried out by qualified person by manufacturer.

Examples for such working procedures are:

- Breaking into the refrigerating circuit;
- Opening of sealed components;
- Opening of ventilated enclosures.

HR Units Installation General Information

Ducted Indoor / Air Handling Units Installation Tips

This document contains general installation tips for installing LG HR Units. Follow all applicable local and national codes during installation. For more detailed information, refer to the individual unit's installation manual on www.lghvac.com.

The typical unit installation includes:

- Minimum Floor Area
- Selecting the installation location
- Installing the unit
- Connecting refrigerant pipes
- Connecting drain pipe
- Connecting communication and power wiring
- Installing the remote controller (if applicable)

Always follow your system diagrams, including the LATS diagram (if applicable).

Minimum Floor Area

Minimum Floor Area

The appliance shall be installed, operated and stored in a room with a floor area larger than the minimum floor area. Installers must use refrigerant charge amounts that meet the requirements to comply with use conditions required in SNAP Rules.

In this manual, provide a simple method to find minimum floor area in table. For more accurate value, use LATS or-R Checker.

Multi-Split System (UL 60335-2-40:2019 Edition 3)

- Minimum floor area for Multi-Split System (UL 60335-2-40:2019 Edition 3)

Minimum floor area for Multi-Split System (UL 60335-2-40:2019 Edition 3)

The following instructions apply when two or more independently controlled HR units are installed on a single refrigeration system. Height of room where HR units are installed must be higher than 2.0 m (6.56 ft).

- Use the <Table 1> to determine the minimum floor area with m.
- If m is not in table, use the next larger value.
- m : Total refrigerant charge in system.
- Total refrigerant charge in system : factory refrigerant charge + additional refrigerant charge.
- A_{min} : minimum floor area.

NOTE

- Maximum total refrigerant charge in multi-split system is product of 15.91 kg (35.07 lbs) and number of indoor units connected with single refrigerant system, not exceed 63.64 kg (140.30 lbs)
- HR units of multi-split system shall not be used in sealed room without ventilation to the outside of the room.
- HR units of multi-split system shall not be installed on the lowest underground floor of the building.

Altitude adjustment

- The minimum floor area shall be corrected by multiplying by the altitude adjustment factor(AF) in the below table based on for building site ground level altitude (Halt) in meters(feet).

Unit : m (ft)

Halt	0	200 (656.2)	400 (1312.3)	600 (1968.5)	800 (2624.7)	1000 (3280.8)
AF	1	1	1	1	1.02	1.05
Halt	1200 (3937.0)	1400 (4593.2)	1600 (5249.3)	1800 (5905.5)	2000 (6561.7)	
AF	1.07	1.1	1.12	1.15	1.18	

<Table 1> : Table for Multi-Split System

Maximum of m is product of 15.91 kg (35.07 lbs) and Number of HR units, not exceed 63.64 kg (140.30 lbs)

Minimum floor area			
m		A _{min}	
kg	lbs	m ²	ft ²
1.85	4.07	12.10	130.25
2.00	4.40	13.08	140.80
2.20	4.85	14.38	154.79
2.40	5.29	15.69	168.89
2.60	5.73	17.00	182.99
2.80	6.17	18.31	197.09
3.00	6.61	19.61	211.09
3.20	7.05	20.92	225.19
3.40	7.49	22.23	239.29
3.60	7.93	23.53	253.28
3.80	8.37	24.84	267.38
4.00	8.81	26.15	281.48
4.20	9.25	27.46	295.58
4.40	9.70	28.76	309.58
4.60	10.14	30.07	323.68
4.80	10.58	31.38	337.78
5.00	11.02	32.68	351.77
5.20	11.46	33.99	365.87
5.40	11.90	35.30	379.97
5.60	12.34	36.61	394.07
5.80	12.78	37.91	408.06
6.00	13.22	39.22	422.17
6.20	13.66	40.53	436.27
6.40	14.10	41.84	450.37
6.60	14.55	43.14	464.36
6.80	14.99	44.45	478.46
7.00	15.43	45.76	492.56
7.20	15.87	47.06	506.55
7.40	16.31	48.37	520.66
7.60	16.75	49.68	534.76
7.80	17.19	50.99	548.86
8.00	17.63	52.29	562.85
8.20	18.07	53.60	576.95
8.40	18.51	54.91	591.05
8.60	18.95	56.21	605.04
8.80	19.40	57.52	619.15
9.00	19.84	58.83	633.25

Minimum floor area			
m		A _{min}	
kg	lbs	m ²	ft ²
9.20	20.28	60.14	647.35
9.40	20.72	61.44	661.34
9.60	21.16	62.75	675.44
9.80	21.60	64.06	689.54
10.00	22.04	65.36	703.53
10.20	22.48	66.67	717.63
10.40	22.92	67.98	731.74
10.60	23.36	69.29	745.84
10.80	23.80	70.59	759.83
11.00	24.25	71.90	773.93
11.20	24.69	73.21	788.03
11.40	25.13	74.51	802.02
11.60	25.57	75.82	816.12
11.80	26.01	77.13	830.23
12.00	26.45	78.44	844.33
12.20	26.89	79.74	858.32
12.40	27.33	81.05	872.42
12.60	27.77	82.36	886.52
12.80	28.21	83.67	900.62
13.00	28.66	84.97	914.61
13.20	29.10	86.28	928.72
13.40	29.54	87.59	942.82
13.60	29.98	88.89	956.81
13.80	30.42	90.20	970.91
14.00	30.86	91.51	985.01
14.20	31.30	92.82	999.11
14.40	31.74	94.12	1013.10
14.60	32.18	95.43	1027.20
14.80	32.62	96.74	1041.31
15.00	33.06	98.04	1055.30
15.20	33.51	99.35	1069.40
15.40	33.95	100.66	1083.50
15.60	34.39	101.97	1097.60
15.80	34.83	103.27	1111.59
16.00	35.27	104.58	1125.69
16.20	35.71	105.89	1139.80
16.40	36.15	107.19	1153.79

Minimum floor area			
m		A _{min}	
kg	lbs	m ²	ft ²
16.60	36.59	108.50	1167.89
16.80	37.03	109.81	1181.99
17.00	37.47	111.12	1196.09
17.20	37.91	112.42	1210.08
17.40	38.36	113.73	1224.18
17.60	38.80	115.04	1238.29
17.80	39.24	116.34	1252.28
18.00	39.68	117.65	1266.38
18.20	40.12	118.96	1280.48
18.40	40.56	120.27	1294.58
18.60	41.00	121.57	1308.57
18.80	41.44	122.88	1322.67
19.00	41.88	124.19	1336.78
19.20	42.32	125.50	1350.88
19.40	42.76	126.80	1364.87
19.60	43.21	128.11	1378.97
19.80	43.65	129.42	1393.07
20.00	44.09	130.72	1407.06
20.20	44.53	132.03	1421.16
20.40	44.97	133.34	1435.26
20.60	45.41	134.65	1449.37
20.80	45.85	135.95	1463.36
21.00	46.29	137.26	1477.46
21.20	46.73	138.57	1491.56
21.40	47.17	139.87	1505.55
21.60	47.61	141.18	1519.65
21.80	48.06	142.49	1533.75
22.00	48.50	143.80	1547.86
22.20	48.94	145.10	1561.85
22.40	49.38	146.41	1575.95
22.60	49.82	147.72	1590.05
22.80	50.26	149.02	1604.04
23.00	50.70	150.33	1618.14
23.20	51.14	151.64	1632.24
23.40	51.58	152.95	1646.35
23.60	52.02	154.25	1660.34
23.80	52.47	155.56	1674.44
24.00	52.91	156.87	1688.54
24.20	53.35	158.17	1702.53
24.40	53.79	159.48	1716.63

Minimum floor area			
m		A _{min}	
kg	lbs	m ²	ft ²
24.60	54.23	160.79	1730.73
24.80	54.67	162.10	1744.83
25.00	55.11	163.40	1758.83
25.20	55.55	164.71	1772.93
25.40	55.99	166.02	1787.03
25.60	56.43	167.33	1801.13
25.80	56.87	168.63	1815.12
26.00	57.32	169.94	1829.22
26.20	57.76	171.25	1843.32
26.40	58.20	172.55	1857.32
26.60	58.64	173.86	1871.42
26.80	59.08	175.17	1885.52
27.00	59.52	176.48	1899.62
27.20	59.96	177.78	1913.61
27.40	60.40	179.09	1927.71
27.60	60.84	180.40	1941.81
27.80	61.28	181.70	1955.81
28.00	61.72	183.01	1969.91
28.20	62.17	184.32	1984.01
28.40	62.61	185.63	1998.11
28.60	63.05	186.93	2012.10
28.80	63.49	188.24	2026.20
29.00	63.93	189.55	2040.30
29.20	64.37	190.85	2054.30
29.40	64.81	192.16	2068.40
29.60	65.25	193.47	2082.50
29.80	65.69	194.78	2096.60
30.00	66.13	196.08	2110.59
30.20	66.57	197.39	2124.69
30.40	67.02	198.70	2138.79
30.60	67.46	200.00	2152.79
30.80	67.90	201.31	2166.89
31.00	68.34	202.62	2180.99
31.20	68.78	203.93	2195.09
31.40	69.22	205.23	2209.08
31.60	69.66	206.54	2223.18
31.80	70.10	207.85	2237.28
32.00	70.54	209.16	2251.38
32.20	70.98	210.46	2265.38
32.40	71.42	211.77	2279.48

Minimum floor area			
m		A _{min}	
kg	lbs	m ²	ft ²
32.60	71.87	213.08	2293.58
32.80	72.31	214.38	2307.57
33.00	72.75	215.69	2321.67
33.20	73.19	217.00	2335.77
33.40	73.63	218.31	2349.87
33.60	74.07	219.61	2363.87
33.80	74.51	220.92	2377.97
34.00	74.95	222.23	2392.07
34.20	75.39	223.53	2406.06
34.40	75.83	224.84	2420.16
34.60	76.27	226.15	2434.26
34.80	76.72	227.46	2448.36
35.00	77.16	228.76	2462.36
35.20	77.60	230.07	2476.46
35.40	78.04	231.38	2490.56
35.60	78.48	232.68	2504.55
35.80	78.92	233.99	2518.65
36.00	79.36	235.30	2532.75
36.20	79.80	236.61	2546.85
36.40	80.24	237.91	2560.85
36.60	80.68	239.22	2574.95
36.80	81.13	240.53	2589.05
37.00	81.57	241.84	2603.15
37.20	82.01	243.14	2617.14
37.40	82.45	244.45	2631.24
37.60	82.89	245.76	2645.34
37.80	83.33	247.06	2659.34
38.00	83.77	248.37	2673.44
38.20	84.21	249.68	2687.54
38.40	84.65	250.99	2701.64
38.60	85.09	252.29	2715.63
38.80	85.53	253.60	2729.73
39.00	85.98	254.91	2743.83
39.20	86.42	256.21	2757.83
39.40	86.86	257.52	2771.93
39.60	87.30	258.83	2786.03
39.80	87.74	260.14	2800.13
40.00	88.18	261.44	2814.12
40.20	88.62	262.75	2828.22
40.40	89.06	264.06	2842.32

Minimum floor area			
m		A _{min}	
kg	lbs	m ²	ft ²
40.60	89.50	265.36	2856.32
40.80	89.94	266.67	2870.42
41.00	90.38	267.98	2884.52
41.20	90.83	269.29	2898.62
41.40	91.27	270.59	2912.61
41.60	91.71	271.90	2926.71
41.80	92.15	273.21	2940.81
42.00	92.59	274.51	2954.81
42.20	93.03	275.82	2968.91
42.40	93.47	277.13	2983.01
42.60	93.91	278.44	2997.11
42.80	94.35	279.74	3011.10
43.00	94.79	281.05	3025.20
43.20	95.23	282.36	3039.30
43.40	95.68	283.67	3053.40
43.60	96.12	284.97	3067.40
43.80	96.56	286.28	3081.50
44.00	97.00	287.59	3095.60
44.20	97.44	288.89	3109.59
44.40	97.88	290.20	3123.69
44.60	98.32	291.51	3137.79
44.80	98.76	292.82	3151.89
45.00	99.20	294.12	3165.89
45.20	99.64	295.43	3179.99
45.40	100.08	296.74	3194.09
45.60	100.53	298.04	3208.08
45.80	100.97	299.35	3222.18
46.00	101.41	300.66	3236.28
46.20	101.85	301.97	3250.38
46.40	102.29	303.27	3264.38
46.60	102.73	304.58	3278.48
46.80	103.17	305.89	3292.58
47.00	103.61	307.19	3306.57
47.20	104.05	308.50	3320.67
47.40	104.49	309.81	3334.77
47.60	104.94	311.12	3348.87
47.80	105.38	312.42	3362.87
48.00	105.82	313.73	3376.97
48.20	106.26	315.04	3391.07
48.40	106.70	316.34	3405.06

Minimum floor area			
m		A _{min}	
kg	lbs	m ²	ft ²
48.60	107.14	317.65	3419.16
48.80	107.58	318.96	3433.26
49.00	108.02	320.27	3447.36
49.20	108.46	321.57	3461.36
49.40	108.90	322.88	3475.46
49.60	109.34	324.19	3489.56
49.80	109.79	325.50	3503.66
50.00	110.23	326.80	3517.65
50.20	110.67	328.11	3531.75
50.40	111.11	329.42	3545.85
50.60	111.55	330.72	3559.85
50.80	111.99	332.03	3573.95
51.00	112.43	333.34	3588.05
51.20	112.87	334.65	3602.15
51.40	113.31	335.95	3616.14
51.60	113.75	337.26	3630.24
51.80	114.19	338.57	3644.34
52.00	114.64	339.87	3658.34
52.20	115.08	341.18	3672.44
52.40	115.52	342.49	3686.54
52.60	115.96	343.80	3700.64
52.80	116.40	345.10	3714.63
53.00	116.84	346.41	3728.73
53.20	117.28	347.72	3742.83
53.40	117.72	349.02	3756.83
53.60	118.16	350.33	3770.93
53.80	118.60	351.64	3785.03
54.00	119.04	352.95	3799.13
54.20	119.49	354.25	3813.12
54.40	119.93	355.56	3827.22
54.60	120.37	356.87	3841.32
54.80	120.81	358.17	3855.31
55.00	121.25	359.48	3869.42
55.20	121.69	360.79	3883.52
55.40	122.13	362.10	3897.62
55.60	122.57	363.40	3911.61
55.80	123.01	364.71	3925.71
56.00	123.45	366.02	3939.81
56.20	123.89	367.33	3953.91
56.40	124.34	368.63	3967.91



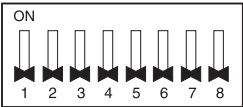

Minimum floor area			
m		A _{min}	
kg	lbs	m ²	ft ²
56.60	124.78	369.94	3982.01
56.80	125.22	371.25	3996.11
57.00	125.66	372.55	4010.10
57.20	126.10	373.86	4024.20
57.40	126.54	375.17	4038.30
57.60	126.98	376.48	4052.40
57.80	127.42	377.78	4066.40
58.00	127.86	379.09	4080.50
58.20	128.30	380.40	4094.60
58.40	128.74	381.70	4108.59
58.60	129.19	383.01	4122.69
58.80	129.63	384.32	4136.79
59.00	130.07	385.63	4150.89
59.20	130.51	386.93	4164.88
59.40	130.95	388.24	4178.99
59.60	131.39	389.55	4193.09
59.80	131.83	390.85	4207.08
60.00	132.27	392.16	4221.18
60.20	132.71	393.47	4235.28
60.40	133.15	394.78	4249.38
60.60	133.60	396.08	4263.37
60.80	134.04	397.39	4277.48
61.00	134.48	398.70	4291.58
61.20	134.92	400.00	4305.57
61.40	135.36	401.31	4319.67
61.60	135.80	402.62	4333.77
61.80	136.24	403.93	4347.87
62.00	136.68	405.23	4361.86
62.20	137.12	406.54	4375.97
62.40	137.56	407.85	4390.07
62.60	138.00	409.16	4404.17
62.80	138.45	410.46	4418.16
63.00	138.89	411.77	4432.26
63.20	139.33	413.08	4446.36
63.40	139.77	414.38	4460.35
63.60	140.21	415.69	4474.45
63.64	140.30	415.95	4477.25

THE METHOD OF CHECKING VALVE STATUS

Switch for Setup of HR Unit

SW		Function
SVC Display PCB		DIP_SW01 (7Pin DIP SW) - Checking valve status

Valve status display of 7-Segment (Standard of open: More than 200 pulse)

Valve type	Cooling valve open	Heating valve open	Balancing valve open	Liquid shut off valve open	Gas shut off valve open
7-SEG Display					

Example of Checking valve status

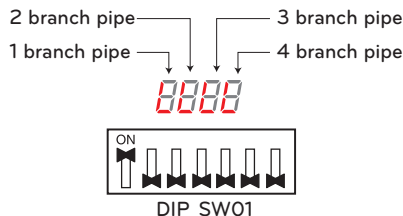
No.	Display and setup	Setup and contents
1		<ul style="list-style-type: none"> - Operation: Turn DIP switch No.1 on. - Display: "LLLL" is displayed in 7-SEG - Valve status: Cooling, liquid shut off, gas shut off valve OPEN (1,2,3,4 branches)

NOTE

* The valve will be closed for 280 seconds after power is applied to the HR Unit.

⚠ WARNING

When servicing the product, please note that even if the power is turned off, if the emergency power of SMPS remains, the product may continue to operate.

- It may cause injury.

TABLE OF CONTENTS

2 TIPS FOR SAVING ENERGY

3 IMPORTANT SAFETY INSTRUCTIONS

20 THE METHOD OF CHECKING VALVE STATUS

- 20 Example of Checking valve status
- 20 Valve status display of 7-Segment (Standard of open: More than 200 pulse)
- 20 Switch for Setup of HR Unit

22 FEATURES

23 INSTALLATION PART

- 24 Dimensional drawings

24 INSTALLATION

- 24 Selection of the best location
- 26 HR Unit Installation
- 27 Connecting the Strainer
- 30 Connecting the drain hose
- 30 Drain test
- 31 Insulation
- 32 Plumbing materials and storage methods
- 33 Wiring Connection
- 34 Electric Characteristics
- 35 Wiring of main power supply and equipment capacity
- 37 HR Unit PCB
- 38 Setup the switch of HR Unit

44 COIL EXCHANGING METHOD

45 JOINT METHOD OF HR UNIT

FEATURES

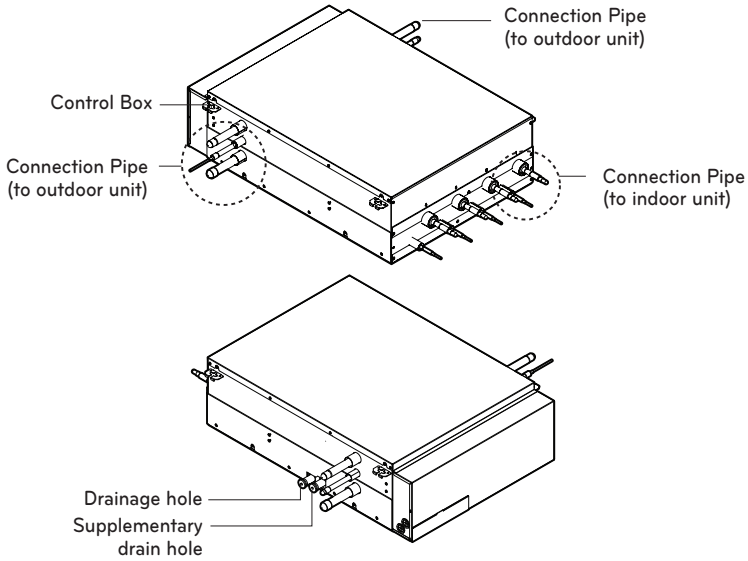





Type of HR unit		2 port HR unit	3 port HR unit	4 port HR unit	
Max. Connectable No. of Indoor Units		16	24	32	
Max. Connectable No. of Indoor Units of a branch		8	8	8	
Nominal Input	Cooling [W]	49.2			
	Heating [W]	46.6			
Net. Weight	kg	31.9	35.0	39.1	
	lbs	70.3	77.2	86.2	
Dimensions (WxHxD)	mm	955 X 270 X 1063.4			
	Inch	37-19/32 X 10-5/8 X 41-55/64			
Casing		Galvanized steel plate			
Connecting Pipes	Indoor side	Liquid Pipe [mm]	Ø 9.52 (3/8) - Ø 6.35 (1/4)		
		Gas Pipe [mm]	Ø 15.88 (5/8) - Ø 12.7 (1/2)		
	Outdoor side	Liquid [mm]	Ø 9.52 (3/8)	Ø 12.7 (1/2)	Ø 15.88 (5/8)
		Low Pressure [mm]	Ø 22.2 (7/8)	Ø 28.58 (1-1/8)	Ø 28.58 (1-1/8)
		High Pressure [mm]	Ø 19.05 (3/4)	Ø 22.2(7/8)	Ø 22.2(7/8)
Current	Minimum circuit Amps(MCA)	0.875			
	Maximum fuse Amps(MFA)	15			
Power Supply		1Ø, 208/230 V, 60 Hz			

INSTALLATION PART

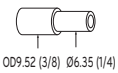
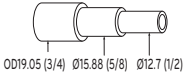
- Installation Manual
- Hanging bolts (4 x M10 or M8), Nut(8 x M10 or M8), Flat washers(8 x M10) : Field supply
- Reducers
- Strainer
- Metal clamp

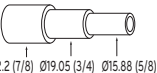
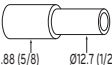
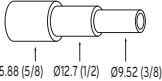
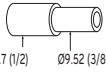
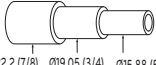
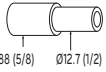
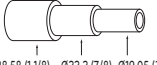
[Unit : mm (inch)]

Type of HR unit		Liquid pipe	Gas pipe	
			High pressure	Low pressure
HR unit reducer	2 port	 <p>OD9.52 (3/8) Ø6.35 (1/4)</p>	 <p>OD19.05 (3/4) Ø15.88 (5/8) Ø12.7 (1/2)</p>  <p>OD12.7 (1/2) Ø9.52 (3/8)</p>	 <p>OD22.2 (7/8) Ø19.05 (3/4) Ø15.88 (5/8)</p>  <p>OD15.88 (5/8) Ø12.7 (1/2)</p>
	3 port 4 port	 <p>OD15.88 (5/8) Ø12.7 (1/2) Ø9.52 (3/8)</p>  <p>OD12.7 (1/2) Ø9.52 (3/8)</p>	 <p>OD22.2 (7/8) Ø19.05 (3/4) Ø15.88 (5/8)</p>  <p>OD15.88 (5/8) Ø12.7 (1/2)</p>	 <p>OD28.58 (1 1/8) Ø22.2 (7/8) Ø19.05 (3/4)</p>  <p>OD19.05 (3/4) Ø15.88 (5/8)</p>

Models		High pressure gas pipe
Strainer	3 port 4 port	

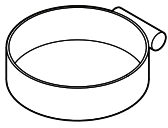
Models		Drainage hole
Metal clamp		

* When connecting the strainer directly to the HR unit. (Except PRHR023C)

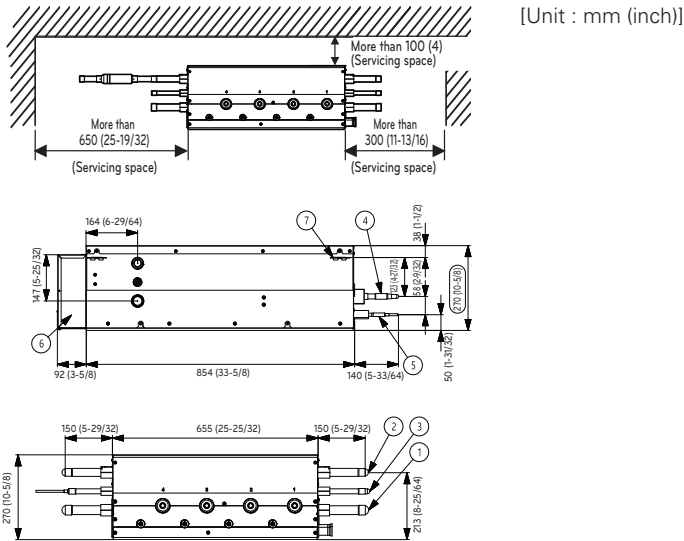

[Unit : mm (inch)]

No.	Part Name	Type of HR unit	
		3 port / 4 port	2 port
		Description	
1	Low pressure Gas pipe connection port	Ø 28.58 Brazing connection	Ø 22.2 Brazing connection
2	High pressure Gas pipe connection port	Ø 22.2 Brazing connection	Ø 19.05 Brazing connection
3	Liquid pipe connection port	Ø 15.88 Brazing connection (In a type of 3 port HR unit, use Ø12.7)	Ø 9.52 Brazing connection
4	Indoor unit Gas pipe connection port	Ø 15.88 – Ø 12.7 Brazing connection	Ø 15.88 – Ø 12.7 Brazing connection
5	Indoor unit Liquid pipe connection port	Ø 9.52 – Ø6.35 Brazing connection	Ø 9.52 – Ø 6.35 Brazing connection
6	Control box	-	-
7	Hanger metal	Suspension bolt M10 or M8	Suspension bolt M10 or M8
8	Drain hole	Connect the drain hose of ID25.4. Must be tighten the metal clamp	

NOTE

- * Be sure to install the inspection door at the electric control side.
- ** If reducers are used, servicing space must be increased equal to reducer's dimension.

HR Unit Installation

- Select and mark the position for fixing bolts.
- Drill the hole for set anchor on the face of ceiling.

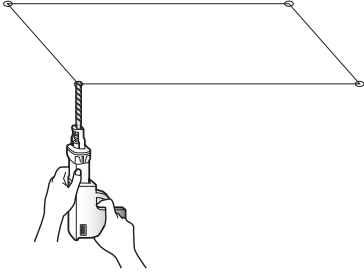

CAUTION

Tighten the nut and bolt to prevent unit falling.

- Insert the set anchor and washer onto the suspension bolts for locking the suspension bolts on the ceiling.
- Mount the suspension bolts to the set anchor firmly.
- Secure the installation plates onto the suspension bolts (adjust level roughly) using nuts, washers and spring washers.

- 1 Using an insert-hole-in-a-anchor, hang the suspension bolt.
- 2 Install a six-sided nut and a flat washer (locally-procured) to the suspension bolt as shown in the figure in the bottom, and fit the main unit to hang on the hanger metal.
- 3 After checking with a level that the unit is level, tighten the hexagon nut.
 - * The tilt of the unit should be within $\pm 5^\circ$ in front/back and left/right.
- 4 This unit should be installed suspended from ceiling and side A should always be facing up.

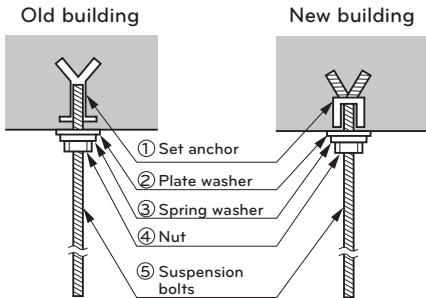
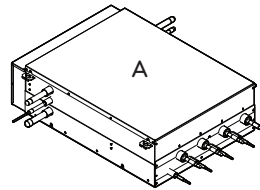
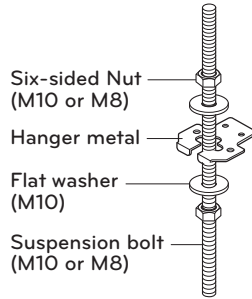

Connecting the Strainer

- Connect the strainer to the HR unit directly.

If there is not enough space to install the strainer, install it between the outdoor unit and the HR unit connection pipe. The distance between the strainer and the HR unit should be within 3 m.

1 Parallel connection with the HR unit (Except PRHR023C)

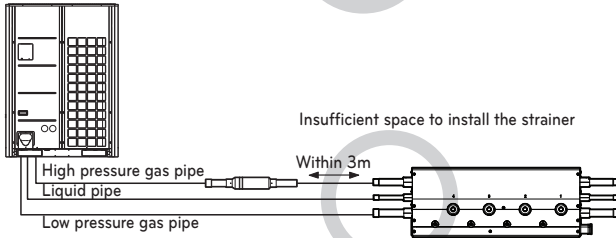
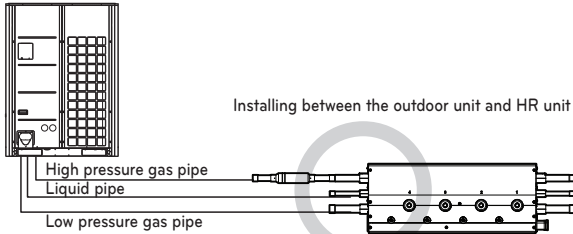

2 Serial connection with the HR unit (Except PRHR023C)

- When connecting the HR unit in a series, the first strainer is mounted between the outdoor unit and the HR unit, and the next strainer is mounted between the previous HR unit and the next HR unit.

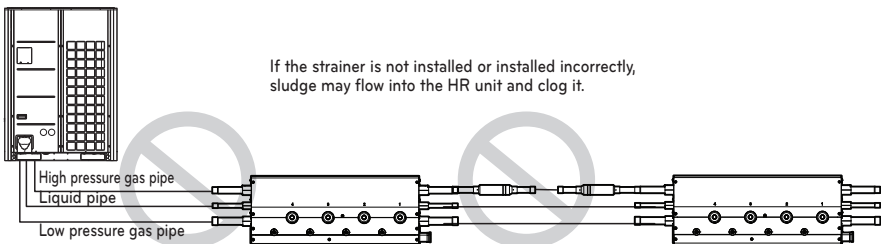
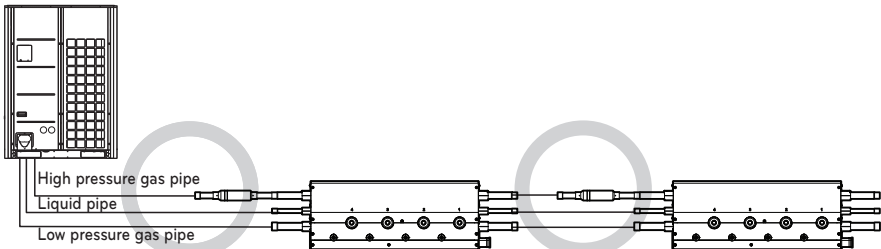

! CAUTION

HR Unit should be installed that top side is facing up. If not, it may cause failure of the product.

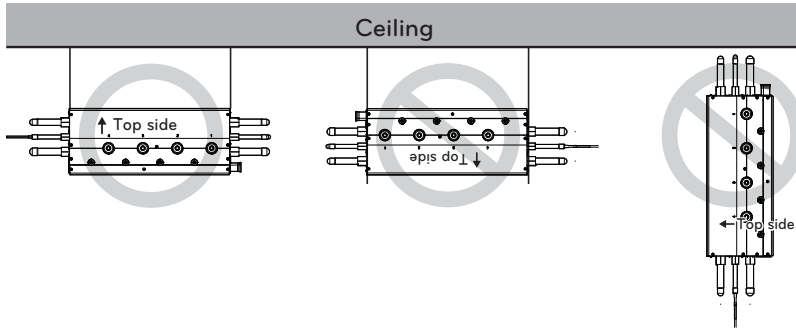

Checking the safe handling

Mark refrigerant pipes with red Pantone® Matching System (PMS) #185 or RAL 3020 after flare fittings or brazing. This marking must extend a minimum of 1 inch (25mm) in both directions and shall be replaced if removed.

Return all labels, especially red marking, to their original condition to ensure the next consumer or servicer is aware of the presence of a flammable refrigerant.

Ensure that the red marking for flammable refrigerant identification in the process tube area is visible following servicing.

⚠ WARNING

Before brazing work, remove gas in the HR Unit by cutting the three pipes in the small circles on the figure. If not, it may cause injuries. Remove the caps before connecting pipes.

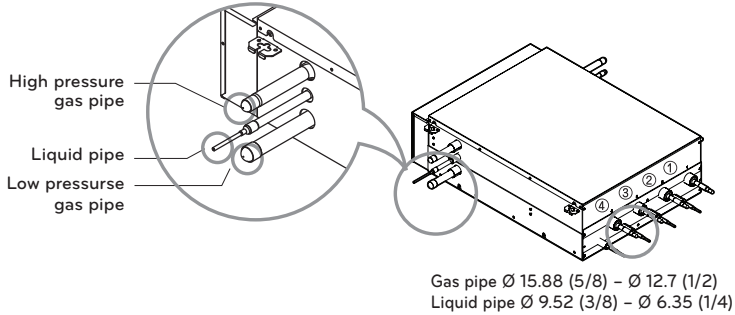

Connect after removing the cap.

Connect the strainer which is provided as an accessory to the HR unit's high pressure gas pipe.

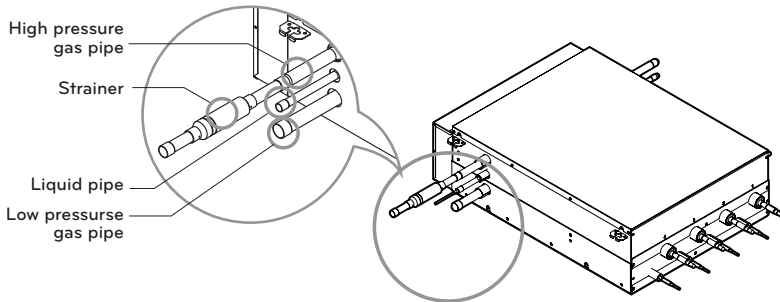

After considering the indoor unit capacity, determine the pipe sizes and cut the pipes connected to the indoor unit.

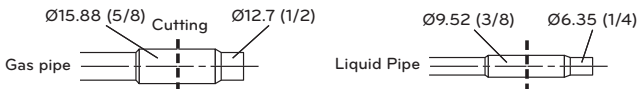

⚠ CAUTION

- Whenever connecting the indoor units with the HR unit, install the indoor units in numerical order from No.1.
Ex) In case of installing 3 indoor units : No. 1, 2, 3 (O), No. 1, 2, 4 (X), No. 1, 3, 4 (X), No. 2, 3, 4 (X).
- Take care of no thermal damage on the valves of the HR unit. (Especially packing part of valve) Wrap the valve with a wet towel when brazing it.

Connecting the drain hose

! CAUTION

Improper connection to the drain hose can cause a leak. In this case, it may damage the installation space and the surrounding environment.

NOTE

When connecting drain pipes, the pipe must be laid with a downward slope (1/50 to 1/100).
: Be sure not to provide up-and-down slope to prevent reversal flow.

- 1 Fit the drain hose(field supply-ID25.4) into the drainage hole.
- 2 Squeeze the metal clamp as closely as possible over the drain hose.
- 3 Tighten the metal clamp.

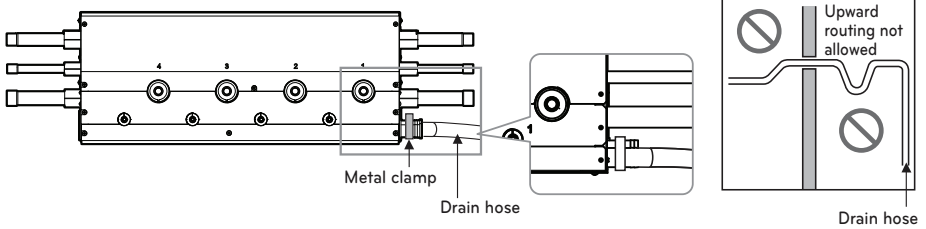

Drain test

- 1 Fit the drain hose(field supply-ID25.4) into the supplementary drain hole.
- 2 Try adding water through the supplementary drain hole.
- 3 Check for leaks in the drain hose.

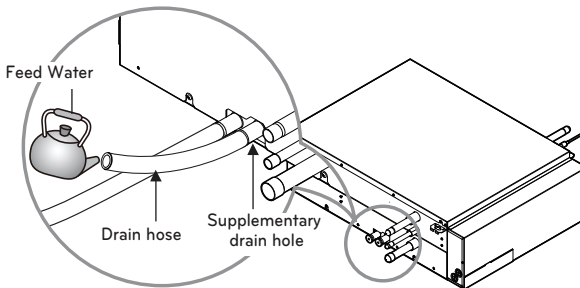

- 4 If there is no leakage, remove the drain hose and plug the cap through the supplementary drain hole.

Insulation

Insulate the connected pipes completely (all thermal insulation must comply with local requirement)

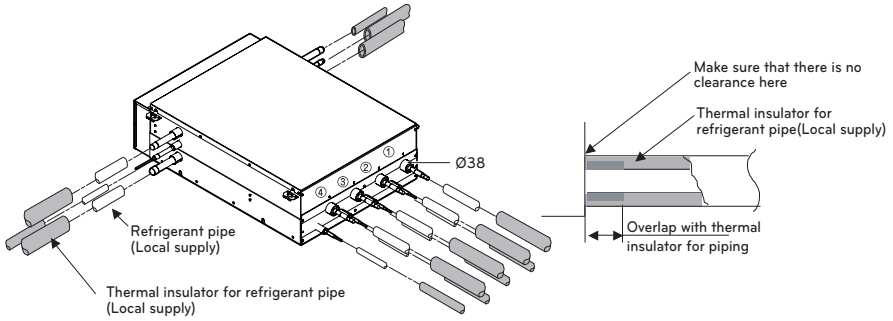

! CAUTION

Insulate completely unconnected pipes as shown in the Figure.

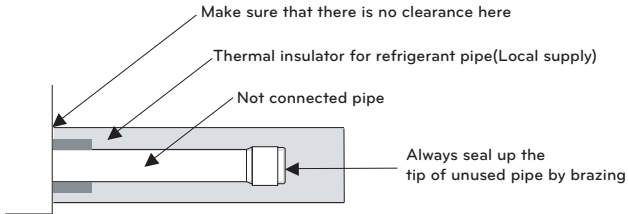



Plumbing materials and storage methods

Pipe must be able to obtain the specified thickness and should be used with low impurities. Also when handling storage, pipe must be careful to prevent a fracture, deformity and wound. Should not be mixed with contaminations such as dust, moisture.



Refrigerant piping on three principles

	Drying	Cleanliness	Airtight
	Should be no moisture inside	No dust inside.	There is no refrigerant leakage
Items			
Cause failure	<ul style="list-style-type: none"> - Significant hydrolysis of refrigerant oil - Degradation of refrigerant oil - Poor insulation of the compressor - Do not cold and warm - Clogging of EEV, Capillary 	<ul style="list-style-type: none"> - Degradation of refrigerant oil - Poor insulation of the compressor - Do not cold and warm - Clogging of EEV, Capillary 	<ul style="list-style-type: none"> - Gas shortages - Degradation of refrigerant oil - Poor insulation of the compressor - Do not cold and warm
Countermeasure	<ul style="list-style-type: none"> - No moisture in the pipe - Until the connection is completed, the plumbing pipe entrance should be strictly controlled. - Stop plumbing at rainy day. - Pipe entrance should be taken side or bottom. - When removal burr after cutting pipe, pipe entrance should be taken down. - Pipe entrance should be fitted cap when pass through the walls. 	<ul style="list-style-type: none"> - No dust in the pipe. - Until the connection is completed, the plumbing pipe entrance should be strictly controlled. - Pipe entrance should be taken side or bottom. - When removal burr after cutting pipe, pipe entrance should be taken down. - Pipe entrance should be fitted cap when pass through the walls. 	<ul style="list-style-type: none"> - Airtightness test should be. - Brazing operations to comply with standards. - Flare to comply with standards. - Flange connections to comply with standards.

Wiring Connection

Connect the wires to the terminals on the control board individually according to the outdoor unit connection.

- Ensure that the color of the wires of outdoor unit and the HR terminal No. are the same as those of HR Unit respectively.
- All communication and power wiring must be connected to the terminals using connectors certified or recognized according to UL and CSA standard.

* For the Multi-V, the communication line must be connected to the Master Outdoor Unit.

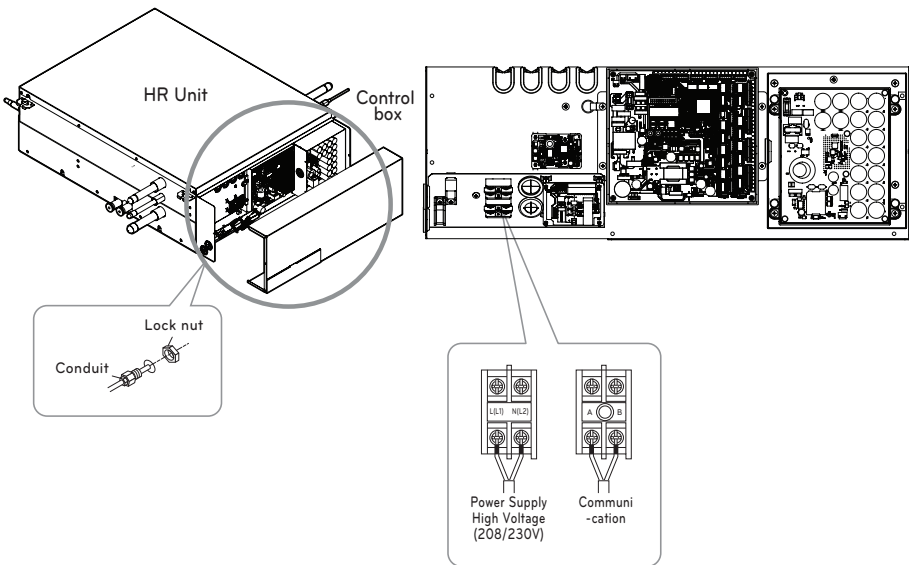
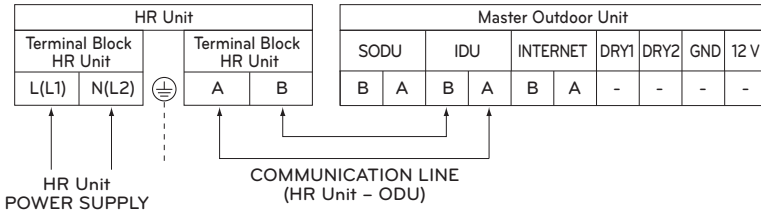

! WARNING

Loose wiring may cause the terminal to overheat or result in unit malfunction. A fire hazard may also exist.

Therefore, be sure all wiring is tightly connected.

Make sure that the screws of the terminal are free from looseness.

Electric Characteristics

- Recommended circuit breaker is ELCB
- MFA is used to select the circuit breaker and ground fault circuit interrupter

ELCB : Earth Leakage Circuit Breaker
MFA : Maximum Fuse Amperes(A)

⚠ CAUTION

The power and communication connecting cable between the outdoor and indoor units must comply with the following specifications: NRTL Recognized (for example, UL or ETL recognized and CSA certified).

AWG 18 is the minimum recommended wire size, however, the selected conductors must comply with local codes and be suitable for installation in wet locations.

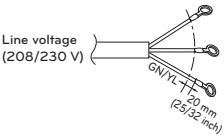
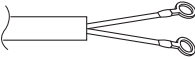
Power supply cable	Communication cable
 <p>Line voltage (208/230 V)</p> <p>G/N/PE 20 mm (25/32 inch)</p>	

If the supply cord is damaged, it must be replaced by a special cord or assembly available from the manufacturer of its service agent.

⚠ WARNING

Loose wiring may cause the terminal to overheat or result in unit malfunction. A fire hazard may also exist. Therefore, be sure all wiring is tightly connected.

⚠ WARNING

Make sure that the screws of the terminal are free from looseness.

Wiring of main power supply and equipment capacity

- Use a separate power supply for the Outdoor Unit and Indoor Unit.
- Bear in mind ambient conditions (ambient temperature, direct sunlight, rain water, etc.) when proceeding with the wiring and connections.
- The cable size is the minimum value for metal conduit wiring. The power cord size should be 1 rank thicker taking into account the line voltage drops. Make sure the power-supply voltage does not drop more than 10 %.
- Specific wiring requirements should adhere to the wiring regulations of the region.
- Power supply cords of parts of appliances for outdoor use should not be lighter than polychloroprene sheathed flexible cord.
- Don't install an individual switch or electrical outlet to disconnect each of indoor unit separately from the power supply.

The thickness of Minimum wire (mm ² [inch ²])			Leakage circuit breaker (4P ELCB)
Main power wire	Branch wire	Ground wire	
2.5~16 [3.875 × 10 ⁻³ ~ 2.48 × 10 ⁻²]	-	2.5~4 [3.875 × 10 ⁻³ ~ 6.2 × 10 ⁻³]	Below 20~60 A 100 mA 0.1 sec

* The above standard is CV wire standard.

* Please use the 3-phases 4-wires quadrupole Leakage circuit breaker of circuit breaker.

WARNING

- Follow ordinance of your governmental organization for technical standard related to electrical equipment, wiring regulations and guidance of each electric power company.
- Make sure to use specified cables for connections so that no external force is imparted to terminal connections. If connections are not fixed firmly, it may cause heating or fire.
- Make sure to use the appropriate type of over current protection switch. Note that generated over current may include some amount of direct current.

CAUTION

- Some installation site may require attachment of an earth leakage breaker. If no earth leakage breaker is installed, it may cause an electric shock.
- Do not use anything other than breaker and fuse with correct capacity. Using fuse and wire or copper wire with too large capacity may cause a malfunction of unit or fire.

Nitrogen substitution method

Welding, as when heating without nitrogen substitution a large amount of the oxide film is formed on the internal piping.

The oxide film is caused by clogging EEV, Capillary, oil hole of accumulator and suction hole of oil pump in compressor.

It prevents normal operation of the compressor.

In order to avoid this problem, Welding should be done after replacing air by nitrogen gas.

When welding plumbing pipe, the work is required.

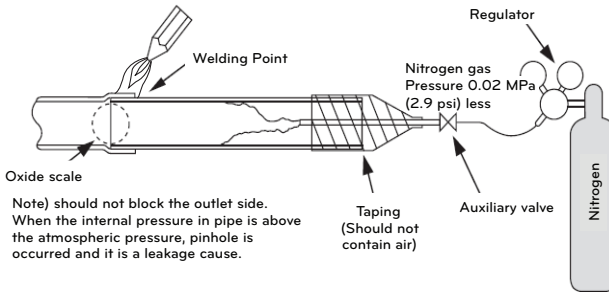

CAUTION



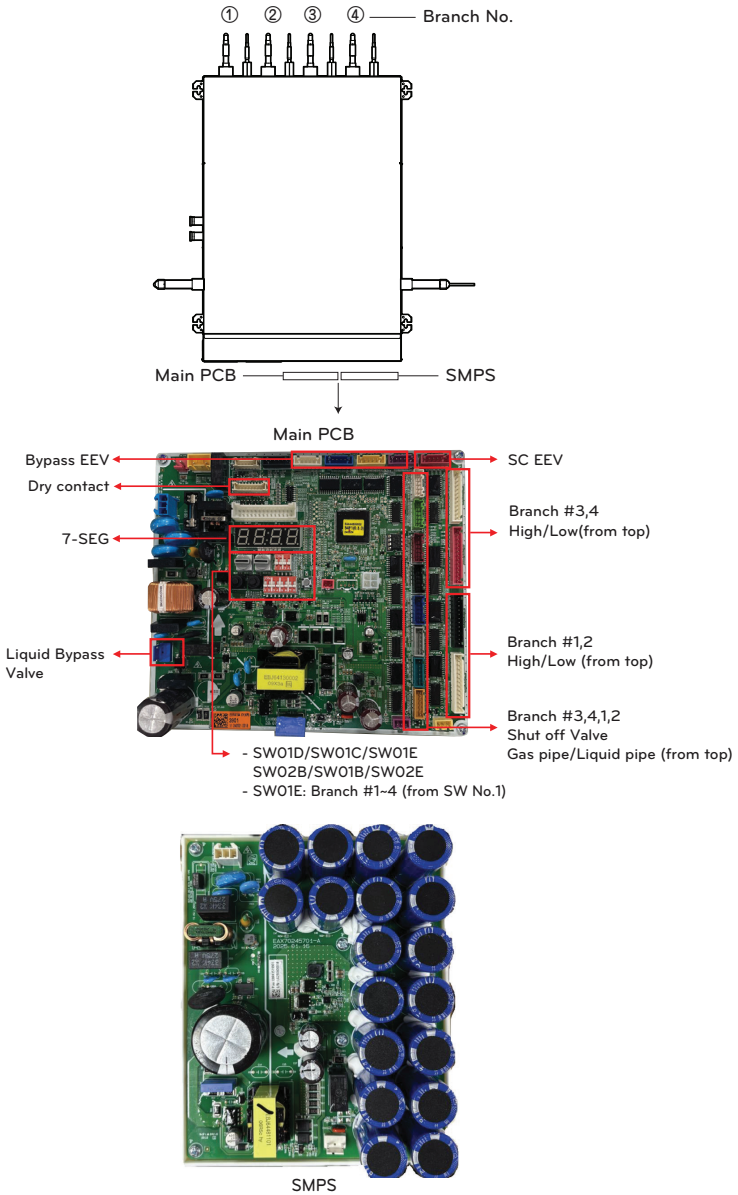

- Always use the nitrogen.
(not use oxygen, carbon dioxide, and a Chevron gas)
Please use the following nitrogen pressure 0.02 MPa (2.9 psi)
 - **Oxygen:** Promotes oxidative degradation of refrigerant oil.
Because it is flammable, it is strictly prohibited to use.
 - **Carbon dioxide:** Degrade the drying characteristics of gas
 - **Chevron Gas:** Toxic gas occurs when exposed to direct flame
- Always use a pressure reducing valve.
- Please do not use commercially available antioxidant.
The residual material seems to be the oxide scale is observed.
In fact, due to the organic acids generated by oxidation of the alcohol contained in the anti-oxidants, ants nest corrosion occurs. (Causes of organic acid → alcohol + copper + water + temperature)

HR Unit PCB



* Number from left in sequence for less-than-4 branch model.

Setup the switch of HR Unit

SW		Function	
DIP SW		SW02E (8 pin DIP SW)	<ul style="list-style-type: none"> - Selection of the method for pipe detection - Selection of Master/Slave Main PCB - Setting the Zoning Control - Selection of the No. of connected branches
		SW01E (4 pin DIP SW)	<ul style="list-style-type: none"> - Selection of the valve to address Auto addressing of zoning valves
Rotary SW		SW01D (Left)	<ul style="list-style-type: none"> - Selection of the Valve Group Control
		SW01C (Right)	<ul style="list-style-type: none"> - Manual addressing of zoning indoor units - Setting to address HR units
Push SW		SW02B (Left)	<ul style="list-style-type: none"> - Increase in the digit of 10
		SW01B (Right)	<ul style="list-style-type: none"> - Increase in the digit of 1

Main function of SW02E



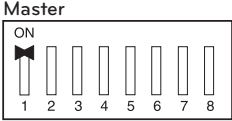

ON S/W	Selection	
No.1	Method for pipe detection of an HR Unit (Auto/Manual)	
No.2	No. of connected branches	
No.3		
No.4		
No.5	Master/Slave (Main PCB) Setting	
No.6	EEPROM factory initialization (4, 5, 6)	
No.7	Use only in factory production (preset to "OFF")	Zoning setting ("ON")
No.8	Use only in factory production (preset to "OFF")	

1 Selection of the method for pipe detection of an HR unit (Auto/Manual)





Auto	Manual
<p>Switch No.1 Off</p> 	<p>Switch No.1 On</p> 

* Master Only

2 Setting the zoning control

	SW02E setting	SW01E setting
Normal control	<p>* Master Only</p> 	 <p>SW01E</p>
Zoning control	<p>* Master Only</p> 	<p>Master</p>  <p>SW01E</p> <p>Turn the DIP switch of the zoning branch on. EX) Branch 1,2 are zoning control.</p>

3 Selection of the No. of connected branches

1 branch Connected		3 branches Connected	
2 branches Connected		4 branches Connected	

* Master Only

! WARNING

If you want to use a "Model" for "No. of using branch(es)" HR Unit after closing the "Closing pipe No.", set the DIP switch for "No. of using branch(es)" HR Unit.

EX) If you want to use a type of 4 port HR Unit for 2 branches HR Unit after closing the 3~4th pipes, set the DIP switch for 2 branches HR Unit

Main function of SW01D

1 Selection of the Valve Group Control

NOTE

Use the Valve Group Control when 2 branches are connected with only 1 indoor unit which has higher capacity than 61 kBTU.

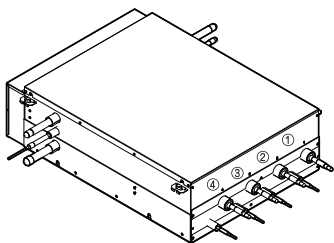

Valve Group	SW01D Setting
Not control	0
No. 1,2 Valve Control	1
No. 2,3 Valve Control	2
No. 3,4 Valve Control	3
No. 1,2 / 3,4 Valve Control	7

* Master Only

NOTE

If the large capacity indoor units are installed, below Y branch pipe should be used.

Y branch pipe

[Unit : mm]

Models	Gas pipe	Liquid pipe
ARBLN01621		
ARBLN03321		

SW01C (Rotary S/W for addressing HR unit)

Must be set to '0' when installing only one HR unit.

When installing multiple HR units, address the HR units with sequentially increasing numbers starting from '0'.

Maximum 16 HR Units can be installed.

Ex) Installation of 3 HR units

* Master Only

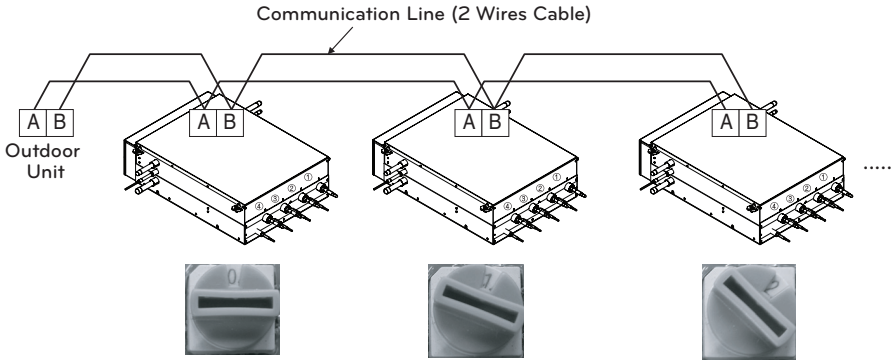





HR Unit No.	SW01C No.	HR Unit No.	SW01C No.
1	0	9	8
2	1	10	9
3	2	11	A
4	3	12	B
5	4	13	C
6	5	14	D
7	6	15	E
8	7	16	F

* About more detailed field wiring, please refer to the outdoor unit installation manual.

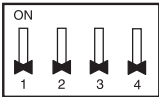
SW01B/SW01C/SW01E/SW02B (DIP S/W and push S/W for Manual pipe detection)

- Set the address of the valve of the HR unit to the central control address of the connected indoor unit.
- SW01E: selection of the valve to address
SW02B: increase in the digit of 10 of valve address
SW01B: increase in the last digit of valve address
SW01C: Manual addressing of zoning indoor units (use for Zoning setting)
- Prerequisite for Manual pipe detection : Central control address of each indoor unit must be preset differently at its wired remote control.

	S/W No.	Setup
 SW01E	No.1	Manual addressing of valve #1 (Master)
	No.2	Manual addressing of valve #2 (Master)
	No.3	Manual addressing of valve #3 (Master)
	No.4	Manual addressing of valve #4 (Master)
 SW02B	SW02B	Increase in the digit of 10 of valve address
 SW01B	SW01B	Increase in the last digit of valve address
* Use for Zoning setting  SW01C	SW01C	Manual addressing of zoning indoor units

1 Normal setting (Non-Zoning setting)

Ex) Manual pipe detection of Valve #1, 2.

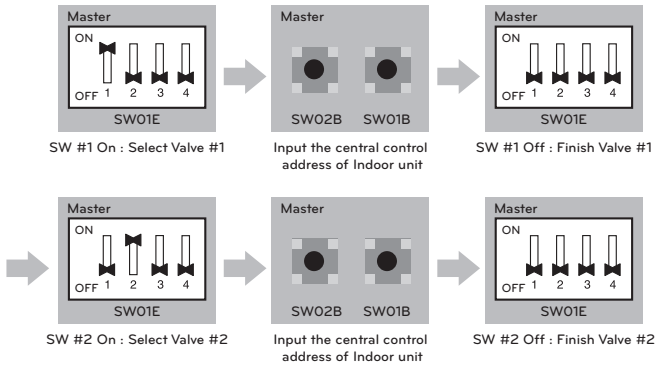

2 Zoning setting

NOTE

Use the Zoning Control when install two or more indoor units at 1 branch of HR Unit. The indoor units controlled by Zoning Control can be selected collectively as the cooling/heating mode.

Ex) Manual pipe detection of Valve #1 with three zoning indoor units, #2 without zoning unit.

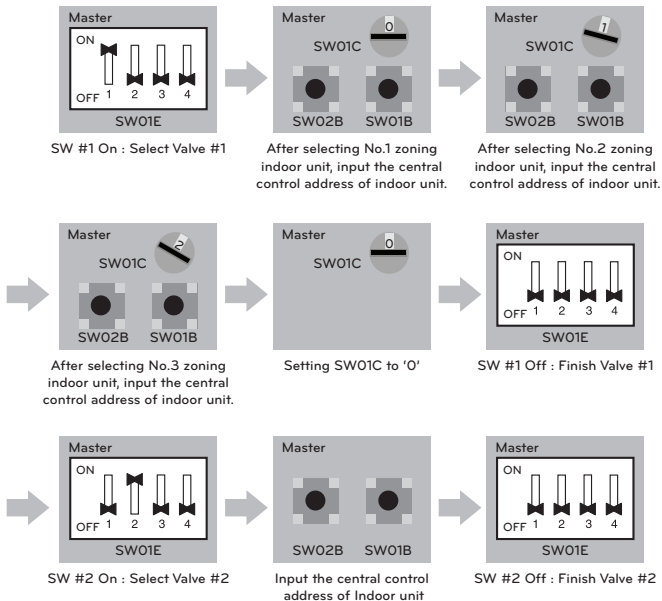

COIL EXCHANGING METHOD

- 1 Remove the 2 securing screws.
Remove the cover by pulling on the bottom of the cover and lifting up.
- 2 Remove the 6 securing screws.
Lift up and pull on the cover.

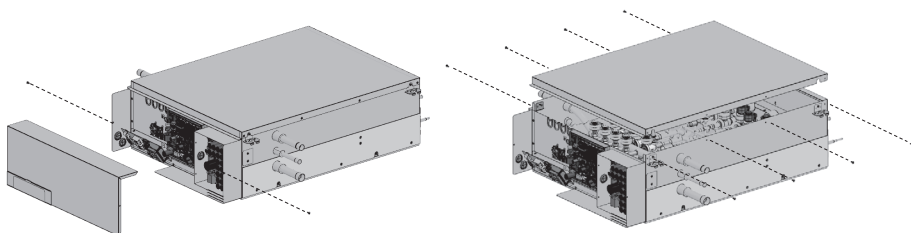

- 3 Exchange the coil.

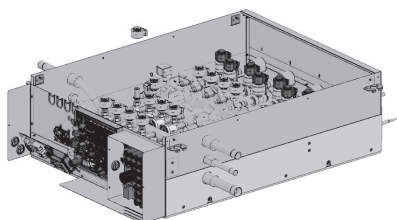

NOTE

Be sure that system power off before exchanging the coil.
Check the position of the valve coil with the label attached on the cover inside when abnormal noise is heard loudly during operation.

Position label of the valve coil of a type of 4 port HR unit

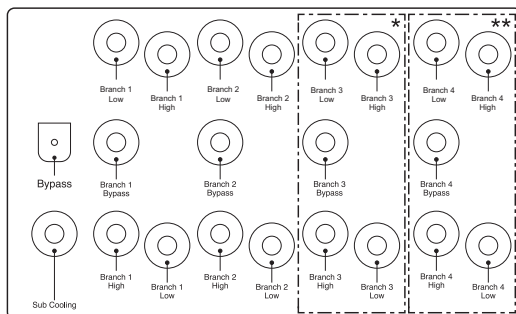

*: Not applied for models with 2 branches

** : Not applied for models with 2 and 3 branches

JOINT METHOD OF HR UNIT

Joint Method is required when use indoor unit that exceed 61 kBtu is installed. In Joint Method, two neighboring outlets of one HR unit are linked by Y branch pipe and connected to one indoor unit.

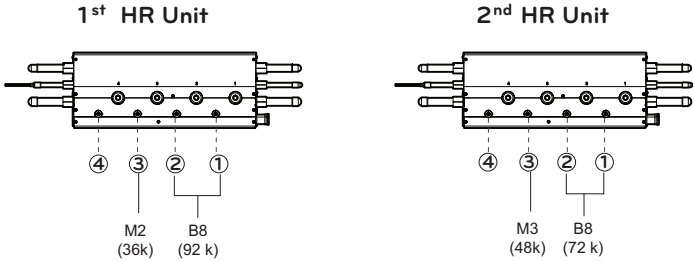

NOTE

1. A connection to un-neighboring pipes is forbidden. Do not link more than 2 outlets.

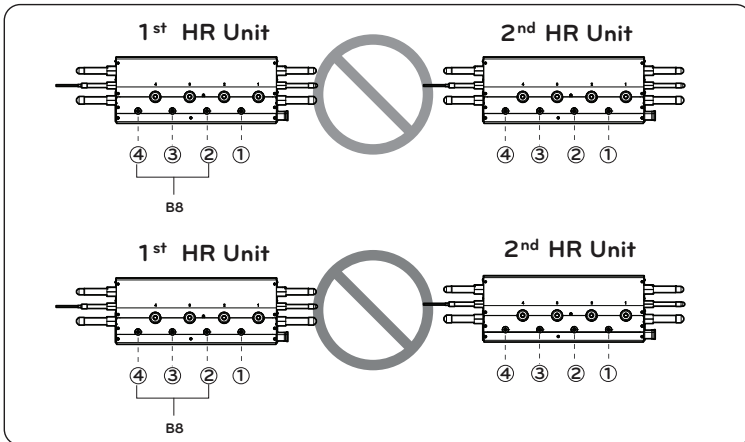

2. The B8 unit, which has the largest capacity, must be connected to the 1st and 2nd outlets of the 1st HR unit. Other B8 units can be connected to any two neighboring outlets within one HR unit.

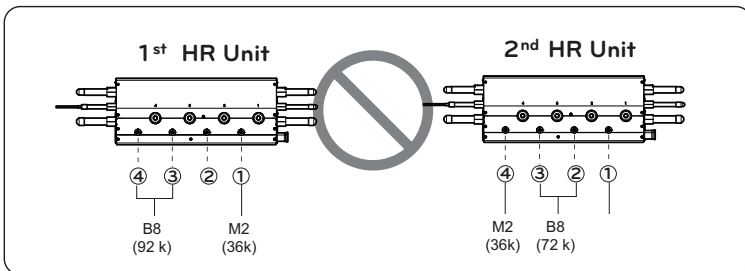



US	Please call the installing contractor of your product, as warranty service will be provided by them.
CANADA	Service call Number # : (888) LG Canada, (888) 542-2623 Numéro pour les appels de service : LG Canada, 1-888-542-2623