



Model RB-122-E Conductance Type Low Water Cut-Offs For Residential and Commercial Hot Water Boilers

Requires 120 VAC power supply and can switch 120 VAC
or 24 VAC burner control circuits

OPERATION

The Model RB-122-E Low Water Cut-Off is specifically designed to provide burner cut-off if there is an unsafe water loss, which can result from a broken or leaking radiator or pipe, or a cracked section in the boiler.

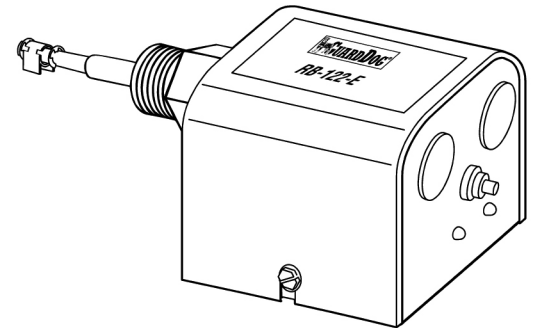

WARNING



- Before using this product read and understand instructions.
- Save these instructions for future reference
- All work must be performed by qualified personnel trained in the proper application, installation, and maintenance of HVSC systems in accordance with all applicable codes and ordinances.
- Boiler manufacturer schematics should always be followed. In the event that the boiler manufacturer's schematic does not exist, or is not available from the boiler manufacturer, refer to the schematics provided in this document.
- To prevent serious burns, the boiler must be cooled to 80°F (27°C) and the pressure must be 0 psi (0 bar) before servicing.
- To prevent dry fire, which could cause a fire, there must be a 2" (51mm) minimum width in the boiler section or 1¼" (32mm) pipe inner diameter for probe installation and operation
- The probe control must be connected in series with all other boiler operating and safety controls.
- We recommend that secondary (redundant) low water cut-off controls be installed on all steam boilers with heat input greater than 400,000 BTU/hour or operating above 15 psi of steam pressure. At least two controls should be connected in series with the burner control circuit to provide safety redundancy protection should the boiler experience a low-water condition. Moreover, at each annual outage, the low water cut-offs should be dismantled, inspected, cleaned, and checked for proper calibration and performance.
- California Proposition 65 warning! This product contains chemicals known to the state of California to cause cancer and birth defects or other reproductive harm.
- Previous controls should never be installed on a new system. Always install new controls on a new boiler or system.



Failure to follow this warning could cause property damage, personal injury or death.

CAUTION:

- A more frequent replacement interval may be necessary based on the condition of the unit at time of inspection. McDonnell & Miller's warranty is one (1) year from date of installation or two (2) years from the date of manufacture.

SPECIFICATIONS

Temperature:

Storage: -40°F to 120°F (-40°C to 49°C)
 Ambient: 32°F to 120°F (0°C to 49°C)

Humidity: 85% (non-condensing)

Maximum Water Pressure: 160 psi (11 kg/cm²)

Maximum Water Temperature: 250°F (121°C)

Features:

- Automatic reset after power outage
- Test button to verify operation
- Short probe for installation in 1-1/4" or larger pipe
- Self-cleaning probe

Electrical Contact Ratings

Voltage	Pump Circuit Rating (Amperes)		Pilot Duty
	Full Load	Locked Rotor	
120 VAC	5.8	34.8	125 VA at
240 VAC	2.9	17.4	120 or 240 VAC

Control Voltage: 120VAC

HZ: 50/60

Power Consumption: 3.1 VA

Electrical Enclosure Rating: NEMA 1 General Purpose

Probe Sensitivity: 20,000 ohms

Conductive liquid required
 (water/glycol mixtures up to 50% concentration
 may be used)

INSTALLATION –

STEP 1 - Where to Install the Probe Control

Determine where to install the probe control based on the following requirements:

a. If tappings are provided on the boiler, install the probe control in one that is above the minimum safe water level, as specified by the boiler manufacturer. If no specified mini-

imum safe water level is designated, contact the boiler manufacturer.

b. If no tapping is provided on the boiler, install the probe control in a header or riser pipe above the boiler. Refer to the Typical Installation Diagrams below.

IMPORTANT: Avoid installing where water or air may be trapped.

TYPICAL INSTALLATION DIAGRAMS

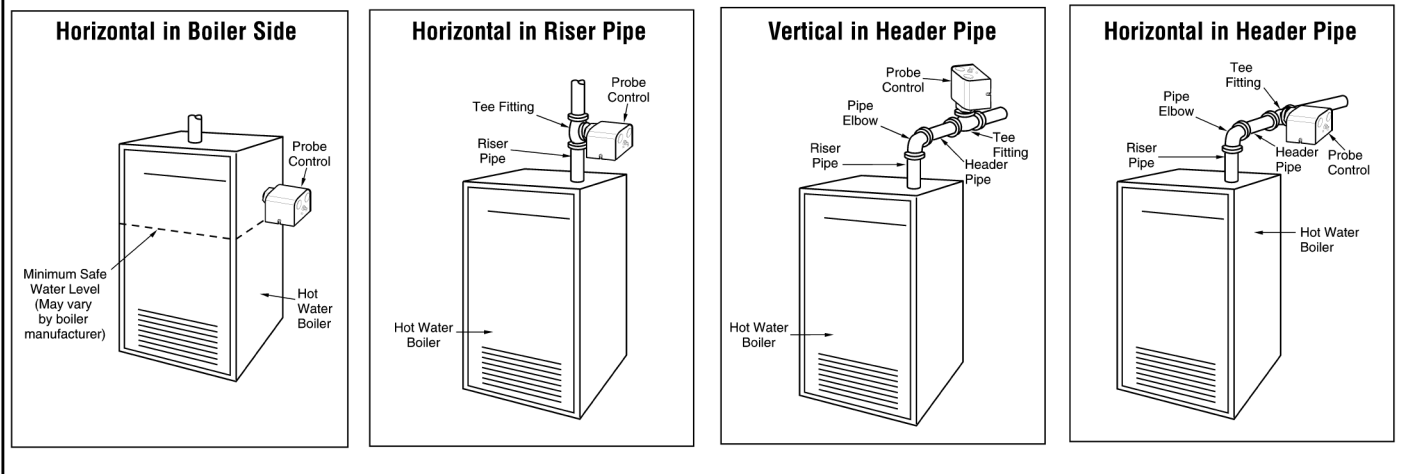

STEP 2 - Installation of the Low Water Cut-Off

Based on the following criteria locate a suitable position for the probe (A):

1. Make sure that the end and sides of the probe are at least 1/4" (6.4 mm) from all internal metal surfaces to prevent shorting of the probe to ground.
2. Make sure that the probe extends into the boiler cavity in order to sense the water.
3. The probe (A) must be installed above the minimum safe water level (B) as determined by the boiler manufacturer.

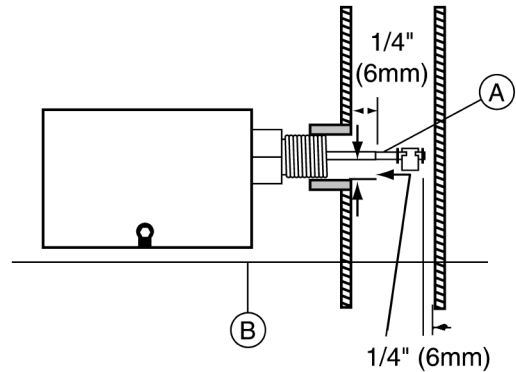

- a. Apply pipe sealing compound on the probe threads (A).

IMPORTANT: Do not use PTFE tape. Only use pipe sealant.

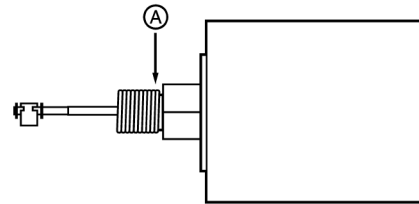

- b. Insert the probe portion (B) of the probe control into the 3/4" NPT boiler coupling (C), above the **minimum safe water level, as specified by the boiler manufacturer.**

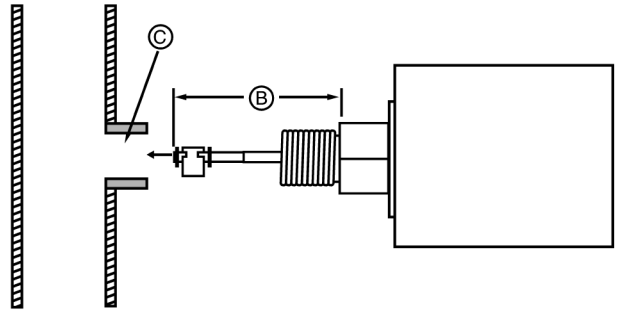

- c. Using a 1-3/8" (35mm) open end wrench tighten the brass hex adapter (F) to 47 ft•lb (64 N•m).

IMPORTANT: Do not turn the housing cover to tighten the probe control or damage will result.

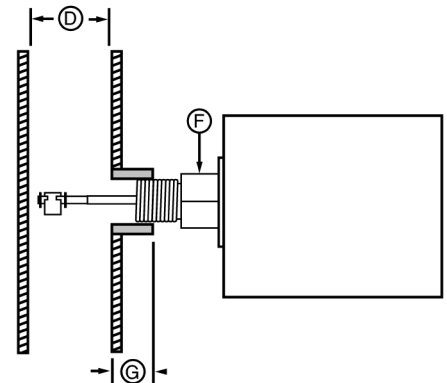
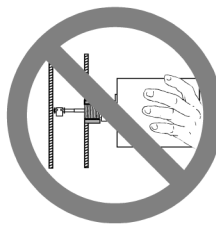

WARNING



To prevent dry fire, which could cause a fire there must be a 2" (51mm) minimum width in the boiler section (D) and the 3/4" (20mm) NPT coupling must be 1/2" (12.7mm) in length (G) for probe installation and operation.

Failure to follow this warning could cause property damage, personal injury, or death.

STEP 3 - Electrical Installation

WARNING



- To prevent electrical shock, turn off the electrical power before making electrical connections.
- This low water cut-off must be installed in series with all other limit and operating controls installed on the boiler. After installation, check for proper operation of all of the limit and operating controls, before leaving the site.
- All work must be performed by qualified personnel trained in the proper application, installation, and maintenance of plumbing, steam, and electrical equipment and/or systems in accordance with all applicable codes and ordinances.



Failure to follow this warning could cause electrical shock, an explosion and/or fire, which could result in property damage, personal injury or death.

IMPORTANT

Boiler manufacturer schematics should always be followed. In the event that the boiler manufacturer's schematic does not exist, or is not available from the boiler manufacturer, refer to the schematics provided in this document.

WARNING



To prevent an electrical fire or equipment damage, electrical wiring must have a rating of 167°F (75°C) if the liquid's temperature exceeds 180°F (82°C). Failure to follow this warning could cause property damage, personal injury or death.

- a. Loosen, but do not remove the (2) two screws (AA) from the housing cover (BB).

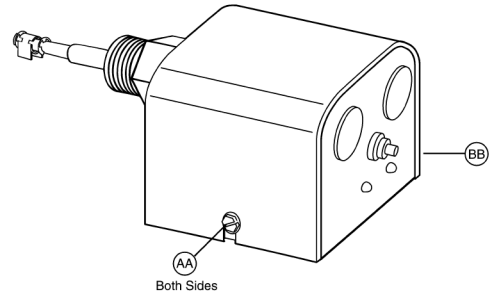

- b. Remove the housing cover (BB).

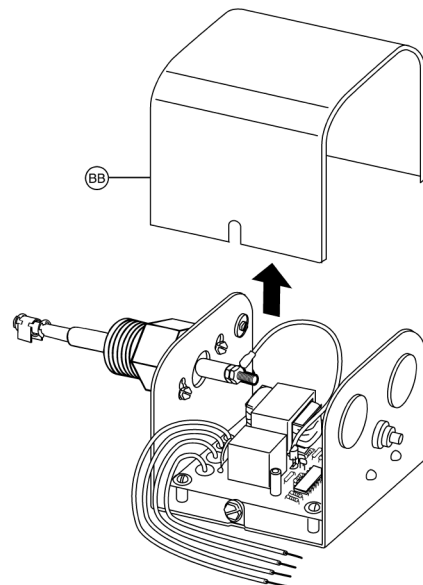

(Follow the procedure below or on page 6, as appropriate for your application)

Option 1:

This diagram can be used if you are wiring the RB-122-E to interrupt ALL power to the boiler when a low water condition occurs.

The control can be wired this way if the total amp load of the boiler does not exceed 5.8 amps @ 120 VAC when the boiler is running. If the total amp load exceeds 5.8 amps @ 120 VAC when the boiler is running, the control should be wired as shown in Option 2.

Using the boiler Service Switch as a reference, connect wires as shown. Use wire nuts (not furnished) to complete connections.

- Connect **White (N)** wire as shown to 120VAC circuit neutral wire.
- Connect **Black (H)** wire and **Yellow (C)** wire as shown to 120VAC circuit hot wire from Service Switch.
- Connect **Yellow (B)** wire as shown to L1 connection on boiler control panel.

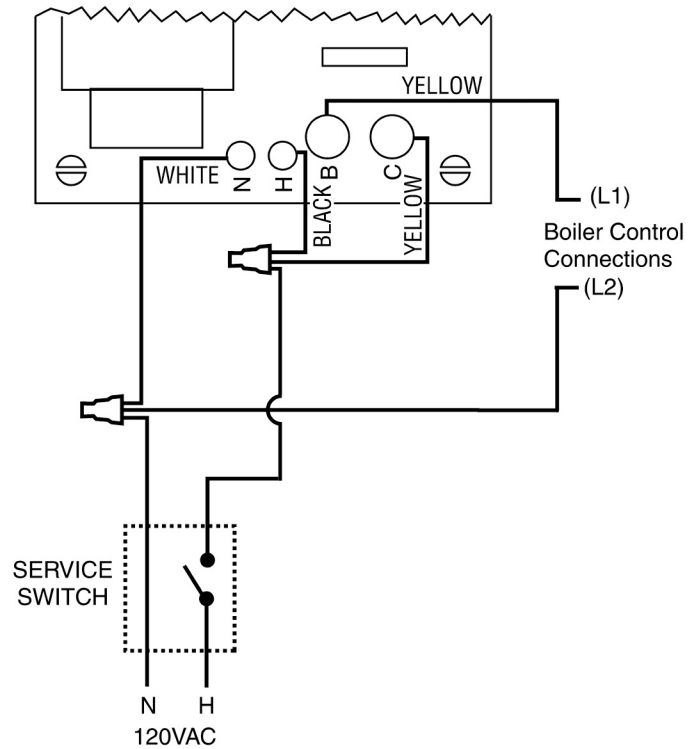

Proceed to page 7, Step 4 - Testing.

Option 2:

This diagram can be used if you are wiring the RB-122-E to interrupt power to the boiler burner or safety circuit only.

The control can be wired this way to interrupt either a 24 VAC or 120 VAC burner control safety circuit. Consult boiler manufacturers wiring diagrams to identify the safety circuit and recommended location to connect the **Yellow** wires.

Using the boiler Service Switch as a reference, connect wires as shown. Use wire nuts (not furnished) to complete connections.

- Connect **White (N)** wire as shown to 120VAC circuit neutral wire.
- Connect **Black (H)** wire as shown to 120VAC circuit hot wire.
- Locate Boiler Burner Safety Circuit and connect **Yellow (B)** and **Yellow (C)** wires as shown to interrupt circuit.

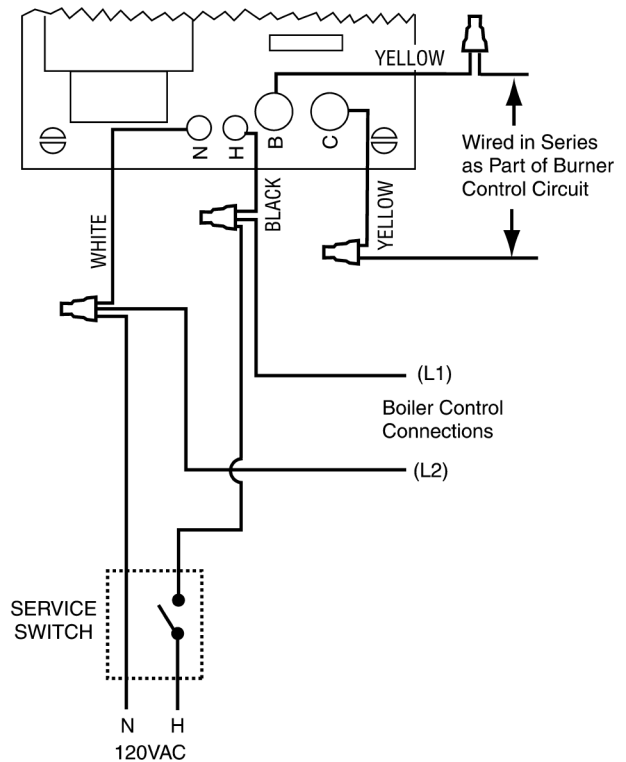

- c. Place the probe control's housing cover (BB) over the housing (M).

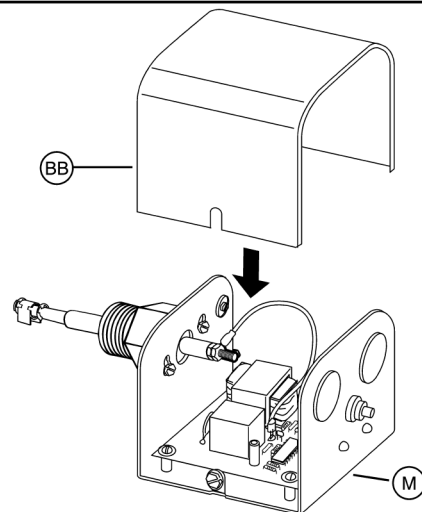

- d. Tighten the (2) screws (AA).

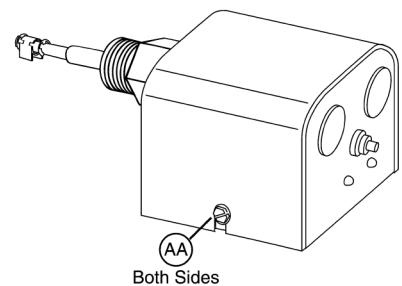

STEP 4 - Testing

Start-Up

- a. **Before filling the system**, turn on the electric power to the boiler. The low water cut-off's green "Power On" LED should be illuminated. With the room thermostat set on "heat," confirm that the burner **will not** operate without water in the system. The low water cut-off's red LED should be illuminated.

NOTE: The burner will come on briefly (1 second or less) and then shut off to verify proper operation.

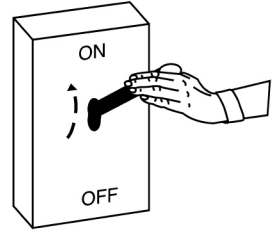

- b. Fill the system with water. The low water cut-off's red LED should shut off. Confirm that the burner and room thermostat are operating properly.
- c. Check for proper operation of all of the limit and operating controls, before leaving the site.
- d. Check the threaded connection of the low water cut-off for leakage. Tighten, if necessary.

Testing Control Using "Test Button"

Pressing the "Test Button" interrupts the probe circuit which simulates water off the probe.

- a. Press and hold "test button" while burner is running.
- b. The burner should turn OFF and red light turn ON if burner circuit is wired correctly.
- c. Release the test button and the red light should turn off and the burner should turn on provided that the boiler water is in contact with the probe.

MAINTENANCE

SCHEDULE:

- Test the low water cut-off annually or more frequently.
- Remove and inspect the self-cleaning probe every 5 years.
- Replace probe every 10 years.
- Replace the low water cut-off every 15 years.

TROUBLESHOOTING

Problem:

Refer to Step 2 on page 3.

1. Failure to Operate

- a. **Cause:** No voltage is being supplied to the probe control.

Test: Using a voltage meter, verify that voltage is being sent to wire (H) and (N) of the probe control.

Solution: If no voltage is being supplied, make necessary electrical modifications.

If voltage is supplied to the probe control but not the probe, verify that the electrical wiring connections are correct according to the instructions, pages 4–8.

If these solutions do not resolve the problem, replace the probe control.

- b. **Cause:** The probe end is making contact with the boiler or pipe wall.

Test: Remove the probe control. Using a ruler, verify that a 2" (51mm) minimum width in the boiler section or 1¼" (32mm) pipe inner diameter is provided for probe installation and operation.

Solution: Install the probe control where a 2" (51mm) width in the boiler section or 1¼" (32mm) pipe inner diameter exists.

- c. **Cause:** PTFE tape was used on the probe.

Test: Remove the probe control and inspect probe threads.

Solution: Remove PTFE tape. Apply pipe sealing compound on the probe threads.

- d. **Cause:** Air Pocket Surrounding Probe.

Solution: Remove the probe control, purge air from the system by opening the water feed valve until water flows from the tapping. Reinstall the probe control and shut off the water feed valve.

- e. **Cause:** Other system electrical wiring and/or operating control problems.

Solution: Determine cause and resolve problems.

COMMERCIAL WARRANTY

Warranty. For goods sold to commercial buyers, Seller warrants the goods sold to Buyer hereunder (with the exception of membranes, seals, gaskets, elastomer materials, coatings and other "wear parts" or consumables all of which are not warranted except as otherwise provided in the quotation or sales form) will be (i) be built in accordance with the specifications referred to in the quotation or sales form, if such specifications are expressly made a part of this Agreement, and (ii) free from defects in material and workmanship for a period of one (1) year from the date of installation or two (2) years from the date of manufacture, whichever shall occur first, unless a longer period is specified in the product documentation (the "Warranty").

Except as otherwise required by law, Seller shall, at its option and at no cost to Buyer, either repair or replace any product which fails to conform with the Warranty provided Buyer gives written notice to Seller of any defects in material or workmanship within ten (10) days of the date when any defects or non-conformance are first manifest. Under either repair or replacement option, Seller shall not be obligated to remove or pay for the removal of the defective product or install or pay for the installation of the replaced or repaired product and Buyer shall be responsible for all other costs, including, but not limited to, service costs, shipping fees and expenses. Seller shall have sole discretion as to the method or means of repair or replacement. Buyer's failure to comply with Seller's repair or replacement directions shall terminate Seller's obligations under this Warranty and render the Warranty void. Any parts repaired or replaced under the Warranty are warranted only for the balance of the warranty period on the parts that were repaired or replaced. Seller shall have no warranty obligations to Buyer with respect to any product or parts of a product that have been: (a) repaired by third parties other than Seller or without Seller's written approval; (b) subject to misuse, misapplication, neglect, alteration, accident, or physical damage; (c) used in a manner contrary to Seller's instructions for installation, operation and maintenance; (d) damaged from ordinary wear and tear, corrosion, or chemical attack; (e) damaged due to abnormal conditions, vibration, failure to properly prime, or operation without flow; (f) damaged due to a defective power supply or improper electrical protection; or (g) damaged resulting from the use of accessory equipment not sold or approved by Seller. In any case of products not manufactured by Seller, there is no warranty from Seller; however, Seller will extend to Buyer any warranty received from Seller's supplier of such products.

THE FOREGOING WARRANTY IS EXCLUSIVE AND IN LIEU OF ANY AND ALL OTHER EXPRESS OR IMPLIED WARRANTIES, GUARANTEES, CONDITIONS OR TERMS OF WHATEVER NATURE RELATING TO THE GOODS PROVIDED HEREUNDER, INCLUDING WITHOUT LIMITATION ANY IMPLIED WARRANTIES OF MERCHANTABILITY AND FITNESS FOR A PARTICULAR PURPOSE, WHICH ARE HEREBY EXPRESSLY DISCLAIMED AND EXCLUDED. EXCEPT AS OTHERWISE REQUIRED BY LAW, BUYER'S EXCLUSIVE REMEDY AND SELLER'S AGGREGATE LIABILITY FOR BREACH OF ANY OF THE FOREGOING WARRANTIES ARE LIMITED TO REPAIRING OR REPLACING THE PRODUCT AND SHALL IN ALL CASES BE LIMITED TO THE AMOUNT PAID BY THE BUYER FOR THE DEFECTIVE PRODUCT. IN NO EVENT SHALL SELLER BE LIABLE FOR ANY OTHER FORM OF DAMAGES, WHETHER DIRECT, INDIRECT, LIQUIDATED, INCIDENTAL, CONSEQUENTIAL, PUNITIVE, EXEMPLARY OR SPECIAL DAMAGES, INCLUDING BUT NOT LIMITED TO LOSS OF PROFIT, LOSS OF ANTICIPATED SAVINGS OR REVENUE, LOSS OF INCOME, LOSS OF BUSINESS, LOSS OF PRODUCTION, LOSS OF OPPORTUNITY OR LOSS OF REPUTATION.

LIMITED CONSUMER WARRANTY

Warranty. For goods sold for personal, family or household purposes, Seller warrants the goods purchased hereunder (with the exception of membranes, seals, gaskets, elastomer materials, coatings and other "wear parts" or consumables all of which are not warranted except as otherwise provided in the quotation or sales form) will be free from defects in material and workmanship for a period of one (1) year from the date of installation or two (2) years from the product date code, whichever shall occur first, unless a longer period is provided by law or is specified in the product documentation (the "Warranty").

Except as otherwise required by law, Seller shall, at its option and at no cost to Buyer, either repair or replace any product which fails to conform with the Warranty provided Buyer gives written notice to Seller of any defects in material or workmanship within ten (10) days of the date when any defects or non-conformance are first manifest. Under either repair or replacement option, Seller shall not be obligated to remove or pay for the removal of the defective product or install or pay for the installation of the replaced or repaired product and Buyer shall be responsible for all other costs, including, but not limited to, service costs, shipping fees and expenses. Seller shall have sole discretion as to the method or means of repair or replacement. Buyer's failure to comply with Seller's repair or replacement directions shall terminate Seller's obligations under this Warranty and render this Warranty void. Any parts repaired or replaced under the Warranty are warranted only for the balance of the warranty period on the parts that were repaired or replaced. The Warranty is conditioned on Buyer giving written notice to Seller of any defects in material or workmanship of warranted goods within ten (10) days of the date when any defects are first manifest.

Seller shall have no warranty obligations to Buyer with respect to any product or parts of a product that have been: (a) repaired by third parties other than Seller or without Seller's written approval; (b) subject to misuse, misapplication, neglect, alteration, accident, or physical damage; (c) used in a manner contrary to Seller's instructions for installation, operation and maintenance; (d) damaged from ordinary wear and tear, corrosion, or chemical attack; (e) damaged due to abnormal conditions, vibration, failure to properly prime, or operation without flow; (f) damaged due to a defective power supply or improper electrical protection; or (g) damaged resulting from the use of accessory equipment not sold or approved by Seller. In any case of products not manufactured by Seller, there is no warranty from Seller; however, Seller will extend to Buyer any warranty received from Seller's supplier of such products.

THE FOREGOING WARRANTY IS PROVIDED IN PLACE OF ALL OTHER EXPRESS WARRANTIES. ALL IMPLIED WARRANTIES, INCLUDING BUT NOT LIMITED TO THE IMPLIED WARRANTIES OF MERCHANTABILITY AND FITNESS FOR A PARTICULAR PURPOSE, ARE LIMITED TO ONE (1) YEAR FROM THE DATE OF INSTALLATION OR TWO (2) YEARS FROM THE PRODUCT DATE CODE, WHICHEVER SHALL OCCUR FIRST. EXCEPT AS OTHERWISE REQUIRED BY LAW, BUYER'S EXCLUSIVE REMEDY AND SELLER'S AGGREGATE LIABILITY FOR BREACH OF ANY OF THE FOREGOING WARRANTIES ARE LIMITED TO REPAIRING OR REPLACING THE PRODUCT AND SHALL IN ALL CASES BE LIMITED TO THE AMOUNT PAID BY THE BUYER FOR THE DEFECTIVE PRODUCT. IN NO EVENT SHALL SELLER BE LIABLE FOR ANY OTHER FORM OF DAMAGES, WHETHER DIRECT, INDIRECT, LIQUIDATED, INCIDENTAL, CONSEQUENTIAL, PUNITIVE, EXEMPLARY OR SPECIAL DAMAGES, INCLUDING BUT NOT LIMITED TO LOSS OF PROFIT, LOSS OF ANTICIPATED SAVINGS OR REVENUE, LOSS OF INCOME, LOSS OF BUSINESS, LOSS OF PRODUCTION, LOSS OF OPPORTUNITY OR LOSS OF REPUTATION.

Some states do not allow limitations on how long an implied warranty lasts, so the above limitation may not apply to you. Some states do not allow the exclusion or limitation of incidental or consequential damages, so the above exclusions may not apply to you. This warranty gives you specific legal rights, and you may also have other rights which may vary from state to state.

To make a warranty claim, check first with the dealer from whom you purchased the product or call +1-847-966-3700 for the name and location of the nearest dealer providing warranty service.



Xylem Inc.
8200 N. Austin Avenue
Morton Grove, Illinois 60053
Phone: (847) 966-3700
Fax: (847) 965-8379
www.mcdonnellmiller.com

McDonnell & Miller is a trademark of Xylem Inc. or one of its subsidiaries.
© 2015 Xylem Inc. MM-238N July 2015 Part No. 210408

