



SERVICE PARTS LIST

MAIN BODY ASSEMBLIES & ACCESSORIES

BULLETIN NO.
54-07-2781

SPECIFY CATALOG NO. AND SERIAL NO. WHEN ORDERING PARTS		REVISED BULLETIN	DATE
M18™ DRAIN SNAKE WITH CABLE-DRIVE™ LOCKING FEED SYSTEM		54-07-2780	June 2021
CATALOG NO.	2772-20	SERIAL NUMBER	H81B
WIRING INSTRUCTION			

EXAMPLE:

00	0
----	---

 Component Parts (Small #) Are Included When Ordering The Assembly (Large #).

SERVICE TABLE OF CONTENTS	
Page 1	Main Body Assemblies
Page 2	Front Handle Assemblies
Page 3	Bucket Assemblies & Cable Accessories
Page 4	Grease

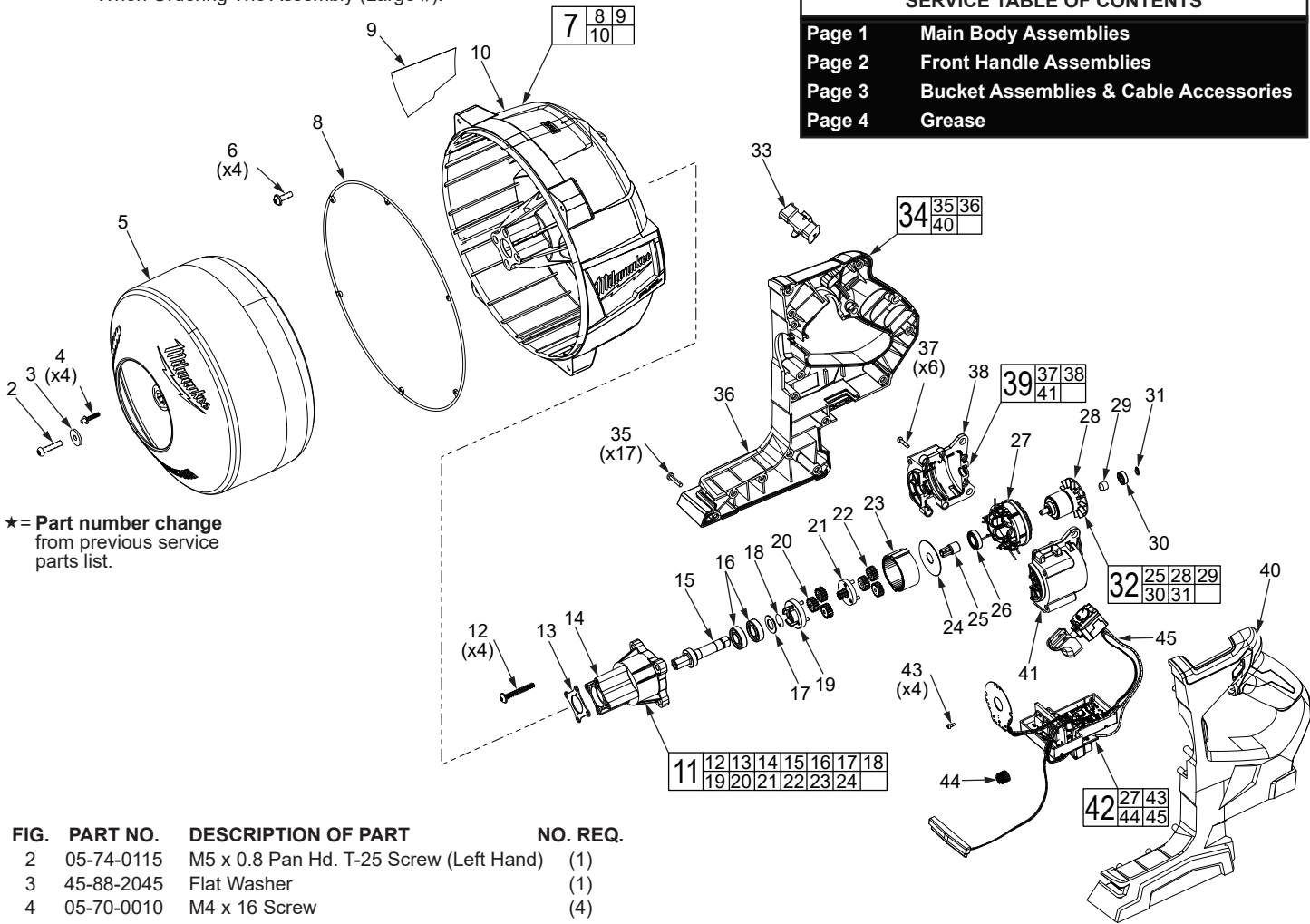

★ = Part number change from previous service parts list.

FIG.	PART NO.	DESCRIPTION OF PART	NO. REQ.
2	05-74-0115	M5 x 0.8 Pan Hd. T-25 Screw (Left Hand)	(1)
3	45-88-2045	Flat Washer	(1)
4	05-70-0010	M4 x 16 Screw	(4)
5	43-11-0020	Cable Drum	(1)
6	05-81-0060	M5 x 0.8 Screw	(4)
7	31-55-0012	Drum Shroud Assembly	(1)
8	43-44-0017	Seal Ring	(1)
9	12-20-0099	Service Nameplate	(1)
10	-----	Drum Shroud	(1)
11	14-30-0025	Gear Case Assembly	(1)
12	-----	M5 x 2 Screw	(4)
13	-----	Flat Washer	(1)
14	-----	Gear Case	(1)
15	-----	Output Shaft	(1)
16	-----	Ball Bearing	(2)
17	-----	Flat Washer	(1)
18	-----	Retaining Ring	(1)
19	-----	Carrier	(1)
20	-----	2nd Planet Gear	(3)
21	-----	Sun Gear	(1)
22	-----	1st Planet Gear	(3)
23	-----	Ring Gear	(1)
24	-----	Washer	(1)
25	-----	Motor Pinion	(1)
26	-----	Ball Bearing	(1)
27	-----	Motor Field	(1)
28	-----	Motor Armature	(1)

FIG.	PART NO.	DESCRIPTION OF PART	NO. REQ.
29	-----	Rear Bearing Washer	(1)
30	-----	Ball Bearing	(1)
31	-----	Retaining Ring	(1)
32	16-10-0030	Armature Assembly	(1)
33	42-42-0051	Forward/Reverse/Lock Off Shuttle	(1)
★ 34	14-34-0041	Housing Kit	(1)
35	-----	6-19 x 11/16" Pan Hd. Taptite T15 Screw	(17)
36	-----	Right Handle	(1)
37	-----	Screw	(6)
38	-----	Right Motor Cage	(1)
39	14-50-0033	Motor Field Assembly	(1)
40	-----	Left Handle	(1)
41	-----	Left Motor Cage	(1)
★ 42	22-74-0026	PCBA Assembly	(1)
43	-----	M2 x 1 Screw	(4)
44	-----	Latch Spring	(1)
45	-----	PCBA	(1)

FRONT HANDLE ASSEMBLIES

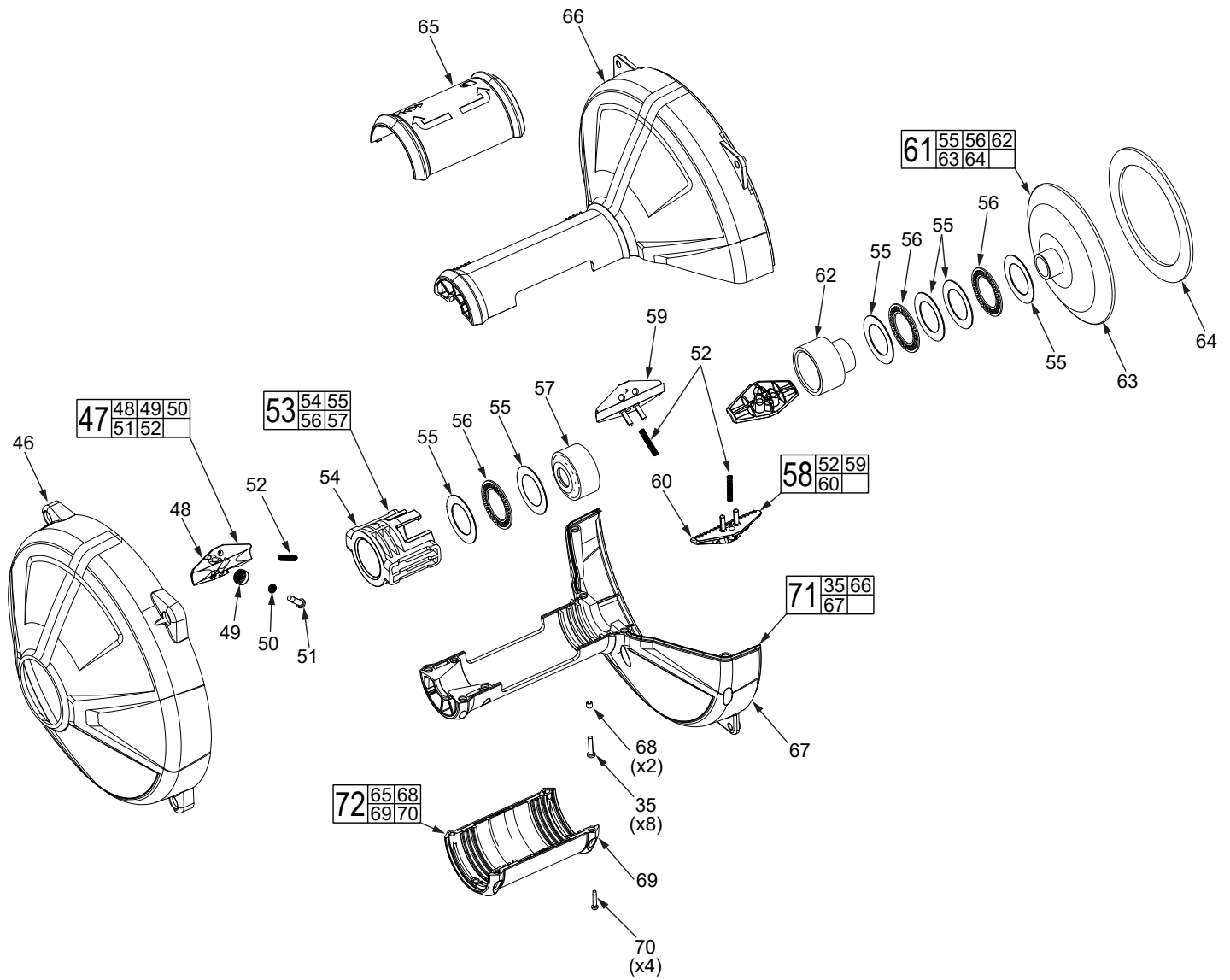
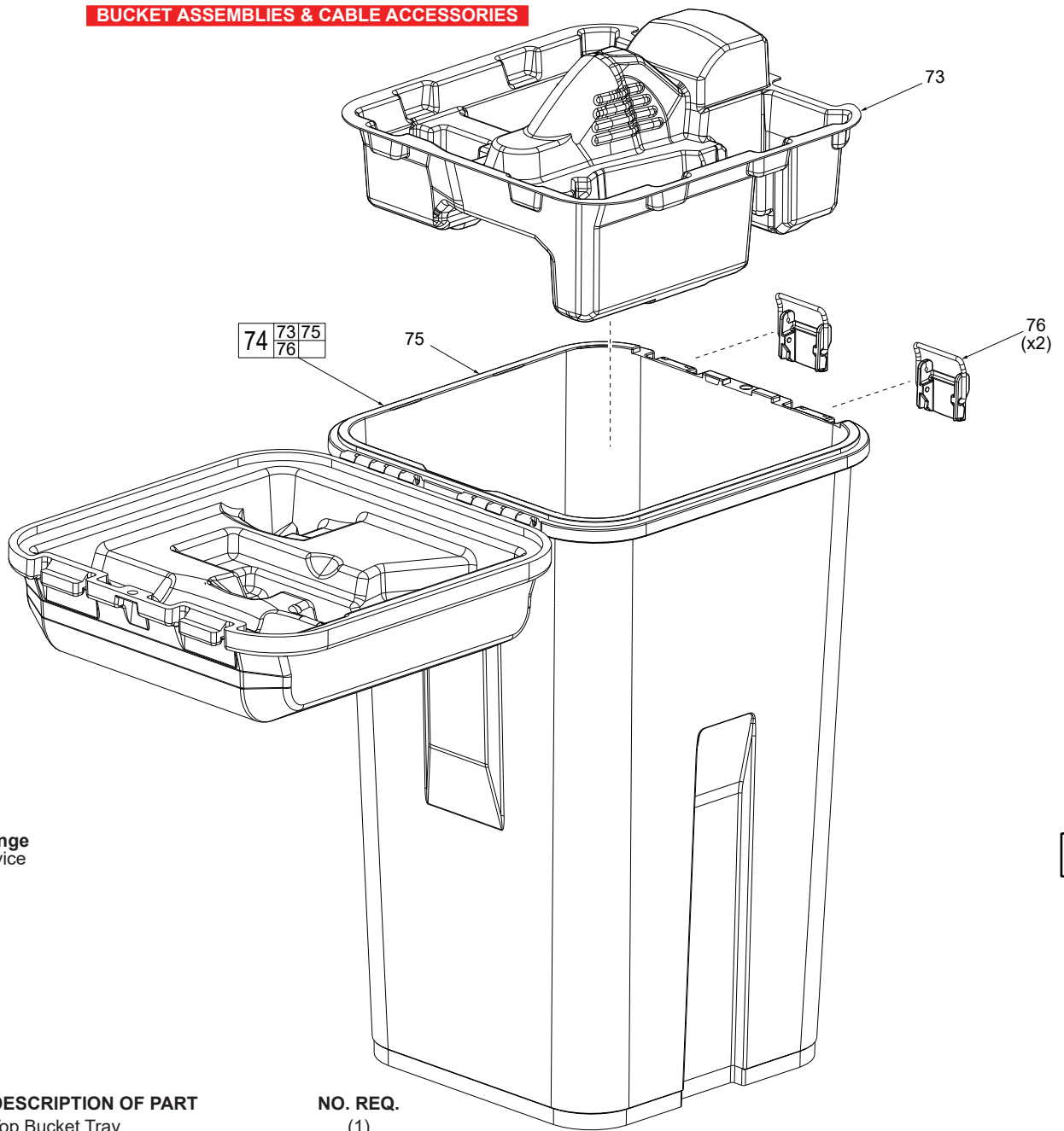

FIG.	PART NO.	DESCRIPTION OF PART	NO. REQ.
	35	6-19 x 11/16" Pan Hd. Taptite T15 Screw	(8)
	46	43-86-0016 Rubber Boot	(1)
	47	42-77-0075 Collet Kit (Set of 3)	(1)
	48	Collet	(3)
	49	Ball Bearing	(3)
	50	Flat Washer	(3)
	51	8-16 x 5/8" Pan Hd. ST T20 Screw	(3)
	52	Spring	(6)
	53	31-15-0056 Lock Slide Assembly	(1)
	54	Lock Slide	(1)
	55	Flat Washer	(6)
	56	Bearing	(3)
	57	Lock Slide Ramp	(1)
	58	42-77-0080 Lock Collet Kit	(1)
	59	Flat Spring Lock Collet	(1)

FIG.	PART NO.	DESCRIPTION OF PART	NO. REQ.
	60	Lock Collet	(2)
	61	42-77-0085 Cable Funnel Assembly	(1)
	62	Lock Collet Ramp	(1)
	63	Cable Funnel	(1)
	64	Gasket	(1)
	65	Twist Lock Upper Handle	(1)
	66	Left Shroud Cover	(1)
	67	Right Shroud Cover w/ Cover Seal	(1)
	68	Nut	(2)
	69	Twist Lock Lower Handle	(1)
	70	M3 x 16 Screw	(4)
	71	31-15-0070 Shroud Cover Kit	(1)
	72	31-15-0066 Twist Lock Kit	(1)

BUCKET ASSEMBLIES & CABLE ACCESSORIES



★ = Part number change from previous service parts list.

FIG.	PART NO.	DESCRIPTION OF PART	NO. REQ.
	73	31-40-0052 Top Bucket Tray	(1)
★	74	42-51-0036 Bucket Assembly	(1)
	75	----- Bucket	(1)
	76	44-20-1015 Latch	(2)

Cables & Attachment Head Accessories

--	48-53-2561	5/16" x 25' Inner Core Rust Resistant Bulb Head Cable	--	48-53-2673	5/16" x 35' Inner Core Rust Resistant Bulb Head Cable
--	48-53-2562	5/16" x 25' Inner Core Rust Resistant Drop Head Cable	--	48-53-2674	5/16" x 50' Inner Core Rust Resistant Bulb Head Cable
--	48-53-2563	1/4" x 25' Inner Core Rust Resistant Bulb Head Cable	--	48-53-2675	3/8" x 35' Inner Core Rust Resistant Coupling Cable
--	48-53-2564	1/4" x 25' Inner Core Rust Resistant Drop Head Cable	--	48-53-2676	3/8" x 25' Inner Core Rust Resistant Coupling Cable
--	48-53-2571	5/16" x 25' Inner Core Bulb Head Cable	--	48-53-2681	Small Bulb Head
--	48-53-2572	5/16" x 25' Inner Core Drop Head Cable	--	48-53-2682	Small Drop Head
--	48-53-2573	1/4" x 25' Inner Core Bulb Head Cable	--	48-53-2683	1" Spade Bit
--	48-53-2574	1/4" x 25' Inner Core Drop Head Cable	--	48-53-2684	1" C-Cutter
--	48-53-2671	1/4" x 35' Inner Core Rust Resistant Bulb Head Cable	--	48-53-2685	5 pc. Small Drain Line Kit
--	48-53-2672	1/4" x 50' Inner Core Rust Resistant Bulb Head Cable			

NOTE

Regarding parts to be lubricated:
Apply a light coating of Type "J" grease (49-08-4220)
to all highlighted parts shown prior to installation.

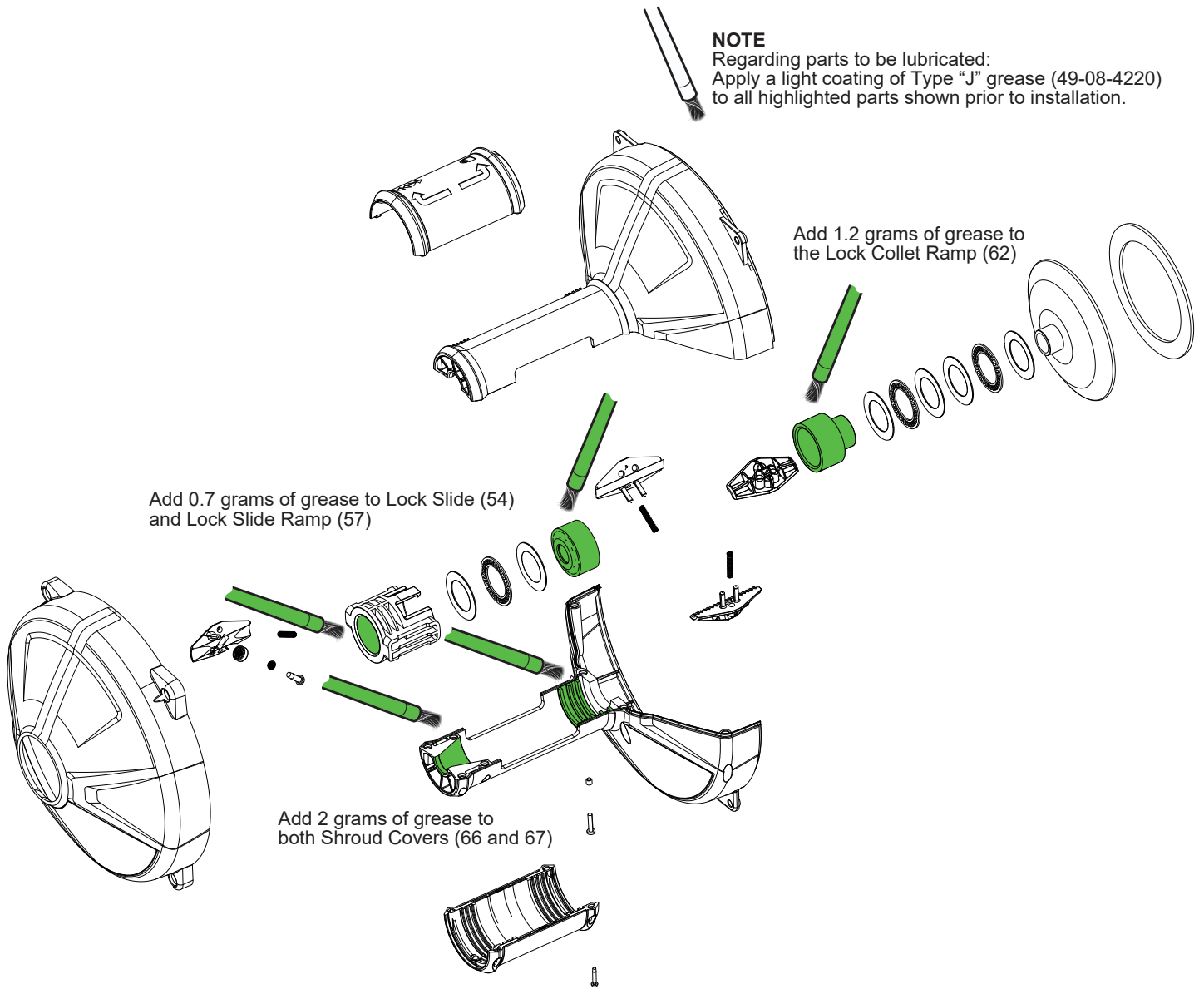

Add 0.7 grams of grease to Lock Slide (54)
and Lock Slide Ramp (57)

Add 1.2 grams of grease to
the Lock Collet Ramp (62)

Add 2 grams of grease to
both Shroud Covers (66 and 67)