

For Residential and Commercial Applications

Job Name		Engineer / Architect	
Job Location		Wholesaler	
Submittal Date		Contractor	

CEPX19 Multi Turn Angle Stop - Cold Expansion Barb (for PEX)x Compression

Use: For use in potable water distribution systems. Not intended for recirculating systems that produce continuous use temperatures above 115° F. For those applications, use our KT™ series ball stop.

Design Features:

- **Machined, one-piece brass body** provides strength, durability, and long-lasting performance
- **Easy-to-remove handle** with screw attachment helps protect against accidental operation during rough-ins
- **No Lead**
- **PEX end** designed to ASTM F1960
- **For use with** ASTM F876 PEX tubing, in ASTM F877 water distribution systems

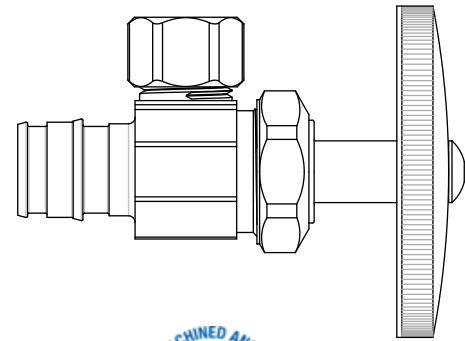

Operating Specifications:

Temperature: 40° - 140°F
Pressure: 125 PSI maximum

Standard

STOP MATERIAL SPECIFICATIONS	
Body	<i>Brass, chrome plated</i>
Stem	<i>POM</i>
Bib & Packing Washer	<i>Rubber</i>
Handle	<i>Polycarbonate</i>
Handle Screw	<i>Steel, zinc plated</i>
Compression Nut	<i>Brass, chrome plated</i>
Packing Nut	<i>Brass, chrome plated</i>
Compression Sleeve	<i>Brass</i>

No Lead

STOP MATERIAL SPECIFICATIONS	
Body	<i>No-Lead brass, chrome plated</i>
Stem	<i>POM</i>
Bib & Packing Washer	<i>Rubber</i>
Handle	<i>Polycarbonate</i>
Handle Screw	<i>Steel, zinc plated</i>
Compression Nut	<i>Brass, chrome plated</i>
Packing Nut	<i>Brass, chrome plated</i>
Compression Sleeve	<i>Brass</i>

This specification and all information contained herein is the confidential and exclusive property of BrassCraft Manufacturing, and shall not be disclosed to others without the written consent of BrassCraft Mfg. This specification must be returned to BrassCraft Mfg if requested.



CEPX19 Multi Turn Angle Stop - Cold Expansion Barb (for PEX)x Compression

Standard Part Listing:

- CEPX19L1 CB 1/2" nom cold expansion barb (for PEX) inlet x 3/8" OD compression, chrome plated, less nut and ferrule, bulk

No-Lead Part Listing:

- CEPX19X C 1/2" nom cold expansion barb (for PEX) inlet x 3/8" OD compression, chrome plated
- CEPX19L1X CB 1/2" nom cold expansion barb (for PEX) inlet x 3/8" OD compression, chrome plated, less nut and ferrule, bulk

PART DIMENSIONS (Inches)		
Model	DIM. A	DIM. B
CEPX19X	.93	2.69
CEPX19L1	.74	2.69
CEPX19L1X	.74	2.69

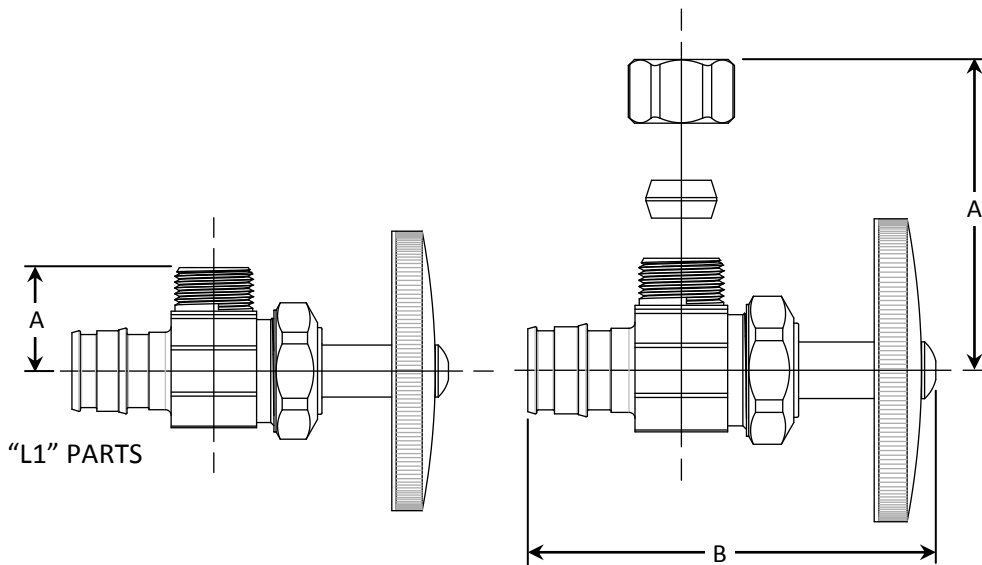

Listings & Certifications:

- IAPMO listed to ASME A112.18.1 / CSA B125.1 (File # 0645)
- CSA listed to ASME A112.18.1 / CSA B125.1 (File # 204593)
- No-Lead product CSA listed to Low Lead Content Certification Program – Plumbing Products Class 6853-01



This specification and all information contained herein is the confidential and exclusive property of BrassCraft Manufacturing, and shall not be disclosed to others without the written consent of BrassCraft Mfg. This specification must be returned to BrassCraft Mfg if requested.

BrassCraft®