

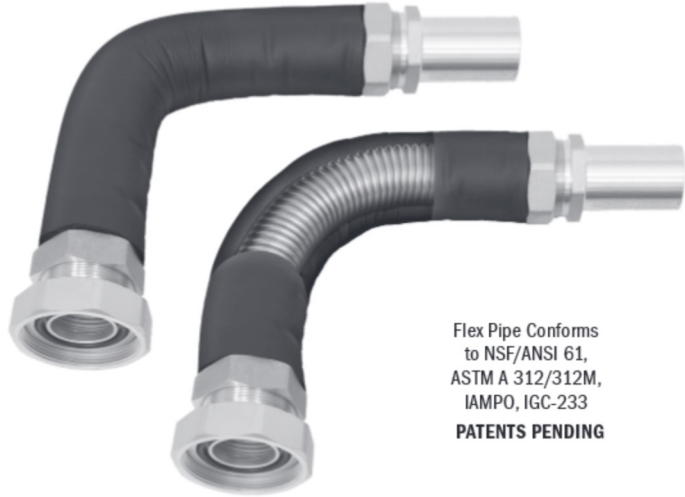

Specifications & Preparing for Installation

(not applicable to all kits)

- Included in select Complete Near Boiler Piping Kits
- Flexible Supply/Return lines designed to accommodate a wide variety of boiler installations
- Tubing may be cut for installations in close quarters



	3/4"	1"	1 1/4"
Inner Diameter	0.83"	1.03"	1.26"
Max Operating Temperature	212°	212°	212°
Max Cold Working Pressure	176 PSI	147 PSI	110 PSI

Flex Pipe Conforms to NSF/ANSI 61, ASTM A 312/312M, IAMPO, IGC-233
PATENTS PENDING



IMPORTANT! Tighten End Connections

1. Remove the nut and check that the fitting internal components are in place (silicone ring and isolation ring).
2. Replace the loosened nut and internal components as shown in the illustration to the right. Turn the nut clockwise two revolutions on the threads. Before tightening the nut, insert the tubing completely in the fitting to the tubing stop until it meets the internal wall. If done correctly, the tubing should be approximately one inch, or four to five corrugations inside the fitting.
3. Hold the fitting on the pipe and tighten the nut onto the fitting using the appropriate torque as shown in the table below.

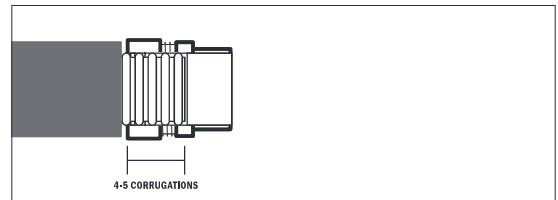
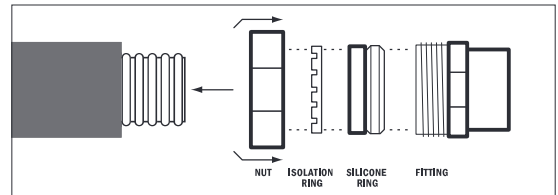

Tube Size (Inch)	3/4"	1"	1 1/4"
Torque Value (Ft./lb)	≈44–48	≈72–76	≈120–140



To Cut Tubing (If Desired)

The amount of Hydro-Core Flex Piping provided is suitable for wide range of boilers. However, tubing may be cut to suit the needs of your specific installation if so desired. Retaining excess length will not effect the performance of the system.

1. Remove end connections.
2. Measure the desired pipe length and mark this point on the insulation.
3. Remove the insulation beyond this mark – **DO NOT CUT THE TUBING.**
4. Measure one inch of exposed pipe above the insulation. This is the cut point.
5. Using a metal tube cutter, cut the tube at the cut point.
Cut MUST be centered in a valley between corrugations.
6. Insert tube into the fitting, then tighten end connections.

Warning:

- To avoid crimping the pipe, DO NOT use excess force.
- Cut must be a clean cut. A rough cut with irregular edges can perforate the silicone ring and cause leakage.
- **Caution** should be used when handling the flex piping with the end fittings removed due to potential for injury on a sharp edge.

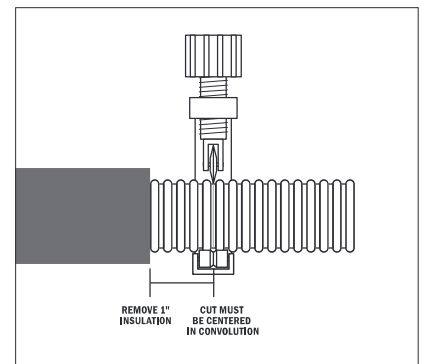

Complete Near Boiler Piping Kit Installations

BOILERS WITH INTERNAL CIRCULATOR PUMPS

WARNING!

- Both end connections of the flex piping are loosely assembled at the factory & **MUST** be properly tightened as part of product installation. **Caution** should be used when handling the flex piping with the end fittings removed due to potential for injury on a sharp edge.

Before Installation

- Review boiler manufacturers' installation literature for any required/recommended clearances for manifold installation.

Installation

PRESS CONNECTIONS: See Pro-Connect Press Installation Instructions for specific requirements.

- Establish the "as installed" location of the Hydro-Core Manifold **A**.
- Bend the System Supply Piped Assembly **B** and System Return Piped Assembly **C** to the desired path using the maximum radius possible to minimize the frictional losses.
- Adjust the System Supply Piped Assembly **B** and System Return Piped Assembly **C** length as desired per the instructions provided on page 2 making sure to include the length of piping installed into the fittings on both ends.
- Tighten the end connection on both ends of each flex pipe **B** & **C** per the instructions provided on page 2.
- Loosely assemble the System Supply Piped Assembly **B** and System Return Piped Assembly **C** to the respective boiler ports.
- Connect the union nut of the System Supply Piped Assembly **B** and System Return Piped Assembly **C** to the respective Hydro-Core Manifold **A** ports and fully tighten.
- Support the near boiler piping assembly with hangers and clamps.
- Connect the Hydro-Core Manifold **A** to the remaining hydronic system.
- Fully tighten the System Supply Piped Assembly **B** and System Return Piped Assembly **C** fittings at the boiler.
- Combi Boiler Kits (4FK5-CH/ 5FK5-CH):** Remove side pipe plug from System Supply Piped Assembly **B** and screw the **30 PSI** pressure relief valve into the threaded port. The discharge line from the PRV should pitch downward and terminate 6" above drains where discharge will be clearly visible. The discharge end of the line shall be plain (unthreaded) and a minimum of 3/4" in diameter. The discharge line material must be suitable for water at least 180° Fahrenheit. The discharge line shall be as short and straight as possible such that the arrangement does not reduce the relieving capacity of the pressure relief valve. No valve of any type may be installed in the discharge line of the pressure relief valve. See included Isolator EXP/E2/E3 directions for Domestic Water installation and servicing directions.
- Pressure test the system to ensure that all connections are pressure tight. **Caution** should be used during all pressure testing to avoid potential personal injury.

FOR WALL HUNG BOILERS WITH INTERNAL CIRCULATOR PUMPS

PRESS SYSTEM PIPING	IPS SYSTEM PIPING	SWT SYSTEM PIPING
8FK3-WIF	4FK3-WIF	5FK3-WIF
8FK3-WIF-18-2	4FK3-WIF-18-2	5FK3-WIF-18-2
8FK3-WIS	4FK3-WIS	5FK3-WIS
8FK4-WIF	4FK4-WIF	5FK4-WIF

FOR WALL HUNG BOILERS WITH INTERNAL CIRCULATOR PUMPS

PRESS SYSTEM PIPING	IPS SYSTEM PIPING	SWT SYSTEM PIPING
8FK3-WIF-18	4FK3-WIF-18	5FK3-WIF-18
8FK3-WIS-18	4FK3-WIS-18	5FK3-WIS-18
8FK4-WIF-18	4FK4-WIF-18	5FK4-WIF-18
8FK4-WIS-18	4FK4-WIS-18	5FK4-WIS-18

FOR SELECT COMBI BOILERS

PRESS SYSTEM PIPING	IPS SYSTEM PIPING	SWT SYSTEM PIPING
8FK5-CH	4FK5-CH	5FK5-CH
8FK4R3-WIF-E3	4FK4R3-WIF-E3	5FK4R3-WIF-E3

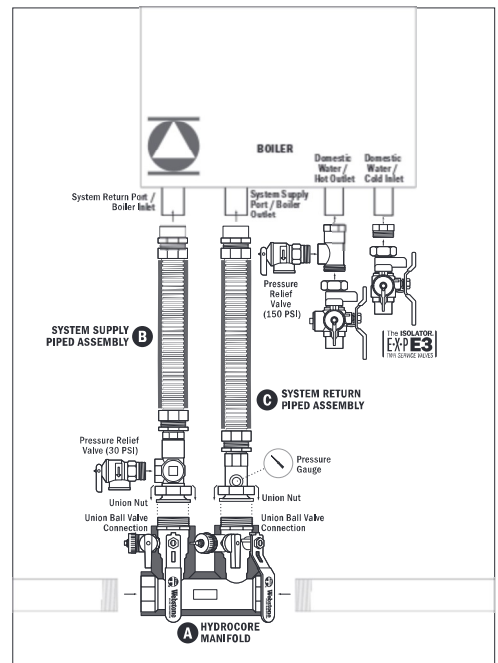
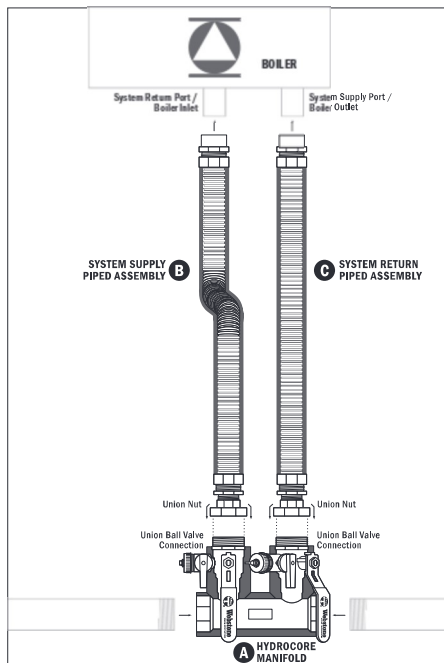
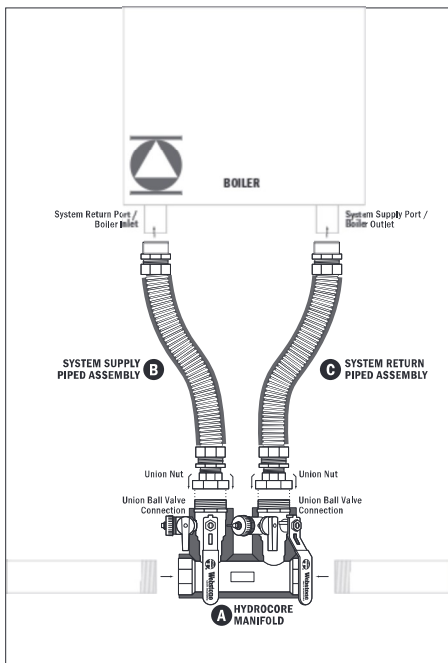

COMPLETE NEAR BOILER PIPING KITS

BOILERS WITH EXTERNAL CIRCULATOR PUMPS

WARNING!

- Both end connections of the flex piping are loosely assembled at the factory & **MUST** be properly tightened as part of product installation. **Caution** should be used when handling the flex piping with the end fittings removed due to potential for injury on a sharp edge.

Before Installation

- The Circulator Pump **D** is sold separately (see the boiler manufacturer for recommendation on suitable models). The Hydro-Core kits are designed to accommodate a 6 1/2" long circulator pump.
- Review boiler manufacturers' installation literature for any required/recommended clearances for manifold installation.

Installation

PRESS CONNECTIONS: See *Pro-Connect Press Installation Instructions* for specific requirements.

- Disassemble the System Supply **E** and Return Supply **F** Union Connections from their respective piped assemblies.
- Assemble the System Supply **E** and Return Supply **F** Union Connections to their respective boiler ports.
- Loosely connect the Circulator Pump **D** to the Hydro-Core **A** flanged ball valve connection making sure the flange gaskets are properly located. **IMPORTANT:** Verify the installation direction of the circulator pump, it should pump into the boiler.
- Loosely connect the Circulator Pump **D** flange to the flange on the System Return Piped Assembly **C**.
- Follow the instructions for your installation type.

COPPER/COPPER - Loosely connect the union nut on the System Supply Piped Assembly **B** to the Hydro-Core **A** union ball valve connection. Loosely connect the System Supply Piped Assembly **B** and System Return Piped Assembly **C** Union to their respective union connections already connected to the boiler.

COPPER/FLEX - Loosely connect the System Return Piped Assembly **A** to the Return Supply Union Connection **F** already connected to the boiler.

- Align the Circulator Pump **D** to the desired position ensuring that both gaskets are properly aligned.
- Fully tighten the bolts to the two-flanged connections on the Circulator Pump **D** (Hydro-Core and pipe sides).
- Follow the instructions for your installation type.

COPPER/COPPER - Fully tighten the System Supply **B** union nut to the Hydro-Core **A** union ball valve connection. Fully tighten the union nuts of the System Supply **E** and Return Supply **F** Union.

COPPER/FLEX - Fully tighten the union nut of the Return Piped Assembly **C** and System Return **F** Union Connection.

- Support the near boiler piping assembly with hangers and clamps.

10. COPPER/FLEX INSTALLATION ONLY (COPPER/COPPER skip to step 11)

- Bend the flex line of the System Supply Piped Assembly **C** to the desired path using the maximum radius possible to minimize the frictional losses.
- Adjust the flex pipe length as desired/required per the instructions provided on page 2 making sure to include the length of piping installed into the fittings on both ends.
- Tighten the flex pipe end connection on both ends per the instructions provided on page 2.
- Connect & fully tighten the System Supply Piped Assembly **B** to the system supply Union Connection **E** at the boiler.
- Connect and fully tighten the union nut on the System Supply Piped Assembly **B** to the Hydro-Core **A** union ball valve connection.

- Connect the Hydro-Core Manifold **A** to the remaining hydronic system.
- Pressure test the system to ensure that all connections are pressure tight. **Caution** should be used during all pressure testing to avoid potential personal injury.

FOR WALL HUNG BOILERS

PRESS SYSTEM PIPING	IPS SYSTEM PIPING	SWT SYSTEM PIPING
8CC4-WHN	4CC4-WHN	5CC4-WHN

FOR WALL HUNG BOILERS

PRESS SYSTEM PIPING	IPS SYSTEM PIPING	SWT SYSTEM PIPING
8CF4L-WH144 8CF5L-WH245	4CF4L-WH144 4CF5L-WH245	5CF4L-WH144 5CF5L-WH245

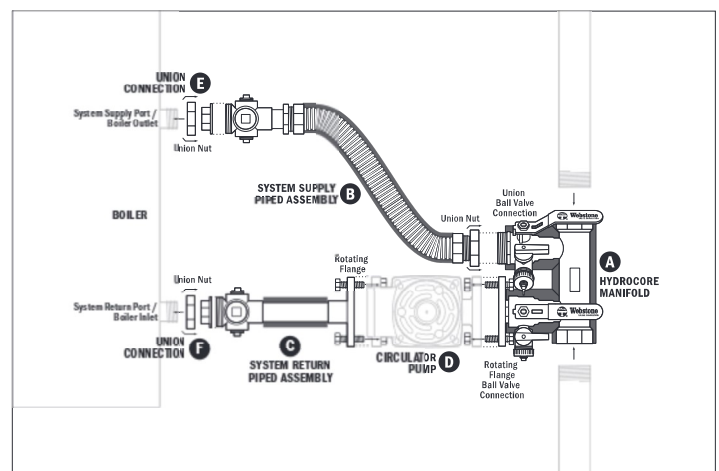
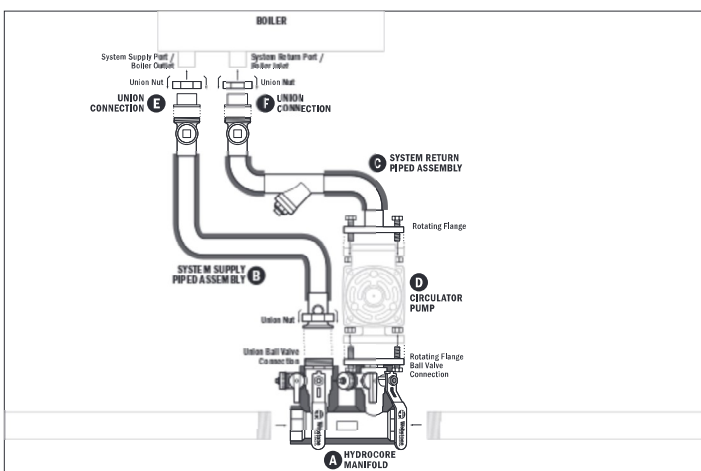

FOR FLOOR STANDING, SIDE MOUNT BOILERS

PRESS SYSTEM PIPING	IPS SYSTEM PIPING	SWT SYSTEM PIPING
8CC4-080	4CC4-080	5CC4-080
8CC4-105	4CC4-105	5CC4-105
8CC4-150	4CC4-150	5CC4-150
8CC4-210	4CC4-210	5CC4-210
8CC4L-080	4CC4L-080	5CC4L-080
8CC4L-105	4CC4L-105	5CC4L-105
8CC4L-150	4CC4L-150	5CC4L-150
8CC4L-210	4CC4L-210	5CC4L-210

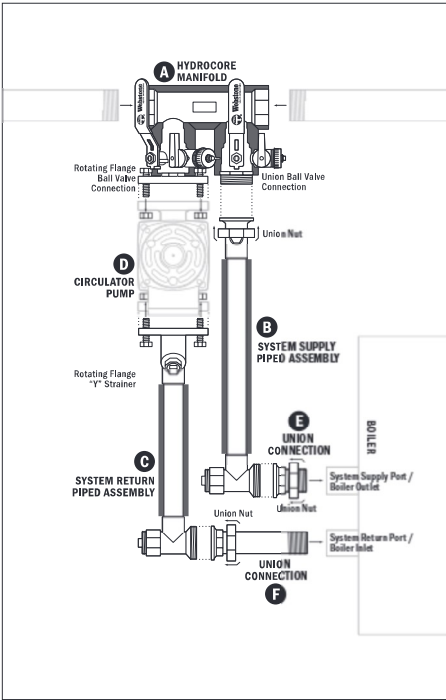

FOR FLOOR STANDING, SIDE MOUNT BOILERS

PRESS SYSTEM PIPING	IPS SYSTEM PIPING	SWT SYSTEM PIPING
8CF4-FS184	4CF4-FS184	5CF4-FS184
8CF5-FS185	4CF5-FS185	5CF5-FS185

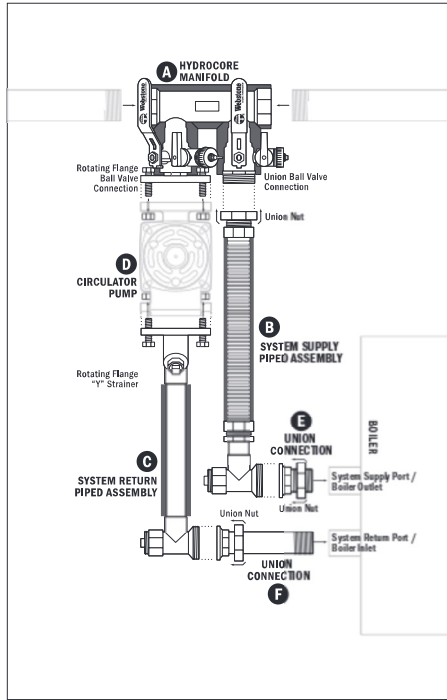

FOR FLOOR STANDING, TOP MOUNT BOILERS

PRESS SYSTEM PIPING	IPS SYSTEM PIPING	SWT SYSTEM PIPING
8CF4R-FT144	4CF4R-FT144	5CF4R-FT144
8CF5-FT245	4CF5-FT245	5CF5-FT245
8CF5-FT2R45	4CF5-FT2R45	5CF5-FT2R45

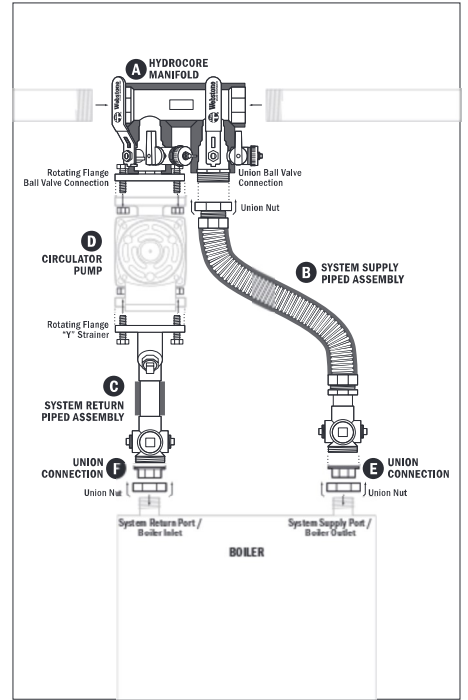

FOR FLOOR STANDING, TOP MOUNT BOILERS

PRESS SYSTEM PIPING	IPS SYSTEM PIPING	SWT SYSTEM PIPING
8CF4L-FT144	4CF4L-FT144	5CF4L-FT144

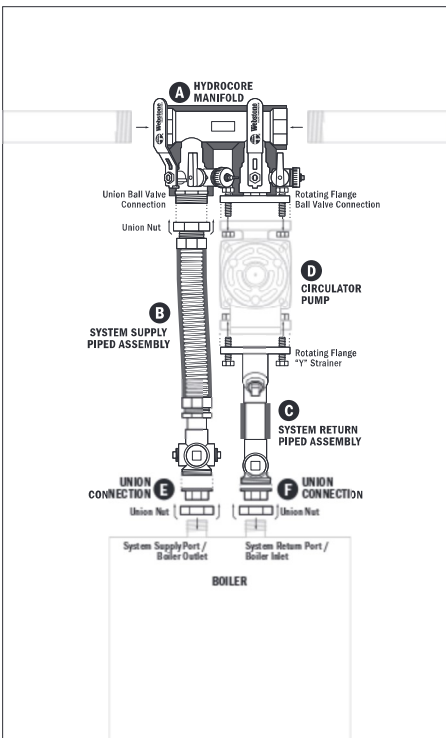

FOR WALL HUNG BOILERS

PRESS SYSTEM PIPING	IPS SYSTEM PIPING	SWT SYSTEM PIPING
8CF4-WH154	4CF4-WH154	5CF4-WH154
8CF4-WH1R44	4CF4-WH1R44	5CF4-WH1R44
8CF4-WH1R54	4CF4-WH1R54	5CF4-WH1R54
8CF4R-WH144	4CF4R-WH144	5CF4R-WH144
8CF5R-WH245	4CF5R-WH245	5CF5R-WH245

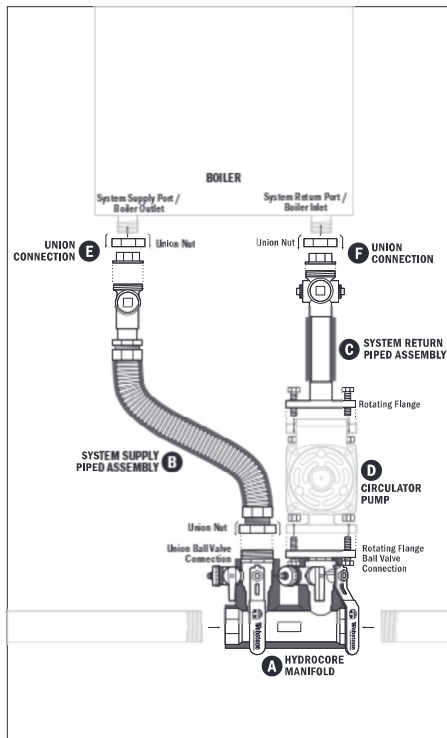

FOR WALL HUNG BOILERS

PRESS SYSTEM PIPING	IPS SYSTEM PIPING	SWT SYSTEM PIPING
8CF4L-WHNB	4CF4L-WHNB	5CF4L-WHNB
8CF5-WH255	4CF5-WH255	5CF5-WH255

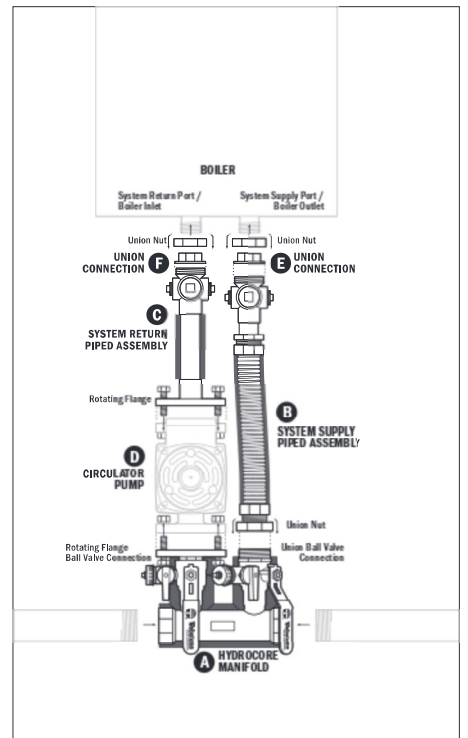

NEAR BOILER COMPONENT KITS

Before Installation

- Circulator Pump **D** sold separately (see boiler manufacturer for suitable models).

Installation

PRESS CONNECTIONS: See Pro-Connect Press Installation Instructions for specific requirements.

- 1. Fabricate the System Return Piped Assembly:**
Solder the Flanged Pump Connection **H** and Union Body Component **I** to opposite ends of a length of copper tubing sized appropriately for your boiler's return line.
- Remove the o-ring from the Hydro-Core End **G** and save for reinstallation.
- 3. Fabricate the System Supply Piped Assembly:**
Solder the Hydro-Core End **G** and Union Body Component **I** to either ends of a length of copper tubing sized appropriately for your boiler's supply line.
- Assemble the System Supply Union Connection **E** to the system supply port.
- Assemble the System Return Union Connection **F** to the system return port.
- Loosely connect the Circulator **D** to the Hydro-Core **A** flanged ball valve connection.
IMPORTANT: The Circulator **D** should pump into the boiler.
- Loosely connect the Circulator **D** flange to the flange on the System Return Piped Assembly.
- Loosely connect the union nut, o-ring and fitting on the System Supply Piped Assembly to the Hydro-Core **A** union ball valve connection.
- Connect the System Supply **E** and System Return Union Connections **F** to their respective piped assemblies.
- Align the Circulator **D** into the desired position. Ensure both pump gaskets are properly aligned.
- Fully tighten the bolts to the two flanged connections.
- Fully tighten the union nut to the Hydro-Core **A** union ball valve connection.
- Fully tighten the union nuts to the union fittings at the boiler.
- Support the near boiler piping assembly with hangers and clamps.
- Connect the Hydro-Core Manifold **A** to the remaining hydronic system.
- Pressure test the system to ensure that all connections are pressure tight. **Caution** should be used during all pressure testing to avoid potential personal injury.

FOR FLOOR STANDING, SIDE MOUNT BOILERS

PRESS SYSTEM PIPING	IPS SYSTEM PIPING	SWT SYSTEM PIPING
88754-FS144	48754-FS144	58754-FS144
88754-FS184	48754-FS184	58754-FS184
88765-FS145	48765-FS145	58765-FS145
88765-FS185	48765-FS185	58765-FS185
88854-FS144	48854-FS144	58775-FS185
88854-FS184	48854-FS184	58854-FS144
		58854-FS184

FOR FLOOR STANDING, SIDE MOUNT BOILERS

PRESS SYSTEM PIPING	IPS SYSTEM PIPING	SWT SYSTEM PIPING
88765-FS245	48765-FS245	58765-FS245

FOR FLOOR STANDING, SIDE MOUNT BOILERS

PRESS SYSTEM PIPING	IPS SYSTEM PIPING	SWT SYSTEM PIPING
88765-FS345	48765-FS345	58765-FS345
88865-FS345	48865-FS345	58865-FS345

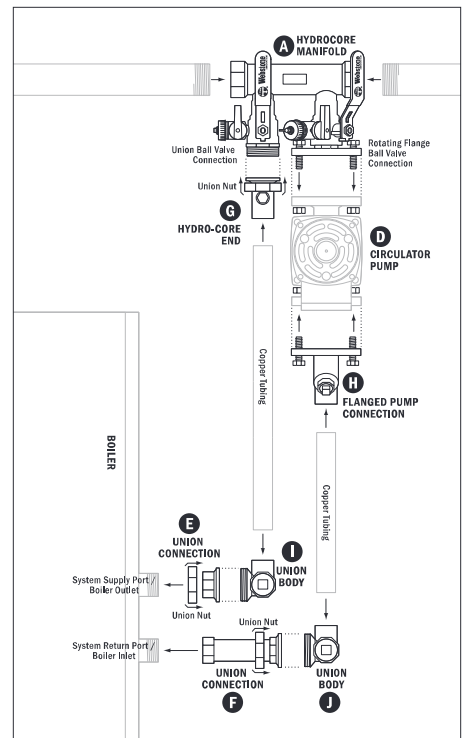
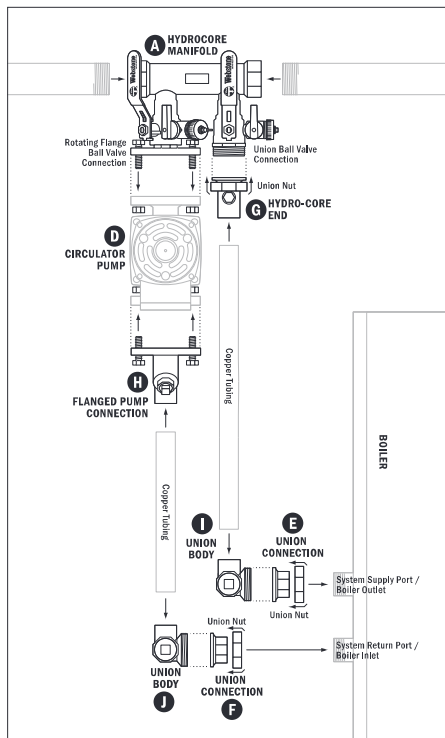
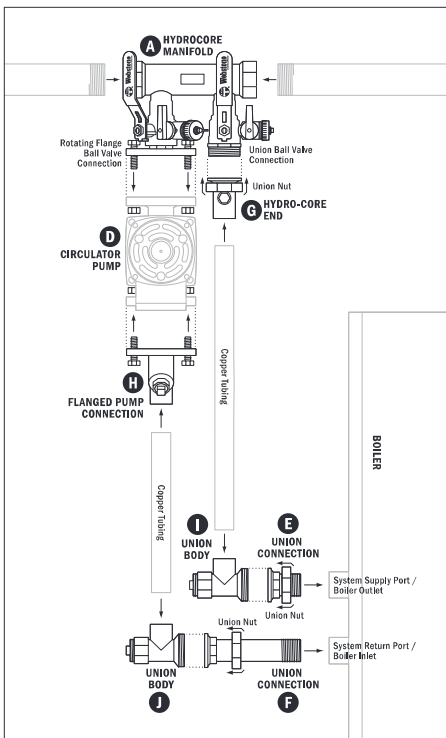

FOR FLOOR STANDING, TOP MOUNT BOILERS

PRESS SYSTEM PIPING	IPS SYSTEM PIPING	SWT SYSTEM PIPING
88754-FT144 88854-FT144	48754-FT144 48854-FT144	58754-FT144 58854-FT144

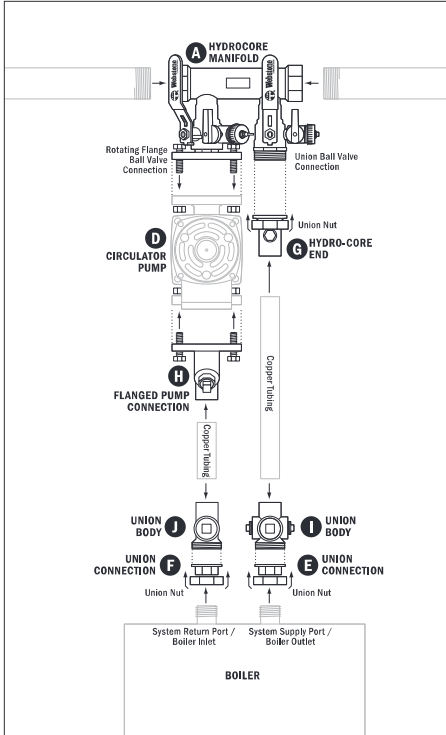

FOR FLOOR STANDING, TOP MOUNT BOILERS

PRESS SYSTEM PIPING	IPS SYSTEM PIPING	SWT SYSTEM PIPING
88765-FT245 88765-FT2R45	48765-FT245 48765-FT2R45	58765-FT245 58765-FT2R45

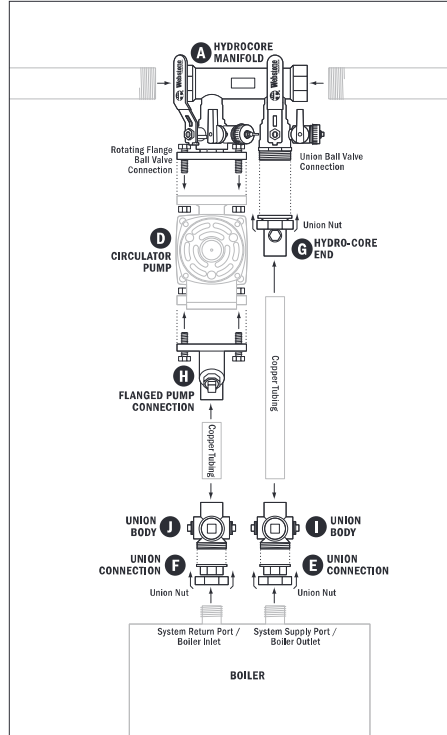

FOR FLOOR STANDING, TOP MOUNT BOILERS

PRESS SYSTEM PIPING	IPS SYSTEM PIPING	SWT SYSTEM PIPING
88754-FT344	48754-FT344	58754-FT344

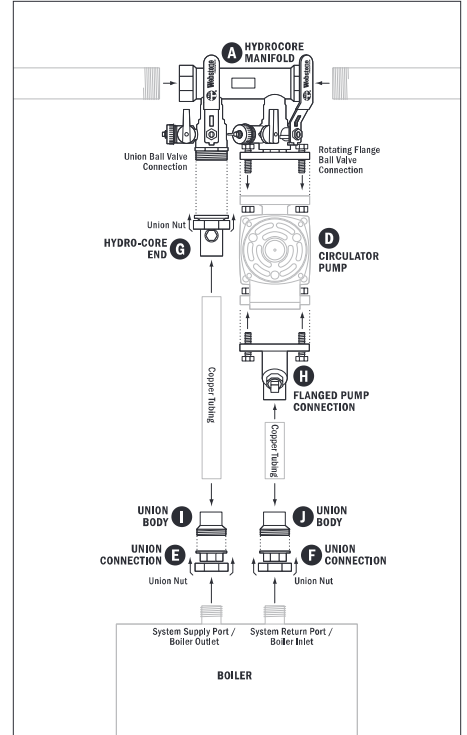

FOR WALL HUNG BOILERS

PRESS SYSTEM PIPING	IPS SYSTEM PIPING	SWT SYSTEM PIPING
88754-WH144 88754-WH154 88754-WH1R44 88754-WH1R54 88854-WH144	48754-WH144 48754-WH154 48754-WH1R44 48754-WH1R54 48854-WH144	58754-WH144 58754-WH154 58754-WH1R44 58754-WH1R54 58854-WH144

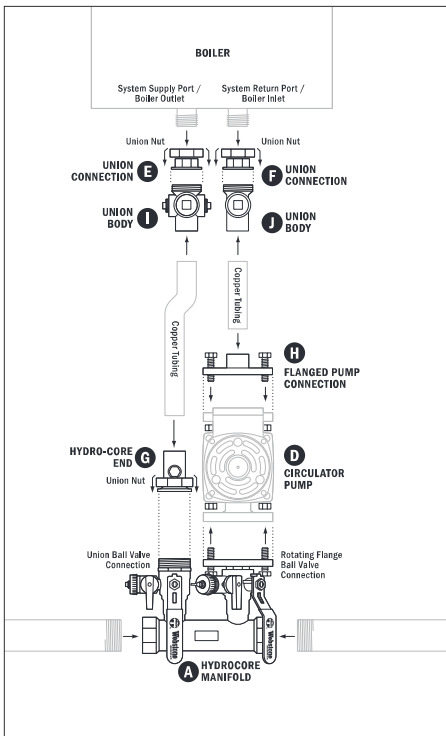

FOR WALL HUNG BOILERS

PRESS SYSTEM PIPING	IPS SYSTEM PIPING	SWT SYSTEM PIPING
88765-WH245 88765-WH255 88854-WHNB 88865-WH245	48765-WH245 48765-WH255 48854-WHNB 48865-WH245	58765-WH245 58765-WH255 58854-WHNB 58865-WH245

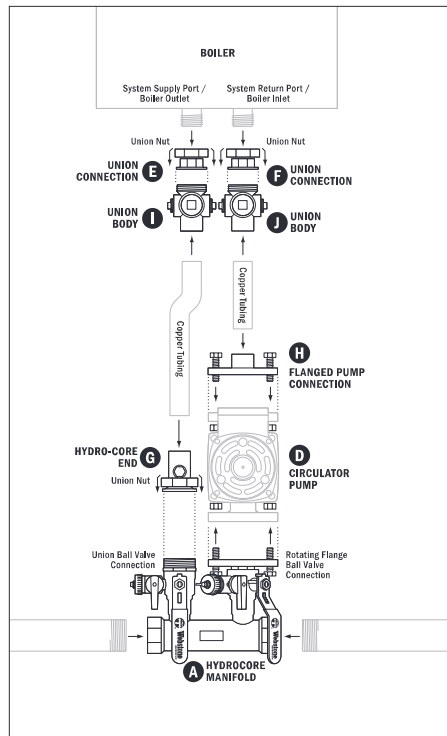

FOR WALL HUNG BOILERS

PRESS SYSTEM PIPING	IPS SYSTEM PIPING	SWT SYSTEM PIPING
88765-WH345	48765-WH345	58765-WH345

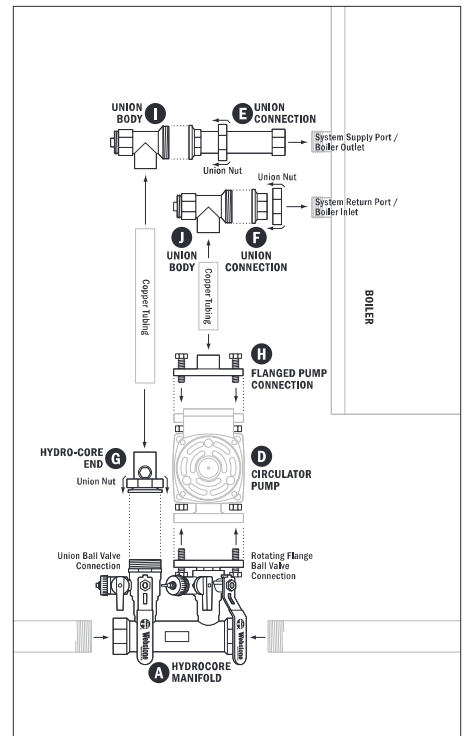

Boilers shown for illustration purposes only.

HYDRO-CORE MANIFOLD

Manifold Only Installations

- **Note:** Not all installation steps applicable to all Manifold styles.

Installation

PRESS CONNECTIONS:

See *Pro-Connect Press Installation Instructions for specific requirements.*

1. Remove the o-ring from the Hydro-Core End(s) **G** and save for reinstallation.
2. Connect the Hydro-Core End (s) **G** to branch tubing.
3. Loosely connect the Circulator **D** to the Hydro-Core **A** flanged ball valve connection.
IMPORTANT: The Circulator **D** should pump into the boiler, if applicable.
4. Loosely connect the Hydro-Core End(s) **G** union nut, o-ring and fitting to the Hydro-Core **A** union ball valve connection.
5. Align the Circulator **D** into the desired position.
Ensure both pump gaskets are properly aligned.
6. Fully tighten the bolts to the flanged connection.
7. Fully tighten the union nut to the Hydro-Core **A** union ball valve connection.
8. Support the piping assembly with hangers and clamps.
9. Connect the Hydro-Core Manifold **A** to the remaining hydronic system.
10. Pressure test the system to ensure that all connections are pressure tight.
Caution should be used during all pressure testing to avoid potential personal injury.

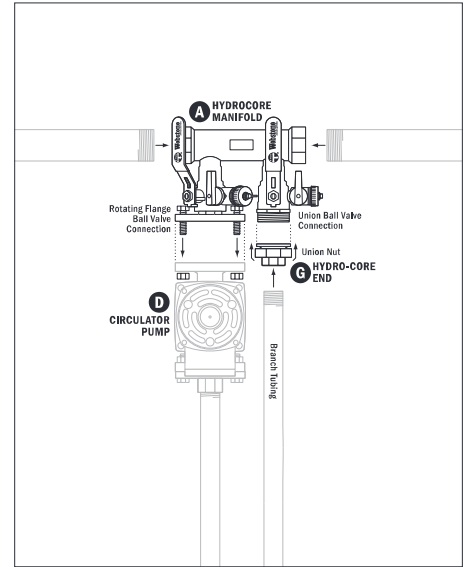

Parts and Accessories

See www.webstonevalves.com/hydro-core/boilercompatibility for a complete list of parts and accessories.

Interested in upgrading your Manifold Kit to a Complete or Component kit? Or do you have an unusual set of system requirements or a particularly unique area to work within? Craft your own kit - all Hydro-Core components are available for individual purchase. A solution is available for any given need.

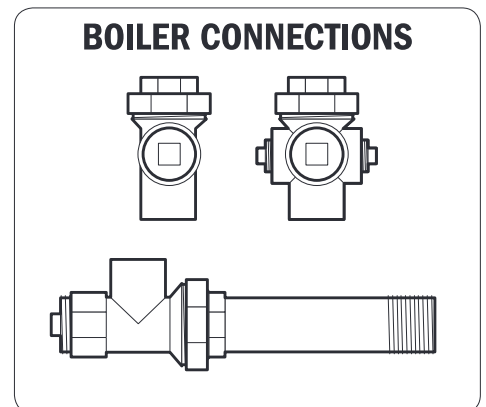
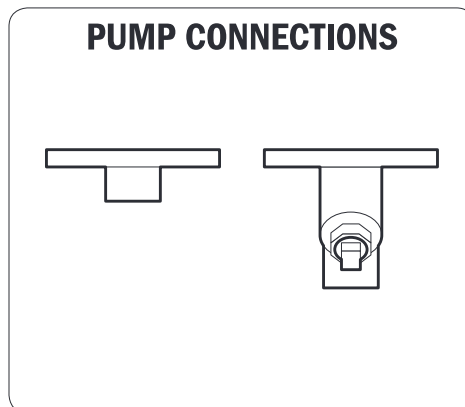
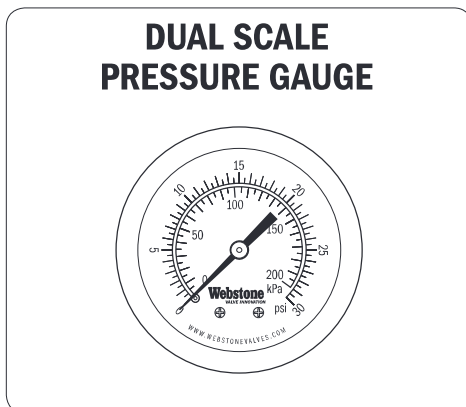
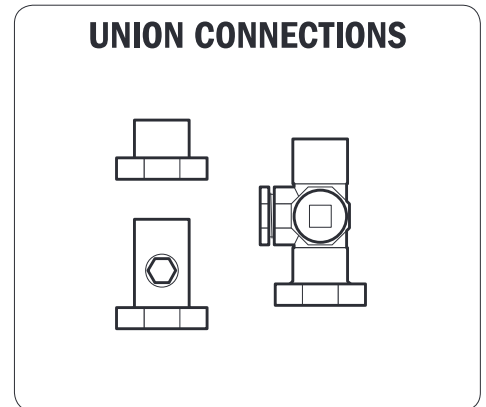
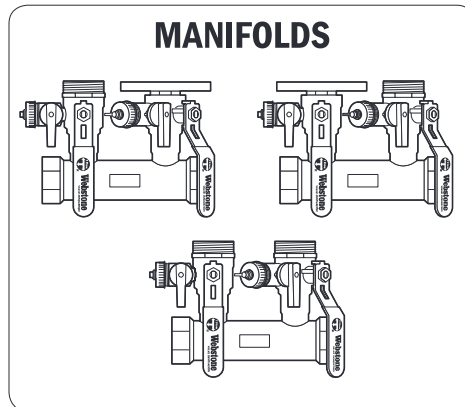

Secondary System Purging

Typically boiler manufacturers want to make sure that any foreign matter (dirt, shavings, PTFE thread tape, etc.) is flushed out of the Hydronic Piping System before fluid begins to flow between the boiler and the piping system.

To purge the secondary system the following is needed:

- A hose w/ 3/4" hose thread connection
- A water source
- Power to the circulator pump in the secondary loop

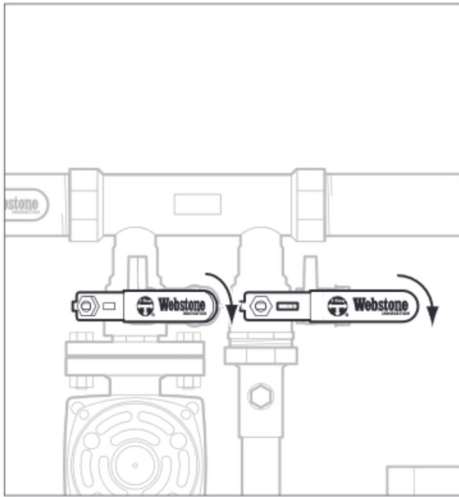

1. Turn the lever handles on both Hydro-Core ball valves so that they are parallel to the flange and the main valves are in the closed position. This will prevent any debris from entering the near boiler loop during flushing. If multiple circuits are present, repeat for each circuit.

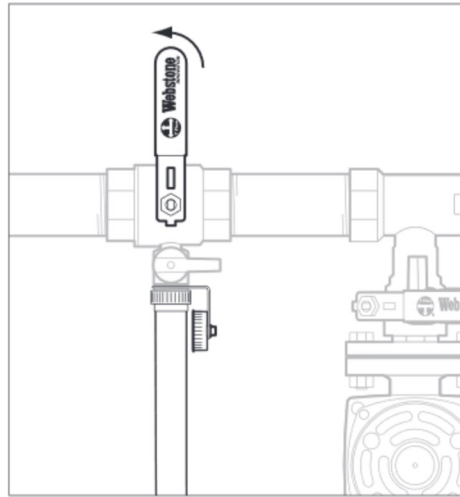

2. Close the main valve and remove the cap from the drain valve in the secondary loop.
3. Connect the hose to the purging port on the drain valve in the secondary loop.
4. Direct the other end of the hose into a bucket or drain.

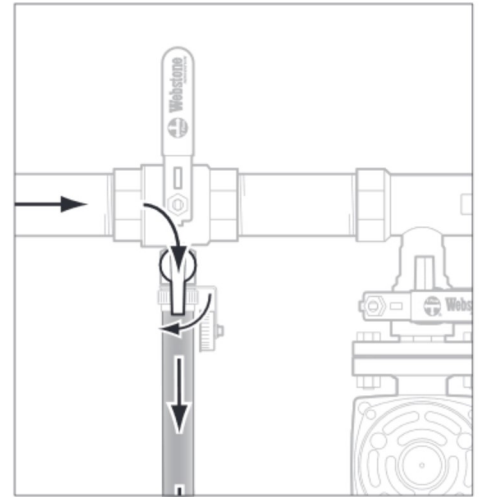

5. With the main water supply on and flowing into the system, open the purging valve on the drain in the secondary loop.

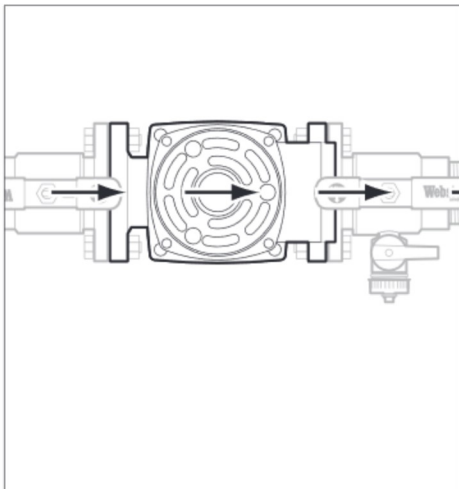

6. Turn on the circulator pump in the secondary system to purge the entire loop with fresh water.
7. Once the debris has been purged out and the drainage from the hose runs clear, turn off the circulator.

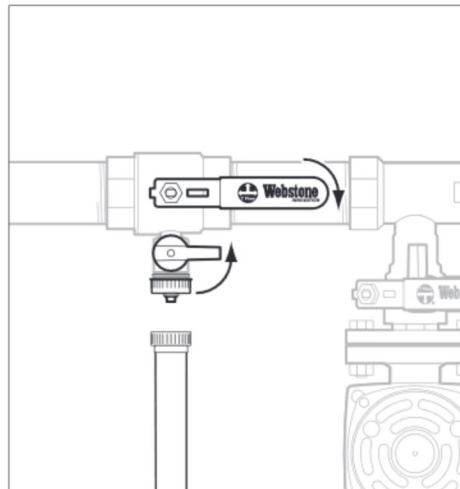

8. Close the purging valve on the drain in the secondary loop.
9. Remove the hose and replace the cap.
10. Open the main valve on the drain valve in the secondary loop.

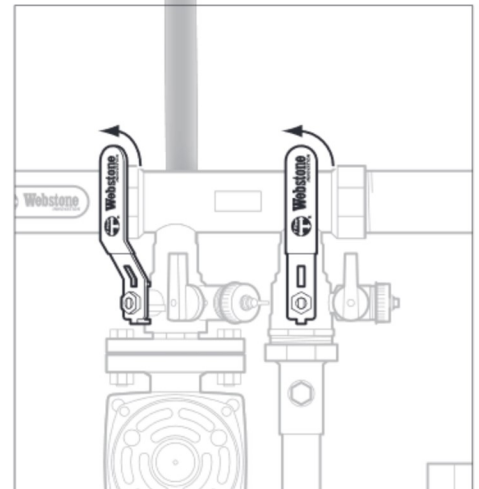

11. Return the lever handled ball valves on the Hydro-Core manifold to their normal operating position (handles perpendicular to the flange). Repeat for each circuit.

Filling/Power Purging

The Hydro-Core and associated NBP offers several beneficial features for a system's startup and future maintenance. At startup the boiler can be isolated from the remaining hydronic system and the trapped air in the boiler and associated piping can be power purged out.

To Power Purge and/or fill the boiler the following is needed:

- Two hoses w/ 3/4" hose thread connection
- A water source
- Power to the circulator pump in the NBP Loop
- 5 gallon bucket (for glycol filling only)

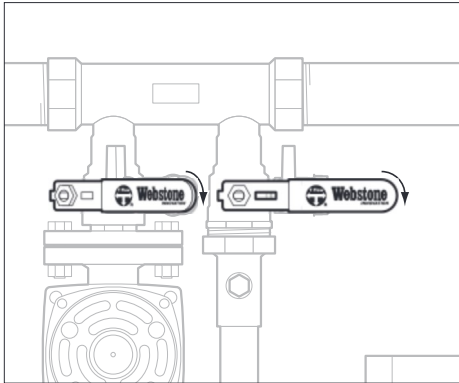

1. Turn the Lever Handles on both Hydro-Core ball valves so that they are parallel to the flange. The T-Flow handle logo indicates the flow pattern inside the valve. The logo should indicate that flow can go through the purging valve and both the supply and return piped assemblies.

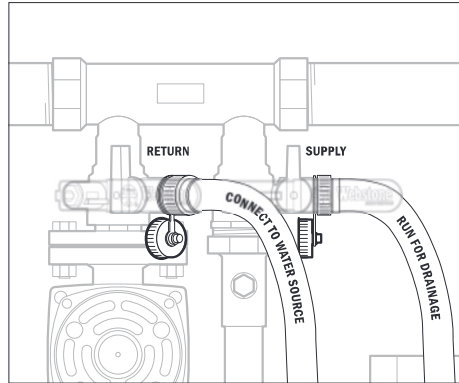

2. Remove both purging valve caps
3. Using a hose, connect a water source to the system return purging valve (located above the flange connection).
4. Connect a hose to the system supply purging valve for drainage.

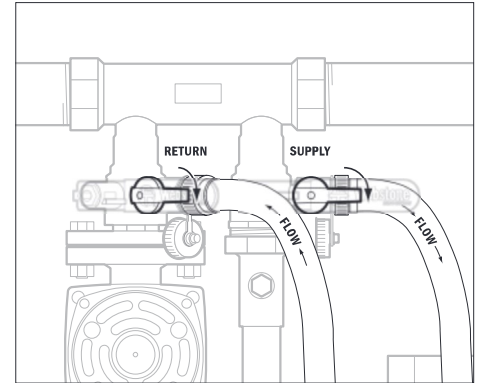

5. Turn the drain handles on both the system return & system supply purging valves into the open position (drain handles parallel with the flange).
6. Turn on the water source and allow water to flow into the circulator from the hose.
7. Allow water to run until all excess air has been purged from the boiler and the water coming from the drainage hose appears clear. If needed, turn on the circulator pump to force water through the system.

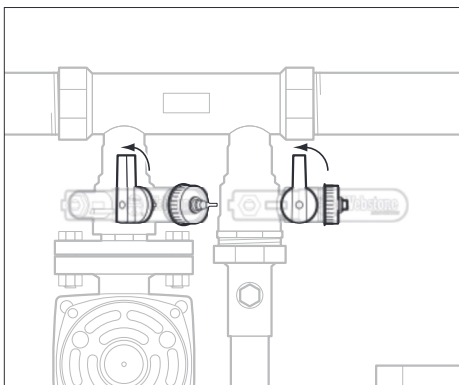

8. Once the air has been purged out and the drainage runs clear, turn off the circulator, close the two purging valves, remove the hoses, and replace the drain caps.
9. The boiler and NBP loop will now be filled with clean fresh water. If a glycol solution is preferred, see steps 2-14 on the next page and follow the instructions for "Descaling the Boiler Heat Exchanger" utilizing glycol rather than a descaling solution.

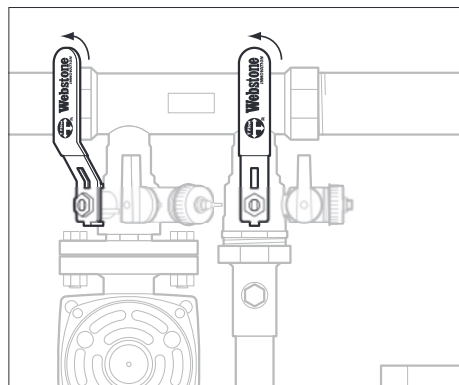

10. Return the lever handled ball valves to their normal operating position (handles perpendicular to the flange).

Strainer Servicing

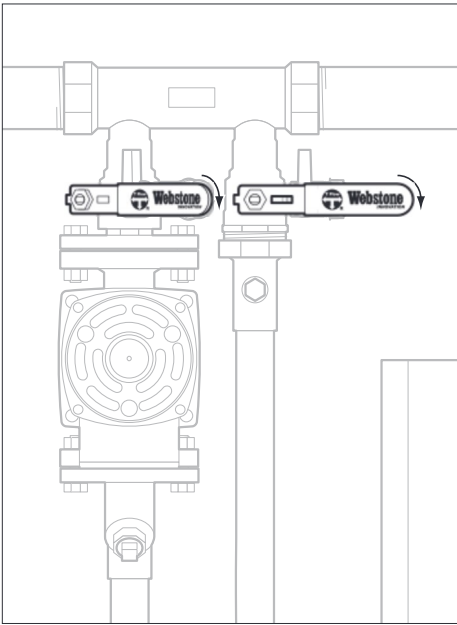

1. Turn the lever handles on both Hydro-Core ball valves so that they are parallel to the flange. The T-Flow handle logo indicates the flow pattern inside the valve. The logo should indicate that flow can go through the purging valve and both the supply and return piped assemblies.

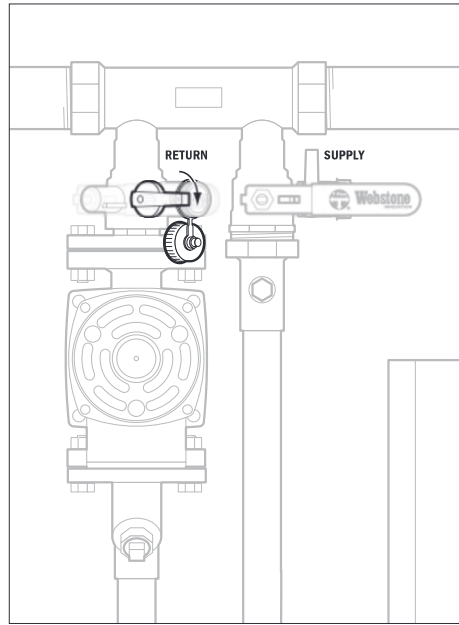

2. Release internal pressure by removing the system return purging valve cap and turning the drain handle on the system return purging valve into the open position (parallel with the flange). Pressure release should emit a small amount of fluid.

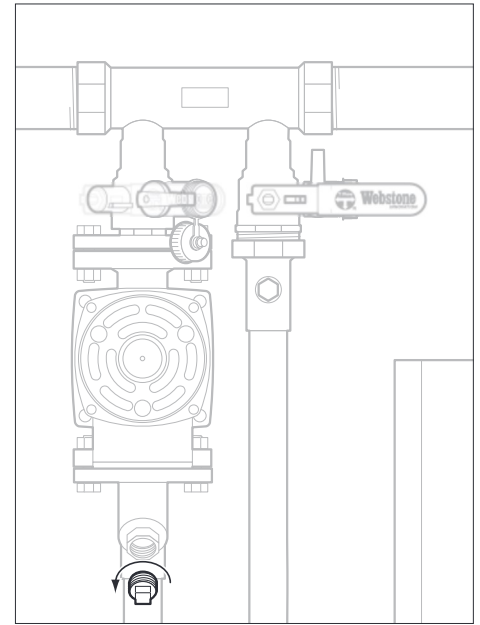

3. Remove the strainer plug by turning it counterclockwise.
4. Clean out the strainer.

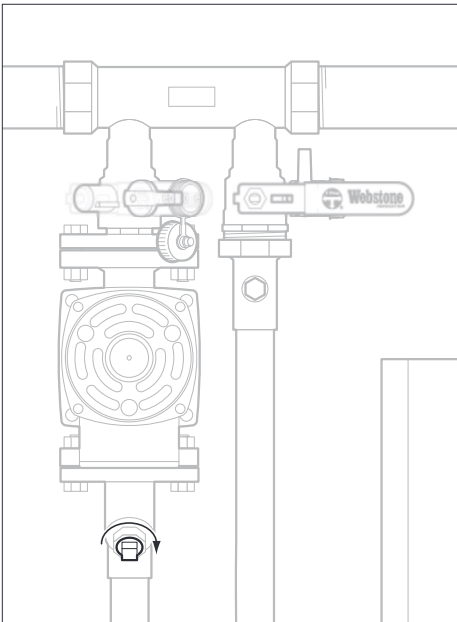

5. Reinstall the plug, ensuring that it is seated properly in the strainer cap.

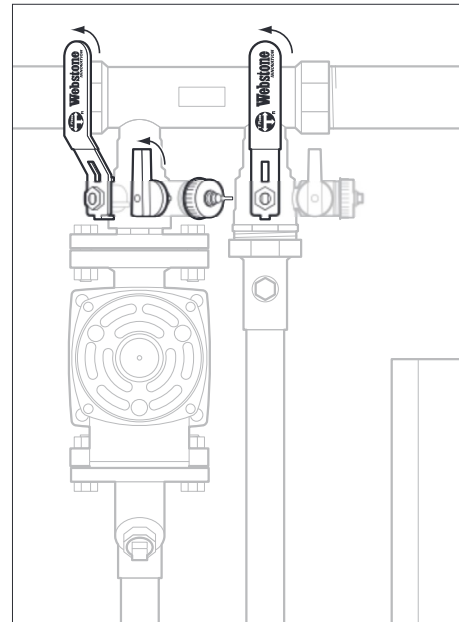

6. Close the purging valve (drain handle perpendicular to the flange).
7. Return the lever handled ball valves to their normal operating position (handles perpendicular to the flange) and replace the cap.
8. Pressure test the system to ensure that all connections are pressure tight.

Boiler Heat Exchanger Descaling/Cleaning

To Descale/Clean the boiler the following is needed:

- Boiler Manufacturer Maintenance Instructions
Should there be a discrepancy or conflict with these instructions, follow the Boiler Manufacturer's instructions.
- Descaling/cleaning solution
- 2 hoses
- Bucket
- Ability to activate the NBP System Circulator

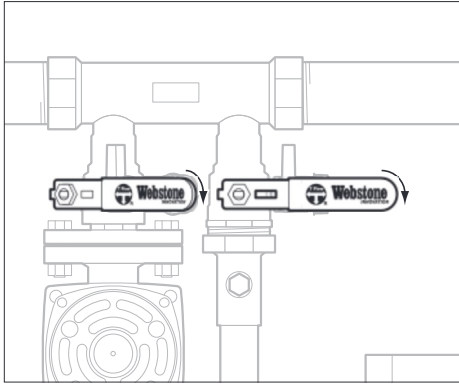

1. Turn the lever handles on both Hydro-Core ball valves so that they are parallel to the flange. The T-Flow handle logo indicates the flow pattern inside the valve. The logo should indicate that flow can go through the purging valve and both the supply and return piped assemblies.

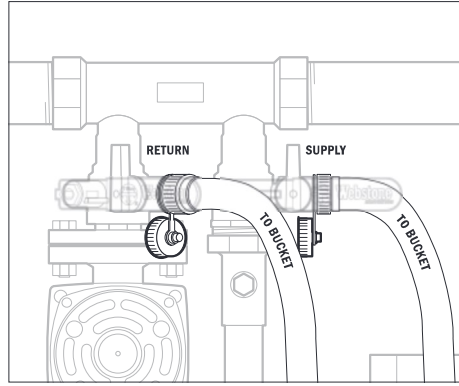

2. Remove both purging valve caps.
3. Connect one of the hoses to the system return purging valve (located above the flange connection).
4. Connect the other hose to the system supply purging valve.
5. Fill a 5 gallon bucket with the boiler manufacturer's recommended cleaning/descaling solution.
6. Place the ends of both hoses into bucket of solution.

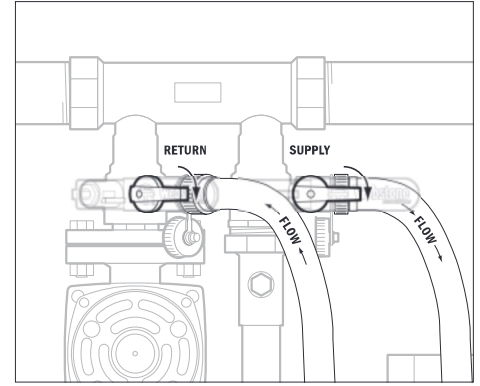

7. Turn the drain handles on both the system return & system supply purging valves into the open position (drain handles parallel with the flange).
8. Turn on the circulator pump in the NBP Loop and allow the solution to flow into and out of the NBP System.
9. See boiler manufacturer maintenance instructions to determine when system is sufficiently cleaned.
10. When boiler is sufficiently cleaned, remove the hose connected to the system return's purging valve from the bucket (system return is the side with the flange connection).

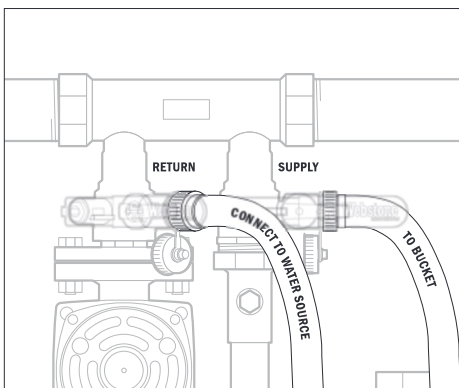

11. Connect system return purging valve hose to a water source.
12. Turn on the water source and allow water to flow into the circulator to purge the entire loop with fresh water. If needed, turn on the circulator pump to force water through the system.
13. Once the solution has been purged out in the bucket and the drainage from the hose on the system supply purging valve runs clear, turn off the circulator.

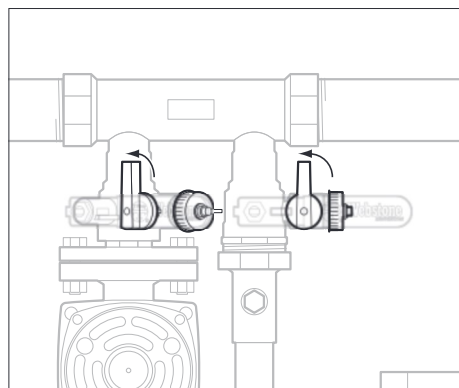

14. Close the two purging valves, remove the hoses, and replace the caps.
15. The boiler and NBP loop will now be filled with clean fresh water. If a glycol solution is preferred, repeat steps 2-14 above with glycol rather than a descaling solution.

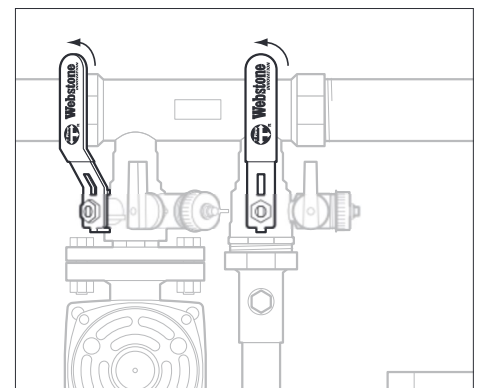

16. Return the lever handled ball valves to their normal operating position (handles perpendicular to the flange).