

INSTALLATION MANUAL

AIR CONDITIONER

Please read this installation manual completely before installing the product. Installation work must be performed in accordance with the national wiring standards by authorized personnel only. Please retain this installation manual for future reference after reading it thoroughly.

Ceiling Concealed Duct



MFL67206516
Rev.01_091124

www.lghvac.com
www.lg.com

Copyright © 2024 LG Electronics Inc. All Rights Reserved.

TIPS FOR SAVING ENERGY

Here are some tips that will help you minimize the power consumption when you use the air conditioner. You can use your air conditioner more efficiently by referring to the instructions below:

- Do not cool excessively indoors. This may be harmful for your health and may consume more electricity.
- Block sunlight with blinds or curtains while you are operating the air conditioner.
- Keep doors or windows closed tightly while you are operating the air conditioner.
- Adjust the direction of the air flow vertically or horizontally to circulate indoor air.
- Speed up the fan to cool or warm indoor air quickly, in a short period of time.
- Open windows regularly for ventilation as the indoor air quality may deteriorate if the air conditioner is used for many hours.
- Clean the air filter once every 2 weeks. Dust and impurities collected in the air filter may block the air flow or weaken the cooling / dehumidifying functions.

For your records

Staple your receipt to this page in case you need it to prove the date of purchase or for warranty purposes. Write the model number and the serial number here:

Model number : _____





Serial number : _____

You can find them on a label on the side of each unit.

Dealer's name : _____

Date of purchase : _____

SAFETY INSTRUCTIONS

	Read the precautions in this manual carefully before operating the unit.
	This symbol indicates that the Operation Manual should be read carefully.
	This appliance is filled with flammable refrigerant.
	This symbol indicates that a service personnel should be handling this equipment with reference to the Installation Manual.

The following safety guidelines are intended to prevent unforeseen risks or damage from unsafe or incorrect operation of the appliance.

The guidelines are separated into 'WARNING' and 'CAUTION' as described below.

 This symbol is displayed to indicate matters and operations that can cause risk. Read the part with this symbol carefully and follow the instructions in order to avoid risk.

WARNING

This indicates that the failure to follow the instructions can cause serious injury or death.

CAUTION

This indicates that the failure to follow the instructions can cause the minor injury or damage to the product.

WARNING

- Installation or repairs made by unqualified persons can result in hazards to you and others.
- Installation of all field wiring and components MUST conform with local building codes or, in the absence of local codes, with the National Electrical Code 70 and the National Building Construction and Safety Code or Canadian Electrical code and National Building Code of Canada.
- The information contained in the manual is intended for use by a qualified service technician familiar with safety procedures and equipped with the proper tools and test instruments.
- Failure to carefully read and follow all instructions in this manual can result in equipment malfunction, property damage, personal injury and/or death.

Installation

- Always perform grounding.
 - Otherwise, it may cause electrical shock.
- For installation of the product, always contact the service center or a professional installation agency.
 - Otherwise, it may cause a fire, electrical shock, explosion or injury.
- Securely attach the electrical part cover to the indoor unit and the service panel to the outdoor unit.
 - If the electrical part cover of the indoor unit and the service panel of the outdoor unit are not attached securely, it could result in a fire or electric shock due to dust, water, etc.
- Always install an air leakage breaker and a dedicated switching board.
 - No installation may cause a fire and electrical shock.
- Do not keep or use flammable gases or combustibles near the air conditioner.
 - Otherwise, it may cause a fire or the failure of product.
- Ensure that an installation frame of the outdoor unit is not damaged due to use for a long time.
 - It may cause injury or an accident.
- Do not disassemble or repair the product randomly.
 - It will cause a fire or electrical shock.
- Do not install the product at a place that there is concern of falling down.
 - Otherwise, it may result in personal injury.
- Use caution when unpacking and installing.
 - Sharp edges may cause injury.
- Use a vacuum pump or Inert (nitrogen) gas when doing leakage test or air purge. Do not compress air or Oxygen and Do not use Flammable gases. Otherwise, it may cause fire or explosion. There is the risk of death, injury, fire or explosion.
- Consult your local dealer regarding what to do in case of refrigerant leakage.
When the air conditioner is to be installed in a small room, it is necessary to take proper measures so that the amount of any leaked refrigerant does not exceed the concentration limit in the event of a leakage. Otherwise, this may lead to an accident due to oxygen depletion.
- Carry out the specified installation work after taking into account earthquakes.
Failure to do so during installation work may result in the unit falling and causing accidents.
- Make sure that a separate power supply circuit is provided for this unit and that all electrical work is carried out by qualified personnel according to local laws and regulations and this installation manual. An insufficient power supply capacity or improper electrical construction may lead to electric shocks or fire.
- Be sure to switch off the unit before touching any electrical parts.
- Make sure that all wiring is secured, the specified wires are used, and that there is no strain on the terminal connections or wires.
- If refrigerant gas leaks during installation, ventilate the area immediately.
Toxic gas may be produced if the refrigerant gas comes into contact with fire.
- Make sure to be materials in a compartment handling air for circulation through a duct supplying only one room.
- Do not store or use flammable gas or combustibles near the unit.
 - There is risk of fire, explosion, and physical injury or death.

- Do not use means to accelerate the defrosting process or to clean, other than those recommended by the manufacturer.
- The appliance shall be stored in a room without continuously operating ignition sources (For example: open flames, an operating gas appliance or an operating electric heater.)
- Do not pierce or burn.
- Be aware that refrigerants may not contain an odour.
- The manufacturer may provide other suitable examples or may provide additional information about the refrigerant odour.
- Pipe-work including piping material, pipe routing, and installation shall include protection from physical damage in operation and service, and be in compliance with national and local codes and standards, such as ASHRAE 15, ASHRAE 15.2, IAPMO Uniform Mechanical Code, ICC International Mechanical Code, or CSA B52. All field joints shall be accessible for inspection prior to being covered or enclosed.
- An unventilated area where the appliance using flammable refrigerants is installed shall be so constructed that should any refrigerant leak, it will not stagnate so as to create a fire or explosion hazard.
- Field-made refrigerant joints indoors shall be tightness tested. The test method shall have a sensitivity of 5 grams per year of refrigerant or better under a pressure of at least 0,25 times the maximum allowable pressure. No leak shall be detected;
- If appliances connected via an air duct system to one or more rooms with A2L REFRIGERANTS are installed in a room with an area less than Amin as determined in standard, that room shall be without continuously operating open flames (e.g. an operating gas appliance) or other POTENTIAL IGNITION SOURCES (for e.g., an operating electric heater, hot surfaces). A flame-producing device may be installed in the same space if the device is provided with an effective flame arrest.
- After completion of field piping for split systems, the field pipework shall be pressure tested with an inert gas and then vacuum tested prior to refrigerant charging, according to the following requirements:
 - The minimum test pressure for the low side of the system shall be the low side design pressure and the minimum test pressure for the high side of the system shall be the high side design pressure, unless the high side of the system, cannot be isolated from the low side of the system in which case the entire system shall be pressure tested to the low side design pressure.
 - The test pressure after removal of pressure source shall be maintained for at least 1 h with no decrease of pressure indicated by the test gauge, with test gauge resolution not exceeding 5% of the test pressure.
 - During the evacuation test, after achieving a vacuum level specified in the manual or less, the refrigeration system shall be isolated from the vacuum pump and the pressure shall not rise above 1500 microns within 10 min. The vacuum pressure level shall be specified in the manual, and shall be the lessor of 500 microns or the value required for compliance with national and local codes and standards, which may vary between residential, commercial, and industrial buildings.

Qualification of workers

The manual shall contain specific information about the required qualification of the working personnel for maintenance, service and repair operations. Every working procedure that affects safety means shall only be carried out by qualified person by manufacturer.

Examples for such working procedures are:

- Breaking into the refrigerating circuit;
 - Opening of sealed components;
 - Opening of ventilated enclosures.
-
- Refrigerant tubing shall be protected or enclosed to avoid damage.
 - Flexible refrigerant connectors (such as connecting lines between the indoor and outdoor unit) that may be displaced during normal operations shall be protected against mechanical damage.
 - A brazed, welded, or mechanical connection shall be made before opening the valves to permit refrigerant to flow between the refrigerating system parts.
 - Keep any required ventilation openings clear of obstruction.
 - Mechanical connections (mechanical connectors or flared joints) shall be accessible for maintenance purposes.
 - Flexible pipe elements shall be protected against mechanical damage, excessive stress by torsion, or other forces. They should be checked for mechanical damage annually.
 - Protection devices, piping and fittings shall be protected as far as possible against adverse environmental effects, for example, the danger of water collecting and freezing in relief pipes or the accumulation of dirt and debris.
 - Precautions shall be taken to avoid excessive vibration or pulsation to refrigerating piping.
 - Piping in refrigerating systems shall be so designed and installed to minimize the likelihood hydraulic shock damaging the system.
 - Provision shall be made for expansion and contraction of long runs of piping.
 - Steel pipes and components shall be protected against corrosion with a rustproof coating before applying any insulation.
 - Ducts connected to an appliance shall not contain a potential ignition source.
 - The supply and return air shall be directly ducted to the space.
 - Open areas such as false ceilings shall not be used as a return air duct.
 - Only auxiliary devices approved by the appliance manufacturer or declared suitable with the refrigerant shall be installed in connecting ductwork.
 - Auxiliary devices which can be potential ignition source shall not be installed in connecting ductwork. Examples of potential ignition sources are UV lights, electric heaters with a temperature exceeding 700 °C, pilot flames, brushed motors and similar devices.
 - For duct connected appliances, false ceilings or drop ceilings may be used as a return air plenum if a REFRIGERANT DETECTION SYSTEM is provided in the appliance and any external connections are also provided with a sensor immediately below the return air plenum duct joint.

Wiring

- High voltage electricity is required to operate this system. Adhere to applicable building codes: National Electrical Code (NEC) for U.S. and Mexico, Canada Electrical Code (CE) for Canada and these instructions when wiring.
 - Improper connections and inadequate grounding can cause accidental injury or death.
- Always ground the unit following local, state, and national Codes.
 - There is risk of fire, electric shock, and physical injury or death.
- Properly size all circuit breakers or fuses.
 - There is risk of fire, electric shock, explosion, physical injury or death.
- The information contained in this manual is intended for use by an industry-qualified, experienced, certified electrician familiar with NEC for U.S. and Mexico, or CE for Canada who is equipped with the proper tools and test instruments.
 - Failure to carefully read and follow all instructions in this manual can result in equipment malfunction, property damage, personal injury or death.
- Refer to local, state, and federal codes, and use power wires of sufficient current capacity and rating.
 - Wires that are too small may generate heat and cause a fire.
- All electric work must be performed by a licensed electrician and conform to local building codes or, in the absence of local codes, with NEC for U.S. and Mexico, or CE for Canada, and the instructions given in this manual.
 - If the power source capacity is inadequate or the electric work is not performed properly, it may result in fire, electric shock, physical injury or death.
- Secure all field wiring connections with appropriate wire strain relief.
 - Improperly securing wires will create undue stress on equipment power lugs. Inadequate connections may generate heat, cause a fire and physical injury or death.
- Properly tighten all power lugs.
 - Loose wiring may overheat at connection points, causing a fire, physical injury or death.
- ⓧ Do not change the settings of the protection devices.
 - If the pressure switch, thermal switch, or other protection devices are bypassed or forced to work improperly, or parts other than those specified by LG are used, there is risk of fire, electric shock, explosion, and physical injury or death.
- The appliance shall be installed in accordance with national wiring regulations.
- Means for disconnection must be incorporated in the fixed wiring in accordance with the wiring rules.
- If the supply cord is damaged, it must be replaced by the manufacturer, its service agent or similarly qualified persons in order to avoid a hazard.

NOTE

ⓧ Do not supply power to the unit until all electrical wiring, controls wiring, piping, installation, and refrigerant system evacuation are completed.

Operation

- Unplug the unit if strange sounds, smell, or smoke comes from it.
 - Otherwise, it may cause electrical shock or a fire.
- Keep the flames away.
 - Otherwise, it may cause a fire.
- Take the power plug out if necessary, holding the head of the plug and do not touch it with wet hands.
 - Otherwise, it may cause a fire or electrical shock.
- Do not open the suction inlet of the indoor/outdoor unit during operation.
 - Otherwise, it may electrical shock and failure.
- Do not allow water to run into electrical parts.
 - Otherwise, it may cause the failure of machine or electrical shock.
- Never touch the metal parts of the unit when removing the filter.
 - They are sharp and may cause injury.
- Do not step on the indoor/outdoor unit and do not put anything on it.
 - It may cause an injury through dropping of the unit or falling down.
- When the product is submerged into water, always contact the service center.
 - Otherwise, it may cause a fire or electrical shock.
- Take care so that children may not step on the outdoor unit.
 - Otherwise, children may be seriously injured due to falling down.
- The appliance shall be stored so as to prevent mechanical damage from occurring.
- This appliance is not intended for use by persons (including children) with reduced physical, sensory or mental capabilities or lack of experience and knowledge, unless they have been given supervision or instruction concerning use of the appliance by a person responsible for their safety. Children should be supervised to ensure that they do not play with the appliance.
- LEAK DETECTION SYSTEM installed. Unit must be powered except for service. This unit is equipped with a refrigerant leak detector for safety. To be effective, the unit must be electrically powered at all times after installation, other than when servicing. (LEAK DETECTION SYSTEM can be installed optionally for the safety purpose.)

Service & Installation

Checks to the area

Prior to beginning work on systems containing flammable refrigerants, safety checks are necessary to ensure that the risk of ignition is minimised. For repair to the refrigerating system, the following precautions shall be complied with prior to conducting work on the system.

Work procedure

Work shall be undertaken under a controlled procedure so as to minimise the risk of a flammable gas or vapour being present while the work is being performed.

General work area

All maintenance staff and others working in the local area shall be instructed on the nature of work being carried out. Work in confined spaces shall be avoided.

Checking for presence of refrigerant

The area shall be checked with an appropriate refrigerant detector prior to and during work, to ensure the technician is aware of potentially flammable atmospheres. Ensure that the leak detection equipment being used is suitable for use with flammable refrigerants, i.e. non-sparking, adequately sealed or intrinsically safe.

Presence of fire extinguisher

If any hot work is to be conducted on the refrigerating equipment or any associated parts, appropriate fire extinguishing equipment shall be available to hand. Have a dry powder or CO₂ fire extinguisher adjacent to the charging area.

No ignition sources

No person carrying out work in relation to a refrigerating system which involves exposing any pipe work shall use any sources of ignition in such a manner that it may lead to the risk of fire or explosion.

All possible ignition sources, including cigarette smoking, should be kept sufficiently far away from the site of installation, repairing, removing and disposal, during which refrigerant can possibly be released to the surrounding space. Prior to work taking place, the area around the equipment is to be surveyed to make sure that there are no flammable hazards or ignition risks. "No Smoking" signs shall be displayed.

Ventilated area

Ensure that the area is in the open or that it is adequately ventilated before breaking into the system or conducting any hot work. A degree of ventilation shall continue during the period that the work is carried out.

The ventilation should safely disperse any released refrigerant and preferably expel it externally into the atmosphere.

Checks to the refrigerating equipment

Where electrical components are being changed, they shall be fit for the purpose and to the correct specification.

At all times the manufacturer's maintenance and service guidelines shall be followed. If in doubt consult the manufacturer's technical department for assistance.

The following checks shall be applied to installations using flammable refrigerants:

- The actual refrigerant charge is in accordance with the room size within which the refrigerant containing parts are installed
- The ventilation machinery and outlets are operating adequately and are not obstructed
- If an indirect refrigerating circuit is being used, the secondary circuit shall be checked for the presence of refrigerant
- Marking to the equipment continues to be visible and legible. Markings and signs that are illegible shall be corrected
- Refrigerating pipe or components are installed in a position where they are unlikely to be exposed to any substance which may corrode refrigerant containing components, unless the components are constructed of materials which are inherently resistant to being corroded or are suitably protected against being so corroded.

Checks to electrical devices

Repair and maintenance to electrical components shall include initial safety checks and component inspection procedures. If a fault exists that could compromise safety, then no electrical supply shall be connected to the circuit until it is satisfactorily dealt with. If the fault cannot be corrected immediately but it is necessary to continue operation, an adequate temporary solution shall be used. This shall be reported to the owner of the equipment so all parties are advised.

Initial safety checks shall include:

- Capacitors are discharged: this shall be done in a safe manner to avoid possibility of sparking.
- No live electrical components and wiring are exposed while charging, recovering or purging the system.
- Continuity of earth bonding

Repairs to sealed components

Sealed electrical components shall be replaced.

Repair to intrinsically safe components

Intrinsically safe components must be replaced.

Cabling

Check that cabling will not be subject to wear, corrosion, excessive pressure, vibration, sharp edges or any other adverse environmental effects. The check shall also take into account the effects of aging or continual vibration from sources such as compressors or fans.

Detection of flammable refrigerants

Under no circumstances shall potential sources of ignition be used in the searching for or detection of refrigerant leaks. A halide torch (or any other detector using a naked flame) shall not be used.

Leak detection methods

The following leak detection methods are deemed acceptable for all refrigerant systems.

Electronic leak detectors may be used to detect refrigerant leaks but, in the case of FLAMMABLE REFRIGERANTS, the sensitivity may not be adequate, or may need re-calibration. (Detection equipment shall be calibrated in a refrigerant-free area.) Ensure that the detector is not a potential source of ignition and is suitable for the refrigerant used. Leak detection equipment shall be set at a percentage of the LFL of the refrigerant and shall be calibrated to the refrigerant employed, and the appropriate percentage of gas (25 % maximum) is confirmed.

Leak detection fluids are also suitable for use with most refrigerants but the use of detergents containing chlorine shall be avoided as the chlorine may react with the refrigerant and corrode the copper pipe-work.

NOTE

Examples of leak detection fluids are.

- Bubble method.
- Fluorescent method agents.

If a leak is suspected, all naked flames shall be removed / extinguished.

If a leakage of refrigerant is found which requires brazing, all of the refrigerant shall be recovered from the system, or isolated (by means of shut off valves) in a part of the system remote from the leak. Removal of refrigerant shall be according to removal and evacuation procedure.

Removal and evacuation

When breaking into the refrigerant circuit to make repairs – or for any other purpose – conventional procedures shall be used. However, for flammable refrigerants it is important that best practice be followed, since flammability is a consideration.

The following procedure shall be adhered to:

- Safely remove refrigerant following local and national regulations;
- Evacuate;
- Purge the circuit with inert gas (optional for A2L);
- Evacuate (optional for A2L);
- Continuously flush or purge with inert gas when using flame to open circuit; and
- Open the circuit.

The refrigerant charge shall be recovered into the correct recovery cylinders if venting is not allowed by local and national codes. For appliances containing flammable refrigerants, the system shall be purged with oxygen-free nitrogen to render the appliance safe for flammable refrigerants. This process might need to be repeated several times.

Compressed air or oxygen shall not be used for purging refrigerant systems.

For appliances containing flammable refrigerants, refrigerants purging shall be achieved by breaking the vacuum in the system with oxygen-free nitrogen and continuing to fill until the working pressure is achieved, then venting to atmosphere, and finally pulling down to a vacuum (optional for A2L). This process shall be repeated until no refrigerant is within the system (optional for A2L). When the final oxygen-free nitrogen charge is used, the system shall be vented down to atmospheric pressure to enable work to take place.

The outlet for the vacuum pump shall not be close to any potential ignition sources, and ventilation shall be available.

Charging procedures

In addition to conventional charging procedures, the following requirements shall be followed.

- Ensure that contamination of different refrigerants does not occur when using charging equipment. Hoses or lines shall be as short as possible to minimise the amount of refrigerant contained in them.
- Cylinders shall be kept in an appropriate position according to the instruction.
- Ensure that the refrigerating system is earthed prior to charging the system with refrigerant.
- Label the system when charging is complete (if not already).
- Extreme care shall be taken not to overfill the refrigerating system.

Prior to recharging the system, it shall be pressure tested with the appropriate purging gas.

The system shall be leak-tested on completion of charging but prior to commissioning. A follow up leak test shall be carried out prior to leaving the site.

Decommissioning

Before carrying out this procedure, it is essential that the technician is completely familiar with the equipment and all its detail.

It is recommended good practice that all refrigerants are recovered safely.

Prior to the task being carried out, an oil and refrigerant sample shall be taken in case analysis is required prior to re-use of recovered refrigerant.

It is essential that electrical power is available before the task is commenced.

- a) Become familiar with the equipment and its operation.
- b) Isolate system electrically.
- c) Before attempting the procedure ensure that:
 - Mechanical handling equipment is available, if required, for handling refrigerant cylinders
 - All personal protective equipment is available and being used correctly
 - The recovery process is supervised at all times by a competent person
 - Recovery equipment and cylinders conform to the appropriate standards.
- d) Pump down refrigerant system, if possible.
- e) If a vacuum is not possible, make a manifold so that refrigerant can be removed from various parts of the system.
- f) Make sure that cylinder is situated on the scales before recovery takes place.
- g) Start the recovery machine and operate in accordance with instructions.

- h) Do not overfill cylinders. (No more than 80 % volume liquid charge).
- i) Do not exceed the maximum working pressure of the cylinder, even temporarily.
- j) When the cylinders have been filled correctly and the process completed, make sure that the cylinders and the equipment are removed from site promptly and all isolation valves on the equipment are closed off.
- k) Recovered refrigerant shall not be charged into another refrigerating system unless it has been cleaned and checked.

Labelling

Equipment shall be labelled stating that it has been de-commissioned and emptied of refrigerant. The label shall be dated and signed.

Ensure that there are labels on the equipment stating the equipment contains flammable refrigerant.

Recovery

When removing refrigerant from a system, either for servicing or decommissioning, it is recommended good practice that all refrigerants are removed safely.

When transferring refrigerant into cylinders, ensure that only appropriate refrigerant recovery cylinders are employed.

Ensure that the correct number of cylinders for holding the total system charge is available.

All cylinders to be used are designated for the recovered refrigerant and labelled for that refrigerant (i.e. special cylinders for the recovery of refrigerant).

Cylinders shall be complete with pressure-relief valve and associated shut-off valves in good working order.

Empty recovery cylinders are evacuated and, if possible, cooled before recovery occurs.

The recovery equipment shall be in good working order with a set of instructions concerning the equipment that is at hand and shall be suitable for the recovery of the flammable refrigerant.

If in doubt, the manufacturer should be consulted. In addition, a set of calibrated weighing scales shall be available and in good working order.

Hoses shall be complete with leak-free disconnect couplings and in good condition.

The recovered refrigerant shall be processed according to local legislation in the correct recovery cylinder, and the relevant waste transfer note arranged.

Do not mix refrigerants in recovery units and especially not in cylinders.

If compressor or compressor oils are to be removed, ensure that they have been evacuated to an acceptable level to make certain that flammable refrigerant does not remain within the lubricant.

The compressor body shall not be heated by an open flame or other ignition sources to accelerate this process.

When oil is drained from a system, it shall be carried out safely.

CAUTION

Installation

- Install the drain hose to ensure that drain can be securely done.
 - Otherwise, it may cause water leakage.
- Install the product so that the noise or hot wind from the outdoor unit may not cause any damage to the neighbors.
 - Otherwise, it may cause dispute with the neighbors.
- Always inspect gas leakage after the installation and repair of product.
 - Otherwise, it may cause the failure of product.
- Keep level parallel in installing the product.
 - Otherwise, it may cause vibration or water leakage.
- Do not install the unit in potentially explosive atmospheres.
- The installation of pipe-work shall be kept to a minimum.
- Any person who is involved with working on or breaking into a refrigerant circuit should hold a current valid certificate from an industry-accredited assessment authority, which authorises their competence to handle refrigerants safely in accordance with an industry recognised assessment specification.
- When mechanical connectors are reused indoors, sealing parts shall be renewed.
- When flared joints are reused indoors, the flare part shall be re-fabricated.

Operation

- Avoid excessive cooling and perform ventilation sometimes.
 - Otherwise, it may do harm to your health.
- Use a soft cloth to clean. Do not use wax, thinner, or a strong detergent.
 - The appearance of the air conditioner may deteriorate, change color, or develop surface flaws.
- Do not use an appliance for special purposes such as preserving animals vegetables, precision machine, or art articles.
 - Otherwise, it may damage your properties.
- Do not place obstacles around the flow inlet or outlet.
 - Otherwise, it may cause the failure of appliance or an accident.
- This appliance is not intended for the purposes of cooling INFORMATION TECHNOLOGY EQUIPMENT
- Servicing shall only be performed as recommended by the equipment manufacturer. Maintenance and repair requiring the assistance of other skilled personnel shall be carried out under the supervision of the person competent in the use of flammable refrigerants.

Service

- Servicing shall be performed only as recommended by the manufacturer.

TABLE OF CONTENTS

2 TIPS FOR SAVING ENERGY

3 SAFETY INSTRUCTIONS

16 MINIMUM FLOOR AREA

- 16 UL 60335-2-40:2019 Edition 3
- 19 UL 60335-2-40:2022 Edition 4
- 22 Minimum floor area for ETRS unit(UL 60335-2-40:2022 Edition 4)
- 23 Minimum total conditioned room area
- 25 Altitude adjustment

26 INSTALLATION PARTS

27 INSTALLATION

- 28 Ceiling dimension and hanging bolt location
- 29 Indoor Unit Installation
- 31 Air Filter
- 32 Checking the Drainage
- 33 Indoor Unit Drain Piping
- 34 Combination indoor units
- 35 Flaring work
- 36 Connection of piping - Indoor, Outdoor, BD Unit
- 37 Plumbing materials and storage methods
- 39 Heat insulation
- 39 Wiring Connection
- 40 Connection method of the connecting cable(Example)

43 REMOTE CONTROLLER INSTALLATION

- 45 Wired remote controller installation

46 HOW TO SET E.S.P?

- 46 Installer Setting - E.S.P.
- 48 Installer Setting - Auto ESP

49 SELF-DIAGNOSIS FUNCTION

50 DIP SWITCH SETTING

- 50 R32 refrigerant leakage sensor
- 51 Standard 3 wired remote controller
- 51 Wireless remote controller
- 52 Deluxe Wired Remote Controller
- 53 Troubleshooting

MINIMUM FLOOR AREA

UL 60335-2-40:2019 Edition 3

- The appliance shall be installed, operated and stored in a room with a floor area larger than the minimum area.
- Use the table to determine the minimum area.
- m : Total refrigerant amount in the system
- Total refrigerant amount : factory refrigerant charge + additional refrigerant mount
- A_{min} : minimum area for installation

NOTE

- If the opening height of discharge of intake duct outlet is lower than the unit installation height, the installation height is the lower opening height of duct outlet.
- Multi F Indoor units shall not be used in a sealed room without ventilation to the outside of the room.
- Multi F indoor units shall not be installed on the lowest underground floor of the building.

m		Minimum floor Area (Installed Height)									
		A _{min} (≥ 0 m, 0 ft)		A _{min} (≥ 0.8 m, 2.62 ft)		A _{min} (≥ 1.0 m, 3.28 ft)		A _{min} (≥ 1.2 m, 3.94 ft)		A _{min} (≥ 1.4 m, 4.59 ft)	
kg	oz	m ²	ft ²	m ²	ft ²	m ²	ft ²	m ²	ft ²	m ²	ft ²
≤ 1.842	≤ 64.97										
1.843	65.01	40.02	430.79	30.02	323.09	24.01	258.47	20.01	215.40	17.15	184.62
2.00	70.55	43.43	467.49	32.57	350.62	26.06	280.49	21.72	233.74	18.61	200.35
2.20	77.60	47.77	514.24	35.83	385.68	28.66	308.54	23.89	257.12	20.47	220.39
2.40	84.66	52.12	560.99	39.09	420.74	31.27	336.59	26.06	280.49	22.34	240.42
2.60	91.71	57.53	619.28	42.35	455.80	33.88	364.64	28.23	303.87	24.20	260.46
2.80	98.77	62.72	678.22	45.60	490.86	36.48	392.69	30.40	327.24	26.06	280.49
3.00	105.82	67.60	724.49	48.86	525.92	39.09	420.74	32.57	350.62	27.92	300.53
3.20	112.88	72.15	773.08	52.12	560.99	41.69	448.79	34.74	373.99	29.78	320.56
3.40	119.93	76.39	819.01	55.37	596.05	44.30	476.84	36.92	397.36	31.64	340.60
3.60	126.99	80.30	862.60	58.62	631.12	46.91	504.89	39.09	420.74	33.50	360.63
3.80	134.04	84.20	904.24	61.87	666.18	49.51	532.94	41.26	444.11	35.37	380.67
4.00	141.10	88.11	944.01	65.12	701.24	52.12	560.99	43.43	467.49	37.23	400.70
4.20	148.15	92.00	981.00	68.37	736.30	54.72	589.03	45.60	490.86	39.09	420.74
4.40	155.21	95.87	1016.27	71.62	771.36	57.32	617.08	47.77	514.24	40.95	440.77
4.60	162.26	99.72	1050.00	74.87	806.42	60.00	645.13	49.95	537.61	42.81	460.81
4.80	169.32	103.59	1083.00	78.12	841.48	62.60	673.18	52.12	560.99	44.67	480.84
5.00	176.37	107.43	1115.00	81.37	876.54	65.21	701.24	54.29	584.36	46.53	500.88
5.20	183.42	111.28	1146.00	84.62	911.60	67.81	731.30	56.46	607.69	48.39	520.92
5.40	190.48	115.12	1176.00	87.87	946.66	70.41	761.36	58.63	631.02	50.26	540.95
5.60	197.53	118.97	1205.00	91.12	981.72	73.01	791.42	60.80	654.33	52.12	560.99
5.80	204.59	122.81	1233.00	94.37	1016.78	75.61	821.48	63.17	677.64	53.98	581.02
6.00	211.64	126.66	1260.00	97.62	1051.84	78.21	851.54	65.54	701.24	55.84	601.06
6.20	218.70	130.50	1287.00	100.87	1086.90	80.81	881.60	67.92	725.55	57.69	621.09
6.40	225.75	134.35	1314.00	104.12	1121.96	83.41	911.66	70.29	750.00	59.55	641.13
6.60	232.81	138.19	1341.00	107.37	1157.02	86.01	941.72	72.66	774.31	61.41	661.16
6.80	239.86	142.04	1368.00	110.62	1192.08	88.61	971.78	75.03	800.00	63.26	681.19
7.00	246.92	145.88	1395.00	113.87	1227.14	91.21	1001.84	77.40	824.31	65.12	701.24
7.20	253.97	149.73	1422.00	117.12	1262.20	93.81	1031.90	79.77	848.62	66.97	721.27
7.40	261.03	153.57	1449.00	120.37	1297.26	96.41	1061.96	82.14	872.93	68.83	741.30
7.60	268.08	157.42	1476.00	123.62	1332.32	99.01	1092.02	84.51	897.24	70.68	761.33
7.80	275.14	161.26	1503.00	126.87	1367.38	101.61	1122.08	86.88	921.55	72.54	781.36
8.00	282.19	165.11	1530.00	130.12	1402.44	104.21	1152.14	89.25	945.86	74.39	801.39
8.20	289.25	168.95	1557.00	133.37	1437.50	106.81	1182.20	91.62	970.17	76.25	821.42
8.40	296.30	172.80	1584.00	136.62	1472.56	109.41	1212.26	94.00	994.48	78.10	841.45
8.60	303.36	176.64	1611.00	139.87	1507.62	112.01	1242.32	96.37	1018.79	79.96	861.48
8.80	310.41	180.49	1638.00	143.12	1542.68	114.61	1272.38	98.74	1043.10	81.81	881.51
9.00	317.47	184.33	1665.00	146.37	1577.74	117.21	1302.44	101.11	1067.41	83.67	901.54
9.20	324.52	188.18	1692.00	149.62	1612.80	119.81	1332.50	103.48	1091.72	85.52	921.57
9.40	331.58	192.02	1719.00	152.87	1647.86	122.41	1362.56	105.85	1116.03	87.38	941.60
9.60	338.63	195.87	1746.00	156.12	1682.92	125.01	1392.62	108.22	1140.34	89.23	961.63
9.80	345.68	199.71	1773.00	159.37	1717.98	127.61	1422.68	110.59	1164.65	91.09	981.66
10.00	352.74	203.56	1800.00	162.62	1753.04	130.21	1452.74	112.96	1188.96	92.94	1001.69
10.20	359.79	207.40	1827.00	165.87	1788.10	132.81	1482.80	115.33	1213.27	94.79	1021.72
10.40	366.85	211.25	1854.00	169.12	1823.16	135.41	1512.86	117.70	1237.58	96.64	1041.75
10.60	373.90	215.09	1881.00	172.37	1858.22	138.01	1542.92	120.07	1261.89	98.49	1061.78
10.80	380.96	218.93	1908.00	175.62	1893.28	140.61	1572.98	122.44	1286.20	100.34	1081.81
11.00	388.01	222.78	1935.00	178.87	1928.34	143.21	1603.04	124.81	1310.51	102.19	1101.84
11.20	395.07	226.62	1962.00	182.12	1963.40	145.81	1633.10	127.18	1334.82	104.04	1121.87
11.40	402.12	230.47	1989.00	185.37	1998.46	148.41	1663.16	129.55	1359.13	105.89	1141.90
11.60	409.18	234.31	2016.00	188.62	2033.52	151.01	1693.22	131.92	1383.44	107.74	1161.93
11.80	416.23	238.16	2043.00	191.87	2068.58	153.61	1723.28	134.29	1407.75	109.59	1181.96
12.00	423.29	242.00	2070.00	195.12	2103.64	156.21	1753.34	136.66	1432.06	111.44	1201.99
12.20	430.34	245.85	2097.00	198.37	2138.70	158.81	1783.40	139.03	1456.37	113.29	1222.02
12.40	437.40	249.69	2124.00	201.62	2173.76	161.41	1813.46	141.40	1480.68	115.14	1242.05
12.60	444.45	253.54	2151.00	204.87	2208.82	164.01	1843.52	143.77	1504.99	116.99	1262.08
12.80	451.51	257.38	2178.00	208.12	2243.88	166.61	1873.58	146.14	1529.30	118.84	1282.11
13.00	458.56	261.23	2205.00	211.37	2278.94	169.21	1903.64	148.51	1553.61	120.69	1302.14
13.20	465.62	265.07	2232.00	214.62	2314.00	171.81	1933.70	150.88	1577.92	122.54	1322.17
13.40	472.67	268.92	2259.00	217.87	2349.06	174.41	1963.76	153.25	1602.23	124.39	1342.20
13.60	479.73	272.76	2286.00	221.12	2384.12	177.01	1993.82	155.62	1626.54	126.24	1362.23
13.80	486.78	276.60	2313.00	224.37	2419.18	179.61	2023.88	157.99	1650.85	128.09	1382.26
14.00	493.84	280.45	2340.00	227.62	2454.24	182.21	2053.94	160.36	1675.16	129.94	1402.29
14.20	500.89	284.29	2367.00	230.87	2489.30	184.81	2084.00	162.73	1700.00	131.79	1422.32
14.40	507.95	288.14	2394.00	234.12	2524.36	187.41	2114.06	165.10	1724.31	133.64	1442.35
14.60	515.00	291.98	2421.00	237.37	2559.42	190.01	2144.12	167.47	1748.62	135.49	1462.38
14.80	522.06	295.83	2448.00	240.62	2594.48	192.61	2174.18	169.84	1772.93	137.34	1482.41
15.00	529.11	299.67	2475.00	243.87	2629.54	195.21	2204.24	172.21	1797.24	139.19	1502.44
15.20	536.16	303.52	2502.00	247.12	2664.60	197.81	2234.30	174.58	1821.55	141.04	1522.47
15.40	543.22	307.36	2529.00	250.37	2699.66	200.41	2264.36	176.95	1845.86	142.89	1542.50
15.60	550.27	311.21	2556.00	253.62	2734.72	203.01	2294.42	179.32	1870.17	144.74	1562.53
15.80	557.33	315.05	2583.00	256.87	2769.78	205.61	2324.48	181.69	1894.48	146.59	1582.56
15.96	563.11	318.98	2616.00	261.12	2814.84	208.21	2369.54	186.44	1944.54	149.84	1627.62

m		Minimum floor area (Installed Height)							
		A _{min} (≥ 1.6 m, 5.25 ft)		A _{min} (≥ 1.8 m, 5.91 ft)		A _{min} (≥ 2.0 m, 6.56 ft)		A _{min} (≥ 2.2 m, 7.22 ft)	
kg	oz	m ²	ft ²	m ²	ft ²	m ²	ft ²	m ²	ft ²
≤ 1.842	≤ 64.97	-	-	-	-	-	-	-	-
1.843	65.01	15.01	161.55	13.34	143.6	12.01	129.24	10.92	117.49
2.00	70.55	16.29	175.31	14.48	155.83	13.03	140.25	11.84	127.50
2.20	77.60	17.92	192.84	15.92	171.41	14.33	154.27	13.03	140.25
2.40	84.66	19.54	210.37	17.37	187.00	15.64	168.30	14.21	153.00
2.60	91.71	21.17	227.90	18.82	202.58	16.94	182.32	15.40	165.75
2.80	98.77	22.80	245.43	20.27	218.16	18.24	196.34	16.58	178.50
3.00	105.82	24.43	262.96	21.72	233.74	19.54	210.37	17.77	191.25
3.20	112.88	26.06	280.49	23.16	249.33	20.85	224.39	18.95	203.99
3.40	119.93	27.69	298.02	24.61	264.91	22.15	238.42	20.14	216.74
3.60	126.99	29.32	315.55	26.06	280.49	23.45	252.44	21.32	229.49
3.80	134.04	30.94	333.09	27.51	296.08	24.76	266.47	22.51	242.24
4.00	141.10	32.57	350.62	28.95	311.66	26.06	280.49	23.69	254.99
4.20	148.15	34.20	368.15	30.40	327.24	27.36	294.52	24.87	267.74
4.40	155.21	35.83	385.68	31.85	342.82	28.66	308.54	26.06	280.49
4.60	162.26	37.46	403.21	33.30	358.41	29.97	322.57	27.24	293.24
4.80	169.32	39.09	420.74	34.74	373.99	31.27	336.59	28.43	305.99
5.00	176.37	40.72	438.27	36.19	389.57	32.57	350.62	29.61	318.74
5.20	183.42	42.35	455.80	37.64	405.16	33.88	364.64	30.80	331.49
5.40	190.48	43.97	473.33	39.09	420.74	35.18	378.67	31.98	344.24
5.60	197.53	45.60	490.86	40.54	436.32	36.48	392.69	33.17	356.99
5.80	204.59	47.23	508.39	41.98	451.91	37.79	406.71	34.35	369.74
6.00	211.64	48.86	525.92	43.43	467.49	39.09	420.74	35.53	382.49
6.20	218.70	50.49	543.45	44.88	483.07	40.39	434.76	36.72	395.24
6.40	225.75	52.12	560.99	46.33	498.65	41.69	448.79	37.90	407.99
6.60	232.81	53.75	578.52	47.77	514.24	43.00	462.81	39.09	420.74
6.80	239.86	55.37	596.05	49.22	529.82	44.30	476.84	40.27	433.49
7.00	246.92	56.94	613.58	50.67	545.40	45.60	490.86	41.46	446.24
7.20	253.97	58.57	631.11	52.12	560.99	46.91	504.89	42.64	458.99
7.40	261.03	60.20	648.64	53.56	576.57	48.21	518.91	43.83	471.74
7.60	268.08	61.83	666.17	55.01	592.15	49.51	532.94	45.01	484.49
7.80	275.14	63.46	683.70	56.46	607.74	50.81	546.96	46.19	497.24
8.00	282.19	65.09	701.23	57.91	623.32	52.12	560.99	47.38	509.99
8.20	289.25	66.72	718.76	59.36	638.91	53.42	575.01	48.56	522.74
8.40	296.30	68.35	736.29	60.81	654.50	54.72	589.03	49.75	535.49
8.60	303.36	69.98	753.82	62.26	670.09	56.02	603.05	50.93	548.24
8.80	310.41	71.61	771.35	63.71	685.68	57.32	617.07	52.12	560.99
9.00	317.47	73.24	788.88	65.16	701.27	58.62	631.09	53.30	573.74
9.20	324.52	74.87	806.41	66.61	716.86	60.00	645.11	54.49	586.49
9.40	331.58	76.50	823.94	68.06	732.45	61.39	659.13	55.67	600.00
9.60	338.63	78.13	841.47	69.51	748.04	62.78	673.15	56.86	613.74
9.80	345.68	79.76	859.00	70.96	763.63	64.17	687.17	58.04	627.49
10.00	352.74	81.39	876.53	72.41	779.22	65.56	701.19	59.23	641.24
10.20	359.79	83.02	894.06	73.86	794.81	66.95	715.21	60.41	654.99
10.40	366.85	84.65	911.59	75.31	810.40	68.34	729.23	61.60	668.74
10.60	373.90	86.28	929.12	76.76	826.00	69.73	743.25	62.78	682.49
10.80	380.96	87.91	946.65	78.21	841.59	71.12	757.27	63.97	696.24
11.00	388.01	89.54	964.18	79.66	857.18	72.51	771.29	65.15	710.00
11.20	395.07	91.17	981.71	81.11	872.77	73.90	785.31	66.34	723.74
11.40	402.12	92.80	1000.00	82.56	888.36	75.29	799.33	67.53	737.49
11.60	409.18	94.43	1018.29	84.01	903.95	76.68	813.35	68.71	751.24
11.80	416.23	96.06	1036.58	85.46	919.54	78.07	827.37	69.90	764.99
12.00	423.29	97.69	1054.87	86.91	935.13	79.46	841.39	71.08	778.74
12.20	430.34	99.32	1073.16	88.36	950.72	80.85	855.41	72.27	792.49
12.40	437.40	100.95	1091.45	89.81	966.31	82.24	869.43	73.45	806.24
12.60	444.45	102.58	1109.74	91.26	981.90	83.63	883.45	74.64	820.00
12.80	451.51	104.21	1128.03	92.71	997.49	85.02	897.47	75.82	833.74
13.00	458.56	105.84	1146.32	94.16	1013.08	86.41	911.49	77.01	847.49
13.20	465.62	107.47	1164.61	95.61	1028.67	87.80	925.51	78.20	861.24
13.40	472.67	109.10	1182.90	97.06	1044.26	89.19	939.53	79.38	875.00
13.60	479.73	110.73	1201.19	98.51	1059.85	90.58	953.55	80.57	888.74
13.80	486.78	112.36	1219.48	99.96	1075.44	91.97	967.57	81.75	902.49
14.00	493.84	113.99	1237.77	101.41	1091.03	93.36	981.59	82.94	916.24
14.20	500.89	115.62	1256.06	102.86	1106.62	94.75	995.61	84.12	930.00
14.40	507.95	117.25	1274.35	104.31	1122.21	96.14	1009.63	85.31	943.74
14.60	515.00	118.88	1292.64	105.76	1137.80	97.53	1023.65	86.50	957.49
14.80	522.06	120.51	1310.93	107.21	1153.39	98.92	1037.67	87.68	971.24
15.00	529.11	122.14	1329.22	108.66	1168.98	100.31	1051.69	88.87	985.00
15.20	536.17	123.77	1347.51	110.11	1184.57	101.70	1065.71	90.05	998.74
15.40	543.22	125.40	1365.80	111.56	1200.16	103.09	1079.73	91.24	1012.49
15.60	550.27	127.03	1384.09	113.01	1215.75	104.48	1093.75	92.42	1026.24
15.80	557.33	128.66	1402.38	114.46	1231.34	105.87	1107.77	93.61	1040.00
15.96	563.11	130.00	1420.67	115.91	1246.93	107.26	1121.79	94.79	1053.74

UL 60335-2-40:2022 Edition 4

- The appliance shall be installed, operated and stored in a room with a floor area larger than the minimum area.
- Use the table to determine the minimum area.
- m : Total refrigerant amount in the system
- Total refrigerant amount : factory refrigerant charge + additional refrigerant amount
- A_{min} : minimum area for installation

NOTE

- If the opening height of discharge of intake duct outlet is lower than the unit installation height, the installation height is the lower opening height of duct outlet.

m		Minimum floor area (Installed Height)									
		A _{min} (≥ 0 m, 0 ft)		A _{min} (≥ 0.8 m, 2.62 ft)		A _{min} (≥ 1.0 m, 3.28 ft)		A _{min} (≥ 1.2 m, 3.94 ft)		A _{min} (≥ 1.4 m, 4.59 ft)	
kg	oz	m ²	ft ²	m ²	ft ²	m ²	ft ²	m ²	ft ²	m ²	ft ²
≤ 1.836	≤ 64.76	-	-	-	-	-	-	-	-	-	-
1.837	64.80	28.96	311.68	16.29	175.32	12.01	129.24	10.01	107.70	8.58	92.31
2.00	70.55	34.32	369.44	19.31	207.81	13.07	140.70	10.89	117.25	9.34	100.50
2.20	77.60	41.53	447.02	23.36	251.45	14.95	160.93	11.98	128.98	10.27	110.55
2.40	84.66	49.42	531.99	27.80	299.25	17.79	191.52	13.07	140.70	11.20	120.60
2.60	91.71	58.00	624.35	32.63	351.20	20.88	224.77	14.50	156.09	12.14	130.65
2.80	98.77	67.27	724.10	37.84	407.31	24.22	260.68	16.82	181.03	13.07	140.70
3.00	105.82	77.22	831.24	43.44	467.57	27.90	299.25	19.31	207.81	14.18	152.68
3.20	112.88	87.86	945.77	49.42	531.99	31.63	340.48	21.97	236.44	16.14	173.71
3.40	119.93	99.19	1067.68	55.79	600.57	35.71	384.37	24.80	266.92	18.22	196.10
3.60	126.99	111.20	1196.99	62.55	673.30	40.03	430.91	27.80	299.25	20.43	219.85
3.80	134.04	123.90	1333.68	69.70	750.19	44.61	480.12	30.98	333.42	22.76	244.96
4.00	141.10	137.29	1477.76	77.22	831.24	49.42	531.99	34.32	369.44	25.22	271.43
4.20	148.15	151.36	1629.23	85.14	916.44	54.49	586.52	37.84	407.31	27.80	299.25
4.40	155.21	166.12	1788.09	93.44	1005.80	59.80	643.71	41.53	447.02	30.51	328.42
4.60	162.26	181.56	1954.34	102.13	1099.32	65.36	703.56	45.39	488.58	33.35	358.96
4.80	169.32	197.70	2127.97	111.20	1196.99	71.17	766.07	49.42	531.99	36.31	390.85
5.00	176.37	214.51	2309.00	120.66	1298.81	77.22	831.24	53.63	577.25	39.40	424.10
5.20	183.42	232.02	2497.41	130.51	1404.80	83.53	899.07	58.00	624.35	42.62	458.71
5.40	190.48	250.21	2693.22	140.74	1514.94	90.07	969.56	62.55	673.30	45.96	494.67
5.60	197.53	269.09	2896.41	151.36	1629.23	96.87	1042.71	67.27	724.10	49.42	531.99
5.80	204.59	288.65	3106.99	162.37	1747.68	103.91	1118.52	72.16	776.75	53.02	570.67
6.00	211.64	308.90	3324.96	173.76	1870.29	111.20	1196.99	77.22	831.24	56.74	610.71
6.20	218.70	329.84	3550.32	185.53	1997.05	118.74	1278.11	82.46	887.58	60.58	652.10
6.40	225.75	351.46	3783.07	197.70	2127.97	126.53	1361.90	87.86	945.77	64.55	694.85
6.60	232.81	373.77	4023.20	210.24	2263.05	134.56	1448.35	93.44	1005.80	68.65	738.96
6.80	239.86	396.76	4270.73	223.18	2402.28	142.83	1537.46	99.19	1067.68	72.87	784.42
7.00	246.92	420.45	4525.64	236.50	2545.67	151.36	1629.23	105.11	1131.41	77.22	831.24
7.20	253.97	444.81	4787.94	250.21	2693.22	160.13	1723.66	111.20	1196.99	81.70	879.42
7.40	261.03	469.87	5057.63	264.30	2844.92	169.15	1820.75	117.47	1264.41	86.30	928.95
7.60	268.08	495.61	5334.71	278.78	3000.78	178.42	1920.50	123.90	1333.68	91.03	979.85
7.80	275.14	522.04	5619.18	293.65	3160.79	187.93	2022.91	130.51	1404.80	95.88	1032.09
8.00	282.19	549.15	5911.04	308.90	3324.96	197.70	2127.97	137.29	1477.76	100.86	1085.70
8.20	289.25	576.95	6210.29	324.54	3493.29	207.70	2235.70	144.24	1552.57	105.97	1140.67
8.40	296.30	605.44	6516.92	340.56	3665.77	217.96	2346.09	151.36	1629.23	111.20	1196.99
8.60	303.36	634.62	6830.95	356.97	3842.41	228.46	2459.14	158.65	1707.74	116.56	1254.66
8.80	310.41	664.48	7152.36	373.77	4023.20	239.21	2574.85	166.12	1788.09	122.05	1313.70
9.00	317.47	695.02	7481.16	390.95	4208.15	250.21	2693.22	173.76	1870.29	127.66	1374.09
9.20	324.52	726.26	7817.35	408.52	4397.26	261.45	2814.25	181.56	1954.34	133.39	1435.84
9.40	331.58	758.18	8160.93	426.47	4590.52	272.94	2937.94	189.54	2040.23	139.26	1498.95
9.60	338.63	790.78	8511.90	444.81	4787.94	284.68	3064.28	197.70	2127.97	145.25	1563.41
9.80	345.68	824.07	8870.26	463.54	4989.52	296.67	3193.29	206.02	2217.56	151.36	1629.23
10.00	352.74	858.05	9236.00	482.65	5195.25	308.90	3324.96	214.51	2309.00	157.60	1696.41
10.20	359.79	892.72	9609.14	502.15	5405.14	321.38	3459.29	223.18	2402.28	163.97	1764.94
10.40	366.85	928.07	9989.66	522.04	5619.18	334.11	3596.28	232.02	2497.41	170.46	1834.84
10.60	373.90	964.11	10377.57	542.31	5837.38	347.08	3735.93	241.03	2594.39	177.08	1906.08
10.80	380.96	1000.83	10772.87	562.97	6059.74	360.30	3878.23	250.21	2693.22	183.83	1978.69
11.00	388.01	1038.24	11175.56	584.01	6286.25	373.77	4023.20	259.56	2793.89	190.70	2052.65
11.20	395.07	1076.34	11585.64	605.44	6516.92	387.48	4170.83	269.09	2896.41	197.70	2127.97
11.40	402.12	1115.13	12003.11	627.26	6751.75	401.45	4321.12	278.78	3000.78	204.82	2204.65
11.60	409.18	1154.60	12427.96	649.46	6990.73	415.65	4474.07	288.65	3106.99	212.07	2282.69
11.80	416.23	1194.75	12860.21	672.05	7233.87	430.11	4629.68	298.69	3215.05	219.44	2362.08
12.00	423.29	1235.60	13299.84	695.02	7481.16	444.81	4787.94	308.90	3324.96	226.95	2442.83
12.20	430.34	1277.13	13746.86	718.38	7732.61	459.77	4948.87	319.28	3436.72	234.57	2524.93
12.40	437.40	1319.34	14201.28	742.13	7988.22	474.96	5112.46	329.84	3550.32	242.33	2608.40
12.60	444.45	1362.24	14663.08	766.26	8247.98	490.41	5278.71	340.56	3665.77	250.21	2693.22
12.80	451.51	1405.83	15132.26	790.78	8511.90	506.10	5447.62	351.46	3783.07	258.21	2779.40
13.00	458.56	1450.11	15608.84	815.69	8779.97	522.04	5619.18	362.53	3902.21	266.35	2866.93
13.20	465.62	1495.07	16092.81	840.98	9052.20	538.23	5793.41	373.77	4023.20	274.60	2955.82
13.40	472.67	1540.72	16584.16	866.65	9328.59	554.66	5970.30	385.18	4146.04	282.99	3046.07
13.60	479.73	1587.05	17082.91	892.72	9609.14	571.34	6149.85	396.76	4270.73	291.50	3137.68
13.80	486.78	1634.08	17589.04	919.17	9893.84	588.27	6332.05	408.52	4397.26	300.14	3230.64
14.00	493.84	1681.78	18102.56	946.00	10182.69	605.44	6516.92	420.45	4524.64	308.90	3324.96
14.20	500.89	1730.18	18623.47	973.22	10475.70	622.86	6704.45	432.54	4655.87	317.79	3420.64
14.40	507.95	1779.26	19151.77	1000.83	10772.87	640.53	6894.64	444.81	4787.94	326.80	3517.67
14.60	515.00	1829.02	19687.46	1028.83	11074.20	658.45	7087.49	457.26	4921.87	335.94	3616.06
14.80	522.05	1879.48	20230.54	1057.21	11379.68	676.61	7282.99	469.87	5057.63	345.21	3715.81
15.00	529.11	1930.62	20781.00	1085.97	11689.31	695.02	7481.16	482.65	5195.25	354.60	3816.92
15.20	536.16	1982.44	21338.86	1115.13	12003.11	713.68	7681.99	495.61	5334.71	364.12	3919.38
15.40	543.22	2034.96	21904.10	1144.66	12321.06	732.58	7885.48	508.74	5476.03	373.77	4023.20
15.60	550.27	2088.16	22476.73	1174.59	12643.16	751.74	8091.62	522.04	5619.18	383.54	4128.38
15.80	557.33	2142.04	23056.75	1204.90	12969.42	771.14	8300.43	535.51	5764.19	393.44	4234.91
15.91	561.28	2172.52	23384.79	1222.04	13153.95	782.11	8418.53	543.13	5846.20	399.03	4295.17

m		Minimum floor area (Installed Height)							
		A _{min} (≥ 1.6 m, 5.25 ft)		A _{min} (≥ 1.8 m, 5.91 ft)		A _{min} (≥ 2.0 m, 6.56 ft)		A _{min} (≥ 2.2 m, 7.22 ft)	
kg	oz	m ²	ft ²	m ²	ft ²	m ²	ft ²	m ²	ft ²
≤ 1.836	≤ 64.76	-	-	-	-	-	-	-	-
1.837	64.80	7.50	80.77	6.67	71.80	6.00	64.62	5.46	58.74
2.00	70.55	8.17	87.94	7.26	78.17	6.54	70.35	5.94	63.96
2.20	77.60	8.99	96.73	7.99	85.99	7.19	77.39	6.54	70.35
2.40	84.66	9.80	105.53	8.71	93.80	7.84	84.42	7.13	76.75
2.60	91.71	10.62	114.32	9.44	101.62	8.50	91.46	7.72	83.14
2.80	98.77	11.44	123.12	10.17	109.44	9.15	98.49	8.32	89.54
3.00	105.82	12.25	131.91	10.89	117.25	9.80	105.53	8.91	95.94
3.20	112.88	13.07	140.70	11.62	125.07	10.46	112.56	9.51	102.33
3.40	119.93	13.95	150.14	12.35	132.89	11.11	119.60	10.10	108.73
3.60	126.99	15.64	168.33	13.07	140.70	11.76	126.63	10.70	115.12
3.80	134.04	17.42	187.55	13.80	148.52	12.42	133.67	11.29	121.52
4.00	141.10	19.31	207.81	15.25	164.20	13.07	140.70	11.88	127.91
4.20	148.15	21.29	229.11	16.82	181.03	13.73	147.74	12.48	134.31
4.40	155.21	23.36	251.45	18.46	198.68	14.95	160.93	13.07	140.70
4.60	162.26	25.53	274.83	20.17	217.15	16.34	175.89	13.67	147.10
4.80	169.32	27.80	299.25	21.97	236.44	17.79	191.52	14.70	158.28
5.00	176.37	30.17	324.70	23.83	256.56	19.31	207.81	15.96	171.74
5.20	183.42	32.63	351.20	25.78	277.49	20.88	224.77	17.26	185.76
5.40	190.48	35.19	378.73	27.80	299.25	22.52	242.39	18.61	200.32
5.60	197.53	37.84	407.31	29.90	321.82	24.22	260.68	20.01	215.44
5.80	204.59	40.59	436.92	32.07	345.22	25.98	279.63	21.47	231.10
6.00	211.64	43.44	467.57	34.32	369.44	27.80	299.25	22.98	247.31
6.20	218.70	46.38	499.26	36.65	394.48	29.69	319.53	24.53	264.07
6.40	225.75	49.42	531.99	39.05	420.34	31.63	340.48	26.14	281.39
6.60	232.81	52.56	565.76	41.53	447.02	33.64	362.09	27.80	299.25
6.80	239.86	55.79	600.57	44.08	474.53	35.71	384.37	29.51	317.66
7.00	246.92	59.13	636.42	46.72	502.85	37.84	407.31	31.27	336.62
7.20	253.97	62.55	673.30	49.42	531.99	40.03	430.91	33.09	356.13
7.40	261.03	66.08	711.23	52.21	561.96	42.29	455.19	34.95	376.19
7.60	268.08	69.70	750.19	55.07	592.75	44.61	480.12	36.86	396.80
7.80	275.14	73.41	790.20	58.00	624.35	46.98	505.73	38.83	417.96
8.00	282.19	77.22	831.24	61.02	656.78	49.42	531.99	40.85	439.66
8.20	289.25	81.13	873.32	64.11	690.03	51.93	558.93	42.91	461.92
8.40	296.30	85.14	916.44	67.27	724.10	54.49	586.52	45.03	484.73
8.60	303.36	89.24	960.60	70.51	758.99	57.12	614.79	47.20	508.09
8.80	310.41	93.44	1005.80	73.83	794.71	59.80	643.71	49.42	531.99
9.00	317.47	97.74	1052.04	77.22	831.24	62.55	673.30	51.70	556.45
9.20	324.52	102.13	1099.32	80.70	868.59	65.36	703.56	54.02	581.46
9.40	331.58	106.62	1147.63	84.24	906.77	68.24	734.48	56.39	607.01
9.60	338.63	111.20	1196.99	87.86	945.77	71.17	766.07	58.82	633.12
9.80	345.68	115.89	1247.38	91.56	985.58	74.17	798.32	61.29	659.77
10.00	352.74	120.66	1298.81	95.34	1026.22	77.22	831.24	63.82	686.98
10.20	359.79	125.54	1351.28	99.19	1067.68	80.34	864.82	66.40	714.73
10.40	366.85	130.51	1404.80	103.12	1109.96	83.53	899.07	69.03	743.03
10.60	373.90	135.58	1459.35	107.12	1153.06	86.77	933.98	71.71	771.89
10.80	380.96	140.74	1514.94	111.20	1196.99	90.07	969.56	74.44	801.29
11.00	388.01	146.00	1571.56	115.36	1241.73	93.44	1005.80	77.22	831.24
11.20	395.07	151.36	1629.23	119.59	1287.29	96.87	1042.71	80.06	861.74
11.40	402.12	156.81	1687.94	123.90	1333.68	100.36	1080.28	82.94	892.79
11.60	409.18	162.37	1747.68	128.29	1380.88	103.91	1118.52	85.88	924.39
11.80	416.23	168.01	1808.47	132.75	1428.91	107.53	1157.42	88.87	956.54
12.00	423.29	173.76	1870.29	137.29	1477.76	111.20	1196.99	91.90	989.24
12.20	430.34	179.60	1933.15	141.90	1527.43	114.94	1237.22	94.99	1022.49
12.40	437.40	185.53	1997.05	146.59	1577.92	118.74	1278.11	98.13	1056.29
12.60	444.45	191.57	2062.00	151.36	1629.23	122.60	1319.68	101.32	1090.64
12.80	451.51	197.70	2127.97	156.20	1681.36	126.53	1361.90	104.57	1125.54
13.00	458.56	203.92	2194.99	161.12	1734.32	130.51	1404.80	107.86	1160.99
13.20	465.62	210.24	2263.05	166.12	1788.09	134.56	1448.35	111.20	1196.99
13.40	472.67	216.66	2332.15	171.19	1842.68	138.66	1492.57	114.60	1233.53
13.60	479.73	223.18	2402.28	176.34	1898.10	142.83	1537.46	118.05	1270.63
13.80	486.78	229.79	2473.46	181.56	1954.34	147.07	1583.01	121.54	1308.28
14.00	493.84	236.50	2545.67	186.86	2011.40	151.36	1629.23	125.09	1346.47
14.20	500.89	243.31	2618.93	192.24	2069.27	155.72	1676.11	128.69	1385.22
14.40	507.95	250.21	2693.22	197.70	2127.97	160.13	1723.66	132.34	1424.51
14.60	515.00	257.21	2768.55	203.22	2187.50	164.61	1771.87	136.04	1464.36
14.80	522.05	264.30	2844.92	208.83	2247.84	169.15	1820.75	139.80	1504.75
15.00	529.11	271.49	2922.33	214.51	2309.00	173.76	1870.29	143.60	1545.69
15.20	536.16	278.78	3000.78	220.27	2370.98	178.42	1920.50	147.45	1587.19
15.40	543.22	286.17	3080.26	226.11	2433.79	183.15	1971.37	151.36	1629.23
15.60	550.27	293.65	3160.79	232.02	2497.41	187.93	2022.91	155.32	1671.82
15.80	557.33	301.22	3242.36	238.00	2561.86	192.78	2075.11	159.33	1714.97
15.91	561.28	305.51	3288.49	241.39	2598.31	195.53	2104.63	161.59	1739.36

Minimum floor area for ETRS unit (UL 60335-2-40:2022 Edition 4)

- The following instructions apply to appliance marked "ETRS" on the nameplate (enhanced tightness refrigerating systems).

- m : Total refrigerant amount in the system

- Total refrigerant amount : factory refrigerant charge + additional refrigerant amount

- A_{min} : minimum area for installation

- Hr : Room height (standard).

If the indoor unit is ETRS, Hr is the room height in meters but not more than 2.2 m

NOTE

- If the appliance is installed less than 1.8 m (5.91 ft), Install REFRIGERANT DETECTION SYSTEM for using the table below or Refer to the table of Minimum floor area (UL 60335-2-40:2022 Edition 4)
- Refer to the R32 sensor accessory manual for wiring and installation, if required.

Minimum floor area			
m		A_{min}	
kg	oz	m ²	ft ²
≤ 1.836	≤ 64.76	-	-
1.837	64.80	5.46	58.74
2.00	70.55	5.94	63.96
2.20	77.60	6.54	70.35
2.40	84.66	7.13	76.75
2.60	91.71	7.72	83.14
2.80	98.77	8.32	89.54
3.00	105.82	8.91	95.94
3.20	112.88	9.51	102.33
3.40	119.93	10.10	108.73
3.60	126.99	10.70	115.12
3.80	134.04	11.29	121.52
4.00	141.10	11.88	127.91
4.20	148.15	12.48	134.31
4.40	155.21	13.07	140.70
4.60	162.26	13.67	147.10
4.80	169.32	14.26	153.50
5.00	176.37	14.85	159.89
5.20	183.42	15.45	166.29
5.40	190.48	16.04	172.68
5.60	197.53	16.64	179.08
5.80	204.59	17.23	185.47
6.00	211.64	17.83	191.87
6.20	218.70	18.42	198.27
6.40	225.75	19.01	204.66
6.60	232.81	19.61	211.06
6.80	239.86	20.20	217.45
7.00	246.92	20.80	223.85
7.20	253.97	21.39	230.24
7.40	261.03	21.98	236.64
7.60	268.08	22.58	243.04
7.80	275.14	23.17	249.43
8.00	282.19	23.77	255.83
8.20	289.25	24.36	262.22
8.40	296.30	24.96	268.62
8.60	303.36	25.55	275.01
8.80	310.41	26.14	281.41

Minimum floor area			
m		A_{min}	
kg	oz	m ²	ft ²
9.00	317.47	26.74	287.81
9.20	324.52	27.33	294.20
9.40	331.58	27.93	300.60
9.60	338.63	28.52	306.99
9.80	345.68	29.11	313.39
10.00	352.74	29.71	319.78
10.20	359.79	30.30	326.18
10.40	366.85	30.90	332.57
10.60	373.90	31.49	338.97
10.80	380.96	32.09	345.37
11.00	388.01	32.68	351.76
11.20	395.07	33.27	358.16
11.40	402.12	33.87	364.55
11.60	409.18	34.46	370.95
11.80	416.23	35.06	377.34
12.00	423.29	35.65	383.74
12.20	430.34	36.24	390.14
12.40	437.40	36.84	396.53
12.60	444.45	37.43	402.93
12.80	451.51	38.03	409.32
13.00	458.56	38.62	415.72
13.20	465.62	39.22	422.11
13.40	472.67	39.81	428.51
13.60	479.73	40.40	434.91
13.80	486.78	41.00	441.30
14.00	493.84	41.59	447.70
14.20	500.89	42.19	454.09
14.40	507.95	42.78	460.49
14.60	515.00	43.37	466.88
14.80	522.05	43.97	473.28
15.00	529.11	44.56	479.68
15.20	536.16	45.16	486.07
15.40	543.22	45.75	492.47
15.60	550.27	46.35	498.86
15.80	557.33	46.94	505.26
15.91	561.28	47.27	508.84

Minimum total conditioned room area

The following instructions apply to appliance marked "ETRS" on the nameplate (enhanced tightness refrigerating systems). When detecting refrigerant leakage, indoor units operate with maximum air flow rate. If maximum air flow rate of ducted indoor unit is more than Q_{min} below table, can use TA_{min} instead A_{min} .

※ Maximum air flow rate of ducted indoor unit is announced in EM or E-SVC Manual spec sheet.
* <KNMKB***A> and <ZRNU**3L*G*> shall be connected to one room.

- m : Total refrigerant amount in the system.
- Total refrigerant amount in the system : factory refrigerant charge + additional refrigerant amount.
- m_{rel} : Maximum Releasable charge when the shut-off valve is installed.
- TA_{min} : minimum total conditioned room area for appliance connected via an air duct system to one or more rooms.
- EM : Engineering Manuals.
- E-SVC Manual : Service Manual (Exploded View)

m or m_{rel}		Q_{min}		TA_{min}	
kg	oz	CMM	CFM	m ²	ft ²
≤ 1.836	≤ 64.76	-	-	-	-
1.837	64.80	3.0	106.0	5.46	58.74
2.00	70.55	3.3	115.4	5.94	63.96
2.20	77.60	3.6	126.9	6.54	70.35
2.40	84.66	3.9	138.5	7.13	76.75
2.60	91.71	4.2	150.0	7.72	83.14
2.80	98.77	4.6	161.5	8.32	89.54
3.00	105.82	4.9	173.1	8.91	95.93
3.20	112.88	5.2	184.6	9.51	102.33
3.40	119.93	5.6	196.2	10.10	108.73
3.60	126.99	5.9	207.7	10.70	115.12
3.80	134.04	6.2	219.2	11.29	121.52
4.00	141.10	6.5	230.8	11.88	127.91
4.20	148.15	6.9	242.3	12.48	134.31
4.40	155.21	7.2	253.9	13.07	140.70
4.60	162.26	7.5	265.4	13.67	147.10
4.80	169.32	7.8	276.9	14.26	153.50
5.00	176.37	8.2	288.5	14.85	159.89
5.20	183.42	8.5	300.0	15.45	166.29
5.40	190.48	8.8	311.6	16.04	172.68
5.60	197.53	9.2	323.1	16.64	179.08
5.80	204.59	9.5	334.6	17.23	185.47
6.00	211.64	9.8	346.2	17.83	191.87
6.20	218.70	10.1	357.7	18.42	198.27
6.40	225.75	10.5	369.3	19.01	204.66
6.60	232.81	10.8	380.8	19.61	211.06
6.80	239.86	11.1	392.3	20.20	217.45
7.00	246.92	11.4	403.9	20.80	223.85
7.20	253.97	11.8	415.4	21.39	230.24
7.40	261.03	12.1	427.0	21.98	236.64
7.60	268.08	12.4	438.5	22.58	243.04
7.80	275.14	12.7	450.0	23.17	249.43
8.00	282.19	13.1	461.6	23.77	255.83
8.20	289.25	13.4	473.1	24.36	262.22
8.40	296.30	13.7	484.6	24.96	268.62
8.60	303.36	14.1	496.2	25.55	275.01
8.80	310.41	14.4	507.7	26.14	281.41
9.00	317.47	14.7	519.3	26.74	287.80
9.20	324.52	15.0	530.8	27.33	294.20

m or m_{rel}		Q_{min}		TA_{min}	
kg	oz	CMM	CFM	m ²	ft ²
9.40	331.58	15.4	542.3	27.93	300.60
9.60	338.63	15.7	553.9	28.52	306.99
9.80	345.69	16.0	565.4	29.11	313.39
10.00	352.74	16.3	577.0	29.71	319.78
10.20	359.79	16.7	588.5	30.30	326.18
10.40	366.85	17.0	600.0	30.90	332.57
10.60	373.90	17.3	611.6	31.49	338.97
10.80	380.96	17.6	623.1	32.09	345.37
11.00	388.01	18.0	634.7	32.68	351.76
11.20	395.07	18.3	646.2	33.27	358.16
11.40	402.12	18.6	657.7	33.87	364.55
11.60	409.18	19.0	669.3	34.46	370.95
11.80	416.23	19.3	680.8	35.06	377.34
12.00	423.29	19.6	692.4	35.65	383.74
12.20	430.34	19.9	703.9	36.24	390.14
12.40	437.40	20.3	715.4	36.84	396.53
12.60	444.45	20.6	727.0	37.43	402.93
12.80	451.51	20.9	738.5	38.03	409.32
13.00	458.56	21.2	750.0	38.62	415.72
13.20	465.62	21.6	761.6	39.22	422.11
13.40	472.67	21.9	773.1	39.81	428.51
13.60	479.73	22.2	784.7	40.40	434.91
13.80	486.78	22.5	796.2	41.00	441.30
14.00	493.84	22.9	807.7	41.59	447.70
14.20	500.89	23.2	819.3	42.19	454.09
14.40	507.95	23.5	830.8	42.78	460.49
14.60	515.00	23.9	842.4	43.37	466.88
14.80	522.06	24.2	853.9	43.97	473.28
15.00	529.11	24.5	865.4	44.56	479.67
15.20	536.16	24.8	877.0	45.16	486.07
15.40	543.22	25.2	888.5	45.75	492.47
15.60	550.27	25.5	900.1	46.35	498.86
15.80	557.33	25.8	911.6	46.94	505.26
16.00	564.38	26.1	923.1	47.53	511.65
16.20	571.44	26.5	934.7	48.13	518.05
16.40	578.49	26.8	946.2	48.72	524.44
16.60	585.55	27.1	957.8	49.32	530.84
16.80	592.60	27.5	969.3	49.91	537.24
17.00	599.66	27.8	980.8	50.51	543.63

24 MINIMUM FLOOR AREA

m or m _{rel}		Q _{min}		TA _{min}	
kg	oz	CMM	CFM	m ²	ft ²
17.20	606.71	28.1	992.4	51.10	550.03
17.40	613.77	28.4	1003.9	51.69	556.42
17.60	620.82	28.8	1015.5	52.29	562.82
17.80	627.88	29.1	1027.0	52.88	569.21
18.00	634.93	29.4	1038.5	53.48	575.61
18.20	641.99	29.7	1050.1	54.07	582.01
18.40	649.04	30.1	1061.6	54.66	588.40
18.60	656.10	30.4	1073.1	55.26	594.80
18.80	663.15	30.7	1084.7	55.85	601.19
19.00	670.21	31.0	1096.2	56.45	607.59
19.20	677.26	31.4	1107.8	57.04	613.98
19.40	684.32	31.7	1119.3	57.64	620.38
19.60	691.37	32.0	1130.8	58.23	626.77
19.80	698.43	32.4	1142.4	58.82	633.17
20.00	705.48	32.7	1153.9	59.42	639.57
20.20	712.53	33.0	1165.5	60.01	645.96
20.40	719.59	33.3	1177.0	60.61	652.36
20.60	726.64	33.7	1188.5	61.20	658.75
20.80	733.70	34.0	1200.1	61.79	665.15
21.00	740.75	34.3	1211.6	62.39	671.54
21.20	747.81	34.6	1223.2	62.98	677.94
21.40	754.86	35.0	1234.7	63.58	684.34
21.60	761.92	35.3	1246.2	64.17	690.73
21.80	768.97	35.6	1257.8	64.77	697.13
22.00	776.03	35.9	1269.3	65.36	703.52
22.20	783.08	36.3	1280.9	65.95	709.92
22.40	790.14	36.6	1292.4	66.55	716.31
22.60	797.19	36.9	1303.9	67.14	722.71
22.80	804.25	37.3	1315.5	67.74	729.11
23.00	811.30	37.6	1327.0	68.33	735.50
23.20	818.36	37.9	1338.5	68.92	741.90
23.40	825.41	38.2	1350.1	69.52	748.29
23.60	832.47	38.6	1361.6	70.11	754.69
23.80	839.52	38.9	1373.2	70.71	761.08
24.00	846.58	39.2	1384.7	71.30	767.48
24.20	853.63	39.5	1396.2	71.90	773.88
24.40	860.69	39.9	1407.8	72.49	780.27
24.60	867.74	40.2	1419.3	73.08	786.67
24.80	874.80	40.5	1430.9	73.68	793.06
25.00	881.85	40.8	1442.4	74.27	799.46
25.20	888.90	41.2	1453.9	74.87	805.85
25.40	895.96	41.5	1465.5	75.46	812.25
25.60	903.01	41.8	1477.0	76.05	818.64
25.80	910.07	42.2	1488.6	76.65	825.04
26.00	917.12	42.5	1500.1	77.24	831.44
26.20	924.18	42.8	1511.6	77.84	837.83
26.40	931.23	43.1	1523.2	78.43	844.23
26.60	938.29	43.5	1534.7	79.03	850.62
26.80	945.34	43.8	1546.3	79.62	857.02
27.00	952.40	44.1	1557.8	80.21	863.41
27.20	959.45	44.4	1569.3	80.81	869.81
27.40	966.51	44.8	1580.9	81.40	876.21
27.60	973.56	45.1	1592.4	82.00	882.60
27.80	980.62	45.4	1604.0	82.59	889.00
28.00	987.67	45.8	1615.5	83.18	895.39
28.20	994.73	46.1	1627.0	83.78	901.79
28.40	1001.78	46.4	1638.6	84.37	908.18
28.60	1008.84	46.7	1650.1	84.97	914.58
28.80	1015.89	47.1	1661.6	85.56	920.98
29.00	1022.95	47.4	1673.2	86.16	927.37
29.20	1030.00	47.7	1684.7	86.75	933.77
29.40	1037.06	48.0	1696.3	87.34	940.16
29.60	1044.11	48.4	1707.8	87.94	946.56
29.80	1051.17	48.7	1719.3	88.53	952.95
30.00	1058.22	49.0	1730.9	89.13	959.35
30.20	1065.27	49.3	1742.4	89.72	965.75
30.40	1072.33	49.7	1754.0	90.31	972.14
30.60	1079.38	50.0	1765.5	90.91	978.54

m or m _{rel}		Q _{min}		TA _{min}	
kg	oz	CMM	CFM	m ²	ft ²
30.80	1086.44	50.3	1777.0	91.50	984.93
31.00	1093.49	50.7	1788.6	92.10	991.33
31.20	1100.55	51.0	1800.1	92.69	997.72
31.40	1107.60	51.3	1811.7	93.29	1004.12
31.60	1114.66	51.6	1823.2	93.88	1010.51
31.80	1121.71	52.0	1834.7	94.47	1016.91
32.00	1128.77	52.3	1846.3	95.07	1023.31
32.20	1135.82	52.6	1857.8	95.66	1029.70
32.40	1142.88	52.9	1869.4	96.26	1036.10
32.60	1149.93	53.3	1880.9	96.85	1042.49
32.80	1156.99	53.6	1892.4	97.45	1048.89
33.00	1164.04	53.9	1904.0	98.04	1055.28
33.20	1171.10	54.2	1915.5	98.63	1061.68
33.40	1178.15	54.6	1927.0	99.23	1068.08
33.60	1185.21	54.9	1938.6	99.82	1074.47
33.80	1192.26	55.2	1950.1	100.42	1080.87
34.00	1199.32	55.6	1961.7	101.01	1087.26
34.20	1206.37	55.9	1973.2	101.60	1093.66
34.40	1213.43	56.2	1984.7	102.20	1100.05
34.60	1220.48	56.5	1996.3	102.79	1106.45
34.80	1227.54	56.9	2007.8	103.39	1112.85
35.00	1234.59	57.2	2019.4	103.98	1119.24
35.20	1241.64	57.5	2030.9	104.58	1125.64
35.40	1248.70	57.8	2042.4	105.17	1132.03
35.60	1255.75	58.2	2054.0	105.76	1138.43
35.80	1262.81	58.5	2065.5	106.36	1144.82
36.00	1269.86	58.8	2077.1	106.95	1151.22
36.20	1276.92	59.2	2088.6	107.55	1157.61
36.40	1283.97	59.5	2100.1	108.14	1164.01
36.60	1291.03	59.8	2111.7	108.73	1170.41
36.80	1298.08	60.1	2123.2	109.33	1176.80
37.00	1305.14	60.5	2134.8	109.92	1183.20
37.20	1312.19	60.8	2146.3	110.52	1189.59
37.40	1319.25	61.1	2157.8	111.11	1195.99
37.60	1326.30	61.4	2169.4	111.71	1202.38
37.80	1333.36	61.8	2180.9	112.30	1208.78
38.00	1340.41	62.1	2192.5	112.89	1215.18
38.20	1347.47	62.4	2204.0	113.49	1221.57
38.40	1354.52	62.7	2215.5	114.08	1227.97
38.60	1361.58	63.1	2227.1	114.68	1234.36
38.80	1368.63	63.4	2238.6	115.27	1240.76
39.00	1375.69	63.7	2250.1	115.86	1247.15
39.20	1382.74	64.1	2261.7	116.46	1253.55
39.40	1389.80	64.4	2273.2	117.05	1259.95
39.60	1396.85	64.7	2284.8	117.65	1266.34
39.80	1403.91	65.0	2296.3	118.24	1272.74
40.00	1410.96	65.4	2307.8	118.84	1279.13
40.20	1418.01	65.7	2319.4	119.43	1285.53
40.40	1425.07	66.0	2330.9	120.02	1291.92
40.60	1432.12	66.3	2342.5	120.62	1298.32
40.80	1439.18	66.7	2354.0	121.21	1304.72
41.00	1446.23	67.0	2365.5	121.81	1311.11
41.20	1453.29	67.3	2377.1	122.40	1317.51
41.40	1460.34	67.6	2388.6	122.99	1323.90
41.60	1467.40	68.0	2400.2	123.59	1330.30
41.80	1474.45	68.3	2411.7	124.18	1336.69
42.00	1481.51	68.6	2423.2	124.78	1343.09
42.20	1488.56	69.0	2434.8	125.37	1349.48
42.40	1495.62	69.3	2446.3	125.97	1355.88
42.60	1502.67	69.6	2457.9	126.56	1362.28
42.80	1509.73	69.9	2469.4	127.15	1368.67
43.00	1516.78	70.3	2480.9	127.75	1375.07
43.20	1523.84	70.6	2492.5	128.34	1381.46
43.40	1530.89	70.9	2504.0	128.94	1387.86
43.60	1537.95	71.2	2515.5	129.53	1394.25
43.80	1545.00	71.6	2527.1	130.12	1400.65
44.00	1552.06	71.9	2538.6	130.72	1407.05

Altitude adjustment





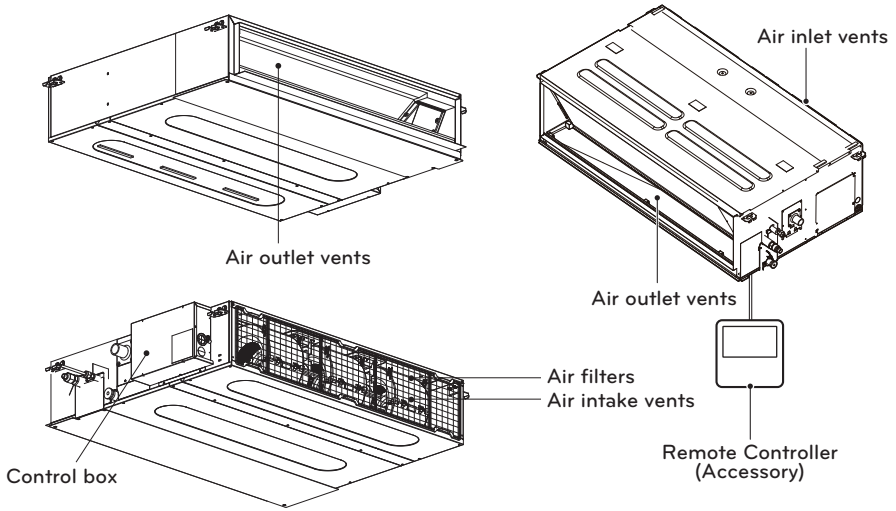

- The minimum room area of A_{\min} or TA_{\min} shall be corrected by multiplying by the altitude adjustment factor(AF) in the below table based on for building site ground level altitude (Halt) in meters(feet).

Unit : m (ft)

Halt	0	200 (656.2)	400 (1 312.3)	600 (1 968.5)	800 (2 624.7)	1 000 (3 280.8)
AF	1	1	1	1	1.02	1.05
Halt	1 200 (3 937.0)	1 400 (4 593.2)	1 600 (5 249.3)	1 800 (5 905.5)	2 000 (6 561.7)	
AF	1.07	1.1	1.12	1.15	1.18	

INSTALLATION PARTS



Name	Drain hose	Vinyl	Clamp metal	Washer for hanging bracket	Clamp (Tie Wrap)	Insulation for fitting
Quantity	1 EA	1 EA	2 EA	8 EA	4 EA	1 set
Shape						 For gas pipe  For liquid pipe

* Screws for fixing panels are attached to decoration panel.

INSTALLATION

Indoor unit

- Install the air conditioner in the location that satisfies the following conditions.
- The place shall easily bear a load exceeding four times the indoor unit's weight.
 - The place shall be able to inspect the unit as the figure.
 - The place where the unit shall be leveled.
 - The place shall easily connect with the outdoor unit.
 - The place where the unit is not affected by an electrical noise.
 - The place where air circulation in the room will be good.
 - There should not be any heat source or steam near the unit

- Confirm the positional relationship between the unit and suspension bolts.
- Installation the ceiling opening to clean the filter or service under the product.

⚠ WARNING

Make sure to be materials in a compartment handling air for circulation through a duct supplying only one room.

[Unit:mm(inch)]

Capacity (kBtu/h)	A	B
9	800 (31-1/2)	800 (31-1/2)
12/18	800 (31-1/2)	1 000 (39-3/8)
24	800 (31-1/2)	1000 (39-3/8)
30 / 36	800 (31-1/2)	1400 (55-1/8)
42/48	800 (31-1/2)	1400 (55-1/8)

Top view [Unit: mm(inch)]

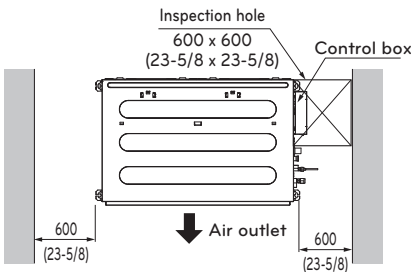

Side view [Unit: mm(inch)]

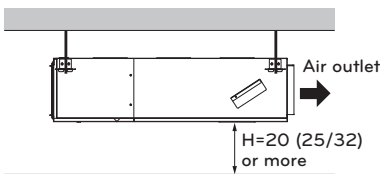

- Suitable dimension "H" is necessary to get a slope to drain as shown in the figure

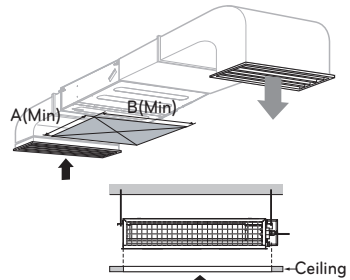

Top view

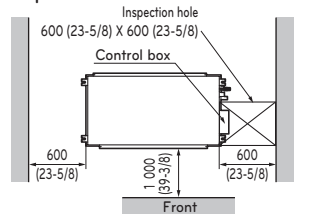

Front view

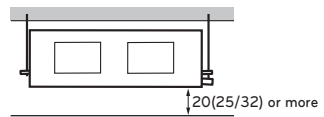

Ceiling dimension and hanging bolt location

Installation of Unit

Install the unit above the ceiling correctly.

POSITION OF SUSPENSION BOLT

- Apply a joint-canvas between the unit and duct to absorb unnecessary vibration.
- Apply a filter Accessory at air return hole.

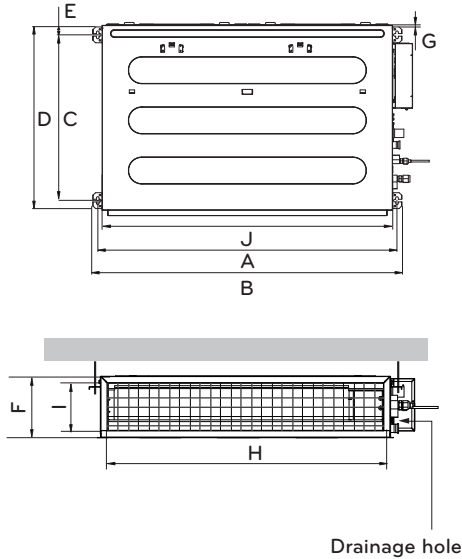

[Unit:mm(inch)]

Capacity (kBtu/h)	9 k	12 k / 18 k	24 k	30 k / 36 k	42 k / 48 k
Dimension A	733 (28-17/20)	933 (36-37/50)	933.4 (36-3/4)	1 283.4 (50-17/32)	1 283.4 (50-17/32)
B	772 (30-2/5)	972 (38-13/50)	971.6 (38-1/4)	1 321.6 (52-1/32)	1 321.6 (52-1/32)
C	628 (24-18/25)	628 (24-18/25)	619.2 (24-3/8)	619.2 (24-3/8)	619.2 (24-3/8)
D	700 (27-11/20)	700 (27-11/20)	700 (27-9/16)	700 (27-9/16)	700 (27-9/16)
E	36 (1-2/5)	36 (1-2/5)	30 (1-3/16)	30 (1-3/16)	30 (1-3/16)
F	190 (7-12/25)	190 (7-12/25)	270 (10-5/8)	270 (10-5/8)	360 (14-3/16)
G	20 (25/32)	20 (25/32)	15.2 (19/32)	15.2 (19/32)	15.2 (19/32)
H	660 (25-49/50)	860 (33-17/20)	858 (33-25/32)	1 208 (47-9/16)	1 208 (47-9/16)
I	155 (6-1/10)	155 (6-1/10)	201.4 (7-15/16)	201.4 (7-15/16)	291.4 (11-15/32)
J	700 (27-11/20)	900 (35-11/25)	900 (35-7/16)	1 250 (49-7/32)	1 250 (49-7/32)

* Install the unit leaning to a drainage hole side as a figure for easy water drainage.

POSITION OF CONSOLE BOLT

- A place where the unit will be leveled and that can support the weight of the unit.
- A place where the unit can withstand its vibration.
- A place where service can be easily performed.

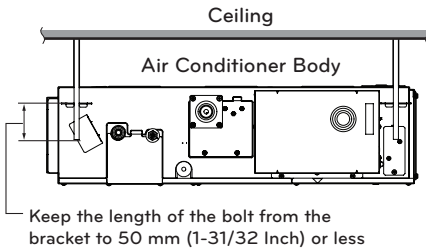
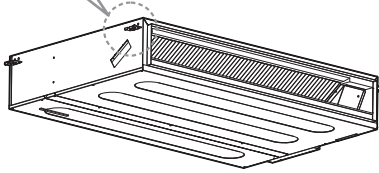
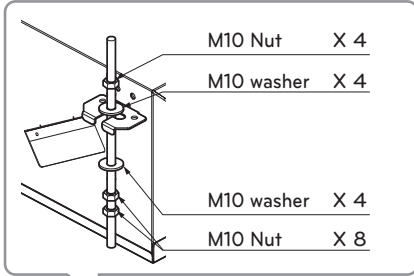

Indoor Unit Installation

- Select and mark the position for fixing bolts.
- Drill the hole for set anchor on the face of ceiling.

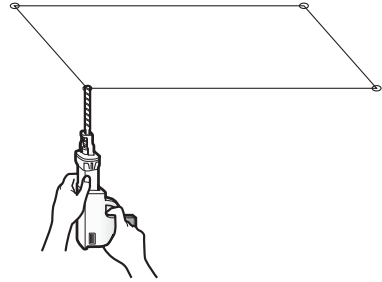

- Insert the set anchor and washer onto the suspension bolts for locking the suspension bolts on the ceiling.
- Mount the suspension bolts to the set anchor firmly.
- Secure the installation plates onto the suspension bolts (adjust level roughly) using nuts, washers and spring washers.

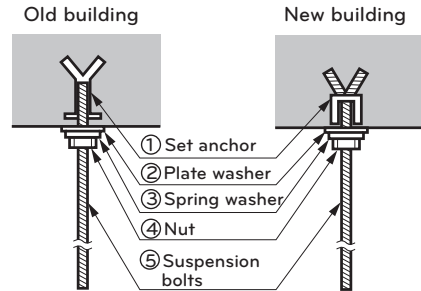

- Local supply
 - ① Set anchor
 - ② Plate washer - M10
 - ③ Spring washer - M10
 - ④ Nut - W3/8 or M10
 - ⑤ Suspension bolt - W3/8 or M10

! CAUTION

Tighten the nut and bolt to prevent unit falling.

CAUTION

- 1 Install declination of the indoor unit is very important for the drain of the duct type air conditioner.
- 2 Minimum thickness of the insulation for the connecting pipe shall be 5 mm(3/16 inch).

Front of view

- The unit must be declined to the drain hose connected when finished installation.

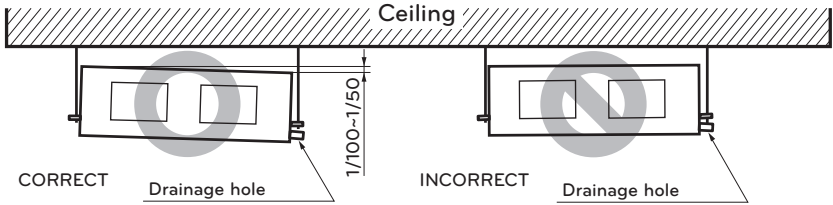

CAUTION FOR GRADIENT OF UNIT AND DRAIN PIPING

Lay the drain hose with a downward inclination so water will drain out.

- Always lay the drain with downward inclination (1/100 to 1/50). Prevent any upward flow or reverse flow in any part.
- 10 mm or thicker formed thermal insulator shall always be provided for the drain pipe.

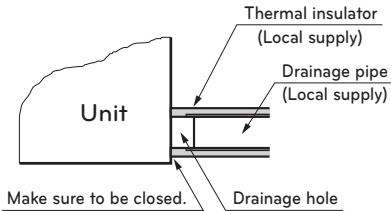

- Upward routing not allowed

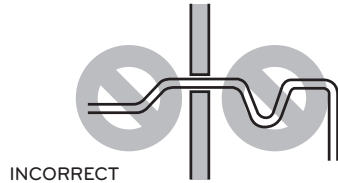

- Install the P-Trap (or U-Trap) to prevent a water leakage caused by the blocking of intake air filter.

Applied U-Trap Dimension

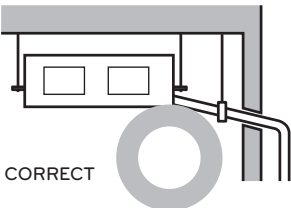

- A ≥ 70 mm(2-3/4 inch)
- B ≥ 2C
- C ≥ 2 x SP
- SP = External Pressure (mmAq(inAq))
- Ex) External Pressure = 10 mmAq (0.39 inAq)
- A ≥ 70 mm(2-3/4 inch)
- B ≥ 40 mm(1-9/16 inch)
- C ≥ 20 mm(25/32 inch)

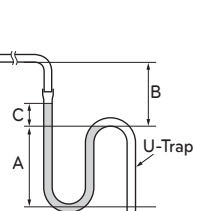

Air Filter

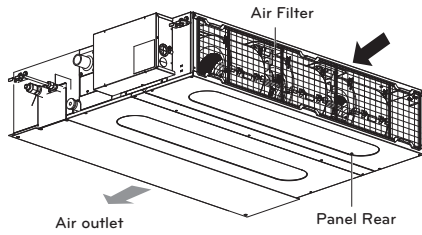

Low static duct type in case of suction from back side.

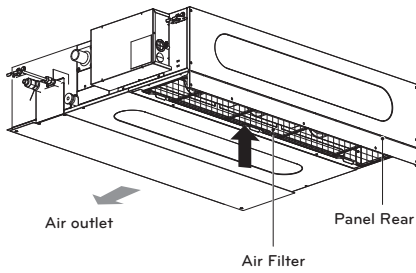

Low static duct type in case of suction from bottom side.

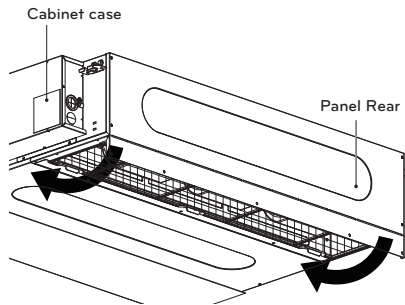

In case of suction from bottom size, bend the Panel rear and screw with cabinet case.

INSULATION, OTHERS

Insulate the joint and tubes completely.

THERMAL INSULATION

All thermal insulation must comply with local requirement.

INDOOR UNIT

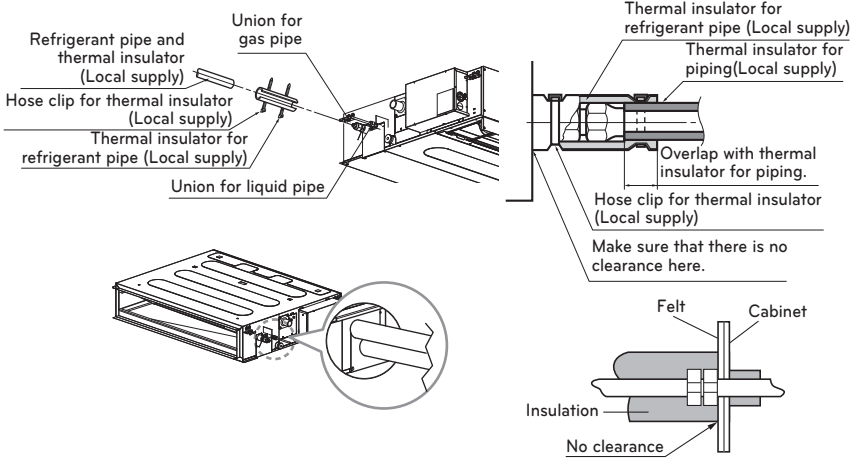

TEST AND CHECK

After all workings are finished, check the working and operation.

- Air distribution Is the air circulation good?
- Drain Is the drainage smoothly and no sweating?
- Gas leakage Is the piping connection correctly?
- Wiring Is the wiring connection correctly?
- Lock-bolt Is the lock-bolt of compressor loosened?
- Insulation Is the unit fully insulated?
- Ground Is the unit safely grounded?

Checking the Drainage

1 Remove the Air Filter.

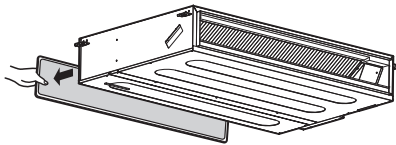

2 Check the drainage.

- Spray one or two glasses of water upon the evaporator.
- Ensure that water flows drain hose of indoor unit without any leakage.

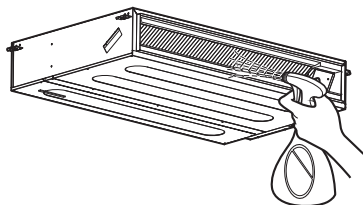

CAUTION

- Install declination of the indoor unit is very important for the drain of the duct type air conditioner.
- Minimum thickness of the insulation for the connecting pipe shall be 19 mm(3/4 inch).

Front of view

The unit must be horizontal or declined to the drain hose connected when finished installation.

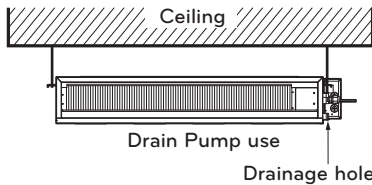

Indoor Unit Drain Piping

- Drain piping must have down-slope (1/50 to 1/100): be sure not to provide up-and-down slope to prevent reversal flow.
- During drain piping connection, be careful not to exert extra force on the drain port on the indoor unit.
- The outside diameter of the drain connection on the indoor unit is 32 mm(1-1/4 inch).

Piping material: Polyvinyl chloride pipe VP-25 and pipe fittings

- Be sure to execute heat insulation on the drain piping.

Heat insulation material: Polyethylene foam with thickness more than 8 mm(5/16 inch).

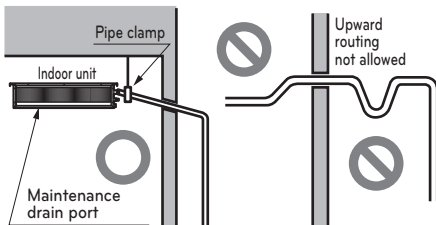

Drain test

The air conditioner uses a drain pump to drain water.

Use the following procedure to test the drain pump operation:

- Connect the main drain pipe to the exterior and leave it provisionally until the test comes to an end.
- Feed water to the flexible drain hose and check the piping for leakage.
- Be sure to check the drain pump for normal operating and noise when electrical wiring is complete.
- When the test is complete, connect the flexible drain hose to the drain port on the indoor unit.

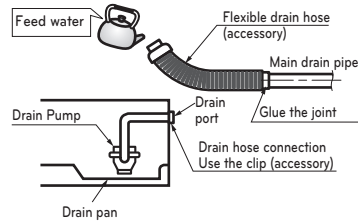

CAUTION

The supplied flexible drain hose should not be curved, neither screwed. The curved or screwed hose may cause a leakage of water.

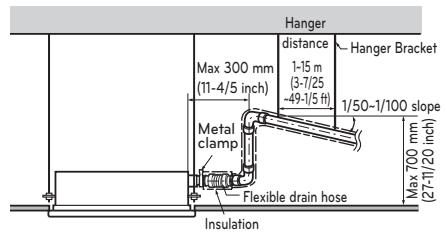

HAND OVER

Teach the customer the operation and maintenance procedures, using the operation manual.

(air filter cleaning, temperature control, etc.)

Combination indoor units

(ZMNR**G**A*)

The indoor units connectable to the outdoor unit are shown below

Indoor Unit		Outdoor Unit (kBTu/h class)	
Type	Capacity (kBTu/h class)	36	54
Vertical AHU	24	O	O
	36	X	O
Ceiling Concealed Duct (High Static)	24	O	O
	36	X	O

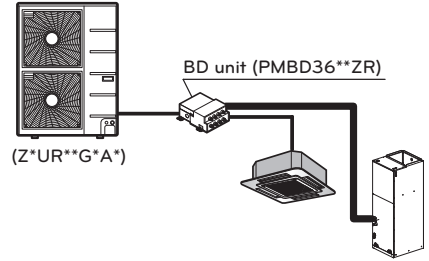

Outdoor Unit (kBTu/h class)	Total capacity of connectable indoor units (kBTu/h)
36	48
54	73

Example)
Total rated capacity index :

$$\begin{array}{r}
 4Way\ CST \\
 ZMNR18GTQA* \\
 [KNUDB18*A] \\
 \\
 VAHU \\
 KNULB361A \\
 \\
 18 \\
 + \\
 36 \times 1.3 \\
 = \\
 64.8 < 73
 \end{array}$$

NOTE

- The total capacity(in Btu/h unit) of connected indoor unit models represents the total sum of the figures expressed in the indoor model name.
- Combinations in which the total capacity of the connected indoor units exceeds the capacity of the outdoor unit will reduce the capacity of each indoor unit below the rated capacity during simultaneous operation. Therefore, if circumstances allows, combine indoor units within the capacity of the outdoor unit.
- VAHU, Ceiling Concealed Duct(High Static) type indoor unit's combination calculation method as below.
Calculation method for total capacity of connectable indoor unit to an outdoor unit = (Sum of all VAHU & Ceiling Concealed Duct(High Static) type indoor units capacity x 1.3) + Sum of all other indoor unit's capacity

Flaring work

Main cause of gas leakage is defect in flaring work. Carry out correct flaring work in the following procedure.

1 Cut the pipes

- Use the accessory piping kit or the pipes purchased locally.
- Measure the distance between the indoor and the outdoor unit.
- Cut the pipes a little longer than measured distance.
- Cut the cable 1.5 m(4.9 ft) longer than the pipe length.

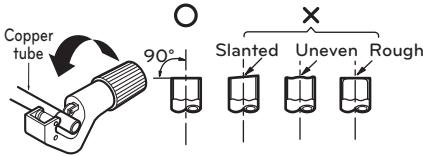

2 Burrs removal

- Completely remove all burrs from the cut cross section of pipe/tube.
- Put the end of the copper tube/pipe to downward direction as you remove burrs in order to avoid to let burrs drop in the tubing.

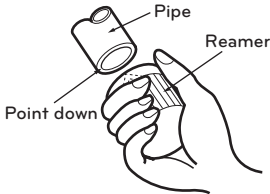

3 Putting nut on

- Remove flare nuts attached to indoor and outdoor units, than put them on pipe/tube having completed burr removal. (Not possible to put them on after flaring work)

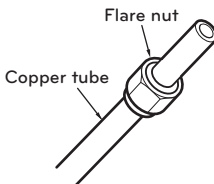

4 Flaring work

- Carry out flaring work using flaring tool as shown below.

Pipe diameter Inch (mm)	A Inch (mm)		Thickness Inch (mm)
	Wing nut type	Clutch type	
Ø 1/4 (Ø 6.35)	0.04~0.05 (1.1~1.3)	0~0.02 (0~0.5)	0.03 (0.7)
Ø 3/8 (Ø 9.52)	0.06~0.07 (1.5~1.7)		0.03 (0.8)
Ø 1/2 (Ø 12.7)	0.06~0.07 (1.6~1.8)		0.03 (0.8)
Ø 5/8 (Ø 15.88)	0.06~0.07 (1.6~1.8)		0.04 (1.0)
Ø 3/4 (Ø 19.05)	0.07~0.08 (1.9~2.1)		0.04 (1.0)

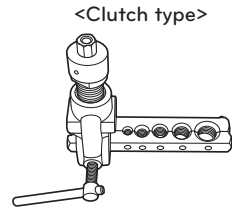
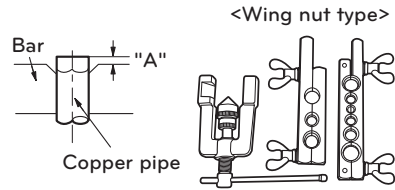

Firmly hold copper tube in a bar(or die) as indicated dimension in the table above.

5 Check

- Compare the flared work with figure.
- If flare is noted to be defective, cut off the flared section and do flaring work again.

Smooth all round

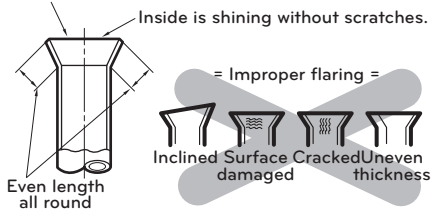

Connection of piping - Indoor, Outdoor, BD Unit

Align the center of the piping and sufficiently tighten the flare nut by hand.

Capacity (kBTu/h)	Refrigerant Connections Pipe size	
	Liquid	Gas
24	1/4 (Ø 6.35)	1/2 (Ø 12.7)
36 / 42 / 48	3/8 (Ø 9.52)	5/8 (Ø 15.88)

ODU	Model	Refrigerant Connections Pipe size	
		Liquid	Gas
Single Zone	ZMNR18GL2A*	3/8 (Ø 9.52)	5/8 (Ø 15.88)

* ZMNR18GL2A* includes the sockets.
 Ø 6.35 → Ø 9.52 x 1 EA, Ø 12.7 →
 Ø 15.88 x 1 EA, Ø 9.52 → Ø 12.7 x 1 EA

BD Unit	Refrigerant Connections Pipe Size (inch (mm))		Connectable Indoor Unit Capacity (kBTu/h class)
	Liquid	Gas	
PMBD3620	1/4 (Ø 6.35) x 2 EA	3/8 (Ø 9.52) x 2 EA	9/12/18/24 k
PMBD3630	1/4 (Ø 6.35) x 3 EA	3/8 (Ø 9.52) x 3 EA	9/12/18/24 k
PMBD3640	1/4 (Ø 6.35) x 4 EA	3/8 (Ø 9.52) x 4 EA	9/12/18/24 k
PMBD3641	1/4 (Ø 6.35) x 4 EA	3/8 (Ø 9.52) x 3 EA	9/12/18/24 k (A/B/C ROOM)
		1/2 (Ø 12.7) x 1 EA	36 k (D ROOM)

* BD Unit(PMBD3641) includes the sockets.
 (Ø 12.7 → Ø 15.88 x 1 EA,
 Ø 6.35 → Ø 9.52 x 1 EA)

Finally, tighten the flare nut with torque wrench until the wrench clicks.

- When tightening the flare nut with torque wrench ensure the direction of tightening follows the arrow on the wrench.

Piping Size		Torque		
mm	inch	kgf·cm	N·m	lbf·ft
Ø 6.35	Ø 1/4	180 ~ 250	17.6 ~ 24.5	13 ~ 18
Ø 9.52	Ø 3/8	340 ~ 420	33.3 ~ 41.2	25 ~ 30
Ø 15.88	Ø 5/8	630 ~ 820	61.7 ~ 80.4	45 ~ 59
Ø 12.7	Ø 1/2	550 ~ 660	53.9 ~ 64.7	40 ~ 48
Ø 19.05	Ø 3/4	990 ~ 1210	97.0 ~ 118.7	71 ~ 87

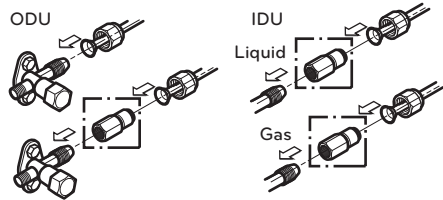
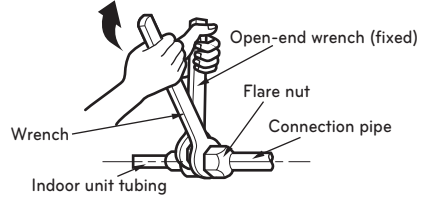
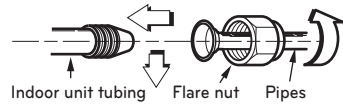

(Only Indoor Units
24 kBTu/h class)

(Only Indoor Units
ZMNR18GL2A*)

(PMBD3620** / PMBD3630** / PMBD3640**)

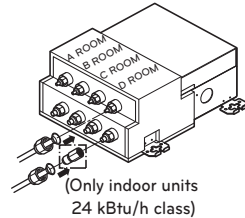

(Only indoor units
24 kBTu/h class)

(PMBD3641**)

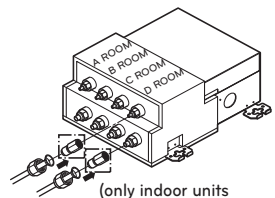



(only indoor units
36 kBTu/h class- connect "D ROOM")

Plumbing materials and storage methods

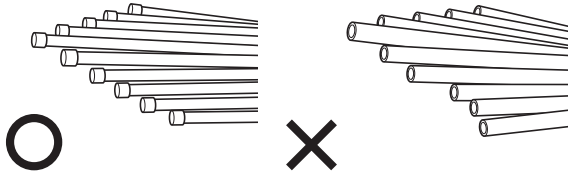
Pipe must be able to obtain the specified thickness and should be used with low impurities. Also when handling storage, pipe must be careful to prevent a fracture, deformity and wound. Should not be mixed with contaminations such as dust, moisture.

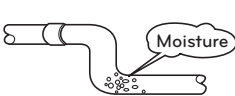

Refrigerant piping on three principles

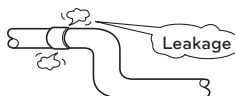
	Drying	Cleanliness	Airtight
	Should be no moisture inside	No dust inside.	There is no refrigerant leakage
Items			
Cause failure	<ul style="list-style-type: none"> - Significant hydrolysis of refrigerant oil - Degradation of refrigerant oil - Poor insulation of the compressor - Do not cold and warm - Clogging of EEV, Capillary 	<ul style="list-style-type: none"> - Degradation of refrigerant oil - Poor insulation of the compressor - Do not cold and warm - Clogging of EEV, Capillary 	<ul style="list-style-type: none"> - Gas shortages - Degradation of refrigerant oil - Poor insulation of the compressor - Do not cold and warm
Countermeasure	<ul style="list-style-type: none"> - No moisture in the pipe - Until the connection is completed, the plumbing pipe entrance should be strictly controlled. - Stop plumbing at rainy day. - Pipe entrance should be taken side or bottom. - When removal burr after cutting pipe, pipe entrance should be taken down. - Pipe entrance should be fitted cap when pass through the walls. 	<ul style="list-style-type: none"> - No dust in the pipe. - Until the connection is completed, the plumbing pipe entrance should be strictly controlled. - Pipe entrance should be taken side or bottom. - When removal burr after cutting pipe, pipe entrance should be taken down. - Pipe entrance should be fitted cap when pass through the walls. 	<ul style="list-style-type: none"> - Airtightness test should be. - Brazing operations to comply with standards. - Flare to comply with standards. - Flange connections to comply with standards.

Nitrogen substitution method

Welding, as when heating without nitrogen substitution a large amount of the oxide film is formed on the internal piping.

The oxide film is caused by clogging EEV, Capillary, oil hole of accumulator and suction hole of oil pump in compressor.

It prevents normal operation of the compressor.

In order to avoid this problem, Welding should be done after replacing air by nitrogen gas.

When welding plumbing pipe, the work is required.

How to work

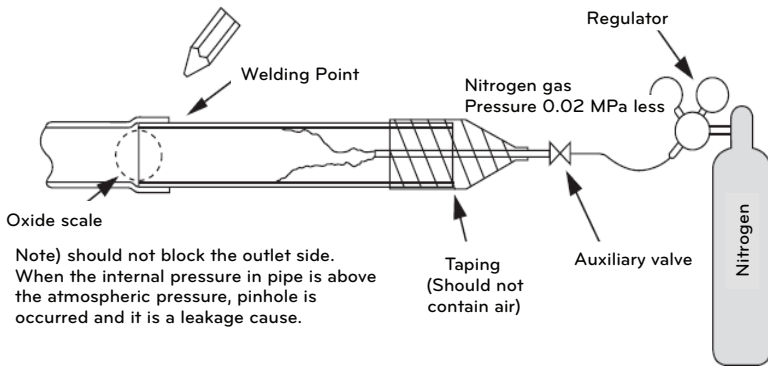

CAUTION

- Always use the nitrogen.(not use oxygen, carbon dioxide, and a Chevron gas):
Please use the following nitrogen pressure 0.02MPa
Oxygen ----- Promotes oxidative degradation of refrigerant oil.
Because it is flammable, it is strictly prohibited to use
Carbon dioxide --- Degrade the drying characteristics of gas
Chevron Gas ----- Toxic gas occurs when exposed to direct flame.
- Always use a pressure reducing valve.
- Please do not use commercially available antioxidant.
The residual material seems to be the oxide scale is observed.
In fact, due to the organic acids generated by oxidation of the alcohol contained in the anti-oxidants, ants nest corrosion occurs. (causes of organic acid → alcohol + copper + water + temperature)

Heat insulation

- 1 Use the heat insulation material for the refrigerant piping which has an excellent heat-resistance (over 120 °C).
- 2 Precautions in high humidity circumstance: This air conditioner has been tested according to the "KS Standard Conditions with Mist" and confirmed that there is not any default. However, if it is operated for a long time in high humid atmosphere (dew point temperature: more than 23 °C), water drops are liable to fall. In this case, add heat insulation material according to the following procedure:
 - Heat insulation material to be prepared...
Adiabatic glass wool with thickness 10 to 20 mm.
 - Stick glass wool on all air conditioners that are located in ceiling atmosphere.

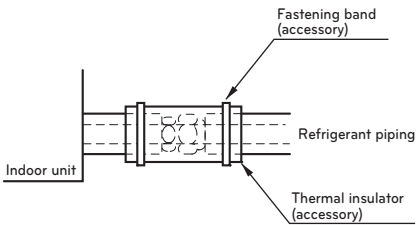

Wiring Connection

- Remove the control box cover for electrical connection between the indoor and outdoor unit. (Remove screws ①.)
- Open the control box cover and connect the Remote controller cord and Indoor power wires.
- Use the cord clumper to fix the cord.

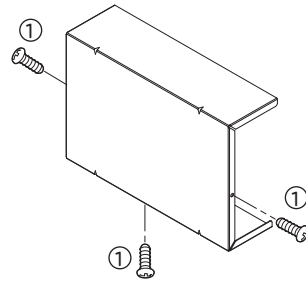
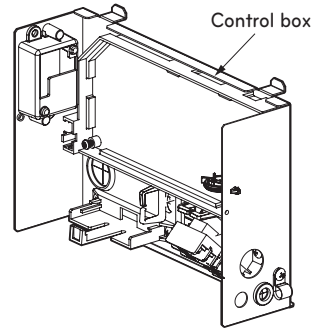

Connection method of the connecting cable(Example)

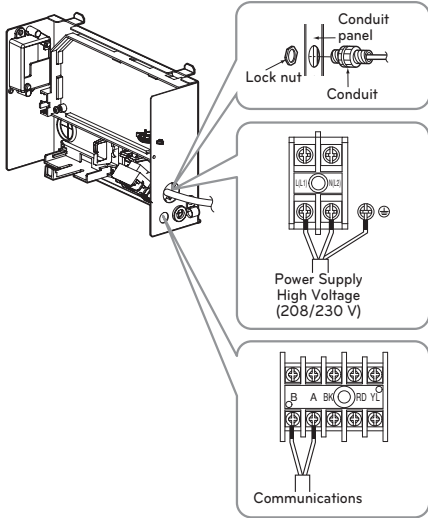

⚠ WARNING

Loose wiring may cause the terminal to overheat or result in unit malfunction. A fire hazard may also exist. Therefore, be sure all wiring is tightly connected.

<M2,M3 Duct>

- Open the control box cover and connect the remote controller cables, transmission cables and indoor power cables.
- Control box cover is consist of one panel.

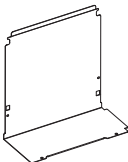

Control box cover can be separated from main body

Separate whole cover(when access from bottom of the product). Remove screws on the bottom panel and grab the both panel with two hands and pull down the whole cover.

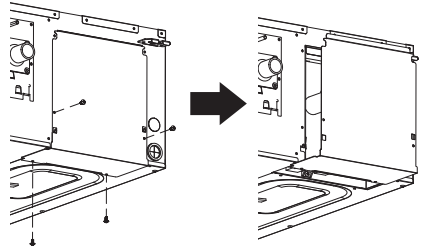

After remove the control box cover, insert cables onto the bush and conduit and then connect at terminal block.

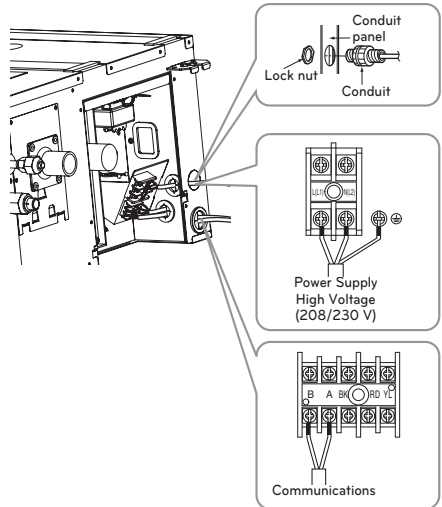

Insulation, others

Insulate the joint and tubes completely.

THERMAL INSULATION

All thermal insulation must comply with local requirement.

INDOOR UNIT

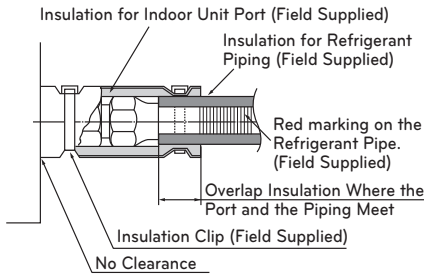
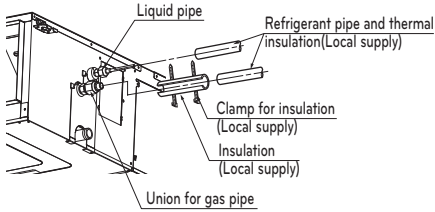

Checking the safe handling

Mark refrigerant pipes with red Pantone® Matching System (PMS) #185 or RAL 3020 after flare fittings or brazing. This marking must extend a minimum of 1 inch (25mm) in both directions and shall be replaced if removed.

Return all labels, especially red marking, to their original condition to ensure the next consumer or servicer is aware of the presence of a flammable refrigerant.

Ensure that the red marking for flammable refrigerant identification in the process tube area is visible following servicing.

CAUTION

The power and communication connecting cable between the outdoor and indoor units must comply with the following specifications: NRTL Recognized (for example, UL or ETL recognized and CSA certified).

AWG 18 is the minimum recommended wire size, however, the selected conductors must comply with local codes and be suitable for installation in wet locations.

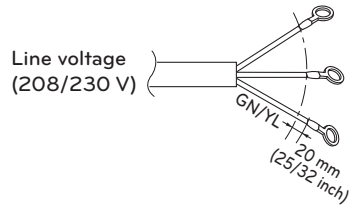

Power supply cable

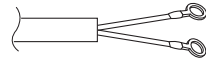

Communication cable

If the supply cord is damaged, it must be replaced by a special cord or assembly available from the manufacturer of its service agent. When the connection line between the indoor unit and outdoor unit and outdoor unit is over 40 m, connect the telecommunication line and power line separately.

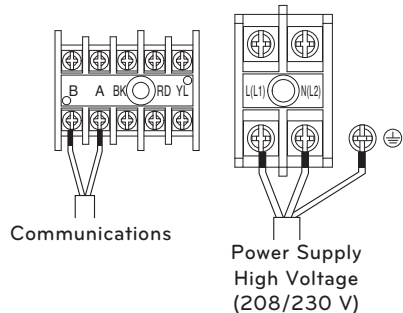

Communications

Power Supply High Voltage (208/230 V)

Precautions when laying power and ground wiring

Use round pressure terminals for connections to the power terminal block. When laying ground wiring, you must use round pressure terminals.



When none are available, follow the instructions below.

- Do not connect wiring of different thicknesses to the power terminal block. (Slack in the power wiring may cause abnormal heat.)
- When connecting wiring which is the same thickness, do as shown in the figure below.

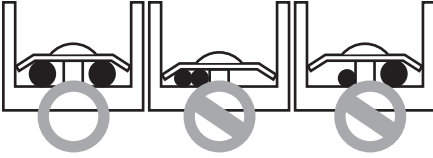

- For wiring, use the designated power wire and connect firmly, then secure to prevent outside pressure being exerted on the terminal block.
- Use an appropriate screwdriver for tightening the terminal screws. A screwdriver with a small head will strip the head and make proper tightening impossible.
- Over-tightening the terminal screws may break them.

NOTE

Use connection cable NRTL(UL, ETL, CAS...) listed and stranded copper(4) THHN conductors, sunlight (UV) resistant ROHS compliant PVC jacket 600 V direct burial listed, approved for wet conditions. Temperature rated for $-20\text{ }^{\circ}\text{C}(-4\text{ }^{\circ}\text{F})$ to $90\text{ }^{\circ}\text{C}(194\text{ }^{\circ}\text{F})$. And this cable should be enclosed in conduit.

! WARNING

- Be sure to comply with local and national codes while running the wire from the indoor unit to the outdoor unit(size of wire and wiring method, etc).
- Every wire must be connected firmly.
- No wire should be allowed to touch refrigerant tubing, the compressor or any moving parts.
- The communication wirings of air conditioner should be separate and isolated from external device's electric wiring such as computers, elevator, radio & Television broadcasting facilities, as well as medical imaging offices.

REMOTE CONTROLLER INSTALLATION

※ Remote controller is provided as an accessory.

Please fix tightly using provided screw after placing remote controller setup board on the place where you like to setup.

- Please set it up not to bend because poor setup could take place if setup board bends.
- Please set up remote controller board fit to the reclamation box if there is a reclamation box.

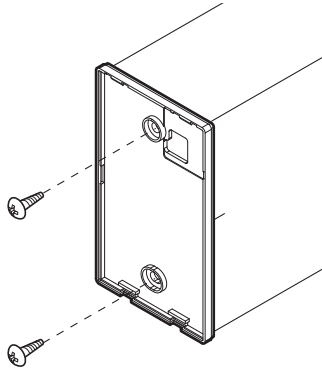

Can set up Wired remote controller cable into three directions.

- Setup direction: the surface of wall reclamation, upper, right
- If setting up remote controller cable into upper and right side, please set up after removing remote controller cable guide groove.
- * Remove guide groove with long nose.

- ① Reclamation to the surface of the wall
- ② Upper part guide groove
- ③ Right part guide groove

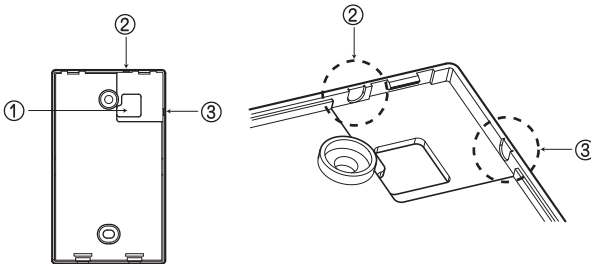

<Wire guide grooves>

Please connect indoor unit and remote controller using connection cable.

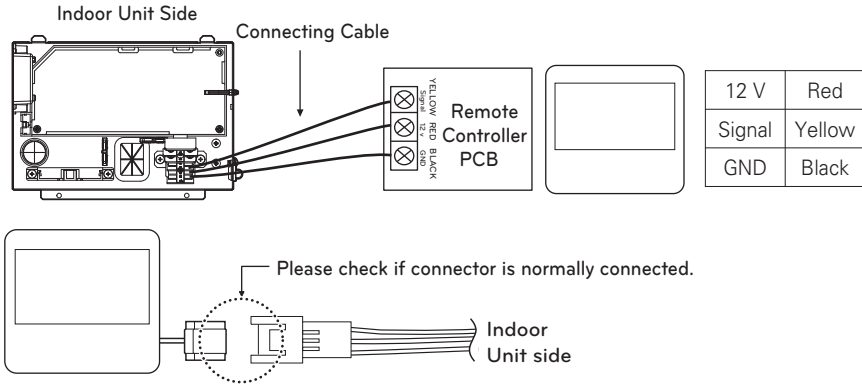

Please use extension cable if the distance between wired remote controller and indoor unit is more than 10 m (32-4/5 ft).

Please fix remote controller upper part into the setup board attached to the surface of the wall, as the picture below, and then, connect with setup board by pressing lower part.

- Please connect not to make a gap at the remote controller and setup board's upper and lower, right and left part.

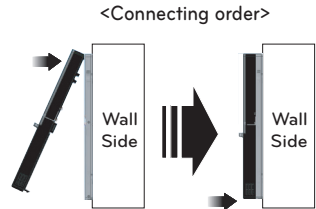

When separating remote controller from setup board, as the picture below, after inserting into the lower separating hole using screw driver and then, spinning clockwise, remote controller is separated.

- There are two separating holes. Please individually separate one at a time.
- Please be careful not to damage the inside components when separating.

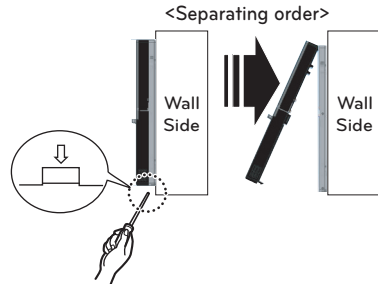

CAUTION

When installing the wired remote controller, do not bury it in the wall. (It can cause damage in the temperature sensor.)

Do not install the cable to be 50 m or above. (It can cause communication error.)

- When installing the extension cable, check the connecting direction of the connector of the remote controller side and the product side for correct installation.
- If you install the extension cable in the opposite direction, the connector will not be connected.
- Specification of extension cable: 2547 1007 22# 2 core 3 shield 5 or above.
- Apply totally enclosed noncombustible conduit in case of local building code Requiring plenum cable usage.

Wired remote controller installation

Since the room temperature sensor is in the remote controller, the remote controller box should be installed in a place away from direct sunlight, high humidity and direct supply of cold air to maintain proper space temperature. Install the remote controller about 5 ft(1.5 m) above the floor in an area with good air circulation at an average temperature.

Do not install the remote controller where it can be affected by:

- Drafts, or dead spots behind doors and in corners.
- Hot or cold air from ducts.
- Radiant heat from sun or appliances.
- Concealed pipes and chimneys.
- Uncontrolled areas such as an outside wall behind the remote controller.
- This remote controller is equipped with LCD. display. For proper display of the remote controller LCD's, the remote controller should be installed properly as shown in Fig.1.
(The standard height is 4~5 ft (1.2~1.5 m) from floor level.)

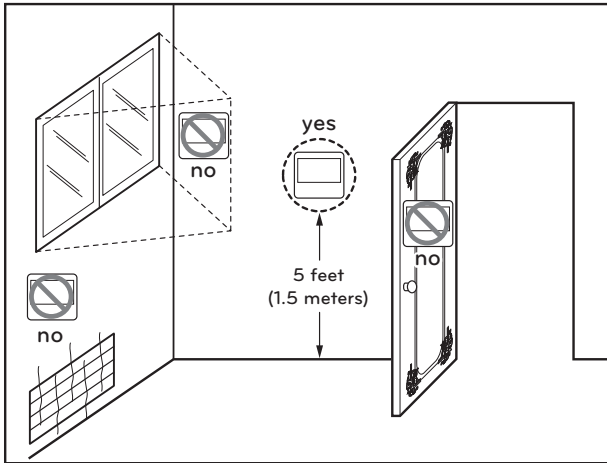

[Fig.1]

HOW TO SET E.S.P?

Installer Setting - E.S.P.

This is the function that decides the strength of the wind for each wind level and because this function is to make the installation easier.

- If you set ESP incorrectly, the air conditioner may malfunction.
- This setting must be carried out by a certificated-technician.

※ **The procedure of setting E.S.P. is refer to the manual of remote controller.**

- Precaution shall be taken not to alter the E.S.P value corresponded to each air flow section.
- E.S.P value can be varied according to the products.
- In the case of going to the next air flow rate stage by pressing the fan-speed button during the setup of the E.S.P value, the E.S.P value of previous air flow rate will be maintained by remembering the E.S.P value prior to the shift.

(Unit : CMM)

Capacity	Step	CFM	Static Pressure (mmAq (in.Aq))					
			0 (0)	1 (0.04)	2 (0.08)	3 (0.12)	4 (0.16)	5 (0.2)
			Setting Value					
9 k	HIGH	318	98	103	108	116	125	130
	MID	247	82	88	94	102	110	118
	LOW	194	69	76	83	91	99	109
12 k	HIGH	353	95	99	104	109	116	125
	MID	300	86	91	96	101	108	116
	LOW	247	78	82	87	93	100	108
18 k	HIGH	530	123	125	129	134	140	145
	MID	441	109	112	117	123	129	136
	LOW	353	95	99	104	109	116	124

Capacity	Step	CFM	Static Pressure (mmAq (in.Aq))										
			4 (0.16)	5 (0.2)	6 (0.24)	7 (0.28)	8 (0.31)	9 (0.35)	10 (0.39)	11 (0.43)	12 (0.47)	13 (0.51)	15 (0.59)
			Setting Value										
30 k	HIGH	989	92	96	99	101	105	108	115	118	124	124	124
	MID	848	88	92	94	95	100	101	108	113	118	118	118
	LOW	741	84	88	89	90	95	96	100	105	110	112	113
36 k	HIGH	1 130	109	112	115	119	122	126	128	131	134	137	144
	MID	989	101	105	108	112	115	119	123	127	130	133	138
	LOW	848	92	97	101	105	109	113	117	121	124	127	134
42 k	HIGH	1 413	83	89	92	94	98	100	102	105	108	110	116
	MID	1 200	78	82	84	89	94	96	98	101	104	106	112
	LOW	989	74	76	79	82	89	92	94	96	99	102	107
48 k	HIGH	1 766	94	97	100	104	107	109	112	115	117	119	121
	MID	1 589	90	92	96	98	102	104	106	109	112	114	117
	LOW	1 413	82	89	92	94	98	100	102	105	108	110	113

Installer Setting - Auto ESP

This function automatically sets the rotation speed of the fans corresponding to each step of rated airflow for easy installation.

Please refer to the manual for separately sold remote control for detailed setup.

NOTE

If this function is incorrectly set especially, in case of mismatching the voltage, the air conditioner may malfunction.

this function must be set by the installation specialist that holds an installation license. (please check the product type)

This function is only available on some products.

NOTE

- If the heat exchanger is not dry, please set the device to operate in air circulation mode for 15 minutes.
- The air filter must be properly attached to the suction side of the product.
- Adjust the dampers so that each air inlet and outlet exhaust the required air.
- Please do not use the set auto air flow function when using various booster fans (outdoor air treatment device or ERV through ducts).
- Please reinitiate the set auto air flow function if the duct shape has changed since its initial installation.
- When setting the voltage manually, the set air flow will differ from the actual air flow if the set voltage is different from the actual voltage.
- When setting voltage manually, measure the actual voltage and select the set voltage on the remote control.
- Failure to follow the above method may cause the actual air flow to differ from the rated air flow.

SELF-DIAGNOSIS FUNCTION

Indoor Unit Error

Ex) Error 03 (Remote controller error)

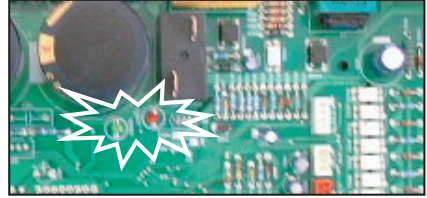
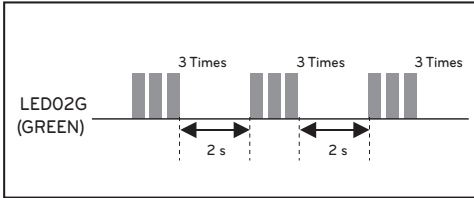

Error Code	Description	LED 1(Red)	LED 2(Green)	Indoor status
01	Indoor Room sensor error	0	1 time ●	OFF
02	Indoor in-pipe sensor error	0	2 times ●	OFF
03	Remote controller error	0	3 times ●	OFF
04	Drain pump error	0	4 times ●	OFF
05	Communication error indoor and outdoor	0	5 times ●	OFF
06	Indoor out-pipe sensor error	0	6 times ●	OFF
09	EEPROM error (indoor)	0	9 times ●	OFF
10	BLDC motor fan lock (indoor)	1 time ●	0	OFF

* Because remote controller turn off when occur ERROR in simultaneous operation system, it should check LED blinks of outdoor in order to confirm error code.

* Repeatedly after LED1 is turned on and off as the Error code number of tens digit, LED2 is turned on and off as the Error code number of single-digit.

DIP SWITCH SETTING

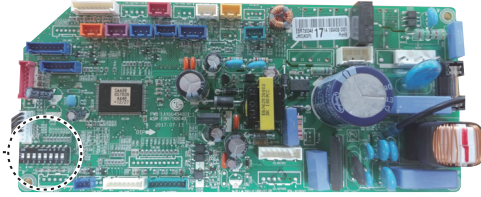
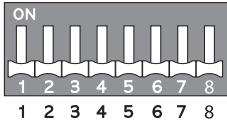

Indoor PCB

Function		Description	Setting Off	Setting On	Default
SW3	Group Control	Selection of Master or Slave	Master	Slave	Off
SW4	Dry Contact Mode	Selection of Dry Contact Mode	Wired/Wireless remote controller Selection of Manual or Auto operation Mode	Auto	Off
SW5	Installation	Fan continuous operation	Continuous operation Removal	Working	Off

R32 refrigerant leakage sensor

- The refrigerant leak detector detects the concentration of refrigerant (R32) in the air.
- When the concentration of refrigerant in the air is 5 000 ppm or higher, the wired remote controller displays an error and R32 sensor Sub PCB issues an alarm so that the user realizes that there is a refrigerant leak. (The alarm function is only available in some products.)

Step1 : Install the R32 refrigerant leakage sensor to indoor unit, if required. (for more information, See the accessory manual)

Step2 : Check whether the power is connected.

Step3 : After connecting the power, 7 seconds is the initial sensor startup time.

Step4 : Input Refrigerant leak detection sensor setting with remote controller.

Wireless remote controller

- 1 When JET COOL button pressed, press RESET button.



- 2 By using the TEMPERATURE SETTING button, set function code and setting value.

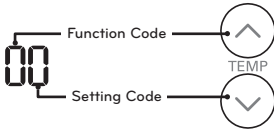

- 3 Designate the function code and the setting code and then press the On/Off button toward the indoor unit 1 time.
* Code value for Refrigerant Leak Detector installation. (28 : Not installed, 29 : Installed)



Remote Control Display Window

- 4 Reset the remote controller to use the general operation mode.



Standard 3 wired remote controller

- 1 In the menu screen, press [<, >] (left/right) button to select the setting category, and press [^] (up) button for 3 seconds to enter the password input screen for the installer setting.
- 2 Input the password and press [OK] button to move to the installer setting list.

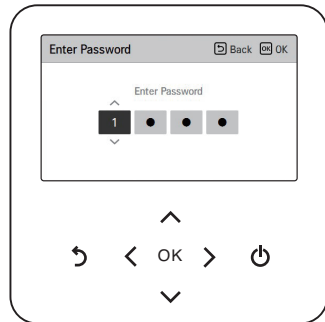
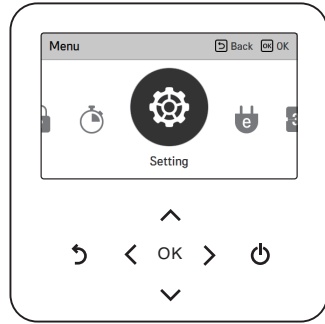

※ Installer setting password

Main screen → menu → setting → service
→ RMC version information → SW Version

Example) SW version : 1.00.1 a

In the above case, the password is 1001.

- In the installer setting list, select the Refrigerant Leak Sensor and set the value to "Install" using [<,>(left/right)] button.

Installer	
Humidification Kit	Not Installed
Ventilation Kit	Installed
Aux Heater	Step 1
Refrigerant Leak Sensor	Not Installed

Function	Value
Refrigerant Leak Sensor	Not install / Install

Deluxe Wired Remote Controller

- Tap the menu and select the Installer setting.
- Please enter the password. The configurable items are displayed.
 - How to know the password
Move to the "SW version" menu. (Menu → Service contents → SW version)
If SW version is 1.000, password is 1000.

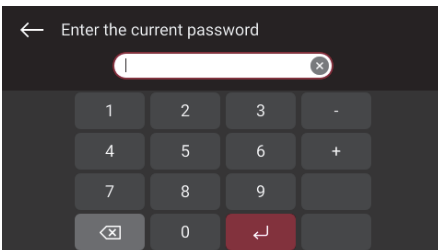
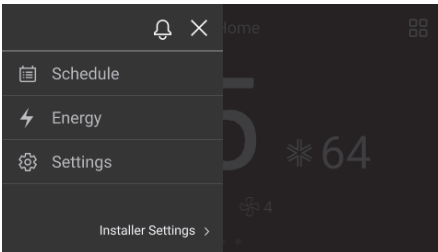

- Tap the Magnifier icon in the upper right corner, making it easy to find what you want.
 - Auto-complete items are displayed based on the characters you enter.
 - You can also search by the code number of installer setting.

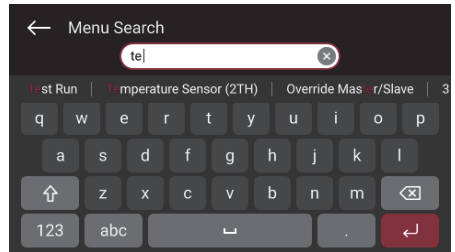
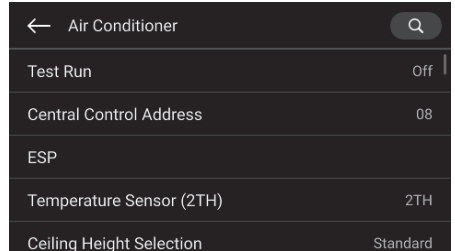

- In the installer setting list, select the Refrigerant Leakage detection sensor and set the value to "Installed".

Function	Description	Option
Refrigerant leakage detection sensor	Please set whether to install the option kit.	Not installed / Installed

Troubleshooting

If a R32 refrigerant leakage detecting system is activated, the following actions will be operated automatically.

- Error code will be displayed.
- The fan of the indoor unit where the error code is displayed will turn on.
- The unit cannot be used until the error code disappears.

WARNING

- If there are error code such as 228,229 and 230, ventilate the room and contact authorized personnel immediately.
- The R32 refrigerant leakage sensor must be replaced after detecting any gases or at the end of its lifetime (3650 days).
- REFRIGERANT SENSORS for REFRIGERANT DETECTION SYSTEMS shall only be replaced with sensors specified by the appliance manufacture.
- R32 refrigerant leakage detecting system replacement shall be carried out by authorized personnel only.
- There is possibility detecting other gases, not R32. Do not use highly concentrated chemicals (e.g. Ethanol, Smoke, Hair spray and pesticide) near the indoor unit. R32 refrigerant leakage sensor may detect incorrectly.

Error Code	Error Type	Error point	Main reasons
CH 228	Refrigerant leak detector malfunction error	Refrigerant leak detector has failed.	<ul style="list-style-type: none"> • The sensor is breaking of short. • Abnormal voltage of DC converter. • Abnormal operation of microprocessor.

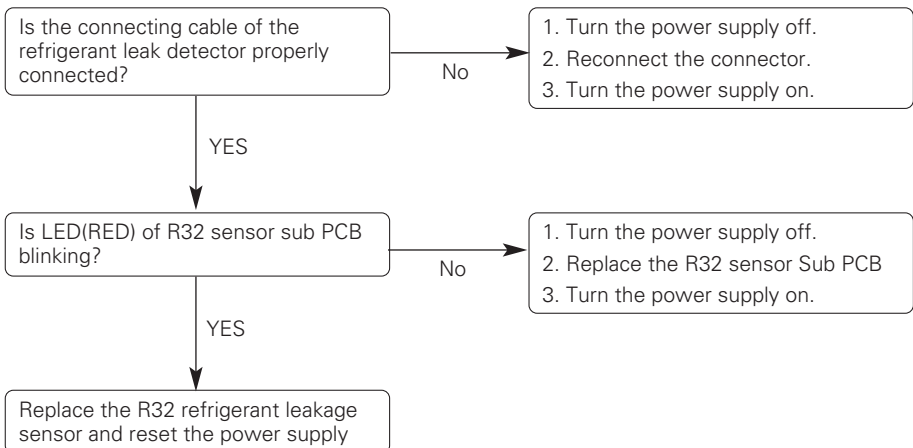

Error Code	Error Type	Error point	Main reasons
CH 229	Refrigerant leak detector lifetime error	The lifetime of the refrigerant leak detector has reached the end	<ul style="list-style-type: none"> The lifetime of the refrigerant leak detector has been reached, so replace the sensor.

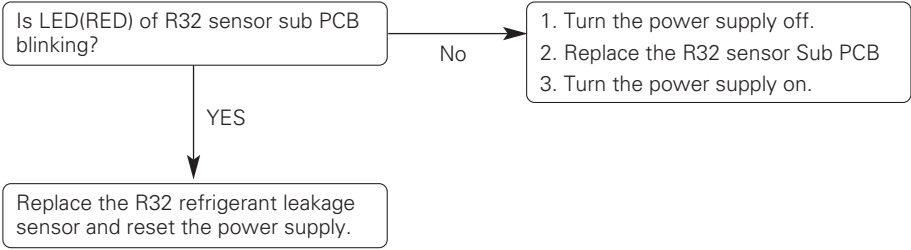

Error Code	Error Type	Error point	Main reasons
CH 230	Refrigerant leak detection error	Refrigerant leak detected by refrigerant leak detector.	<ul style="list-style-type: none"> Refrigerant leak detection

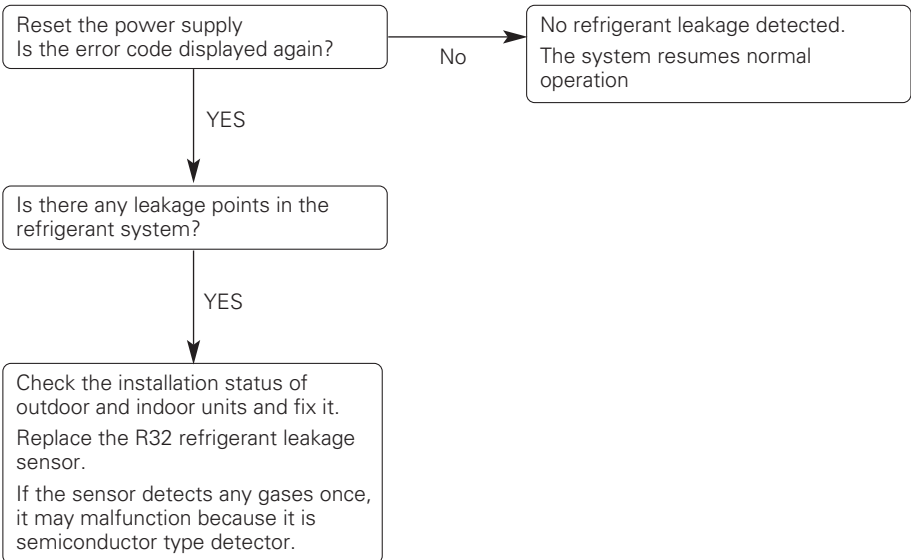



US	Please call the installing contractor of your product, as warranty service will be provided by them.
CANADA	Service call Number # : (888) LG Canada, (888) 542-2623 Numéro pour les appels de service : LG Canada, 1-888-542-2623