

Series GM™

Gas Boilers



Installation, Operation & Maintenance Manual



PeerlessBoilers.com

TABLE OF CONTENTS

USING THIS MANUAL	1	7. CSD CODE REQUIREMENTS	20
A. INSTALLATION SEQUENCE	1	A. GENERAL	20
B. SPECIAL ATTENTION BOXES	1	B. CSD PART CF REQUIREMENTS	20
1. PREINSTALLATION	2	C. CSD PART CW REQUIREMENTS	20
A. ACCESSIBILITY CLEARANCES	2	D. CSD MODULAR AND MULTIPLE BOILER REQUIREMENTS	20
B. CLEARANCE FROM COMBUSTIBLE CONSTRUCTION	2	E. CSD PART CE ELECTRICAL REQUIREMENTS	21
C. COMBUSTION AND VENTILATION AIR ...	2	8. START-UP PROCEDURES	22
D. INSTALLATION SURVEY	5	A. COMPLETING THE INSTALLATION	22
E. CIRCULATORS	5	B. CONTROL DESCRIPTIONS	25
F. PLANNING THE LAYOUT	5	C. ADJUSTMENT OF GAS PRESSURE REGULATOR	25
2. BOILER SET-UP	6	D. CHECKING BURNER INPUT	25
3. WATER PIPING AND CONTROLS	7	E. CHECK-OUT PROCEDURE	26
A. BOILER SUPPLY AND RETURN	7	9. TROUBLESHOOTING	27
B. SAFETY RELIEF VALVE	8	A. SHUT-DOWN CAUSED BY PILOT OUTAGE, VENT SAFETY SHUTOFF SWITCH OR FLAME ROLLOUT SAFETY SHUTOFF SWITCH	27
C. PIPING FOR ZONED SYSTEMS	9	B. TROUBLESHOOTING GUIDES	27
D. EXPANSION TANK	10	10. MAINTENANCE	30
E. INDIRECT-FIRED WATER HEATER	10	A. GENERAL	31
F. FREEZE PROTECTION	10	B. DAILY (WITH BOILER IN USE)	31
4. VENTING	11	C. WEEKLY (WITH BOILER IN USE)	31
A. DRAFT HOOD	11	D. MONTHLY (WITH BOILER IN USE)	31
B. AUTOMATIC VENT DAMPER INSTALLATION – GENERAL	12	E. ANNUALLY (BEFORE START OF HEATING SEASON)	32
C. VENT PIPING AND CHIMNEY	12	11. BOILER DIMENSIONS & RATINGS	33
D. BOILER REMOVAL FROM COMMON VENTING SYSTEM	13	12. REPAIR PARTS	34
5. GAS PIPING	15		
6. ELECTRICAL	17		
A. WIRING	17		
B. SEQUENCE OF OPERATION, INTERMITTENT IGNITION	19		

USING THIS MANUAL

A. INSTALLATION SEQUENCE

Follow the installation instructions provided in this manual in the order shown. The order of these instructions have been set in order to provide the installer with a logical sequence of steps that will minimize potential interferences and maximize safety during boiler installation.

B. SPECIAL ATTENTION BOXES

Throughout this manual you will see special attention boxes intended to supplement the instructions and make special notice of potential hazards. These categories mean, in the judgment of PB Heat, LLC:



DANGER

Indicates a condition or hazard which will cause severe personal injury, death or major property damage.



WARNING

Indicates a condition or hazard which may cause severe personal injury, death or major property damage.



CAUTION

Indicates a condition or hazard which will or can cause minor personal injury or property damage.



NOTICE

Indicates special attention is needed, but not directly related to potential personal injury or property damage.

1. PREINSTALLATION

⚠ NOTICE

The equipment must be installed in accordance with installation requirements of the authority having jurisdiction or, in the absence of such requirements, to the current edition of the *National Fuel Gas Code*, ANSI Z223.1/NFPA 54 or CAN/CGA B149 Installation Codes.

Where required by the authority having jurisdiction, the installation must conform to *American Society of Mechanical Engineers Safety Code for Controls and Safety Devices for Automatically Fired Boilers*, ASME CSD-1.

Carefully read these instructions before beginning work. Understand all aspects of the installation. Contact your PB Heat sales representative or customer service for help in answering questions.

This boiler must be installed by a qualified contractor. The boiler warranty can be voided if the boiler is not installed, maintained and serviced correctly.

A. ACCESSIBILITY CLEARANCES

Install boiler with not less than 24" (610 mm) between the top and front of the boiler and adjacent wall or other appliance, when access is required for servicing.

B. CLEARANCE FROM COMBUSTIBLE CONSTRUCTION

The design of this boiler is certified for alcove installation with the following clearances from combustible construction:

1. Sides: 6" (152 mm)
2. Top of Jacket: 36" (914 mm)
3. Draft Hood: 6" (152 mm)
4. Vent Pipe: 6" (152 mm) [1" (25 mm) for Type B vent]
5. Rear of Jacket: 6" (152 mm)
6. Hot Water Pipes: 1" (25 mm)

⚠ WARNING

Do not install this boiler on combustible flooring. Boiler installation on combustible flooring is a fire hazard.

7. If it is necessary to build a non-combustible floor pad over top of an existing combustible floor, construct pad as stated in the current edition of *National Fuel Gas Code Handbook* under "Installation of Specific Equipment", or CAN/CGA B149 Installation Codes under "General".

⚠ WARNING

Do not install boiler on carpeting. Boiler installation on carpeting is a fire hazard.

C. COMBUSTION AND VENTILATION AIR

1. Provide adequate facilities for combustion and ventilation air in accordance with current edition of *National Fuel Gas Code* under "Air for Combustion and Ventilation", or applicable provisions of the local building code, or CAN/CGA B149 Installation Codes. Subsections 2 through 8 below are based on *National Fuel Gas Code* requirements.
2. Required Combustion Air Volume: The total required volume of indoor air is to be the sum of the required volumes for all appliances located within the space. Rooms communicating directly with the space in which the appliances are installed and through combustion air openings sized as indicated in Subsection 3 are considered part of the required volume. The required volume of indoor air is to be determined by one of two methods.
 - a. **Standard Method**: The minimum required volume of indoor air (room volume) shall be 50 cubic feet per 1000 BTU/Hr (4.8 m³/kW). This method is to be used if the air infiltration rate is unknown or if the rate of air infiltration is known to be greater than 0.6 air changes per hour. As an option, this method may be used if the air infiltration rate is known to be between 0.6 and 0.4 air changes per hour. If the air infiltration rate is known to be below 0.4 then the *Known Air Infiltration Rate Method* must be used. If the building in which this appliance is to be installed is unusually tight, PB Heat recommends that the air infiltration rate be determined.
 - b. **Known Air Infiltration Rate Method**: Where the air infiltration rate of a structure is known, the minimum required volume of indoor air for appliances other than fan assisted and for the Series GM™ Boiler shall be determined as follows:

$$\text{Required Volume}_{\text{other}} = \frac{21 \text{ ft}^3}{\text{ACH}} \left(\frac{I_{\text{other}}}{1000 \text{ Btu/hr}} \right)$$

where:

I_{other} = Input of appliances other than fan assisted in Btu/hr

ACH = air change per hour (percent of the volume of the space exchanged per hour, expressed as a decimal)

For fan assisted appliances, calculate the required volume of air using the following equation:

$$\text{Required Volume}_{fan} = \frac{15 \text{ ft}^3}{\text{ACH}} \left(\frac{I_{fan}}{1000 \text{ Btu/hr}} \right)$$

I_{fan} = Input of the fan assisted appliances in Btu/hr

Note: These calculations are not to be used for infiltration rates greater than 0.60 ACH.

3. **Indoor Air Opening Size and Location:** Openings connecting indoor spaces shall be sized and located as follows:

- a. **Combining spaces on the same floor:**

Provide two permanent openings communicating with additional spaces that have a minimum free area of 1 in² per 1000 Btu/hr (22 cm² per 1000 W) of the total input rating of all gas fired equipment but not less than 100 in² (645 cm²). One opening is to begin within 12 inches (305 mm) of the top of the space and the other is to begin within 12 inches (305 mm) of the floor. The minimum dimension of either of these openings shall be 3 inches (76 mm). See Figure 1.1 for an illustration of this arrangement.

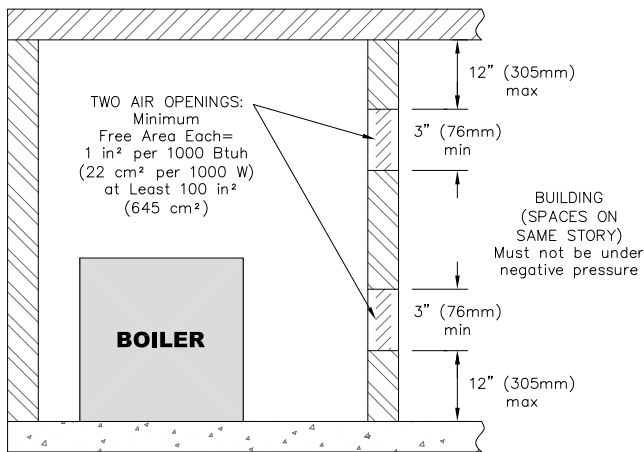

Figure 1.1: Air Openings - All Air from Indoors on the Same Floor

- b. **Combining spaces on different floors:**

Provide one or more permanent openings that have a total minimum free area of 2 in² per 1000 Btu/hr (44 cm² per 1000 W) of total input rating of all equipment. See Figure 1.2 for an illustration of this arrangement.

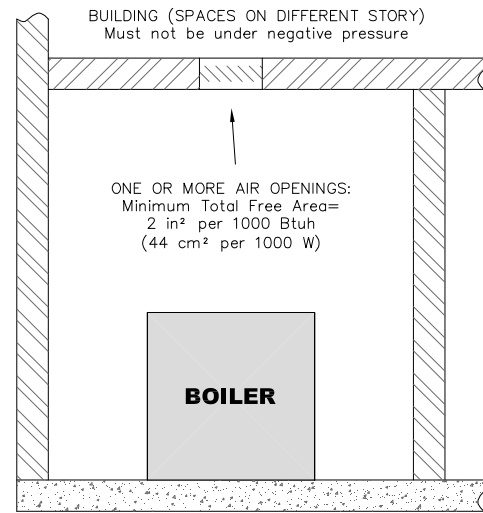

Figure 1.2: Air Openings - All Air from Indoors on Different Floors

4. **Outdoor Combustion Air:** Outdoor combustion air is to be provided through one or two permanent openings. The minimum dimension of these air openings is 3 inches (76 mm).

- a. **Two Permanent Opening Method:** Provide two permanent openings. One opening is to begin within 12 inches (305 mm) of the top of the space and the other is to begin within 12 inches (305 mm) of the floor. The openings are to communicate directly or by ducts with the outdoors or with spaces that freely communicate with the outdoors. The size of the openings shall be determined as follows:

- i. Where communicating directly or through vertical ducts with the outdoors each opening shall have a minimum free area of 1 in² per 4000 Btu/hr (22 cm² per 4000 W) of total input rating for all equipment in the space. See Figure 1.3 for openings directly communicating with the outdoors or Figure 1.4 for openings connected by ducts to the outdoors.

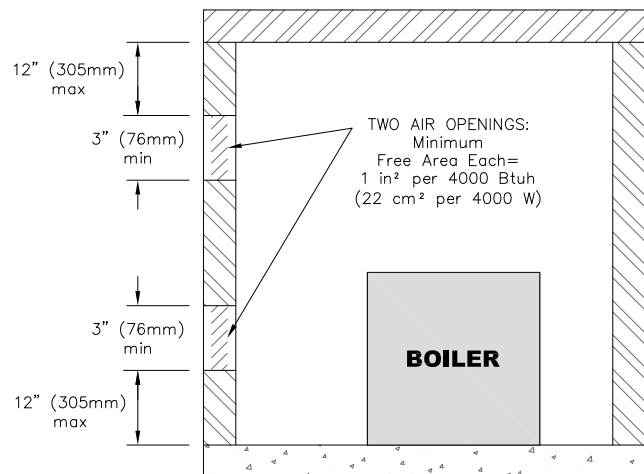

Figure 1.3: Air Openings - All Air Directly from Outdoors

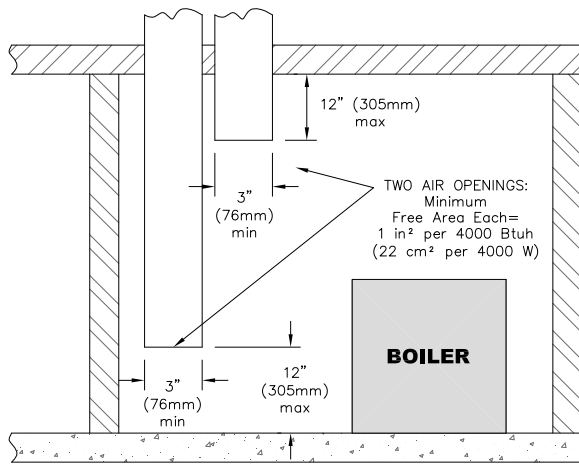

Figure 1.4: Air Openings – All Air from Outdoors through Vertical Ducts

- ii. Where communicating with the outdoors through horizontal ducts, each opening shall have a minimum free area of 1 in² per 2000 Btu/hr (22 cm² per 2000 W) of total rated input for all appliances in the space. See Figure 1.5.

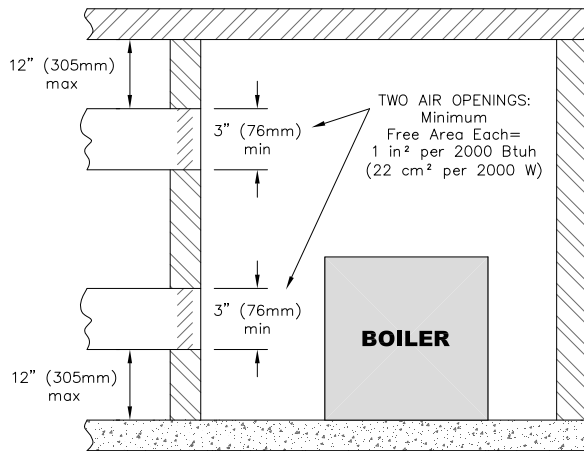

Figure 1.5: Air Openings – All Air from Outdoors through Horizontal Ducts

- b. **One Permanent Opening Method:** Provide one permanent opening beginning within 12 inches (305 mm) of the top of the space. The opening shall communicate directly with the outdoors, communicate through a vertical or horizontal duct, or communicate with a space that freely communicates with the outdoors. The opening shall have a minimum free area of 1 in² per 3000 Btu/hr of total rated input for all appliances in the space and not less than the sum of the cross-sectional areas of all vent connectors in the space. The gas-fired equipment shall have clearances of at least 1 inch (25 mm) from the sides and back and 6 inches (150 mm) from the front of the appliance. See Figure 1.6 for this arrangement.

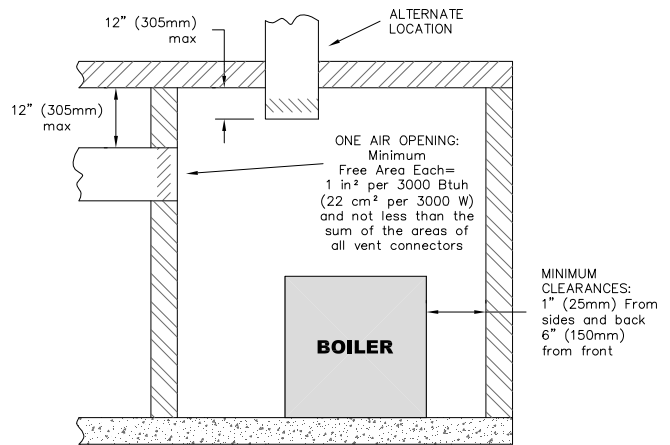

Figure 1.6: Air Openings – All Air from Outdoors through One Opening

- 5. **Combination Indoor and Outdoor Combustion Air:** If the required volume of indoor air exceeds the available indoor air volume, outdoor air openings or ducts may be used to supplement the available indoor air provided:
 - a. The size and location of the indoor openings comply with Subsection 3.
 - b. The outdoor openings are to be located in accordance with Subsection 4.
 - c. The size of the outdoor openings are to be sized as follows:

$$A_{req} = A_{full} \times \left(1 - \frac{V_{avail}}{V_{req}} \right)$$

where:

- A_{req} = minimum area of outdoor openings.
- A_{full} = full size of outdoor openings calculated in accordance with Subsection 4.
- V_{avail} = available indoor air volume
- V_{req} = required indoor air volume

- 6. **Engineered Installations:** Engineered combustion air installations shall provide an adequate supply of combustion, ventilation, and dilution air and shall be approved by the authority having jurisdiction.
- 7. **Mechanical Combustion Air Supply:**
 - a. In installations where all combustion air is provided by a mechanical air supply system, the combustion air shall be supplied from the outdoors at the minimum rate of 0.35 ft³/min per 1000 Btu/hr (0.034 m³/min per 1000 W) of the total rated input of all appliances in the space.
 - b. In installations where exhaust fans are installed, additional air shall be provided to replace the exhaust air.

- c. Each of the appliances served shall be interlocked to the mechanical air supply to prevent main burner operation when the mechanical air supply system is not in operation.
- d. In buildings where the combustion air is provided by the mechanical ventilation system, the system shall provide the specified combustion air rate in addition to the required ventilation air.

8. Louvers & Grills:

- a. The required size of openings for combustion, ventilation, and dilution air shall be based on the net free area of each opening.
 - i. Where the free area through a louver or grille is known, it shall be used in calculating the opening size required to provide the free area specified.
 - ii. Where the free area through a louver or grille is not known, it shall be assumed that wooden louvers will have 25% free area and metal louvers and grilles will have 75% free area.
 - iii. Nonmotorized dampers shall be fixed in the open position.
- b. Motorized dampers shall be interlocked with the equipment so that they are proven in the full open position prior to ignition and during operation of the main burner.
 - i. The interlock shall prevent the main burner from igniting if the damper fails to open during burner startup.
 - ii. The interlock shall shut down the burner if the damper closes during burner operation.

9. Combustion Air Ducts

- a. Ducts shall be constructed of galvanized steel or an equivalent corrosion-resistant material.
- b. Ducts shall terminate in an unobstructed space, allowing free movement of combustion air to the appliances.
- c. Ducts shall serve a single space.
- d. Ducts shall not serve both upper and lower combustion air openings where both such openings are used. The separation between ducts serving upper and lower combustion air openings shall be maintained to the source of combustion air.

- e. Ducts shall not be screened where terminating in an attic space.
- f. Horizontal upper combustion air ducts shall not slope downward toward the source of the combustion air.
- g. The remaining space surrounding a chimney liner, gas vent, special gas vent, or plastic piping installed within a masonry, metal, or factory built chimney shall not be used to supply combustion air.
- h. Combustion air intake openings located on the exterior of buildings shall have the lowest side of the combustion air intake opening at least 12 inches (305 mm) above grade.



WARNING

Liquefied Petroleum (LP) is heavier than air and may collect or “pool” in a low area in the event of a leak from defective equipment. This gas may then ignite, resulting in a fire or explosion.

D. INSTALLATION SURVEY

For new and existing installations, a Water Installation Survey is available from PB Heat. The survey will provide information on how a hot water boiler works with your specific system and will provide an overview of hot water system operation in general.

E. CIRCULATORS

The Series GM™ boiler is not equipped with a circulator or a means to control circulator operation. Provide circulator and zone controls, such as Taco zoning circulator or Honeywell R845.

F. PLANNING THE LAYOUT

Prepare sketches and notes of the layout to minimize the possibility of interferences with new or existing equipment, piping, venting and wiring.

2. BOILER SET-UP

1. Provide a sound, level foundation. Locate boiler as near to the chimney or outside wall as possible and centralized with respect to the heating system.
2. Locate boiler in front of installation position before removing crate.
3. Separate the wood shipping pallet from the boiler base by removing two (2) hold-down bolts at each end of the boiler base.
4. Move boiler into final position.

3. WATER PIPING AND CONTROLS

Design piping and size circulator(s) to suit the system. Refer to the I=B=R - Residential Hydronic Heating Installation/Design Guide and the PB Heat Water Survey for guidance.

A. BOILER SUPPLY AND RETURN

Install boiler to protect the gas ignition system components from water (dripping, spraying, etc.) during appliance operation and service (circulator replacement, condensate trap, control replacements, etc.).

1. **Remove shipping nipple** from supply tapping.
2. **Install temperature-pressure gage** with tee in supply tapping. Nipple, tee, bushing and gage are located in trim carton. See Figure 3.1.
3. **Install drain valve.** Remove jacket front panel. Install drain valve with tee in return tapping. Nipple, tee, bushing and drain valve are located in trim carton. See Figure 3.3. Tee may be installed with run in either horizontal or vertical orientation.
4. **Install supply piping,** return piping and circulator. See Figure 3.2.
 - a. If boiler is installed above radiation level, provide a low water cutoff device in the supply piping above boiler. See Figure 3.2.

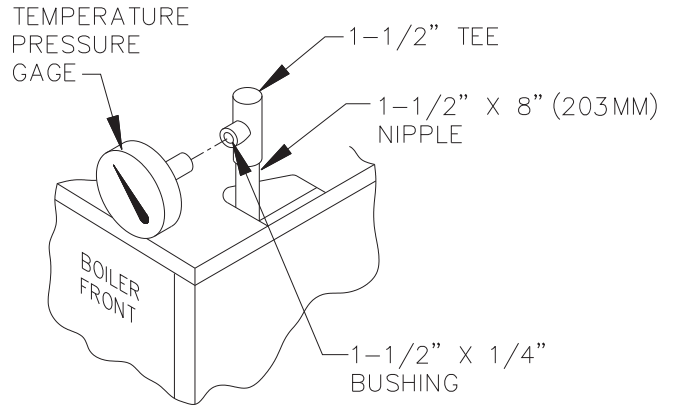

Figure 3.1: Temperature-Pressure Gage Installation

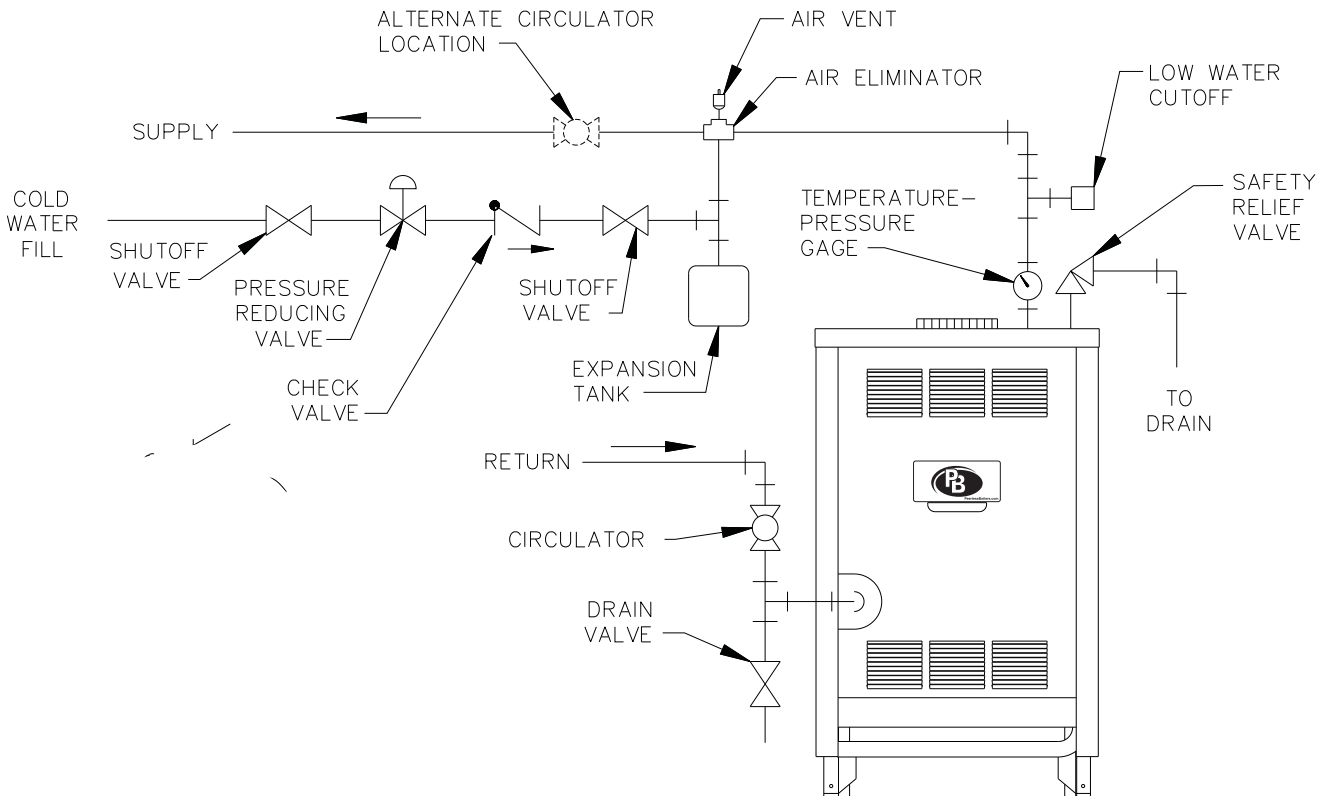

Figure 3.2: Typical Supply and Return Piping

WATER PIPING AND CONTROLS

- b. When system return water temperature will be below 130°F (54°C), pipe the boiler with a bypass arrangement to blend the system return and hot supply to obtain at least 130°F (54°C) entering the boiler. For more information on bypass piping, consult the PB Heat Water Installation Survey.
- c. If this boiler and distribution system is used in conjunction with a refrigeration system, pipe the chilled medium in parallel with the boiler and install the proper valve to prevent the chilled medium from entering the boiler. See Figure 3.4.
- d. When the boiler is connected to heating coils located in air handling units where they may be exposed to refrigerated air circulation, install flow control valves or other automatic means to prevent gravity circulation of the boiler water during the cooling cycle.

B. SAFETY RELIEF VALVE

1. Locate safety relief valve and nipple in trim carton.
2. Install safety relief valve in 3/4 NPT tapping behind supply tapping. Safety relief valve must be installed with spindle in vertical position. See Figure 3.5.

CAUTION

Pipe the discharge of safety relief valve to prevent injury in the event of pressure relief. Pipe the discharge to a drain. Provide piping that is the same size as the safety relief valve outlet.

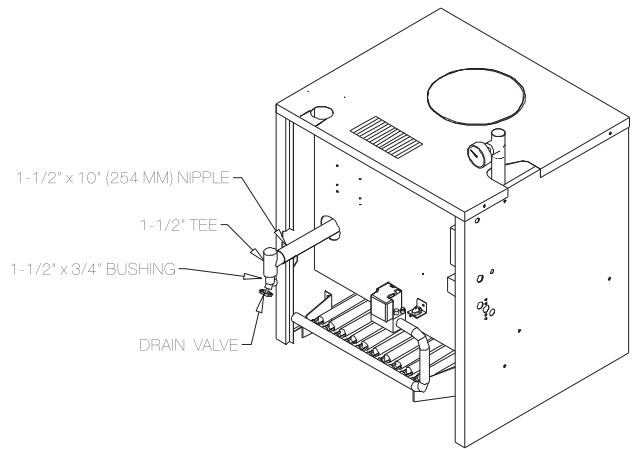

Figure 3.3: Drain Valve Installation

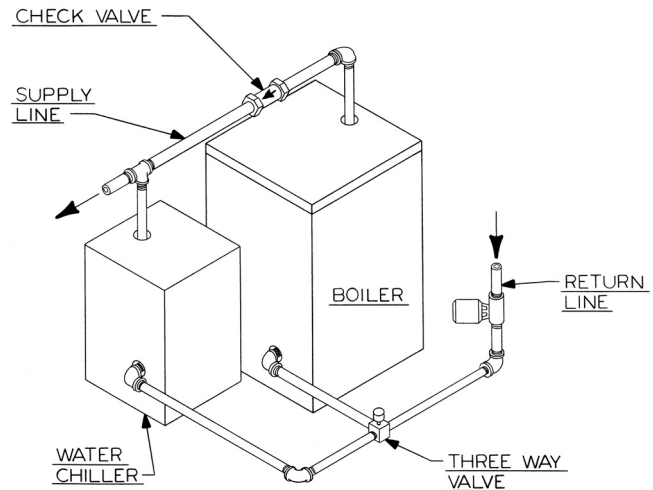

Figure 3.4: Parallel Hook-up with Water Chiller

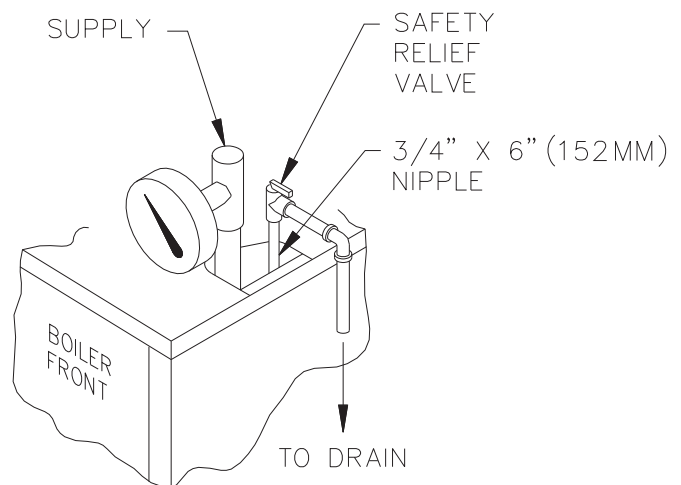

Figure 3.5: Safety Relief Valve Installation

C. PIPING FOR ZONED SYSTEMS

1. See Figures 3.6 and 3.7 for basic zoned system layouts. Circulators may be installed in either supply or return piping. Refer to PB Heat Water Installation Survey for additional information.
2. Run each zone pipe down then up to zone to prevent air accumulation in piping.
3. If required, provide means to isolate and drain each zone separately.

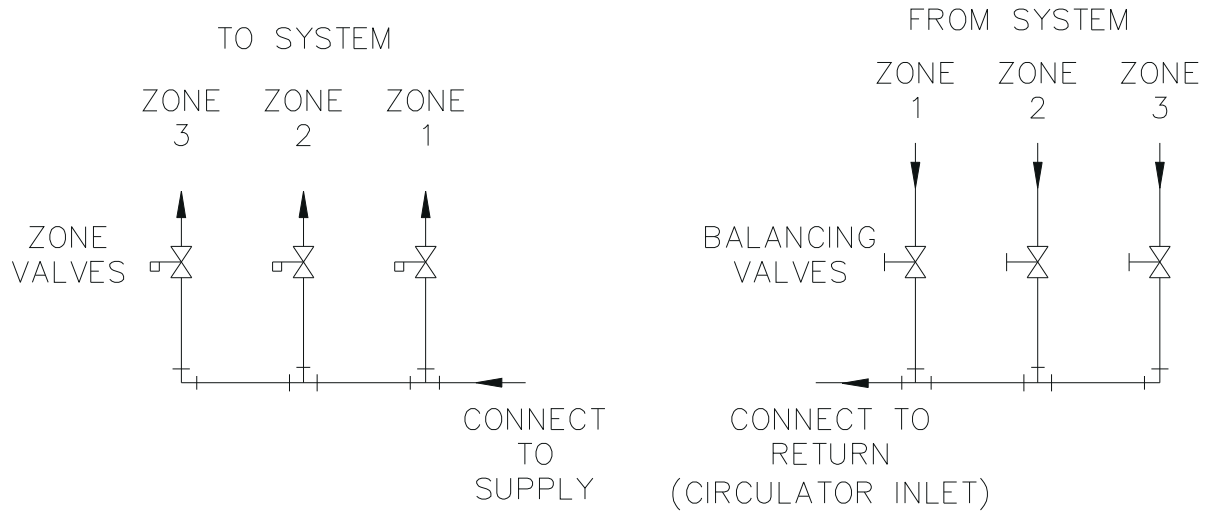

Figure 3.6: Zone Piping with Zone Valves

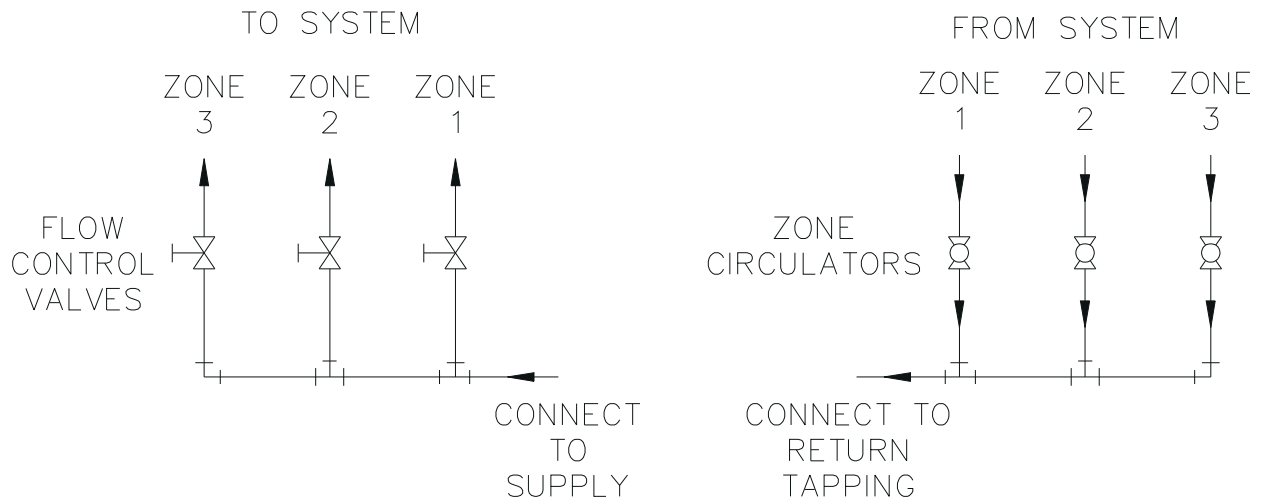

Figure 3.7: Zone Piping with Circulators

D. EXPANSION TANK

1. Consult the tank manufacturer's instructions for specific information relating to tank installation. Size the expansion tank for the required system volume and capacity. See Table 11.1 for boiler's water content.
2. Expansion tanks are available with built-in fill valves and check valves for reducing supply water pressure and maintaining minimum system pressure. Check the design features of the tank and provide valves as necessary.

Refer to Figure 3.2 for typical expansion tank piping.

E. INDIRECT-FIRED WATER HEATER

Boiler may be used as heat source for indirect-fired water heater. Refer to Figure 3.8 for typical piping. Follow the instructions provided by the water heater manufacturer. Pipe the water heater as if a separate space heating zone.

F. FREEZE PROTECTION

For new or existing systems that must be freeze-protected:

⚠ WARNING

Use only inhibited propylene glycol solutions of up to 50% by volume with water. Ethylene glycol is toxic and can attack gaskets and seals used in hydronic systems.

1. Glycol for hydronic applications is specially formulated with inhibitors which prevent the glycol from attacking metallic system components. Make certain that the system fluid is checked for the correct glycol concentration and inhibitor level.
2. Antifreeze solutions expand more than water. For example, a 50% by volume solution expands 4.8% in volume for a temperature increase from 32°F (0°C) to 180°F (82°C), while water expands 3% with the same temperature rise. Allowance must be made for this expansion in system design.
3. For more information, consult the PB Heat Water Installation Survey and the antifreeze manufacturer.

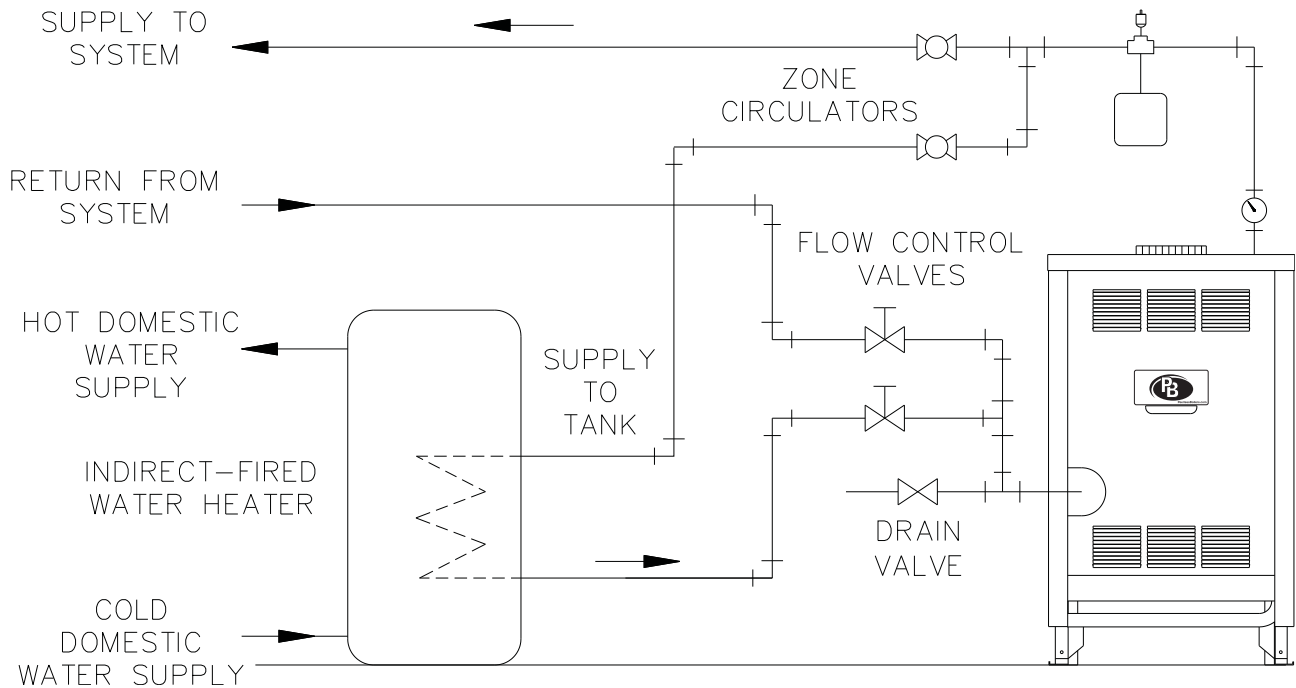

Figure 3.8: Typical Piping with Indirect-Fired Water Heater

4. VENTING

A. DRAFT HOOD

1. The boiler is equipped with a draft hood designed to:
 - a. provide for the ready escape of flue gases from the boiler in the event of no draft.
 - b. prevent a backdraft from entering the boiler.
 - c. control stack draft during operation.

The draft hood must be installed without alteration. Make certain there are no obstructions to airflow to the relief opening.

2. Position draft hood with 1" (25 mm) diameter hole in conical portion of draft hood (for vent safety shutoff switch) towards front right corner of boiler. Secure to flue collector with sheet metal screws. See Figure 4.1.
3. The boiler is equipped with a vent safety shutoff switch. The switch is shipped in a cloth bag attached to the harness on the exterior of the boiler. Attach switch to holes in the conical portion of the draft hood using the screws provided in bag. See Figure 4.1.

Vent safety shutoff switch wiring harness must extend to vent safety shutoff switch without excessive slack. To adjust harness length, squeeze strain relief bushing to release from jacket. Adjust harness to proper length. Reinsert strain relief bushing.

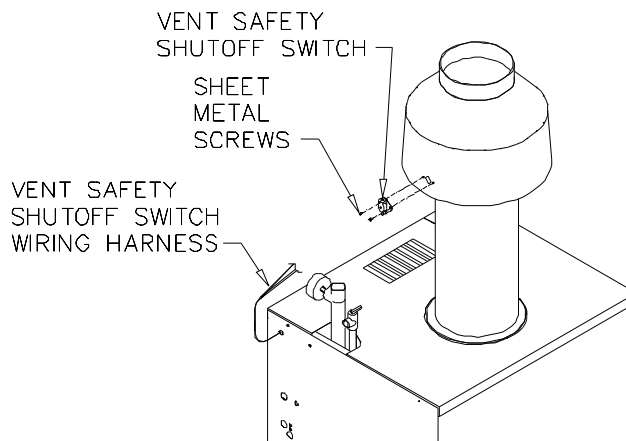

Figure 4.1: Draft Hood and Vent Safety Shutoff Switch Installation

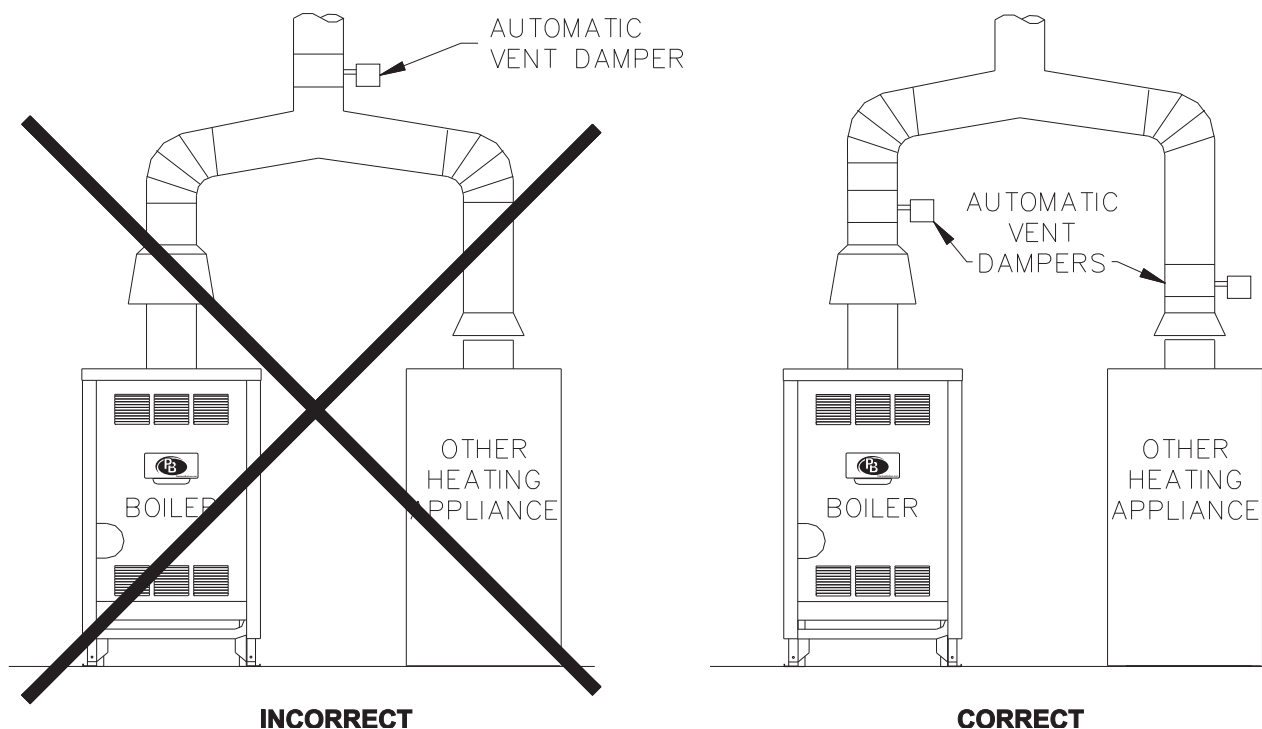

Figure 4.2: Venting Multiple Appliances

B. AUTOMATIC VENT DAMPER INSTALLATION – GENERAL

1. Do not use one vent damper to control two or more heating appliances. See Figure 4.2.
2. Follow these and the installation instructions included with the vent damper. Observe the cautions and warnings that accompany all instructions.
3. Provide minimum 6 inch (152 mm) clearance between automatic vent damper and combustible construction. Increase clearance if required by vent damper manufacturer's instructions. Provide adequate space for vent damper access and service.
4. The automatic vent damper can be mounted directly onto the draft hood outlet or in vent piping close to the boiler.

See Figure 4.3 for installation with vent damper mounted in vertical position. See Figure 4.4 for installation with vent damper mounted in horizontal position. Mount the unit to avoid excessive heat on the operator or condensation drips into the operator.

- a. Orient the vent damper operator to facilitate connection of the vent damper harness to knockout on right side of boiler. See Figure 6.1.
 - b. Orient vent damper direction arrow in direction of vent gas flow. Direction arrow must be visible from front of boiler.
5. Damper must be in open position when main burners are operating.

Le registre doit être en position ouverte lorsque le brûleur principal de l'appareil fonctionne.

C. VENT PIPING AND CHIMNEY

1. Install vent piping in accordance with current edition of *National Fuel Gas Code*, ANSI Z223.1/NFPA 54 under "Venting of Equipment", or applicable provisions of the local building codes, or CAN/CGA B149 Installation Codes.
2. Inspect the existing chimney and lining for structural soundness, corrosion and perforations. Repair as necessary.
3. Install vent pipe to slope upward at least 1/4" per lineal foot (21 mm per meter) between the draft hood outlet and the chimney.
4. Before connection of joints, inspect the vent pipe interior for foreign objects such as tools, equipment, rags, etc. and remove if present.
5. Insert vent pipe into but not beyond the inside wall of the chimney flue.
6. Do not connect vent connectors serving appliances vented by natural draft into any portion of mechanical draft systems operating under positive pressure.
7. Support horizontal portions of the venting system to prevent sagging by use of metal strapping or equivalent means. Locate supports at no more than four (4) foot (122 cm) intervals, or in accordance with vent system manufacturer's installation instructions.

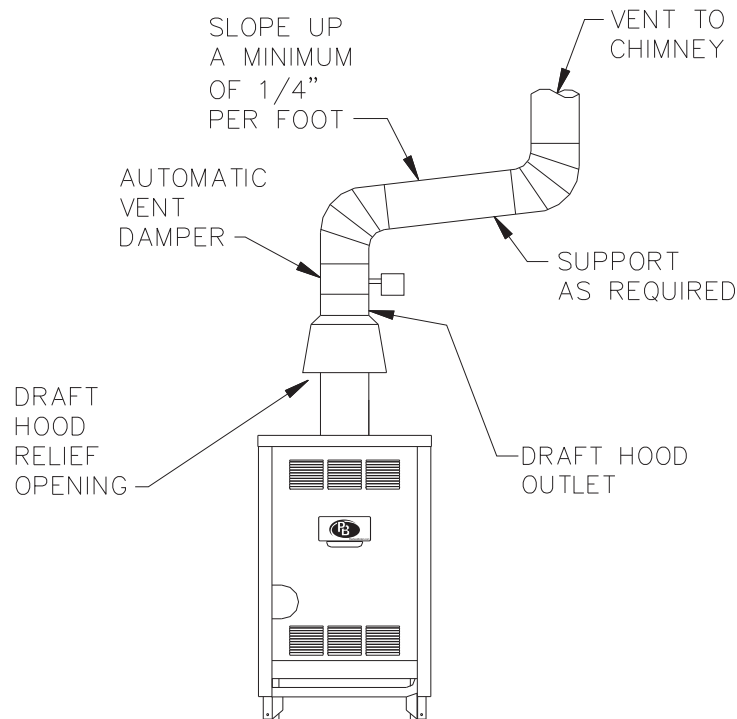

Figure 4.3: Venting with Vent Damper in Vertical Position

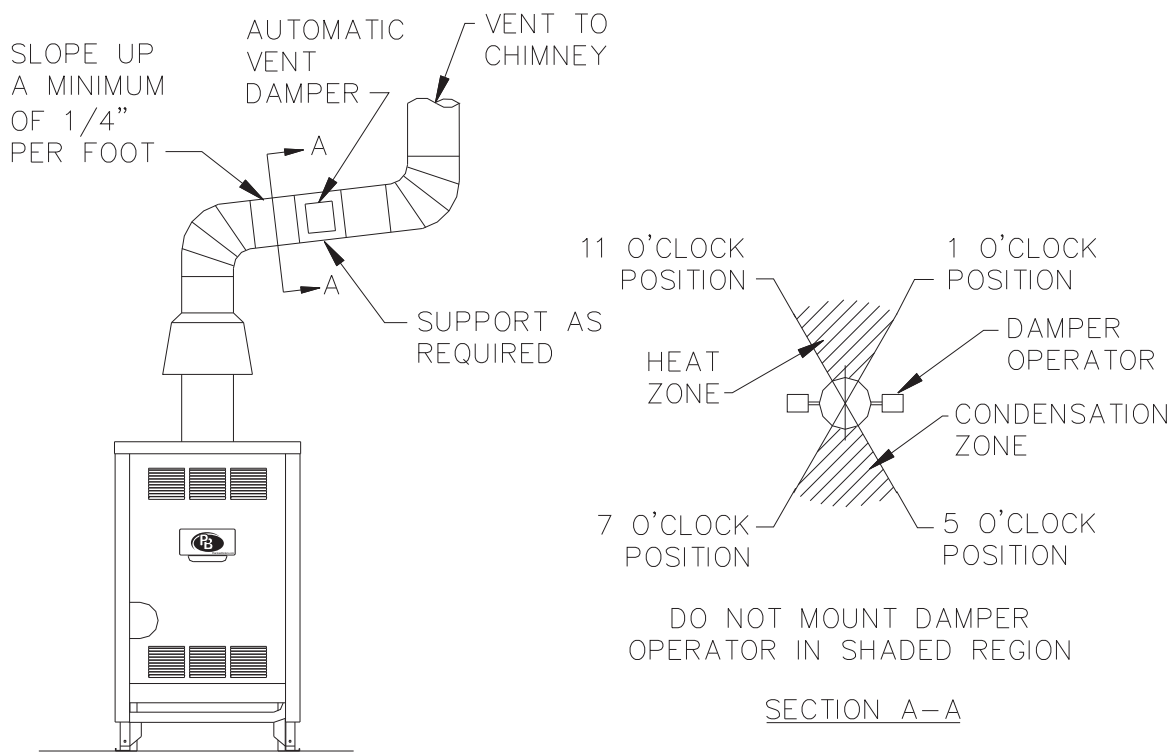

Figure 4.4: Venting with Vent Damper in Horizontal Position

D. BOILER REMOVAL FROM COMMON VENTING SYSTEM

At the time of removal of an existing boiler, follow these steps with each appliance remaining connected to the common venting system placed in operation, while the other appliances remaining connected to the common venting system are not in operation:

Au moment de retirer une chaudière existante, il est important de suivre les étapes suivantes pour chaque appareil raccordé au système d'évacuation commun qui sont en service, alors que les autres appareils demeurant raccordés au système d'évacuation commun ne sont pas en service :

- Seal any unused openings in the common venting system.
Sceller toute ouverture du système d'évacuation commun non utilisée.
- Visually inspect the venting system for proper size and horizontal pitch and determine there is no blockage or restriction, leakage, corrosion and other deficiencies which could cause an unsafe condition.
Effectuer un contrôle visuel du système d'évacuation pour vérifier la taille et la pente horizontale et s'assurer qu'il n'existe aucun blocage ou obstruction, fuite, corrosion ni tout autre problème pouvant menacer la sécurité.

- Insofar as is practical, close all building doors and windows and all doors between the space in which the appliances remaining connected to the common venting system are located and other spaces of the building. Turn on any clothes dryers and any appliance not connected to common venting system. Turn on any exhaust fans, such as range hoods and bathroom exhausts, so they will operate at maximum speed. Do not operate a summer exhaust fan. Close fireplace dampers.

Dans la mesure du possible, fermer toutes les portes et fenêtres de l'immeuble ainsi que toutes les portes entre l'espace dans lequel les appareils qui demeurent raccordés au système d'évacuation commun se trouvent et le reste de l'immeuble. Mettre en marche les sècheuses et tout autre appareil non raccordé au système d'évacuation commun. Mettre en marche tous les ventilateurs aspirant, tels que les hottes de cuisinière et les ventilateurs de salle de bain, en les faisant fonctionner à vitesse maximum. Ne pas faire fonctionner les ventilateurs aspirant d'été. Fermer les registres de foyers.

- d. Place in operation the appliance being inspected. Follow the lighting instructions. Adjust thermostat so appliance will operate continuously.

Mettre en service l'appareil à inspecter. Suivre les instructions concernant l'allumage. Régler le thermostat afin que l'appareil fonctionne sans arrêt.

- e. Test for spillage at the draft hood relief opening after 5 minutes of main burner operation. Use the flame of a match or candle, or smoke from a cigarette, cigar, or pipe.

Vérifier toute fuite à l'orifice de décharge du coupe-tirage après que le brûleur ait fonctionné pendant 5 minutes. Utiliser la flamme d'une allumette ou d'une chandelle ou encore la fumée d'une cigarette, d'un cigare ou d'une pipe.

- f. After it has been determined that each appliance remaining connected to the common venting system properly vents when tested as outlined above, return doors, windows, exhaust fans, fireplace dampers and any other gas-burning appliance to their previous conditions of use.

Après avoir établi que les résidus de combustion de chaque appareil qui demeure raccordé au système commun sont adéquatement évacués lorsque soumis au test décrit ci-dessus, remettre en place les portes, fenêtres, portes intérieures, ventilateurs aspirants, registres de foyer et appareils fonctionnant au gaz.

- g. Any improper operation of the common venting system should be corrected so that the installation conforms with the current edition of the *National Fuel Gas Code*, ANSI Z223.1/NFPA 54 and/or CAN/CSA B149.1, *Natural Gas and Propane Installation Code*. When resizing any portion of the common venting system, the common venting system should be resized to approach the minimum size as determined using the appropriate tables in the *National Fuel Gas Code*, ANSI Z223.1/NFPA 54 and/or CAN/CSA B149.1, *Natural Gas and Propane Installation Code*.

Tout fonctionnement inadéquat du système d'évacuation commun doit être corrigé de manière à respecter les normes du **National Fuel Gas Code**, ANSI Z223.1/NFPA 54 et/ou des Codes d'installation CAN/ACG B149. Lorsqu'il est nécessaire de modifier les dimensions de toute portion du système d'évacuation commun, ces dernières doivent être modifiées de manière à respecter les dimensions minimums indiquées dans les tableaux du chapitre « Sizing of Category I Venting Systems » du **National Fuel Gas Code**, ANSI Z223.1/NFPA 54 ou des Codes d'installation CAN/ACG B149.

5. GAS PIPING

1. Size and install the gas supply piping to provide a supply of gas sufficient to meet the maximum demand of all appliances without undue loss of pressure between the meter and the boiler.
Maximum permissible gas supply pressure to the boiler is 13.5 inches (3.4 kPa) water column.
2. Determine the volume of gas to be provided to the boiler. Obtain this value by dividing the Btu per hour (Watts) rating (on the boiler rating plate) by the heating value of the gas in Btu per cubic feet (Joules per cubic meter). Obtain the heating value of the gas from the gas supplier. As an alternative, use Table 5.1 to obtain the volume of gas to be provided to the boiler.

Table 5.1: Input

Model	Natural Gas		LP Gas	
	(Cubic Feet Per Hour)	(Cubic Meter Per Hour)	(Cubic Feet Per Hour)	(Cubic Meter Per Hour)
GM-05	228	6.5	91	2.6
GM-06	285	8.1	114	3.2
GM-07	342	9.7	137	3.9
GM-08	399	11.3	160	4.5

Natural gas based on 1000 Btu/Cubic Foot (37,300 kJ/m³).
LP gas based on 2,500 Btu/Cubic Foot (93,145 kJ/m³).

3. Table 5.2 shows the maximum flow capacity of several pipe sizes based on 0.3" w.c. (.08 kPa) of water pressure drop. These values are based on a specific gravity of 0.60. Apply the factors indicated in Table 5.3 for gas with specific gravity other than 0.60 to obtain corrected capacities.

Table 5.2: Capacity of Schedule 40 Pipe

Capacity of Schedule 40 pipe [cu. ft. per hour (cu. m per hour)] with pressure drop of 0.3 in. (75 Pa) and specific gravity of 0.60. No allowance for an ordinary number of fittings is required.

Pipe Length Feet	3/4" Pipe		1" Pipe		1-1/4" Pipe		1-1/2" Pipe	
	ft. ³	m ³	ft. ³	m ³	ft. ³	m ³	ft. ³	m ³
10	278	7.8	520	15	1,050	30	1,600	45
20	190	5.4	350	9.9	730	21	1,100	31
30	152	4.3	285	8.1	590	17	890	25
40	130	3.7	245	6.9	500	14	760	22
50	115	3.3	215	6.1	440	12	670	19
60	105	3.0	195	5.5	400	11	610	17

Table 5.3: Maximum Capacity Correction Factors Specific Gravity other than 0.60

Specific Gravity	0.50	0.55	0.60	0.65	0.70	0.75
Correction Factor	1.10	1.04	1.00	0.96	0.93	0.90
Specific Gravity	0.80	0.85	0.90	1.00	1.10	1.20
Correction Factor	0.87	0.84	0.82	0.78	0.74	0.71
Specific Gravity	1.30	1.40	1.50	1.60	1.70	1.80
Correction Factor	0.68	0.66	0.63	0.61	0.59	0.58

4. Connection of boiler to the gas piping system may be made on the left side or top of the boiler. See Figure 11.1 for jacket opening locations.

⚠ WARNING

Use a pipe joint sealing compound that is resistant to the action of liquefied petroleum gas. A non-resistant compound may lose sealing ability in the presence of this gas, resulting in a gas leak and fire or explosion potential.

5. Install a sediment trap. See Figure 5.1. Locate a tee in the drop pipe at same elevation as the gas inlet connection to the boiler. Extend the drop pipe to a pipe cap. As an alternate, the sediment trap may be located in the boiler vestibule. See Figure 5.2.
6. Install a ground joint union ahead of the gas control assembly to permit servicing of the control. Some local codes require an additional equipment shutoff valve when using the combination gas controls. If your code requires such a valve, a suggested location is shown in Figure 5.1 or 5.2.
7. Check piping for leaks. Use an approved gas detector, a non-corrosive leak detection fluid or other leak detection method. If leaks are found, turn off all gas flow and repair as necessary.

⚠ WARNING

When checking for leaks, do not use matches, candles, open flames or other methods that provide a source of ignition. This can ignite a gas leak, resulting in fire or explosion.

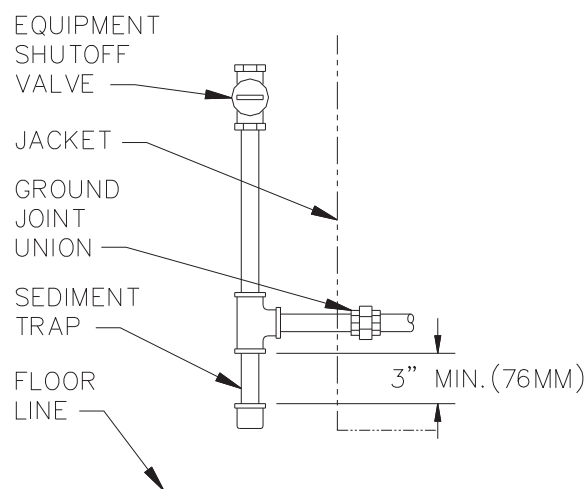

Figure 5.1: Gas Connection to Boiler - External

- Disconnect the boiler and its individual shut-off valve from the gas supply piping system during any pressure testing of that system at test pressure in excess of 1/2 psig (3.5 kPa).

⚠ CAUTION

Do not subject the gas valve to more than 1/2 psi pressure (3.5 kPa). Doing so may damage the valve.

Isolate the boiler from the gas supply piping system by closing its individual service valve during any pressure testing of the gas supply piping system at test pressure equal to or less than 1/2 psig (3.5 kPa).

- Minimum permissible natural gas supply pressure Inches Water Column (kPa):

<u>GM-05</u>	<u>GM-06</u>	<u>GM-07</u>	<u>GM-08</u>
In. kPa	In. kPa	In. kPa	In. kPa
4.5 1.1	4.5 1.1	4.6 1.1	4.9 1.2

Minimum permissible LP gas supply pressure is 11.0" w.c. (2.7 kPa).

- Maximum permissible supply pressure to the boiler [Inches Water Column (kPa)]:

All models 13.5" (3.4 kPa)

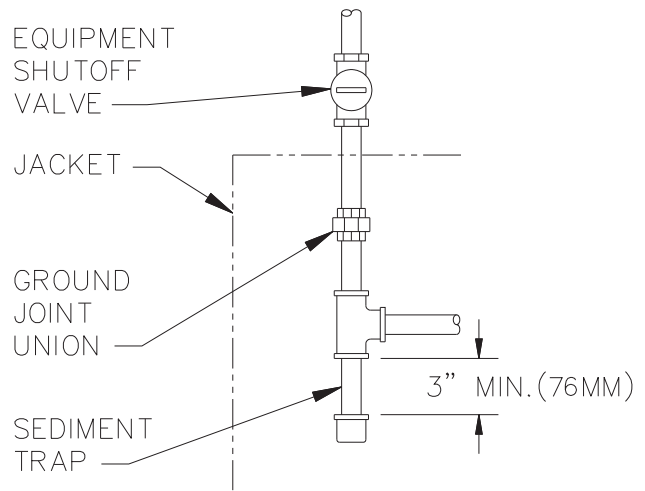

Figure 5.2: Gas Connection to Boiler - Internal

6. ELECTRICAL

This boiler is equipped with a water temperature limit control which includes a low water cutoff function and also a reset feature as described below. It is also equipped with a spark ignited intermittent ignition system. See vendor information in the boiler folder for additional information regarding the boiler controls.

IMPORTANT

In accordance with Section 325 (f) (3) of the Energy Policy and Conservation Act, this boiler is equipped with a feature that saves energy by reducing the boiler water temperature as the heating load decreases. This feature is equipped with an override which is provided primarily to permit the use of an external energy management system that serves the same function.

THIS OVERRIDE MUST NOT BE USED UNLESS AT LEAST ONE OF THE FOLLOWING CONDITIONS IS TRUE:

- An external energy management system is installed that reduces the boiler water temperature as the heating load decreases.
- This boiler is not used for any space heating
- This boiler is part of a modular or multiple boiler system having a total input of 300,000 BTU/hr or greater.
- This boiler is equipped with a tankless coil.

NOTICE

This unit when installed must be electrically grounded in accordance with the requirements of the authority having jurisdiction or, in the absence of such requirements, with the current edition of the *National Electrical Code*, ANSI/NFPA 70 or the Canadian Electrical Code Part I, CSA C22.1, Electrical Code.

A. WIRING

1. See Figure 6.1 for location of wiring and controls. Use Figures 6.2 - 6.3 to connect the boiler to a power supply and then connect components to the boiler.
2. Connect the boiler to a separate, permanently live electrical supply line with a fused switch.
3. Connect the vent damper harness to the polarized connector in the limit control – see Figure 6.1 and vendor instructions.

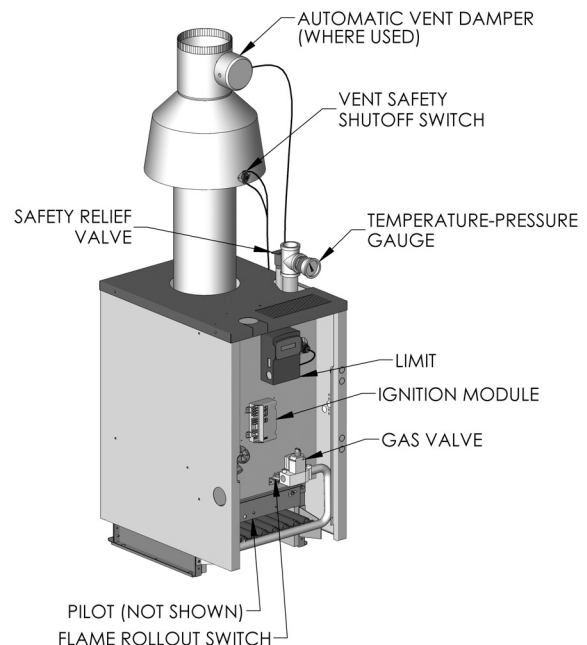

Figure 6.1: Wiring Details

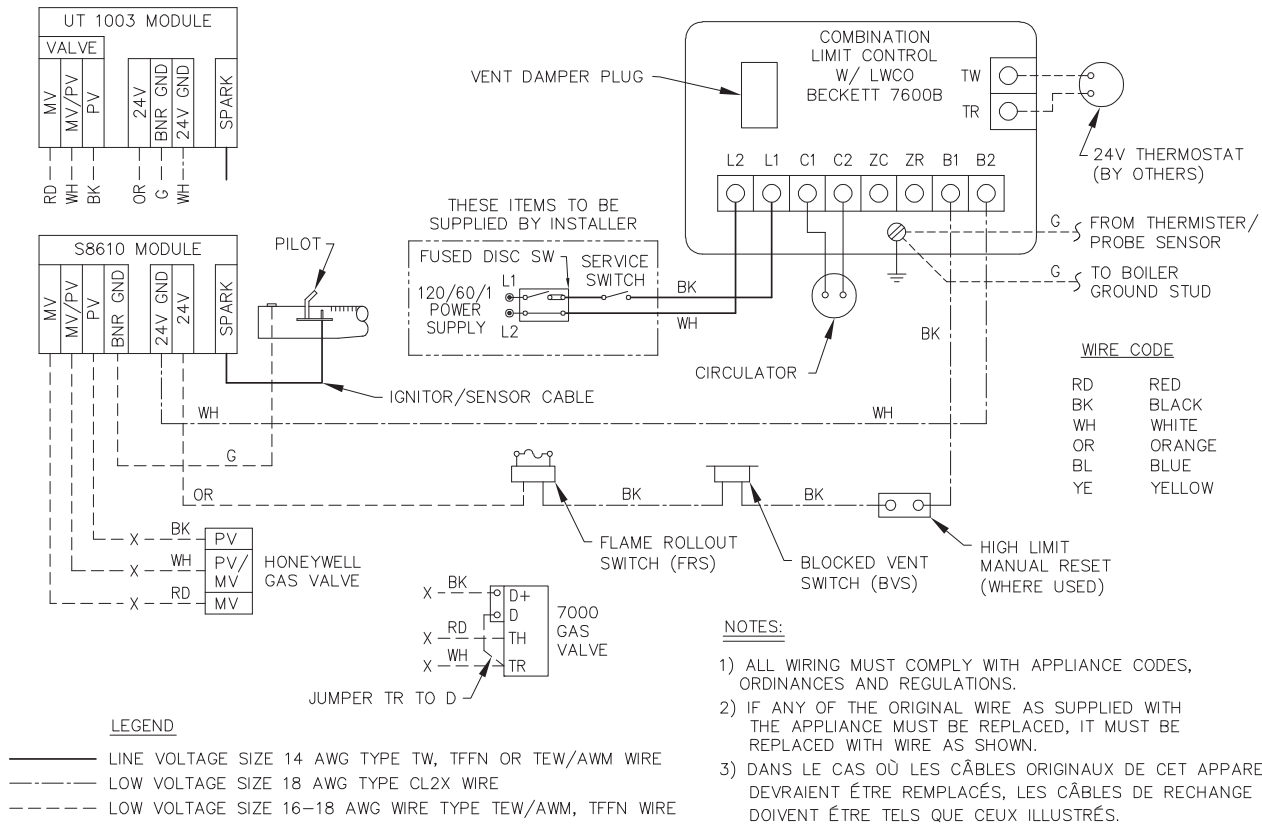

Figure 6.2: Wiring Diagram, Spark Ignited Pilot, Becket7600 Limit Control

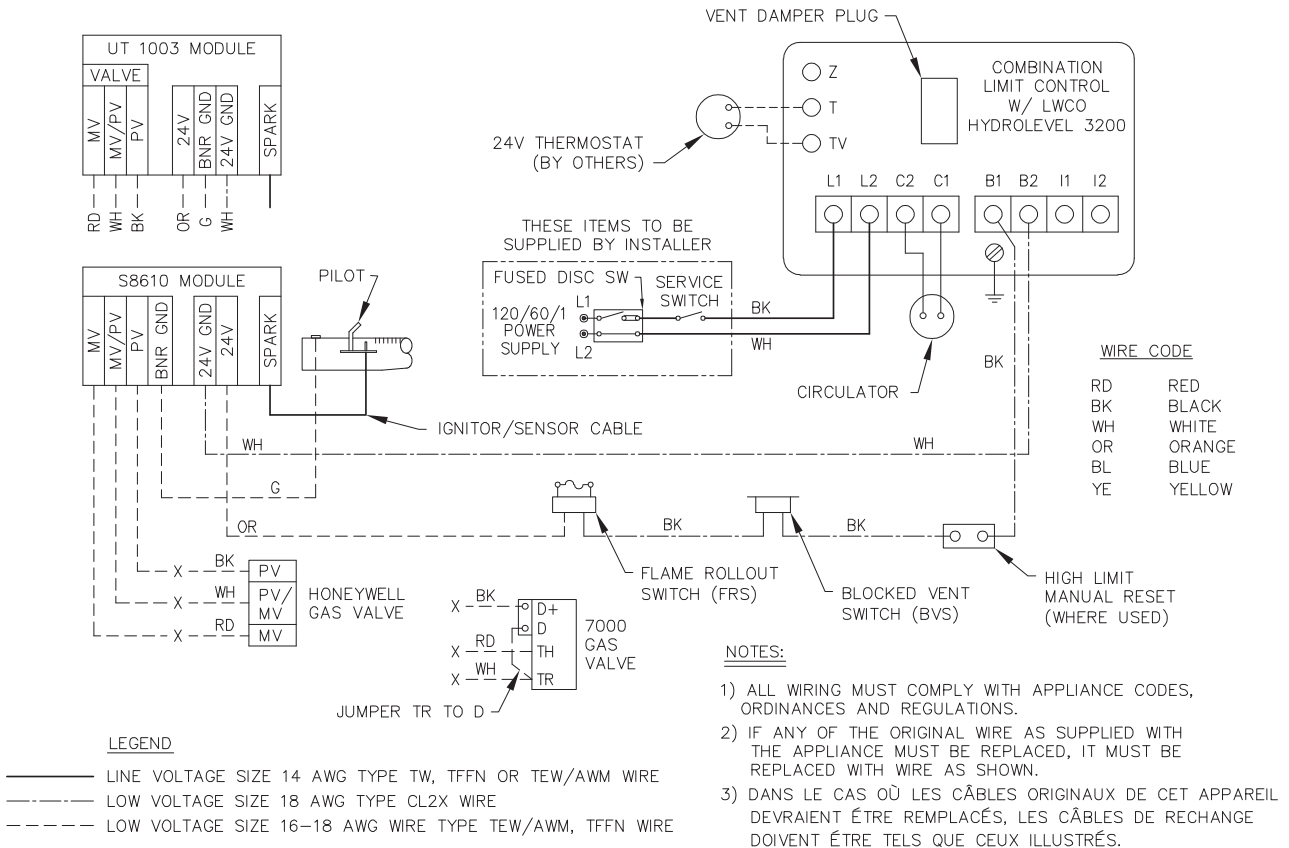

Figure 6.3: Wiring Diagram, Spark Ignited Pilot, Hydrolevel 3200 Limit control

**B. SEQUENCE OF OPERATION,
INTERMITTENT IGNITION**

1. Thermostat calls for heat.
 2. Limit senses boiler water temperature. Prevents operation until water temperature falls approximately 15°F (9°C) below the cut-out temperature.
 3. Automatic vent damper (if used) opens. Damper must be in open position when appliance main burner(s) is operating.
 4. Gas valve energizes.
 - a. Igniter on.
 - b. Pilot gas on, igniting pilot.
 5. Pilot flame detected.
 - a. Igniter off.
 - b. Main gas on, igniting main burners.
- Note: If the pilot is not detected within 90 seconds, the igniter and pilot gas are turned off for 5 minutes. The sequence then resumes at Step 4a.
6. Call for heat ends.
 - a. Pilot and main gas off, extinguishing pilot and main burners.
 - b. Automatic vent damper (if used) closes.

7. CSD CODE REQUIREMENTS

A. GENERAL

This section is in regard to requirements of the ASME CSD-1 Code, Controls and Safety Devices for Automatically Fired Boilers, which may be in effect in your area. Any omissions or discrepancies that may exist between these instructions and the CSD-1 code itself, the code itself takes precedence. The CSD-1 Code may be ordered by calling 1-800-THE-ASME.

B. CSD PART CF REQUIREMENTS

The Series GM™ is CSA certified to ANSI Z21.13 (CSA 4.9) and as such meets all CSD-1 Part CF requirements for combustion side controls for units under 400,000 btuh (117 kW) input. No other combustion side controls are required to meet CSD-1.

C. CSD PART CW REQUIREMENTS

CSD-1 requires the following waterside controls to be installed with the boiler:

1. Manual reset low water cut-off (LWCO), such as Hydrolevel 550SV Probe (29028)
2. Manual reset high limit, such as Honeywell L4006E1117 (50536).

Install these controls in the supply piping. Figures 7.1-7.3 show typical piping using a probe style low water cut-off.

See CSD-1 code for requirements when using a float type low water cut-off.

No valves are allowed between these controls and the boiler supply connection.

Low water cut-off must be positioned higher than the top of the boiler. Follow all instructions furnished by the control manufacturers.

D. CSD MODULAR AND MULTIPLE BOILER REQUIREMENTS

1. Modular Boilers
 - a. CSD-1 requires a manual reset low water cut-off and manual reset high limit to control the modular boiler system. The individual boiler modules are not required to have a low water cut-off or manual reset high limit.
 - b. To be considered a modular boiler system, the individual boiler modules are not allowed to be isolated from the main headers and controls with stop valves.

2. Multiple Boilers

CSD-1 requires a manual reset low water cut-off and manual reset high limit on each individual boiler.

For more information on modular and multiple boiler systems, see the Flex-Heat manual or contact PB Heat.

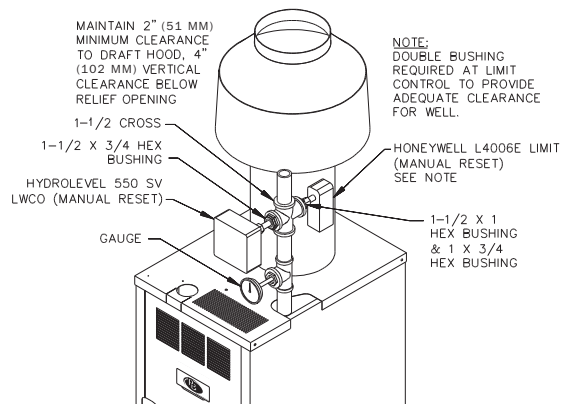

Figure 7.1: CSD Piping, Using Cross Fitting

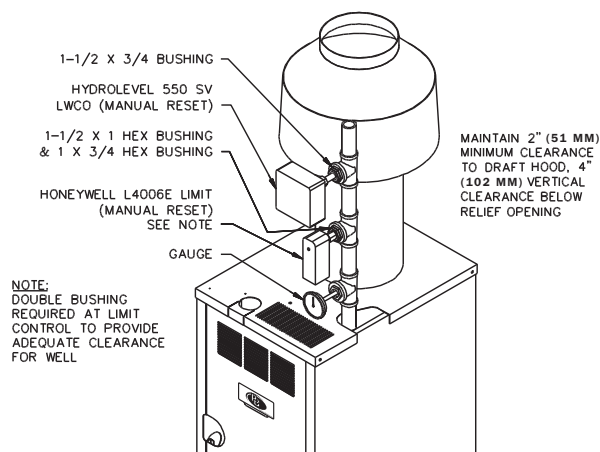

Figure 7.2: CSD Piping, Vertical Using Tee's

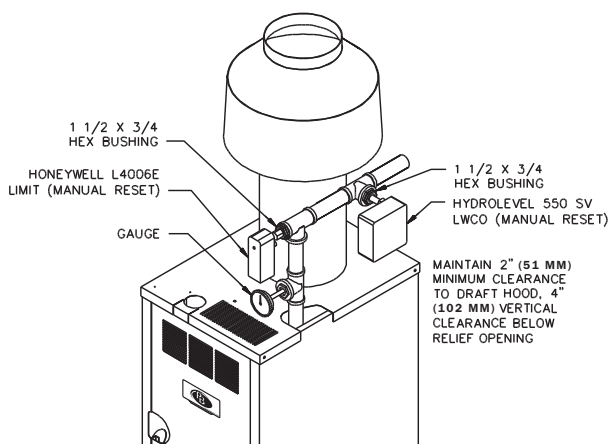

Figure 7.3: CSD Piping, Horizontal

**E. CSD PART CE ELECTRICAL
REQUIREMENTS**

Note the following electrical requirements per CSD-1 Section CE-110(a):

“A disconnecting means capable of being locked in the open position shall be installed at an accessible location at the boiler so that the boiler can be disconnected from all sources of potential. This disconnecting means shall be an integral part of the boiler or adjacent to it.”

“A manually operated remote shutdown switch or circuit breaker shall be located just outside the boiler room door and marked for easy identification. Consideration should be given to the type and location of the switch to safeguard against tampering. If the boiler room door is on the building exterior, the switch should be located just inside the door. If there is more than one door to the boiler room, there should be a switch located at each door.”

“The emergency shutdown switch or circuit breaker must disconnect all power to the burner controls.”

8. START-UP PROCEDURES

A. COMPLETING THE INSTALLATION

1. Confirm that all water, gas and electricity are turned off.
2. Inspect the boiler combustion chamber for foreign objects and remove if present.
3. Check physical condition of burners and pilot. Make certain that there are no unusual bends or perforations in the burners or pilot. Replace components if necessary.
4. Verify that water piping, venting, gas piping and electrical wiring and components are installed properly. Refer back to previous sections of these instructions as well as equipment manufacturer's instructions as necessary.
5. Fill the boiler and system with water, making certain to vent all air from all points in the system. To check water level in the system, open and close each vent in the system. Water should exit from each vent when it is opened.
6. The pressure reducing valve on the fill line will typically allow the system to be filled and pressurized to 12 psi (83 kPa). Consult the valve and expansion tank manufacturer for more specific information.
7. Check joints and fittings throughout the system for leaks. If leaks are found, drain the system and repair as required.
8. Connect a manometer to 1/8 NPT tapping provided on the manifold. See Figure 8.1.
9. Confirm that the gas supply pressure to the boiler is above the minimum and below the maximum values for the gas being used. See the end of Section 5 for these values. If a supply pressure check is required, isolate the boiler and gas valve before performing the pressure check. If the supply pressure is too high or too low, contact the gas supplier.
10. Turn on electricity and gas to boiler.
11. Light the boiler by following the Lighting/Operating Instructions label mounted to the jacket panel. The initial ignition may require several tries as the piping is purged of air.
12. Use the sequence descriptions in Section 6, paragraph B (Electrical) to follow light-off and shutdown sequences and to assist in diagnosing problems. If the boiler does not function properly, consult Section 9, Troubleshooting.
13. The gas manifold and control assembly provided with this boiler meet with all criteria regarding safe lighting and performance as specified in ANSI Z21.13 (CSA 4.9), *Gas-Fired Low-Pressure Steam and Hot Water Boilers*. The gas manifold and control assembly are made of gas-tight, completely factory assembled and installed components of the base assembly. See Figure 8.1.

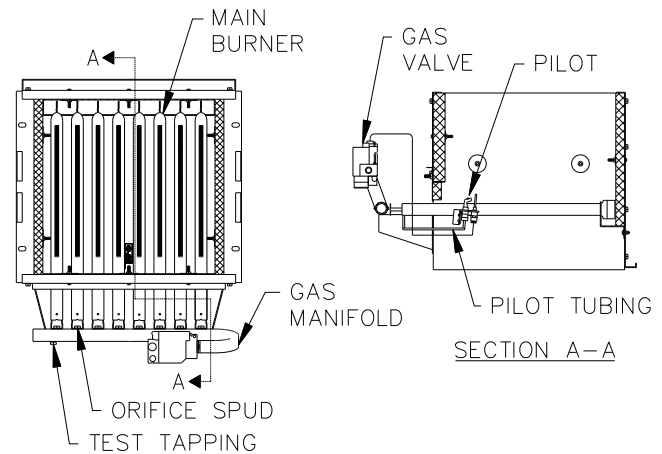

Figure 8.1: Gas, Valve, Manifold and Burner Assembly

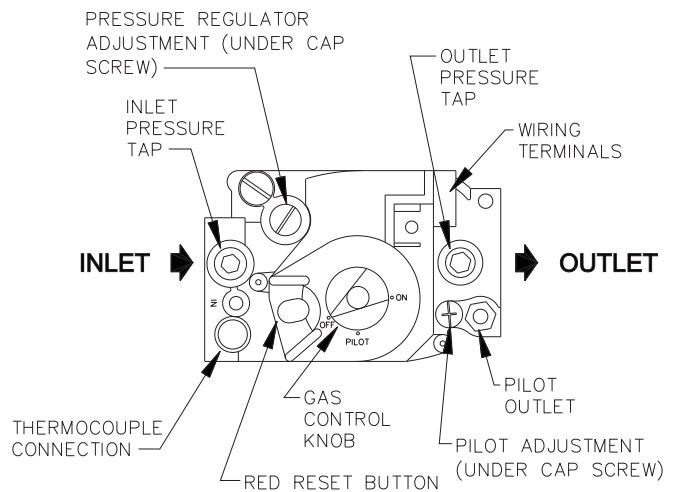

Figure 8.2: Valve Tapping and Adjustment Screw Locations

FOR YOUR SAFETY READ BEFORE LIGHTING

WARNING: If you do not follow these instructions exactly, a fire or explosion may result causing property damage, personal injury, or loss of life.

- A. This appliance is equipped with an ignition device which automatically lights the pilot. Do not try to light the pilot by hand.
 - Immediately call your gas supplier from a neighbor's phone. Follow the gas supplier's instructions.
 - B. **BEFORE OPERATING** smell all around the appliance area for gas. Be sure to smell next to the floor because some gas is heavier than air and will settle on the floor.
 - If you cannot reach your gas supplier, call the fire department.
- WHAT TO DO IF YOU SMELL GAS**
- Do not try to light any appliance
 - Do not touch any electric switch; do not use any phone in your building.
- C. Use only your hand to push in or turn the gas control knob. Never use tools. If the knob will not push in or turn by hand, don't try to repair it, call a qualified service technician. Force or attempted repair may result in a fire or explosion.
 - D. Do not use this appliance if any part has been under water. Immediately call a qualified service technician to inspect the appliance and to replace any part of the control system and any gas control which has been under water.

OPERATING INSTRUCTIONS

1. **STOP!** Read the safety information above on this label.
2. Set the thermostat or operating control to lowest setting.
3. Turn off all electric power to the appliance.
4. This appliance is equipped with an ignition device which automatically lights the pilot. Do not try to light the pilot by hand.
5. If the gas valve is not visible, remove control access panel.
6. If the gas control knob is not in the "OFF" position, turn the knob clockwise ↻ to "OFF".
7. Wait five (5) minutes to clear out any gas. Then smell for gas, including near the floor. If you smell gas, **STOP!** Follow "B" in the safety information above on this label. If you don't smell gas, go to the next step.
8. Turn the gas control knob counterclockwise ↶ to "ON".
9. Replace control access panel, if applicable.
10. Turn on all electrical power to the appliance.
11. Set thermostat or operating control to desired setting.
12. If the appliance will not operate, follow the instructions "To Turn Off Gas To Appliance" and call your service technician or gas supplier.

Gas Control Knob (shown in "OFF" position)

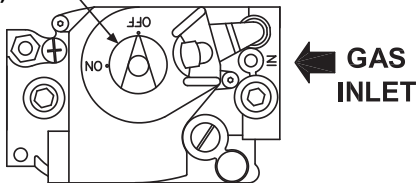

TO TURN OFF GAS TO APPLIANCE

1. Set the thermostat or operating control to lowest setting.
2. Turn off all electric power to the appliance if service is to be performed.
3. If the gas valve is not visible, remove the control access panel.
4. Turn the gas control knob clockwise ↻ to "OFF".
5. Replace control access panel, if applicable.

HSP VR8204/VR8304 9181R REV.1

Figure 8.3: Operating Instructions, Spark Intermittent Ignition

POUR VOTRE SÉCURITÉ, LISEZ AVANT L'ALLUMAGE

MISE EN GARDE: Négliger de suivre ces instructions à la lettre pourrait provoquer un incendie ou une explosion causant des dégâts matériels, des blessures ou la mort.

- A. Cet appareil est muni d'un dispositif d'allumage automatique de la veilleuse. Ne tentez pas d'allumer la veilleuse à la main.
- B. **AVANT DE METTRE EN MARCHÉ**, sentez autour de l'appareil pour détecter toute odeur de gaz. Étant donné que certains gaz sont plus lourds que l'air et se déposent sur le sol, s'assurer de bien sentir près du plancher.
- QUE FAIRE SI VOUS DÉTECTEZ UNE ODEUR DE GAZ**
 - Ne pas tenter d'allumer l'appareil
 - Ne toucher à aucun interrupteur électrique; n'utiliser aucun appareil téléphonique dans l'immeuble.
 - Contactez immédiatement votre fournisseur de gaz à partir du téléphone d'un voisin. Suivre les instructions données par votre fournisseur de gaz.
- S'il est impossible de rejoindre le fournisseur de gaz, appeler le service des incendies.
- C. N'utilisez que votre main pour appuyer ou tourner le bouton de commande du gaz. Ne jamais utiliser d'outils. S'il est impossible d'enfoncer ou de tourner le bouton à la main, ne tentez pas de le réparer. Appelez un technicien d'entretien qualifié. Une force excessive ou une tentative de réparation peut provoquer un incendie ou une explosion.
- D. N'utilisez pas cet appareil ni aucune de ses pièces si elles ont été immergées. Contactez immédiatement un technicien d'entretien qualifié pour inspecter l'appareil et remplacer toute pièce du système de régulation du débit gazeux et toute commande de gaz ayant été immergée.

DIRECTIVES DE FONCTIONNEMENT

1. **ARRÊTEZ!** Lisez les consignes de sécurité plus haut sur cette étiquette.
2. Réglez le thermostat ou l'appareil de réglage au niveau le plus bas.
3. Coupez toute l'alimentation électrique de l'appareil.
4. Cet appareil est muni d'un dispositif d'allumage automatique de veilleuse. Ne tentez pas d'allumer la veilleuse à la main.
5. Si la soupape d'alimentation en gaz n'est pas visible, retirez le panneau d'accès.
6. Si le bouton de commande du gaz n'est pas en position « OFF », tournez le bouton dans le sens des aiguilles d'une montre U pour les mettre à « OFF ».
7. Attendre cinq (5) minutes pour que tout le gaz présent puisse s'échapper. Sentir autour de l'appareil pour détecter toute odeur de gaz, incluant près du sol. Si vous sentez une odeur de gaz, **ARRÊTEZ!** Suivez les consignes de sécurité apparaissant en « B » plus haut sur cette étiquette. Si vous ne détectez aucune odeur de gaz, passez à l'étape suivante.
8. Tournez le bouton de commande dans le sens contraire des aiguilles d'une montre U pour le mettre en position de marche « ON ».
9. Remplacez le panneau d'accès du régulateur de débit, le cas échéant.
10. Remettez en marche toute l'alimentation électrique de l'appareil.
11. Réglez le thermostat ou l'appareil de réglage au niveau désiré.
12. Si l'appareil ne se met pas en marche, suivez les instructions ci-dessous : « Couper l'alimentation en gaz de l'appareil » et appelez votre technicien d'entretien ou fournisseur de gaz.

Bouton de contrôle du débit (illustré en position d'arrêt « OFF »)

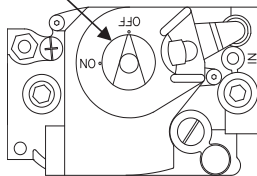

← ARRIVÉE DE GAZ

COUPER L'ALIMENTATION EN GAZ DE L'APPAREIL

1. Réglez le thermostat ou l'appareil de réglage au niveau le plus bas.
2. Si des travaux d'entretien doivent être effectués, couper toute l'alimentation électrique de l'appareil.
3. Si la soupape d'alimentation en gaz n'est pas visible, retirez le panneau d'accès.
4. Tournez le bouton de commande dans le sens des aiguilles d'une montre U pour les mettre en position d'arrêt « OFF ».
5. Remplacez le panneau d'accès du régulateur de débit, le cas échéant.

HSP VR8204/VR8304 9414 REV 0 (MM/AA)

Figure 8.4: Operating Instructions, Spark Intermittent Ignition

B. CONTROL DESCRIPTIONS

See Figure 8.5 for locations of these devices.

1. **FLAME ROLLOUT SAFETY SHUTOFF SWITCH** – A thermally activated switch located above the burners on the inner front jacket panel. The flame rollout safety shutoff switch will sense excessive temperature caused by continued flame rollout and shut down main burner gas. This is a non-recycling switch that must be replaced once activated.
2. **VENT SAFETY SHUTOFF SWITCH** – A thermally activated, manually resettable switch located on the draft hood. If venting system becomes partially or totally blocked, the vent safety shutoff switch will sense excessive temperature caused by flue products exiting the draft hood relief opening and shut down main burner gas.
3. **LIMIT CONTROL/LOW WATER CUTOFF** – A thermally activated, manually adjustable switch located in the upper right side of boiler vestibule. The limit senses supply water temperature and will shut down main burner gas if the supply water exceeds the preset temperature limit. This is a recycling switch that will automatically reset when the supply water falls below the preset temperature.

The control will also shut down the main burner gas if the water level drops below the control's location.

C. ADJUSTMENT OF GAS PRESSURE REGULATOR

1. Using the manometer setup installed in part 8A, set manifold pressure.
2. To adjust gas pressure, turn adjusting screw of gas pressure regulator counterclockwise to decrease pressure, clockwise to increase pressure. Refer to Figure 8.2 for location of gas pressure regulator. Replace the cap screw when adjustment is complete.
3. In no case should the final manifold pressure vary more than ±0.3 inches (±75 Pa) water column from the above specified pressures. Any necessary major changes in the flow should be made by changing the size of the burner orifice spuds.
4. When adjustment is complete, turn off boiler, gas flow and electricity to boiler. Remove manometer connection from valve and plug tapping with plug provided. Turn utilities back on and resume checkout.

D. CHECKING BURNER INPUT

1. Refer to rating label mounted on the jacket top panel to obtain the rated BTU (kW) per hour input. In no case shall the input to the boiler exceed the value shown on the rating label.
2. Check input by use of the following formula [PB Heat suggests reading meter for 2 Cu. Ft. (.05 Cu. Meter)]:

$$\text{BTU/Hr. Input} = \frac{3600 \times F \times H}{T}$$

- 3600 – Seconds per hour
- F – Cubic Feet of Gas Registered on Meter
- H – Heat Value of Gas in BTU/Cubic Feet
- T – Time in Seconds the Meter is Read

(Metric) Determine the input by multiplying “F” – Meter Reading (Cubic Meters of Gas) times “H” – Heating Value of Gas (Joules per Cubic Meter). Divide by “T” – the time in seconds of the meter reading.

$$\text{Rate, Watts} = \frac{F \times H}{T}$$

3. As an alternative, use Table 8.1. Use the heating value provided by gas supplier. Use a stopwatch to record the time it takes for 2 cubic feet (.05 cubic meter) of gas to pass through the meter. Read across and down to determine rate.

The control will also shut down the main burner gas if the water level drops below the control's location.

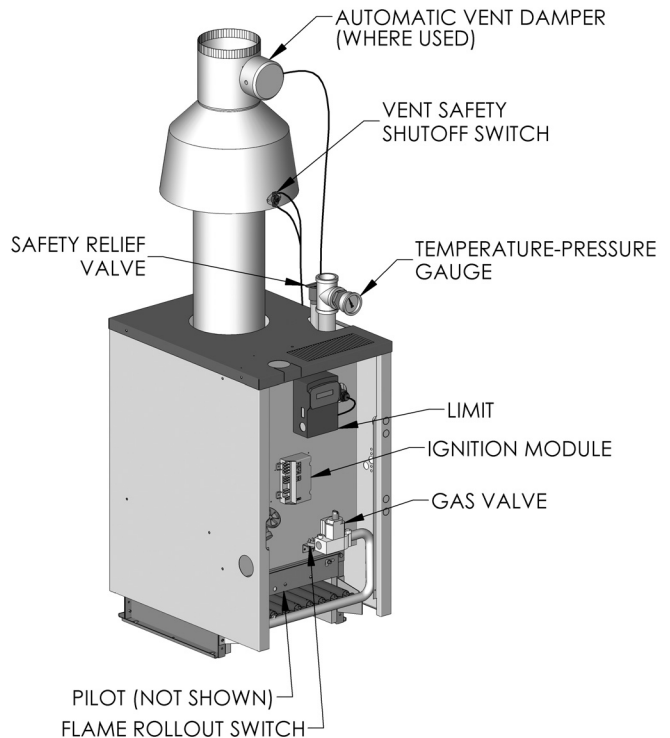

Figure 8.5: Control Locations

START-UP PROCEDURES

Table 8.1a: Meter Conversion – Natural Gas

Burner inputs in Btu/hr for various meter timings and heat values. (Table based on 2 cubic feet of gas through meter).

Time that meter is read (sec)	Heat Value of Gas (Btu/cubic foot)		
	1,000	1,025	1,050
15	480,000	492,000	504,000
20	360,000	369,000	378,000
25	288,000	295,200	302,400
30	240,000	246,000	252,000
35	205,714	210,857	216,000

Table 8.1b: Meter Conversion – Natural Gas

(Metric) Burner inputs in Watts for various meter timings and heat values. (Table based on .05 cubic meters of gas through meter).

Time that meter is read (sec)	Heat Value of Gas (kJ/cubic meter)		
	37,300	38,200	39,100
15	124,333	127,333	130,333
20	93,250	95,500	97,750
25	74,600	76,400	78,200
30	62,167	63,667	65,167
35	53,286	54,571	55,857

E. CHECK-OUT PROCEDURE

- After starting the boiler, be certain all controls are working properly. Check to be sure that the limit will shut off the boiler in the event of excessive water temperature. This can be done by lowering the limit setting until the main burners shut down. When proper limit function is confirmed, return the dial to its previous setting.
- Intermittent Ignition System—To check operation of the ignition system safety shut-off features:
 - Refer to Figure 8.3 Operating Instructions for placing the boiler in operation and Section 6, paragraph B, Intermittent Ignition System Operating Sequence.
 - Observe boiler operation through one complete cycle.
- Low Water Cut-Off – Consult the manufacturer's instructions for the low water cut-off operational check procedure. Note that low water cut-off feature is incorporated in Beckett 7600B Limit Control and the Hydrolevel 3200 Control.
- Check the system to make sure there are no leaks or overfilling problems which might cause excessive make-up water to be added. Make-up water causes liming in the boiler and brings in oxygen. Oxygen can cause severe damage to the boiler through oxygen corrosion pitting.
- Check the expansion tank and automatic fill valve (if used) to confirm that they are operating correctly. If either of these components causes high pressure in the system, the boiler relief valve will weep or open, allowing fresh water to enter the system.
- Do not allow the system controls to subject the boiler to excessively low water temperatures, which would cause condensation of flue gases and corrosion of the boiler. Operate the boiler at a temperature above 130°F (54°C). Adjust the boiler limit as required to maintain boiler temperature above this level.
- Check the general condition of the system including piping support, joints, etc. Check cleanliness of the radiators, baseboard units and/or convectors. Clean them to the extent possible. If radiators do not heat evenly, vent any remaining air from them.
- Review operation and User's Information Manual with end-user.
- Complete the Warranty Card and submit it to PB Heat.
- Hang the Installation, Operation and Maintenance Manual and User's Information Manual in an accessible position near the boiler.

9. TROUBLESHOOTING

A. SHUT-DOWN CAUSED BY PILOT OUTAGE, VENT SAFETY SHUTOFF SWITCH OR FLAME ROLLOUT SAFETY SHUTOFF SWITCH

In the event of a shut-down caused by a pilot outage, action of the vent safety shutoff switch or flame rollout safety shutoff switch effecting a shut-down of the main burners:

- Refer to the Operating Instructions in Figures 8.3 & 8.4 to properly turn off the gas to the boiler.
- Turn off all electric power to the boiler.
- Call a qualified heating service agency or local gas company and have the cause of the shut-down investigated and corrected.
- Refer to Operating Instructions to re-start boiler.

B. TROUBLESHOOTING GUIDES

Use Table 9.1 to assist in determining causes and providing corrective actions to boiler problems. Refer also to Figure 9.1 to troubleshoot the Intermittent Ignition System Control. These guides must be used only by qualified service technicians. These individuals must follow all applicable codes and regulations in repair of any boiler problems.



DANGER

When servicing or replacing items that communicate with the boiler water, be certain that:

- There is no pressure on the boiler.
- The boiler is not hot.
- The power is off.

When servicing the gas valve or pilot, be certain that:

- The gas is off.
- The electricity is off.



WARNING

Do not use this appliance if any part has been under water. Improper or dangerous operation may result. Immediately call a qualified service technician to inspect the boiler and to replace any part of the control system and any gas control which has been under water.



CAUTION

Label all wires prior to disconnection when servicing controls. Wiring errors can cause improper and dangerous operation. Verify proper operation after servicing.



AVERTISSEMENT

Identifier tous les câbles avant de les débrancher au moment d'effectuer l'entretien des commandes. Des erreurs dans le raccordement des câbles d'alimentation peuvent causer un fonctionnement inadéquat et dangereux. Vérifier le bon fonctionnement après les travaux d'entretien.



CAUTION

Should overheating occur or the gas supply fail to shut off, do not turn off or disconnect the electrical supply to the pump. This may aggravate the problem and increase the likelihood of boiler damage. Instead, shut off the gas supply at a location external to the appliance.

Table 9.1: Boiler Troubleshooting Guide

PROBLEM	POSSIBLE CAUSES	CORRECTIVE ACTIONS
Burners not functioning.	<ol style="list-style-type: none"> 1. No power. 2. Limit not working. 3. Flame rollout switch open. 4. Blocked vent switch open. 5. Gas off at boiler gas valve. 6. Gas off external to boiler. 7. Plugged orifice spuds. 8. Defective gas valve. 9. Improper wiring. 10. Vent damper malfunctioning. 	<ol style="list-style-type: none"> 1. Check line voltage wiring and fuses. 2. Check wiring and contacts, relay, temperature setting. Clean and adjust as necessary. 3. Replace switch. Locate cause and correct. 4. Reset blocked vent switch. Locate cause and correct. 5. Start boiler using Operating Instructions. 6. Check any gas valves in the line. 7. Check, clean and re-install. 8. Use Figure 9.1 to troubleshoot intermittent ignition gas valve. Replace if necessary. 9. Check and correct in accordance with wiring diagrams in Section 6. 10. Refer to vent damper manufacturer's instructions. Replace if necessary.
Burners will not shut down.	<ol style="list-style-type: none"> 1. Defective gas valve. 2. Short circuit. 	<ol style="list-style-type: none"> 1. Use Figure 9.1 to troubleshoot intermittent ignition gas valve. Replace if necessary. 2. Check and correct wiring.
Flashback or burning at orifice spuds.	<ol style="list-style-type: none"> 1. Manifold gas pressure too low. 2. Improperly sized/drilled orifice spuds. 3. Leaking gas valve. 4. Burrs on orifice. 5. Low supply gas pressure. 6. Excessive downdraft or draft problems in boiler room. 	<ol style="list-style-type: none"> 1. Adjust to proper pressure. 2. Install correct spuds. 3. Replace valve. 4. Remove burrs. 5. Contact gas supplier. 6. Check air supply, ventilation and venting system.
Delayed ignition.	<ol style="list-style-type: none"> 1. Insufficient pilot flame. 2. Pilot burner/orifice clogged. 3. Overfiring. 4. Misaligned burners or pilot. 5. Draft problem in boiler room. 	<ol style="list-style-type: none"> 1. Increase pilot gas flow. 2. Clean pilot burner and orifice. 3. Reduce rate to input on rating label. 4. Realign burners or pilot. 5. Check air supply, ventilation and venting system.
Excessive condensation in vent.	<ol style="list-style-type: none"> 1. Underfiring. 2. Limit set too low. 3. Vent pipe too long. 4. Inadequate chimney or venting system. 	<ol style="list-style-type: none"> 1. Increase rate to input on rating label. 2. Reset limit to higher setting. 3. Reposition boiler to reduce length. 4. Check chimney and venting recommendations.
Boiler not heating properly.	<ol style="list-style-type: none"> 1. Underfiring. 2. Limit set too low. 3. Air in system. 4. Circulator malfunctioning. 5. Circulation system clogged. 6. Incorrect thermostat heat anticipator setting. 	<ol style="list-style-type: none"> 1. Increase rate to input on rating label. 2. Reset limit to higher setting. 3. Vent air from all points in system. 4. Check circulator, replace if necessary. 5. Shut down and cool boiler, drain and flush system. 6. Adjust heat anticipator.
Fumes or gas odors.	<ol style="list-style-type: none"> 1. Leaks in gas piping or fittings. 2. Leaks in gas service line or meter. 3. Obstructed chimney. 4. Obstructed flueways or vent. 5. Undersized chimney or vent, high draft loss in vent. 6. Draft problem in boiler room. 7. Overfiring. 8. Vent damper malfunctioning. 	<ol style="list-style-type: none"> 1. Locate and repair or replace. 2. Shut down boiler and notify gas provider. 3. Check, repair and/or clean chimney. 4. Clean flueways or vent and remove obstructions. 5. Check National Fuel Gas Code ANSI Z223.1/NFPA 54 and/or CAN/CGA B149 Installation Codes and vent manufacturer's recommendations. 6. Check air supply, ventilation and venting system. 7. Reduce rate to input on rating label. 8. Refer to vent damper manufacturer's instructions. Replace if necessary.

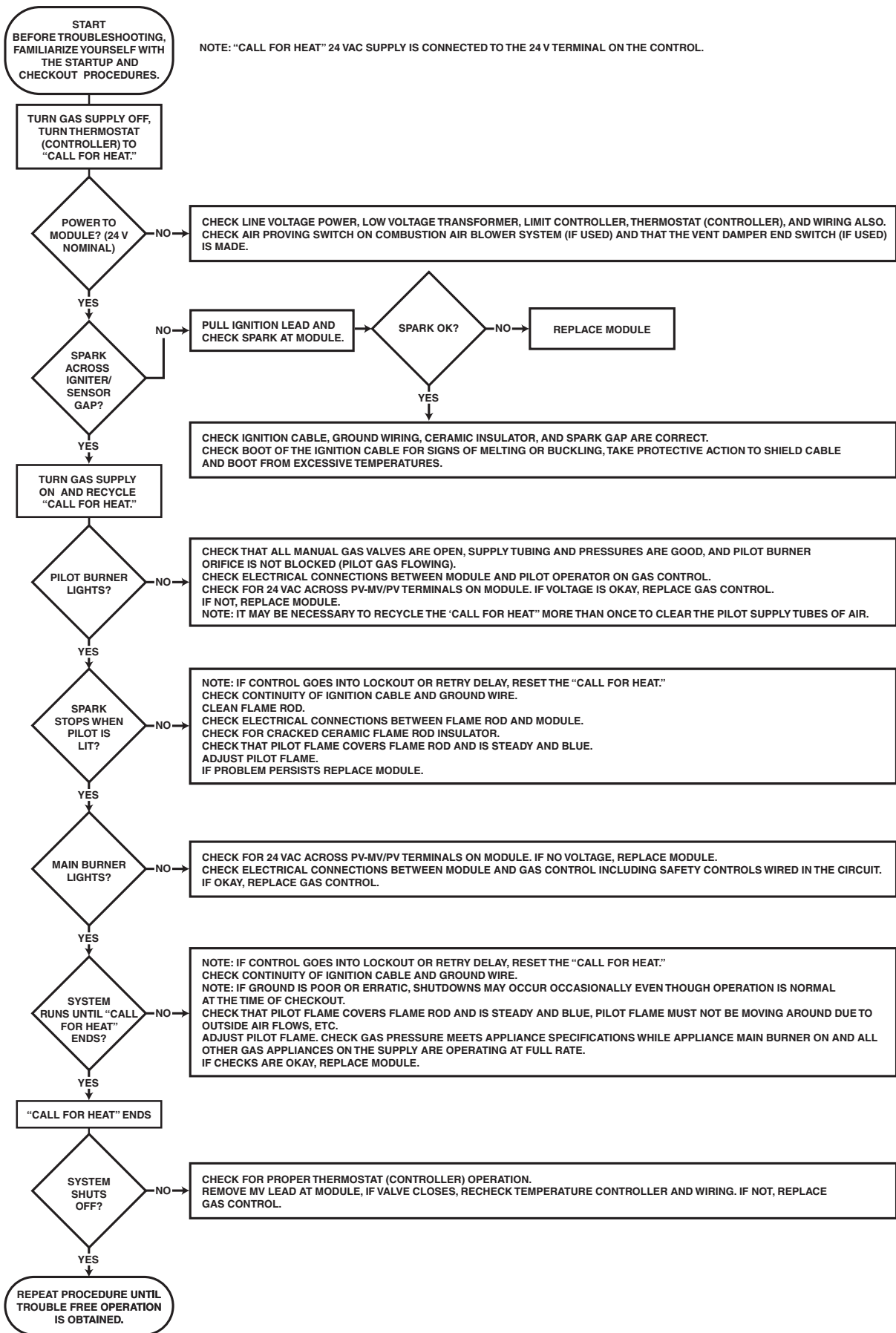

Figure 9.1: Intermittent Ignition System Troubleshooting Sequence

10. MAINTENANCE

WARNING

Product Safety Information Refractory Ceramic Fiber Product

This appliance contains materials made from refractory ceramic fibers (RCF). Airborne RCF, when inhaled, have been classified by the International Agency for Research on Cancer (IARC), as a possible carcinogen to humans. After the RCF materials have been exposed to temperatures above 1800°F (982°C), they can change into crystalline silica, which has been classified by the IARC as carcinogenic to humans. If particles become airborne during service or repair, inhalation of these particles may be hazardous to your health.

Avoid Breathing Fiber Particulates and Dust

Suppliers of RCF recommend the following precautions be taken when handling these materials:

Precautionary Measures:

Provide adequate ventilation.

Wear a NIOSH/MSHA approved respirator.

Wear long sleeved, loose fitting clothing and gloves to prevent skin contact.

Wear eye goggles.

Minimize airborne dust prior to handling and removal by water misting the material and avoiding unnecessary disturbance of materials.

Wash work clothes separately from others. Rinse washer thoroughly after use.

Discard RCF materials by sealing in an airtight plastic bag.

First Aid Procedures:

Inhalation: If breathing difficulty or irritation occurs, move to a location with fresh clean air. Seek immediate medical attention if symptoms persist.

Skin Contact: Wash affected area gently with a mild soap and warm water. Seek immediate medical attention if irritation persists.

Eye Contact: Flush eyes with water for 15 minutes while holding eyelids apart. Do not rub eyes. Seek immediate medical attention if irritation persists.

Ingestion: Drink 1 to 2 glasses of water. Do not induce vomiting. Seek immediate medical attention.

A. GENERAL

1. Disconnect this boiler from the gas supply piping during any pressure testing of the gas system.
2. Check pipes adjacent to cold walls or in unheated spaces. Insulate and tape them if necessary to be sure they can't freeze up. Keeping the water moving at all times will reduce the likelihood of freezing. See Section 3 for antifreeze instructions.
3. If there is considerable foreign matter in the boiler water, the boiler should be shut down and allowed to cool, then drained and thoroughly flushed out. Use the drain valve at the bottom of the return connection to drain the boiler. Pipe the drain cock to a suitable drain or containment device if antifreeze is used. Flush the system to remove remaining matter. If there is evidence that hard scale has formed on the internal surfaces, the boiler should be cleaned by chemical means as prescribed by a qualified water treatment specialist.
4. There must not be signs of continuous wetness at the chimney. If signs of continuous wetness are observed, a qualified service agency must be consulted to modify the vent configuration to prevent the formation of condensate.

B. DAILY (WITH BOILER IN USE)

Daily boiler observation can be performed by the owner. If any potential problems are found, a qualified installer or service technician/agency must be notified.

1. Remove any combustible materials, gasoline and other flammable liquids and substances that generate flammable vapors from the area where the boiler is contained. Make certain that the boiler area has ample air for combustion and ventilation and that there are no obstructions to the free flow of air to and from the boiler.
2. Observe general boiler conditions (unusual noises, vibrations, etc.)
3. Observe operating temperature and pressure on the combination gauge located on the left side of the boiler. Boiler pressure should never be higher than 5 psi (34 kPa) below the rating shown on the safety relief valve [25 psig (172 kPa) maximum for a 30 psig (207 kPa) rating, 45 psig (310 kPa) maximum for a 50 psig (345 kPa) rating]. The valve rating can be found on the top of the safety relief valve (see Figure 3.1 for location of the safety relief valve). Boiler temperature should never be higher than 250°F (121°C).

4. Check for water leaks in boiler and system piping.
5. Smell around the appliance area for gas. If you smell gas, follow the procedure listed in the Lighting/Operating Instructions in Section 8.

C. WEEKLY (WITH BOILER IN USE)

1. Flush float-type low-water cut-off (if used) to remove sediment from the float bowl as stated in the manufacturer's instructions.

D. MONTHLY (WITH BOILER IN USE)

1. Check boiler room floor drains for proper functioning.
2. Check function of the safety relief valve (monthly unless specified otherwise by manufacturer) by performing the following test:
 - a. Check valve piping to determine that it is properly installed and supported.
 - b. Check boiler operating temperature and pressure.
 - c. Lift the try lever on the safety relief valve to the full open position and hold it for at least five seconds or until clean water is discharged.
 - d. Release the try lever and allow the valve to close. If the valve leaks, operate the lever two or three times to clear the valve seat of foreign matter. It may take some time to determine if the valve has shut completely.
 - e. If the valve continues to leak, it must be replaced before the boiler is returned to operation.
 - f. Check that operating pressure and temperature have returned to normal.
 - g. Check again to confirm that valve has closed completely and is not leaking.
3. Test low-water cut-off (if used) as described by the manufacturer.
4. Test limit as described in Section 8E, "Check-Out Procedure."
5. Test function of gas safety shut-off features as described by gas valve and ignition control manufacturer.
6. Cycle the boiler at least once and check operation of the vent damper.

E. ANNUALLY (BEFORE START OF HEATING SEASON)

⚠ DANGER

When servicing or replacing components, be absolutely certain that the following conditions are met:

- **Water, gas and electricity are off.**
- **The boiler is at room temperature.**
- **There is no pressure in the boiler.**

1. Check flueways and burners for cleanliness and clean if necessary. Use the following procedure if cleaning is required:
 - a. Refer to the Operating Instructions in Figures 8.3 & 8.4 to properly turn off the gas to the boiler.
 - b. Turn off all electrical power to the boiler.
 - c. Remove burners and brush gas outlet ports lightly using a soft bristle brush.
 - d. Remove the vent pipe, automatic vent damper (if used), draft hood, top jacket panels, flue collector and flue baffles.
 - e. Brush flueways with wire brush.
 - f. To the extent possible, inspect inside of vent pipe and vent damper for obstructions in flow or vent damper movement. Remove or replace as necessary.
 - g. Re-install baffles. When replacing the flue collector, be certain that the blanket seal between the flue collector and top section makes a tight seal to prevent leakage of the products of combustion.

- h. Re-install the top of the jacket, draft hood, vent damper (if used) and vent pipe.
- i. Connect blocked vent switch wiring harness to blocked vent switch.
- k. Re-install burners.

2. Inspect entire venting system for corrosion, support and joint integrity. Repair as necessary.
3. Check the pilot and main burner flame. See Figure 10.1. The pilot should provide a steady flame enveloping 3/8" to 1/2" (10 mm to 13 mm) of the flame sensor. If required, adjust the pilot as stated in the gas valve manufacturer's instructions. The main burner flame inner cone should be approximately 1-1/2" (40 mm) high and should have a very sharp, blue color characteristic.
4. Systems with antifreeze. Check for correct concentration and inhibitor level.

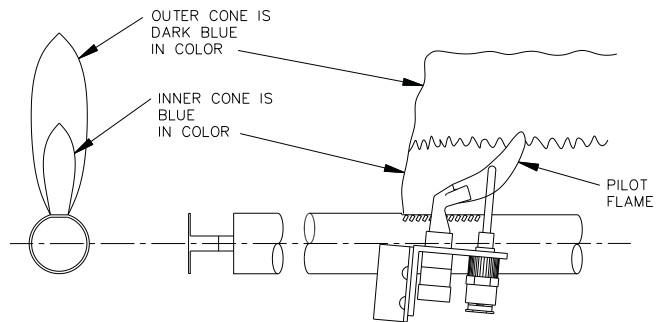

Figure 10.1: Pilot and Main Burner Flame

11. BOILER DIMENSIONS & RATINGS

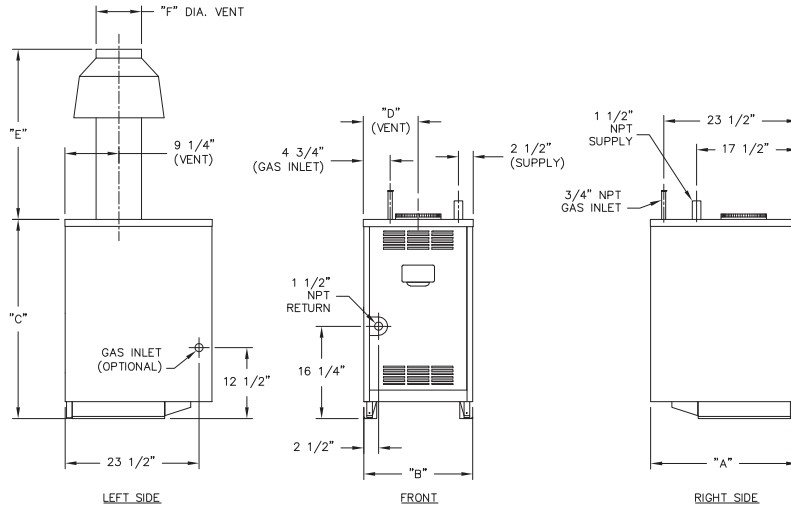

Figure 11.1: Boiler Views

Table 11.1: Series GM™ Boiler Dimensions

SERIES GM™ BOILER DIMENSIONS						
Boiler Model Number	Jacket Depth "A"	Jacket Width "B"	Jacket Height "C"	Left of Jacket to C/L of Vent "D"	Top of Jacket to Vent Connector "E"	Vent Size "F" Dia.
GM-05	25-3/4"	19-1/4"	35-1/4"	9-3/4"	29"	8"
GM-06	25-3/4"	22-3/4"	35-1/4"	11-1/2"	30"	9"
GM-07	25-3/4"	26-1/4"	35-1/4"	13-1/4"	31"	10"
GM-08	25-3/4"	29-3/4"	35-1/4"	15"	31"	10"

Table 11.2: Series GM™ Crate Dimensions & Shipping Weights

SERIES GM™ CRATE DIMENSIONS & SHIPPING WEIGHTS								
Boiler Model Number	Width		Depth		Height		Approximate Shipping Weight	
	(inch)	(mm)	(inch)	(mm)	(inch)	(mm)	(lb)	(kg)
GM-05	28	711	30-1/4	768	40-1/2	1029	433	196
GM-06	28	711	30-1/4	768	40-1/2	1029	500	227
GM-07	35	889	30-1/4	768	40-1/2	1029	574	260
GM-08	35	889	30-1/4	768	40-1/2	1029	641	291

Table 11.2: Series GM™ Boiler Ratings

SERIES GM™							AHRI CERTIFIED® www.ahridirectory.org		
Boiler Model Number	Input, MBH	Output ^{1,2} , MBH	Net Ratings Water ³ , MBH	Intermittent Ignition AFUE ¹ , %	Thermal Efficiency ² , %	Combustion Efficiency ² , %	Input, kW	Output, kW	Net Ratings Water, kW
GM-05	228	187	163	82.1	–	–	66.8	54.8	47.8
GM-06	285	238	207	82.8	–	–	83.5	69.8	60.7
GM-07	342	275	239	–	80.3	82.5	100.2	80.6	70.0
GM-08	399	320	278	–	80.3	82.5	116.9	93.8	81.5

1 Output is Heating Capacity for models with inputs <300 MBH and Gross Output for models with inputs ≥300 MBH. Heating Capacity and Annual Fuel Utilization Efficiency (AFUE) ratings are based on U.S. Government test.

2 Gross Output Rating, Thermal Efficiency and Combustion Efficiency determined in accordance with AHRI requirements.

3 Net water ratings based on an allowance of 1.15.

4 Consult factory before selecting a boiler for installations having unusual piping and pickup requirements, such as intermittent system operation, extensive piping systems, etc.

12. REPAIR PARTS

Repair parts are available from your local PB Heat, LLC distributor or from Parts To Your Door at 1 (610) 916-5380 (www.partstoyourdoor.com).

Note: Remember to include the boiler model number and serial number when ordering parts.

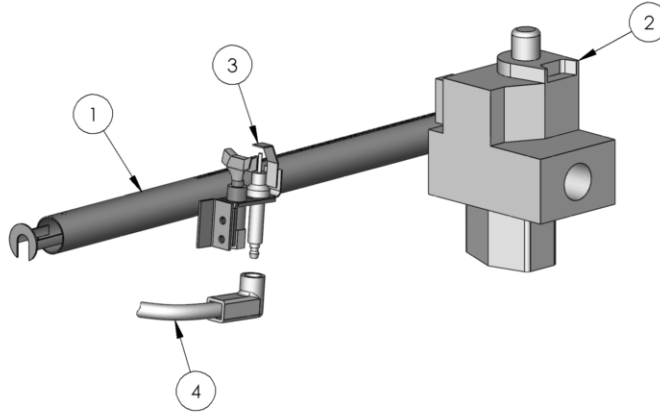

Figure 12.1: Gas Valve and Pilot

Table 12.1: Intermittent Ignition

	Description	Quantity Required	Stock Code
1	Main Burner w/ Pilot Bracket	–	50163
2	Gas Valve, Hon VR8304M, Natural Gas	–	50589
	Gas Valve, Hon VR8304P, LP Gas	–	50724
3	Pilot, Nat Gas, Q348A1002	–	50558
	Pilot, LP Gas, Q348A1358	–	51814
4	Ignition Cable	–	50627

Part numbers may be subject to change without notice.

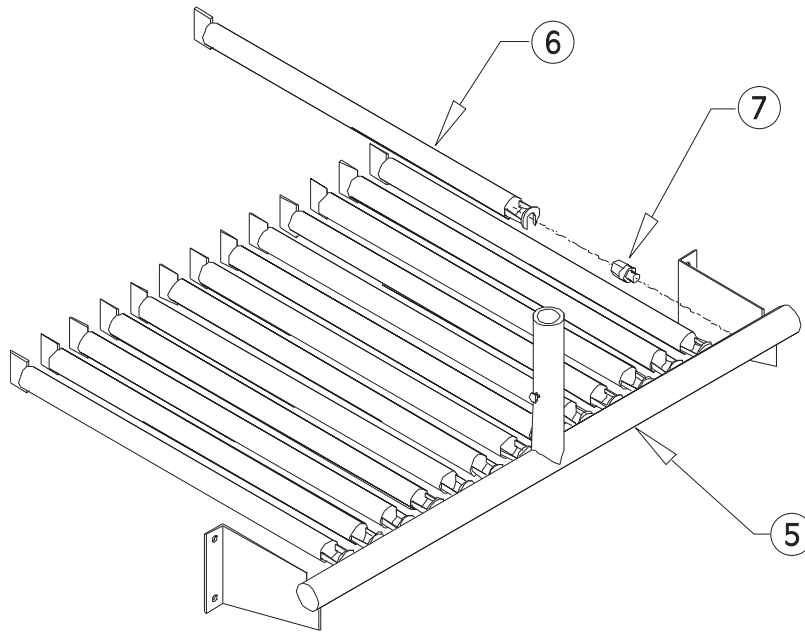

Figure 12.2

Table 12.2

	Description	Quantity Required	Stock Code
5	Gas Manifold – GM-05	–	50712
	Gas Manifold – GM-06	–	50713
	Gas Manifold – GM-07	–	50714
	Gas Manifold – GM-08	–	50715
6	Main Burner – GM-05	7	50192
	Main Burner – GM-06	9	50192
	Main Burner – GM-07	11	50192
	Main Burner – GM-08	13	50192
–	Main Burner w/ Pilot Clip	1	51540
7	Orifice Spud, #40 – Natural Gas – GM-05	8	7157
	Orifice Spud, #40 – Natural Gas – GM-06	10	7157
	Orifice Spud, #40 – Natural Gas – GM-07	12	7157
	Orifice Spud, #40 – Natural Gas – GM-08	14	7157
	Orifice Spud, #40 – LP Gas – GM-05	8	50774
	Orifice Spud, #40 – LP Gas – GM-06	10	50774
	Orifice Spud, #40 – LP Gas – GM-07	12	50774
	Orifice Spud, #40 – LP Gas – GM-08	14	50774

Part numbers may be subject to change without notice.

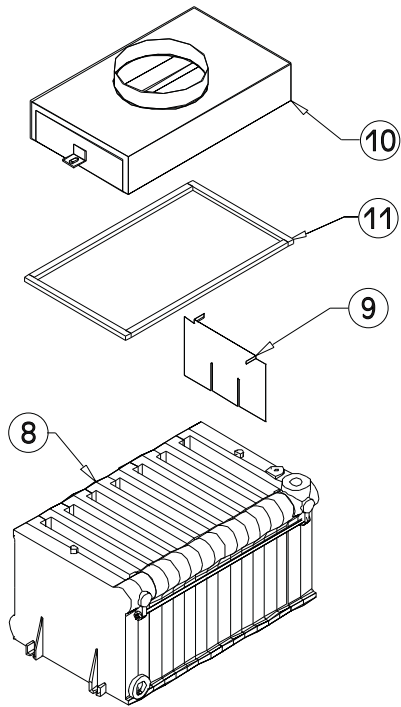

Figure 12.3a

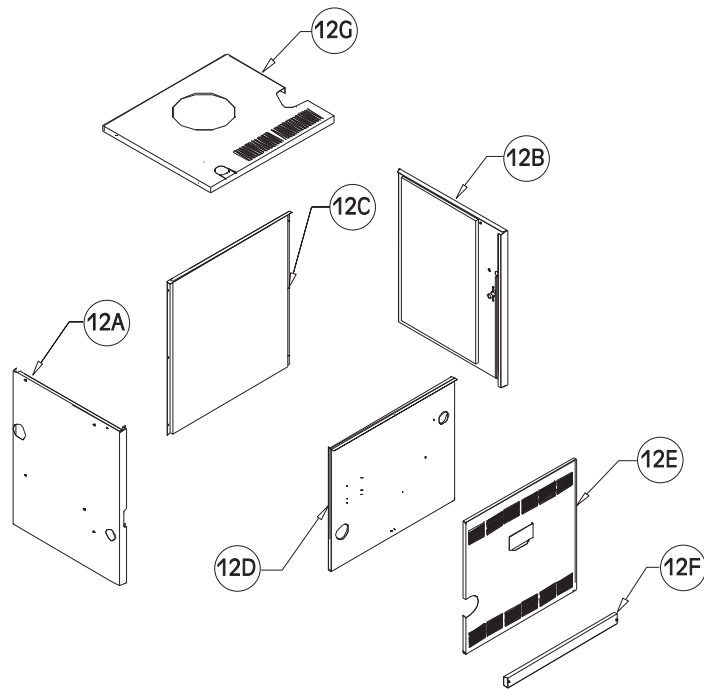

Figure 12.3b

Table 12.3

	Description	Quantity Required	Stock Code
8	Block – GM-05	–	91041
	Block – GM-06	–	91042
	Block – GM-07	–	91043
	Block – GM-08	–	91044
9	Flue Baffle (all sizes)	–	51694
10	Flue Collector, GM-05 (requires 5' of Blanket Strips Item #11)	–	90975
	Flue Collector, GM-06 (requires 6' of Blanket Strips Item #11)	–	90976
	Flue Collector, GM-07 (requires 6' of Blanket Strips Item #11)	–	90987
	Flue Collector, GM-08 (requires 7' of Blanket Strips Item #11)	–	90988
11	Flue Collector Blanket Seal (specify length)	–	50866
12	Jacket Assembly (Complete Jacket*) – GM-05	–	90465
	Jacket Assembly (Complete Jacket*) – GM-06	–	90466
	Jacket Assembly (Complete Jacket*) – GM-07	–	90467
	Jacket Assembly (Complete Jacket*) – GM-08	–	90468
	*Complete Jacket Consists of:		
12A	Left Side Panel		
12B	Right Side Panel		
12C	Rear Panel		
12D	Inner Front Panel		
12E	Removable Front Panel		
12F	Lower Front Panel		
12G	Top Panel		

Part numbers may be subject to change without notice.

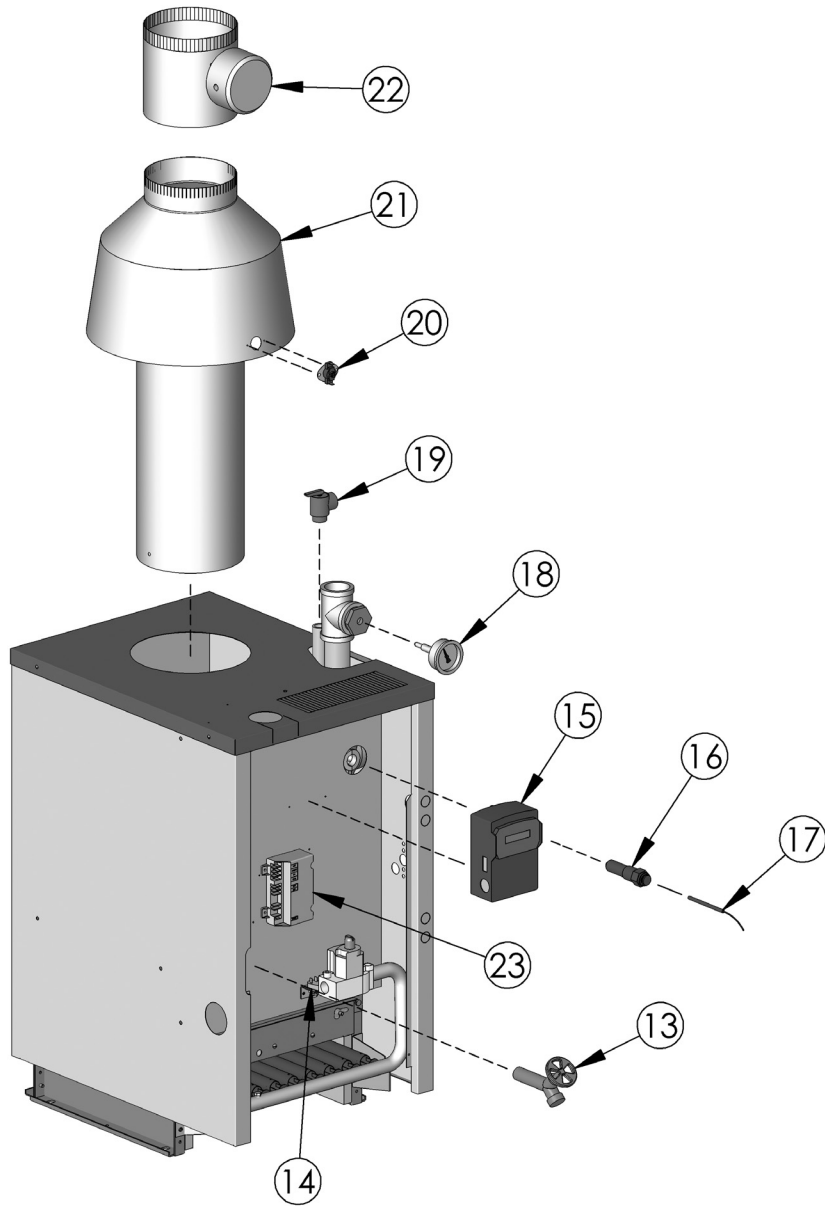

Figure 12.4

Table 12.4

	Description	Quantity Required	Stock Code
13	3/4" Drain Valve, Conbraco 31-602-04	–	50517
14	Flame Rollout Safety Shutoff Switch	–	51587
15	Limit Control, Beckett AquaSmart 7600B	–	50335
	Limit Control, Hydrolevel HydroStat 3200, with sensor	–	50334
16	Immersion Well, Beckett 7600T	–	50341
	Immersion Well, Hydrolevel	–	50723
17	Immersion Sensor, Beckett 7600P	–	50339
	Immersion Sensor, Hydrolevel	–	54522
18	Temperature-Pressure Gage [30, 50 PSI (207 kPa, 345 kPa) safety relief valve]	–	51774
	Temperature-Pressure Gage [80, 100 PSI (552 kPa, 689 kPa) safety relief valve]	–	55845
19	Safety Relief Valve, 30 PSI (207 kPa)	–	50501
	Safety Relief Valve, 50 PSI (345 kPa)	–	99950
	Safety Relief Valve, 80 PSI (552 kPa)	–	99502
	Safety Relief Valve, 100 PSI (689 kPa)	–	50118
20	Blocked Vent Switch (Vent Safety Shutoff)	–	51590
21	Draft Hood, GM-05 (8" outlet)	–	90995
	Draft Hood, GM-06 (9" outlet)	–	90996
	Draft Hood, GM-07, GM-08 (10" outlet)	–	90997
22	Automatic Vent Damper, GM-05 (8" outlet)	–	90611
	Automatic Vent Damper, GM-06 (9" outlet)	–	50167
	Automatic Vent Damper, GM-07, GM-08 (10" outlet)	–	50168
23	Ignition Module, Honeywell S8610M	–	50672
–	Burner Access Panel – GM-05	–	91266
–	Burner Access Panel – GM-06	–	91267
–	Burner Access Panel – GM-07	–	91268
–	Burner Access Panel – GM-08	–	91269

Part numbers may be subject to change without notice.

Series GM™

Gas Boilers

Installation, Operation & Maintenance Manual

TO THE INSTALLER:

This manual is the property of the owner and must be affixed near the boiler for future reference.

TO THE OWNER:

This boiler should be inspected annually by a Qualified Service Agency.



**AUDI
ATRI
MEMBER**



PeerlessBoilers.com

PB HEAT, LLC

131 S. CHURCH STREET • BALLY, PA 19503