

## SPECIFICATIONS

### Configurations

- Upflow / Horizontal

### Heat Exchanger Design

- Aluminized steel primary heat exchanger with crimped non-welded construction
- AL29-4C stainless steel secondary heat exchanger

### Burners

- Aluminized steel in shot burners for smooth ignition
- Isolated burner enclosure for quiet operation

### Cabinet Design

- Compact 33" height
- Standardized widths for easy coil fit
- Unitized construction for cabinet integrity
- Heat exchanger compartment is insulated to increase efficiency and reduce sound levels
- Baked on pre painted steel cabinet finish

### Air Delivery System

- Efficient ECM variable speed blower motor
- Motor features "soft start" and "soft stop" for quiet operation
- Active and passive dehumidification feature
- Easily removable slide-out blower design
- Dynamically balanced blower wheel with resilient motor mounts for smooth and quiet operation

### Controls

- Two stage gas valve
- Integrated ignition and fan control
- Control board retains last five (5) fault codes with push button memory recall, regardless of power interruption
- Hot surface ignition system uses silicon nitride ignitor
- Control features 120 volt electronic air cleaner and humidifier terminals
- Control circuit is fuse protected
- Color coded control wiring
- Compatible with single or two stage thermostats for heating.
- Two stage thermostat is recommended when installed with two stage cooling unit.

### Venting

- 2-speed induced draft motor with stainless steel shaft, steel ball bearings, and fan cooled for long life
- Vent materials for Canadian application must comply with ULC S636
- Certified for direct vent (2-pipe) or non-direct (1-pipe) applications
- Direct vent refers to a combustion air supply intake pipe installed in conjunction with flue gas vent pipe

### Installation Features

- Left or right gas and electric entry
- Zero step horizontal conversion
- Removable floor base for bottom return air

## TWO STAGE VARIABLE SPEED GAS FURNACE

97%



### California Only

*This furnace does not meet the South Coast Air Quality Management District (SCAQMD) Rule 1111 and San Joaquin Valley Air Pollution Control District (SJVAPCD) Rule 4905 NOx emission limit (14 ng/J) and cannot be installed within the SCAQMD or SJVAPCD and Bay Area.*

**Warranty**—20 years on heat exchanger, 6 years on parts  
(Some limitations apply; see printed warranty for details.)

[www.century-hvac.com](http://www.century-hvac.com)

# MODEL NUMBER GUIDE

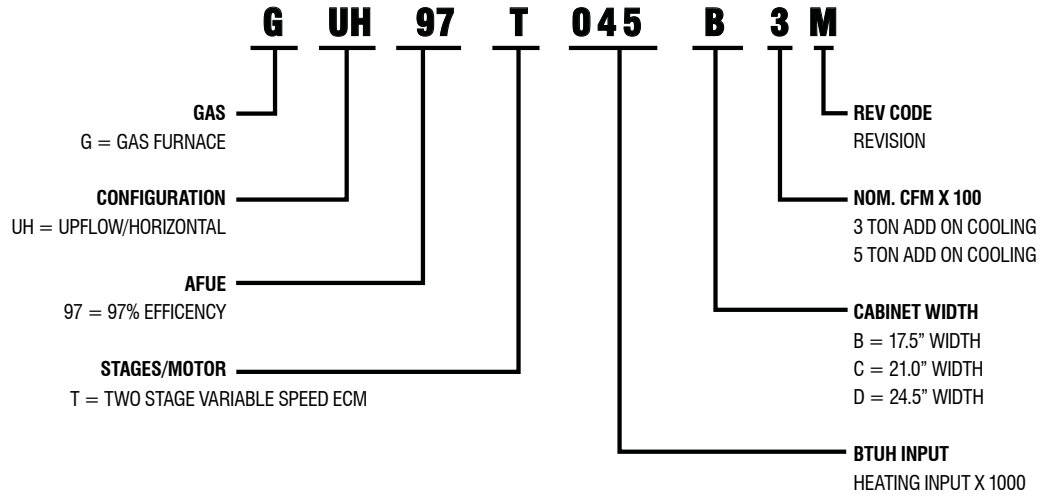

## FILTER REQUIREMENT DATA

Tonnage	Disposable Filters	Cleanable Filters
	Minimum Area (sq. in.)	Minimum Area (sq. in.)
3	576	288
5	960	480

NOTES: Areas shown for permanent filters are based on filters rated at 600 feet per minute face velocity.

## DIMENSIONS (IN.)

Model	A	B	C	D
GUH97T045B3M	17-1/2	16-3/8	16	7-5/8
GUH97T070B3M	17-1/2	16-3/8	16	7-5/8
GUH97T090C3M	21	19-7/8	19-1/2	9-3/8
GUH97T090C5M	21	19-7/8	19-1/2	9-3/8
GUH97T110C5M	21	19-7/8	19-1/2	9-3/8
GUH97T135D5M	24-1/2	23-3/8	23	11-1/8

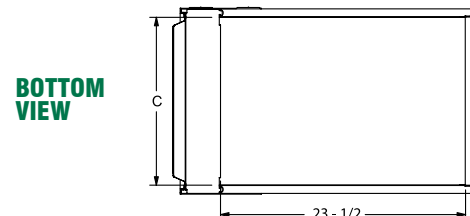
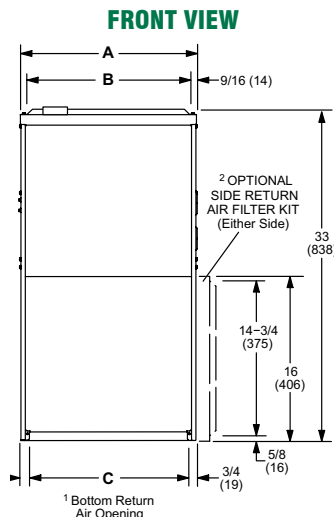
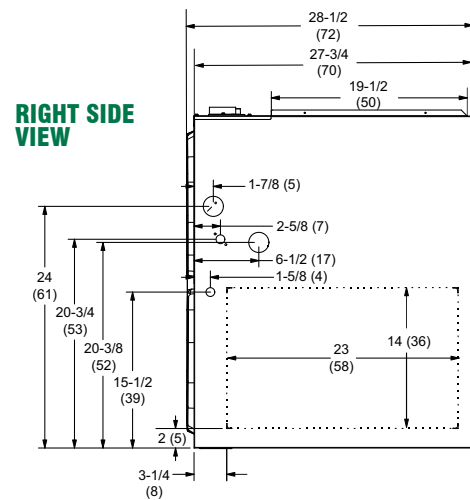
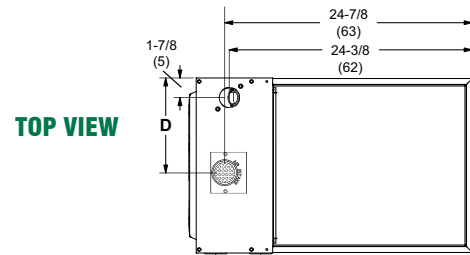

## BLOWER PERFORMANCE DATA

Model	Motor Size (hp)	Blower Size	Heating Temp Rise (F°)	Heating CFM @ .10" - .80" w.c.				Cooling Stage	Cooling CFM @ .10" - .80" w.c.				Speed Adjust
				Setting "D"	Setting "C"	Setting "B"	Setting "A"		Setting "D"	Setting "C"	Setting "B"	Setting "A"	
GUH97T045B3M	1/2	10 x 9	35-65 High Fire	745	875	990	1005	2nd Stage	905	1075	1210	1370	+
				685	765	895	910		815	980	1120	1255	Norm
				610	695	785	810		720	885	1020	1135	-
			20-50 Low Fire	685	765	895	910	1st Stage	595	760	865	980	+
				620	705	800	820		540	660	785	890	Norm
				545	625	715	725		485	600	695	790	-
GUH97T070B3M	1/2	10 x 9	50-80 High Fire	965	1060	1130	1255	2nd Stage	860	1060	1215	1365	+
				880	960	990	1140		810	960	1130	1265	Norm
				810	840	890	1030		705	840	1005	1140	-
			25-55 Low Fire	940	990	1070	1195	1st Stage	600	740	840	970	+
				830	895	965	1100		555	665	770	855	Norm
				755	825	840	975		500	600	680	790	-
GUH97T090C3M	1/2	10 x 9	60-90 High Fire	1060	1135	1240	1315	2nd Stage	875	1040	1210	1360	+
				960	1040	1120	1199		800	945	1100	1245	Norm
				830	935	980	1084		720	840	970	1115	-
			30-60 Low Fire	960	1040	1120	1206	1st Stage	625	710	830	950	+
				875	945	995	1100		565	670	760	860	Norm
				790	840	920	950		520	610	685	785	-
GUH97T090C5M	1	11 x 11	40-70 High Fire	1450	1565	1725	1865	2nd Stage	1385	1595	1820	2020	+
				1310	1450	1585	1690		1225	1465	1645	1885	Norm
				1155	1305	1450	1545		1065	1320	1504	1675	-
			25-55 Low Fire	1120	1265	1420	1520	1st Stage	935	1055	1275	1465	+
				965	1120	1285	1395		835	980	1120	1335	Norm
				865	950	1120	1235		740	870	1010	1150	-
GUH97T110C5M	1	11 x 11	45-75 High Fire	1560	1760	1905	1955	2nd Stage	1310	1560	1745	1955	+
				1415	1610	1740	1795		1220	1405	1570	1795	Norm
				1285	1485	1560	1635		1075	1270	1430	1635	-
			35-65 Low Fire	1155	1325	1420	1500	1st Stage	935	1065	1245	1405	+
				1055	1200	1310	1360		865	970	1145	1280	Norm
				935	1075	1170	1245		790	890	1025	1165	-
GUH97T135D5M	1	11 x 11	45-75 High Fire	1650	1845	2000	2055	2nd Stage	1395	1640	1840	2055	+
				1495	1660	1880	1905		1290	1480	1660	1905	Norm
				1360	1500	1670	1705		1170	1330	1500	1705	-
			35-65 Low Fire	1300	1435	1630	1652	1st Stage	1015	1160	1330	1480	+
				940	1085	1200	1345		940	1085	1200	1345	Norm
				1095	1190	1340	1343		870	965	1110	1225	-

## PHYSICAL AND ELECTRICAL DATA

Model	1st Stage		2nd Stage		AFUE (ICS)	Nominal* Cooling Capacity (tons)	Gas Inlet (in.)	Volts/ Hertz/ Phase	Min. Time Delay Breaker or Fuse	Nominal F.L.A.	Trans. (V.A.)	Approx. Shipping Weight (lbs.)
	Input (Btuh)	Output * (Btuh)	Input (Btuh)	Output * (Btuh)								
GUH97T045B3M	29,000	28,000	44,000	43,000	97.0	3	1/2	120-60-1	15	7.7	40	120
GUH97T070B3M	43,000	42,000	66,000	64,000	97.0	3	1/2	120-60-1	15	7.7	40	124
GUH97T090C3M	57,000	56,000	88,000	85,000	97.0	3	1/2	120-60-1	15	7.7	40	144
GUH97T090C5M	57,000	56,000	88,000	86,000	97.0	5	1/2	120-60-1	20	12.8	40	153
GUH97T110C5M	72,000	70,000	110,000	107,000	97.0	5	1/2	120-60-1	15	12.8	40	159
GUH97T135D5M	86,000	84,000	132,000	127,000	97.0	5	1/2	120-60-1	20	12.8	40	178

Note: For vent length and clearances to combustibles, please reference installation instructions.

\* At full capacity

## ACCESSORY LIST

CATALOG NUMBER	DESCRIPTION
<b>External Filter Rack Kits</b>	
1.841018	1 pack (16 x 25)
1.841039	10 pack (16 x 25)
<b>Natural to LP Kits</b>	
11K48	2-Stage - 90%
11K47	High Altitude 2-Stage (>4500ft.)
<b>Return Air Base</b>	
68W62	17.5" B Width
68W63	21.0" C Width
68W64	24.5" D Width
<b>Night Service Kits</b>	
89W50	Two Stage
<b>Horizontal Suspension Kit</b>	
51W10	90% Kit
<b>Flush Mount Termination (90% Furnaces only) US Only</b>	
51W11	2" & 3" Vent Version
<b>Concentric Vent Kit (90% Furnaces only) US Only</b>	
71M80	1-1/2" Vent Version
69M29	2" Vent Version
60L46	3" Vent Version
<b>Concentric Vent Kit (90% Furnaces only) Canada</b>	
44W92	1-1/2" and 2" Vent Version
44W93	3" Vent Version

For vent length and clearances to combustibles, please reference installation instructions.

"This product complies with all California product labeling laws including, but not limited to, the Safe Drinking Water and Toxic Enforcement Act of 1986, more commonly known as Proposition 65."

*Due to ongoing product improvements, specifications and dimensions are subject to change and correction without notice or incurring obligations. Determining the application and suitability for use of any product is the responsibility of the installer. Additionally, the installer is responsible for verifying dimensional data on the actual product prior to beginning any installation preparations. Third party incentive and rebate programs have precise requirements as to product performance and certification. All products meet applicable regulations in effect on date of manufacture; however, certifications are not necessarily granted for the life of a product. Therefore, it is the responsibility of the applicant to determine whether a specific model qualifies for these incentive/rebate programs.*