



Better Boilers

SL 26-260 G3, SL 40-399 G3
MODULATING GAS BOILERS
(Natural Gas or Propane)



WARNING: If the information in this manual is not followed exactly, a fire or explosion may result causing property damage, personal injury, or loss of life.

Do not store or use gasoline or other flammable vapors and liquids or other combustible materials in the vicinity of this or any other appliance.

WHAT TO DO IF YOU SMELL GAS:

- Do not try to light any appliance.
- Do not touch any electrical switch; do not use any phone in your building.
- Immediately call your gas supplier from a nearby phone. Follow the gas supplier's instructions.
- If you cannot reach your gas supplier, call the fire department.

Installation and service must be performed by a qualified installer, service agency or the gas supplier.

This Manual is also available in French - contact IBC or visit our web site www.ibcboiler.com

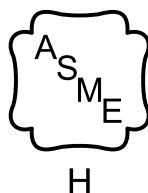

⚠ WARNING

If the information in this manual is not followed exactly, a fire or explosion may result causing property damage, personal injury, or loss of life.

SAFETY CONSIDERATIONS

Installation, start-up and servicing of IBC boilers must be performed by competent, qualified, licensed and trained heating technicians.

Failure to read and comply with all instructions and applicable National and local codes may result in hazardous conditions that could result in property damage and injury to occupants which in extreme cases might result in death.

HAZARDS & PRECAUTIONS**⚠ DANGER**

Points out an immediately hazardous situation which must be avoided in order to prevent serious injury or death.

⚠ WARNING

Points out a potentially hazardous situation which must be avoided to prevent serious injury or death.

⚠ CAUTION

Points out a potentially hazardous situation which must be avoided to prevent possible moderate injury and/or property damage

⚠ NOTE

Points out installation, maintenance and operation details that will result in enhanced efficiency, longevity and proper operation of your boiler.

Supplied with the boiler - The IBC boiler is shipped with an accessory parts kit consisting of the following items:

- 1 x Wall mounting bracket 260 G3 (22") 250-244
- 1 x Wall mounting bracket 399 G3 (24") 250-726
- 1 x Condensate trap assembly
- 1 x 30 psig pressure relief valve
- 1 x Outdoor temperature sensor
- 6 x 1/4" x 2 1/2" Lag screws/w flat washers
- Installation and Operating Instructions Manual
- User Manual
- V10 Touchscreen Operating Instructions Manual

SPECIFICATIONS

SPECIFICATION	SL 26-260 G3	SL 40-399 G3
CSA Input (Natural Gas or Propane) - MBH	26 - 260	40 - 399
CSA Input (Natural Gas or Propane) - kW	7.62 - 76.2	11.7 - 117
CSA Output - MBH	24.9 - 239	38.4 - 383
CSA Output - kW	7.31 - 70.0	11.2 - 112
A.F.U.E	95%	
Combustion Efficiency BTS-2000 Thermal Efficiency		96% 96%
Minimum gas supply pressure (Natural Gas or Propane) - inch w.c.	4	4
Maximum gas supply pressure (Natural Gas or Propane) - inch w.c.	14	14
Ambient temperature - Low °F / °C High °F / °C	32°F / 0°C 122°F / 50°C	32°F / 0°C 122°F / 50°C
Max. relative humidity (non-condensing)	90%	90%
Minimum water temp.	34°F / 1°C	34°F / 1°C
Maximum water temp. (electronic hi-limit)	190°F/ 88°C	190°F/ 88°C
Max. ΔT - supply/return (electronic fence)	40°F	40°F
Max. Water Temperature Lockout Limit	201°F/ 94°C	201°F/ 94°C
Power use (120Vac/60Hz) @ full fire - Watts	127 (less pumps)	190 (less pumps)
Weight (empty) - lbs/Kg	162 / 74	240 / 110
Heating Surface Area - ft ² / m ²	22.71 / 2.11	36.56 / 3.40
Pressure vessel water content - USG/Litres	4.64 / 17.6	6.66 / 25.2
Maximum boiler flow rate - USgpm	25	45
Minimum boiler flow rate - USgpm	6	20
Maximum operating water pressure* - psig	30	80
Minimum water pressure - psig	8	8
Approved installation altitude - ASL	0 - 12,000'	0 - 12,000'
Maximum equivalent vent length Each side (Vent & Air Intake)) (Natural Gas or Propane) Air intake options: either direct vent or indoor supply	200' (3")	200' (4")

* boilers are shipped with 30 psig pressure relief valve.

THIS PAGE IS INTENTIONALLY LEFT BLANK.

Contents

1.0 INSTALLATION	1-1
1.1 GENERAL	1-1
1.2 CODE REQUIREMENTS	1-3
1.3 LOCATION	1-3
1.4 EXHAUST VENTING AND AIR INTAKE	1-5
1.4.1 Applications	1-6
1.4.2 Exhaust Vent Material	1-6
1.4.3 Vent Travel	1-7
1.4.4 Venting Passage Through Ceiling and Floor	1-9
1.4.5 Rooftop Vent Termination	1-9
1.4.6 Sidewall Vent Termination	1-10
1.4.7 "Direct Vent" Combustion Air Intake Piping	1-15
1.4.8 "Indoor Air" Combustion Air Intake	1-16
1.4.9 Combustion Air Filtration	1-17
1.4.10 Closet Installations	1-17
1.5 CONDENSATE REMOVAL	1-18
1.5.1 Condensate Trap	1-18
1.5.2 Condensate Trap Assembly - Installation	1-18
1.5.3 Condensate Trap Assembly - cleaning procedure	1-19
1.5.4 Further installation details	1-19
1.6 WATER PIPING	1-21
1.6.1 General Piping Issues	1-21
1.6.2 Installation Rules	1-24
1.7 GAS PIPING	1-28
1.8 ELECTRICAL CONNECTIONS	1-29
1.8.1 120 VAC Line Voltage Hook-up	1-29
1.8.2 Power Quality and Electrical Protection	1-30
1.8.3 Zone Valve Hook-up	1-30
1.8.4 Thermostat / Sensor Wiring	1-30
1.8.6 Thermostat Heat Anticipator	1-31
2.0 IBC BOILER CONTROLLER	2-1
2.1 GENERAL	2-1
2.2 CONTROL	2-1
2.3 CONTROL INTERFACE	2-2
3.0 STARTUP & COMMISSIONING	3-1
3.1 BOILER SHUTDOWN & LIGHTING	3-1
3.2 PRIOR TO START-UP	3-2
3.2.1 Pre-Ignition Checks	3-2
3.2.2 Test Ignition Safety Shutoff	3-2
3.3 COMMISSIONING	3-2
3.3.1 Gas Valve and Fan Diagrams	3-4
3.4 FUEL CONVERSION	3-5
3.4.1 Gaining access to combustion chamber and burner removal instructions	3-6
4.0 MAINTENANCE	4-1

4.1 BOILER MAINTENANCE	4-1
4.1.1 General Care	4-1
4.1.2 Inspection	4-1
4.1.3 Venting	4-1
4.1.4 Condensate Traps	4-1
4.1.5 Burner	4-1
4.1.6 Heat Exchanger	4-1
4.1.7 Pump	4-2
4.1.8 Gas Piping	4-2
4.1.9 Touchscreen Boiler Controller	4-2
4.1.10 Water	4-2
4.1.11 Freeze Protection	4-2
4.1.12 Boiler Treatment	4-2
4.1.13 Relief Valve - Maintenance and Testing	4-3
4.2 GEOGRAPHY & COMPONENTS	4-4
4.2.1 Fan and gas valve removal instructions	4-6
4.2.2 Fan and gas valve re-installation	4-7
4.2.3 Replacing the gas valve	4-8
5.0 TROUBLESHOOTING	5-1
5.1 PRELIMINARY CHECKS	5-1
5.2 ELECTRONIC COMPONENTS	5-2
5.2.1 Temperature Sensors	5-2
5.2.2 Fan	5-3
5.2.3 Water Pressure Sensor	5-3
5.2.4 Safety and Ignition Module (SIM)	5-3
5.2.4.1 Low water cutoff function: reset and test	5-4
5.2.4.2 Water Temperature function: reset and test	5-5
5.3 TROUBLESHOOTING	5-6
5.3.1 Using Control Module Errors Displayed	5-6
5.3.2 Ignition Problems	5-8
5.3.3 Cycling Problems	5-9
5.3.4 Temperature Problems	5-10
5.3.5 Miscellaneous	5-11
6.0 DIAGRAMS	6-1
6.1 PARTS DIAGRAMS	6-2
6.2 WIRING DIAGRAMS	6-7
6.3 SEQUENCE OF OPERATION	6-9
INSTALLATION & COMMISSIONING REPORT	6-10
INSTALLER SET-UP	6-11
SERVICE RECORD	6-12
NOTES	6-13
REVISION HISTORY	6-15

⚠ DANGER

Should overheating occur or the gas supply fails to shut off, do not turn off or disconnect the electrical supply to the pump. Instead shut off the gas supply at a location external to the appliance

⚠ WARNING

Do not use this boiler if any part has been under water. Immediately call a qualified service technician to inspect the boiler and to replace any part of the control system and any gas control that has been under water.

⚠ CAUTION

Care must be taken to properly size the boiler for its intended use. Prolonged full fire run time, over-sizing or under-sizing, and incorrect flow rates through the boiler can lead to increased maintenance costs, equipment stress and premature failure.

⚠ WARNING

If the boiler can become exposed to fluid temperatures below 34°F (1°C), a method of protection to prevent freezing of condensate should be employed. Contact the factory for further information.

The Installer must carefully read this manual to ensure that all installation details can be adhered to. Special attention is to be paid to clearances and access, vent travel and termination, gas supply, condensate removal and combustion air supply.

The Installer should do a pre-installation check to ensure that the following precautions can be observed:

- The boiler should be installed in areas where the combustion air source is not subject to chemical fouling or agricultural vapors. Exposure to corrosive chemical fumes such as chlorinated and/or fluorinated hydrocarbons can reduce the life of a boiler. Cleaners, bleaches, air fresheners, refrigerants, aerosol propellants, dry-cleaning fluids, de-greasers and paint-removers all contain vapors which can form corrosive acid compounds when burned in a gas flame. Airborne chlorides such as those released with the use of laundry detergents are also to be avoided.
- The boiler should be located where water leakage will not result in damage to the area. If a location such as this cannot be found, a suitable drain pan should be installed under the appliance. The boiler is not to be installed above carpeting.
- At a new construction site, or during renovations, action must be taken to protect the boiler from drywall dust or other construction related contaminants; combustion air should be drawn from a CLEAN source (e.g. outdoors) and the boiler should be isolated from interior dust sources. Do not seal boiler case openings directly when firing - allow for air circulation and ventilation in the immediate area.
- When the boiler is in operation, the impact of the steam plume normally experienced at the exhaust terminal of a condensing boiler should be assessed. Generally, intake and exhaust pipes should terminate at a rooftop or sterile wall location. Boiler condensate is corrosive. Protective measures must be taken to prevent corrosion damage to metal roofs or other metal building components in contact with the condensate. Keep exhaust plumes well away from all building air intakes including those of neighboring properties.
- The exhaust outlet should be placed so as to reach 12" minimum above the down-turned intake - to avoid exhaust re-ingestion.
- For sidewall venting options: Both the inlet and exhaust terminations should normally be located on the same plane (side) of the building. The elevation of both pipes can be raised in "periscope style" after passing through the wall to gain required clearance above grade and snow level.
- If the indoor combustion air option is used, ensure combustion air openings to the boiler room remain unblocked and free of obstructions.
- Examine the condensate outlet to ensure proper disposal of condensate will occur during operation. If condensates are to be discharged into building drain piping materials that are subject to corrosion, a neutralization package must be used.
- Ensure that the pressure relief valve will be installed with no valves or other means of isolation between its inlet and the boiler. Make sure the relief valve outlet will be piped with unobstructed piping (minimum 3/4" diameter) to a safe discharge location.

THIS PAGE IS INTENTIONALLY LEFT BLANK

1.0 INSTALLATION

1.1 GENERAL

The gas-fired modulating boilers are low pressure, fully condensing units having a variable input range. Approved as “Category IV” vented appliances, the boilers use either Direct Vent (sealed combustion) or indoor combustion air, providing a great degree of installation flexibility.

The following table displays the required connection specifications for each model.

DESCRIPTION		SL 26-260 G3	SL 40-399 G3
A	Exhaust Outlet	3" Schedule 40	4" Schedule 40
B	Combustion Air Inlet	3" Schedule 40	4" Schedule 40
C	Safety Relief Valve and Air Vent	3/4" NPT - F	3/4" NPT - F
D	Touchscreen display	2-1/4" x 4"	2-1/4" x 4"
E	Water Outlet	1-1/2" NPT-M	1-1/2" NPT - M
F	Water Inlet	1-1/2" NPT-M	1-1/2" NPT - M
G	Knock-outs (8)	1/2"	1/2"
H	Gas Inlet	3/4" NPT-F	3/4" NPT - F
I	Condensate Outlet	3/4" Hose	3/4" Hose

Table 1: Connections

Figures 1A and 1B show outer case dimensions, piping and electrical holes. Refer to these figures to help with finding a suitable location for the boiler. See also Section 1.3 Location.

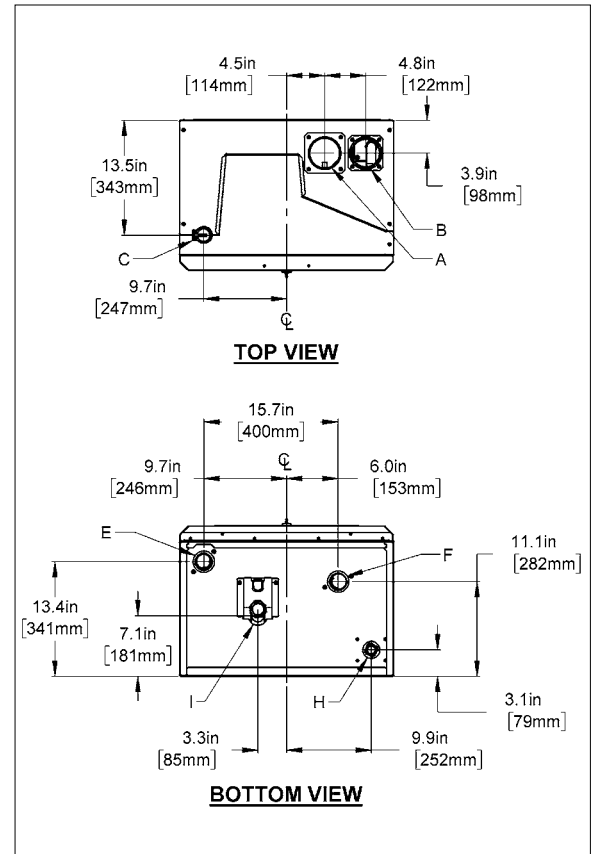
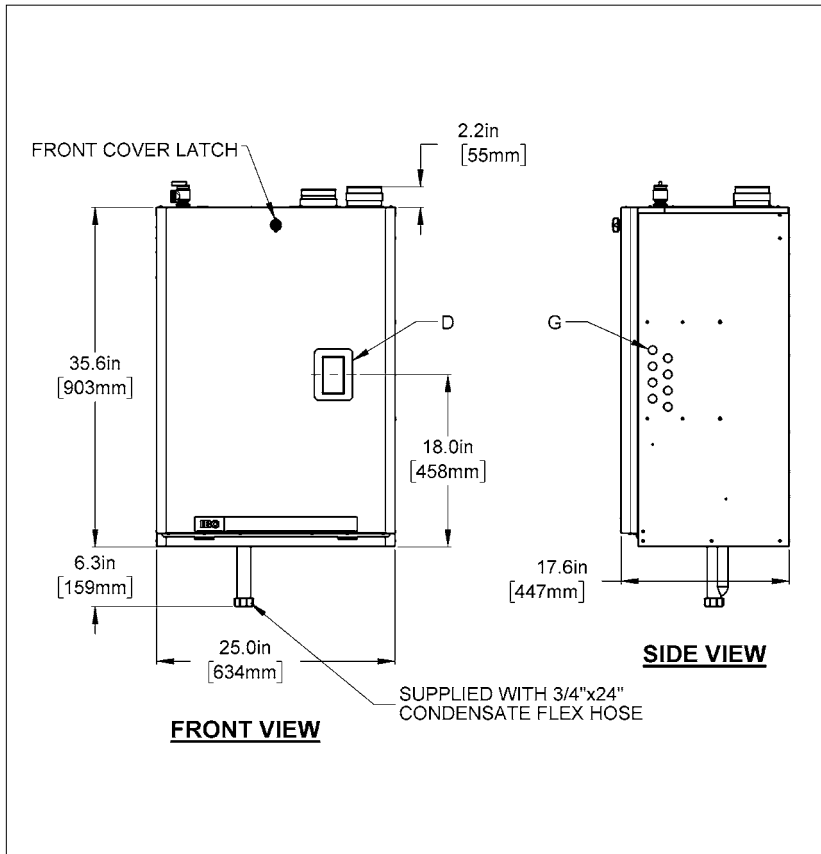

Figure 1A: Dimensions / Connections for SL 26-260 G3

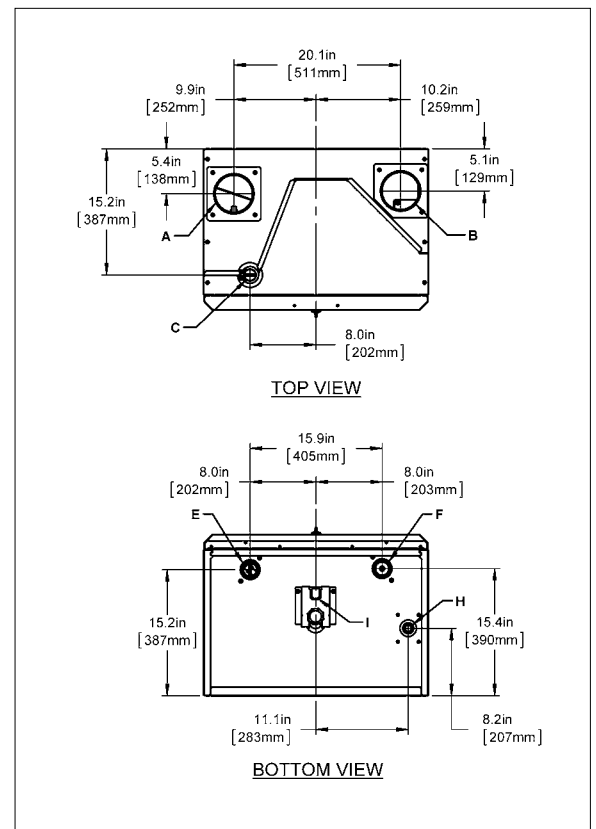
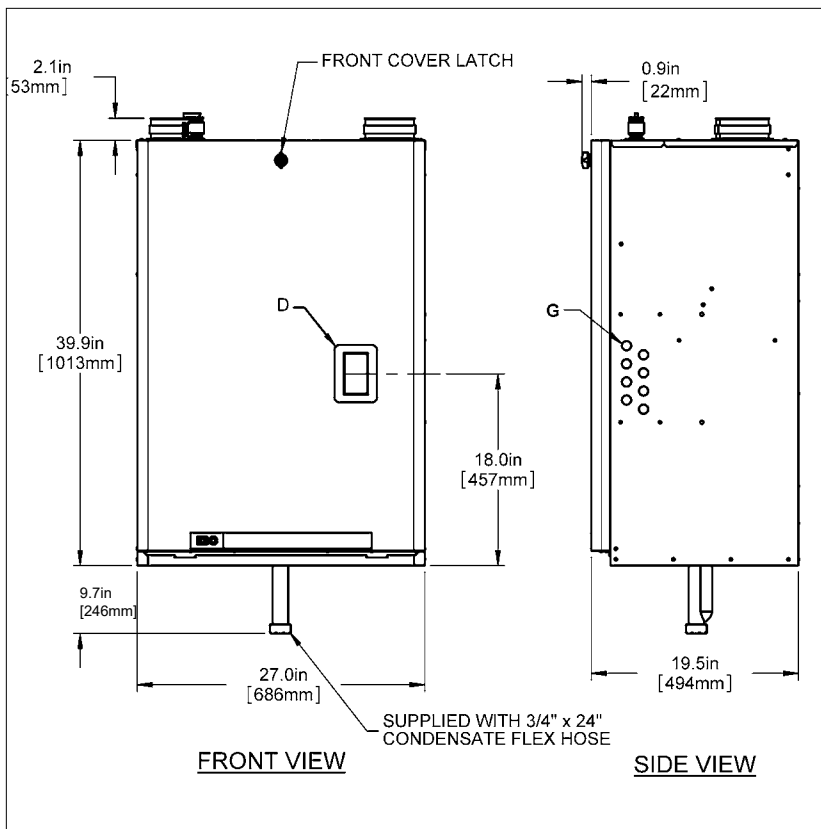

Figure 1B: Dimensions / Connections for SL 40-399 G3

1.2 CODE REQUIREMENTS

The boilers are tested and certified under CSA 4.9-2014 / ANSI Z21.13-2014.

Installation must conform to local codes, or in the absence of these, with the latest editions of CAN/CGA B149.1 and the Canadian Electrical Code Part 1 CSA C22.2 No. 1.

In the US, installations must conform to the current National Fuel Gas Code ANSI Z223.1 and the National Electrical Code ANSI/NFPA 70. Where required by jurisdiction, installation must conform to the Standard for Controls and Safety Devices for Automatically Fired Boilers, ANSI/ASME CSD-1. If there is any conflict, then the more stringent requirement will apply.

1.3 LOCATION

The boilers are designed and approved for indoor installation (wall or rack mounting), with significant flexibility of location provided with the available venting options. The boiler can be placed in an alcove, basement, closet or utility room. Surrounding conditions shall be 32°F (0°C) to 122°F (50°C) and less than 90% relative humidity.

Install the boiler in areas where the combustion air source is not subject to chemical fouling or agricultural vapors. Exposure to corrosive chemical fumes such as chlorinated and/or fluorinated hydrocarbons can reduce the life of a boiler. Cleaners, bleaches, air fresheners, refrigerants, aerosol propellants, dry-cleaning fluids, de-greasers and paint-removers all contain vapors that can form corrosive acid compounds when burned in a gas flame. Airborne chlorides such as those released with the use of laundry detergents are also to be avoided. For this reason, the indoor air venting option using air surrounding the boiler should not be used in a laundry room. Similarly, ensure any direct vent air source is not adjacent to a clothes dryer exhaust terminal. Avoid agricultural applications where the boiler and/or the intake air source are affected by ammonia and/or dust.

Locate the boiler where water leakage will not result in damage to the area. If a location such as this cannot be found, a suitable drain pan should be installed under the appliance. The boiler is not to be installed above carpeting.

Boiler weight – without water and any effect of system piping and components – is up to approx. 240 lbs/110 kg. For support fasteners, use the supplied 6 x 1/4" x 2 1/2" long lag screws. Installer to supply 1/4" bolts if metal mounting systems are used. Fasteners are to be attached to solid material capable of supporting the combined weight of the boiler and piping assembly components.

Other factors to consider for mounting sites:

- Adhere to the minimum clearance requirements for combustibile materials (see Table 2).
- A minimum 24" clearance at the front and 12" above the boiler is recommended for adequate servicing. Check local codes for additional access and service clearance requirements.

WARNING

Keep boiler area free and clear of combustibile materials, gasoline, and other flammable vapors and liquids.

WARNING

Combustion air must not be drawn from areas containing corrosive air from swimming pools or spas, including air directly next to outdoor pools and spas.

WARNING

The boiler shall not be exposed to water leaks from piping or components located overhead. This includes condensation dropping from un-insulated cold water lines overhead.

WARNING

Ensure the gas ignition system components are protected from water (dripping, spraying, rain, etc.) during appliance operation and when servicing (pump replacement, condensate trap servicing, control replacement, etc.)

⚠ WARNING

Exposed water piping and associated components (relief valves, circulators, etc.) should not be in contact with combustible materials. Check local codes for required clearances and/or provide adequate insulation.

- At a new construction site, or during renovations, action must be taken to protect the boiler from drywall dust or other construction related contaminants; combustion air should be drawn from a CLEAN source (e.g. outdoors) and the boiler should be isolated from interior dust sources. Do not seal boiler case openings directly when firing - allow for air circulation and ventilation in the immediate area.

A minimum distance below the boiler of 12" is required to provide clearance for the supplied condensation trap assembly. More clearance will typically be required to accommodate associated water and gas piping.

Clearance from Boiler Cabinet

Surface	Minimum Distance from combustible surfaces	Recommended distance for installation and service	
		SL 26-260 G3	SL 40-399 G3
FRONT	2"	24"	24"
REAR	0"	0"	0"
LEFT SIDE	1"	0" (to non-combustibles)	0" (to non-combustibles)
RIGHT SIDE	1"	4" (for electric connections)	4" (for electric connections)
TOP	2"	6" (for vent connection)	12" (for vent connection)
BOTTOM	0"	12" (for condensate trap and piping)	12" (for condensate trap and piping)

Table 2 - Clearance from boiler cabinet

⚠ WARNING

DO NOT MOUNT THIS BOILER TO HOLLOW WALL STRUCTURES - The weight of the boiler alone is 240 pounds. The combined weight of the boiler, its water contents and associated piping components can exceed 300 pounds. Fasteners must be rated for this strain, and must be firmly anchored into solid material that will support this weight.

Installers are to take all necessary precautions to avoid injury during the installation of this boiler.

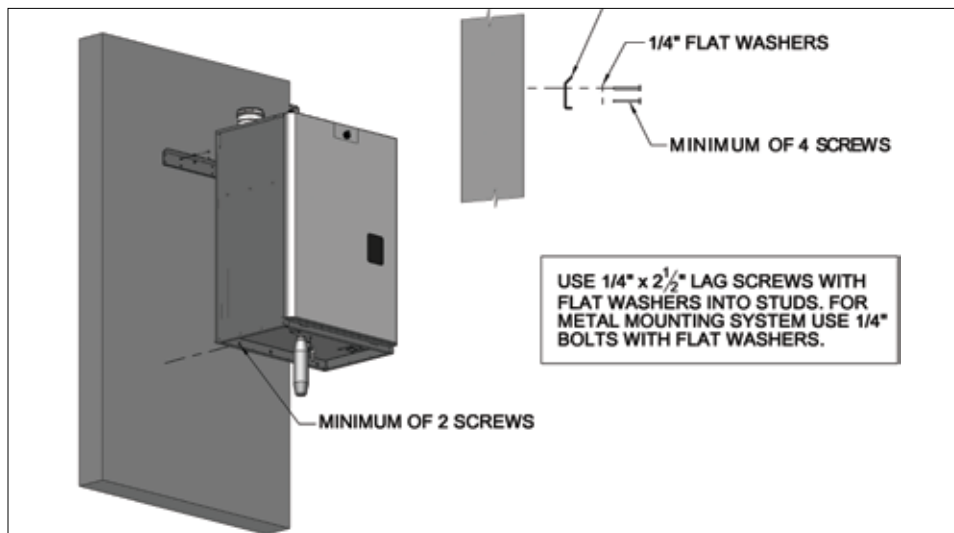

Figure 2: Wall mounting of boiler

⚠ WARNING

Venting, condensate drainage, and combustion air systems for all IBC boilers must be installed in compliance with all applicable codes and the instructions of their respective Installation Manuals.

Inspect finished vent and air piping thoroughly to ensure all are airtight and comply with the instructions provided and with all requirements of applicable codes.

Failure to comply will result in severe personal injury or death.

⚠ DANGER

Do not common vent SL series modulating boilers with any other existing or new appliance.

1.4 EXHAUST VENTING AND AIR INTAKE

It is important to carefully plan the installation to ensure the appropriate vent materials, travel and termination decisions are included. Specific attention is warranted to manage the impact of the steam plume normally experienced at the exhaust terminal of a condensing boiler. Generally, intake and exhaust pipes should terminate at a rooftop or sterile wall location, to maximize customer satisfaction. Keep exhaust plumes well away from all building air intakes including those of neighboring properties.

All venting must be installed in accordance with the requirements of the jurisdiction having authority: in Canada, Part 8, Venting Systems of the B149.1-10 Code and any other local building codes are to be followed. In the USA, the National Fuel Gas Code, ANSI Z23.1, latest edition, prevails. Where there is a discrepancy between the installation instructions below, and the code requirements, the more stringent shall apply.

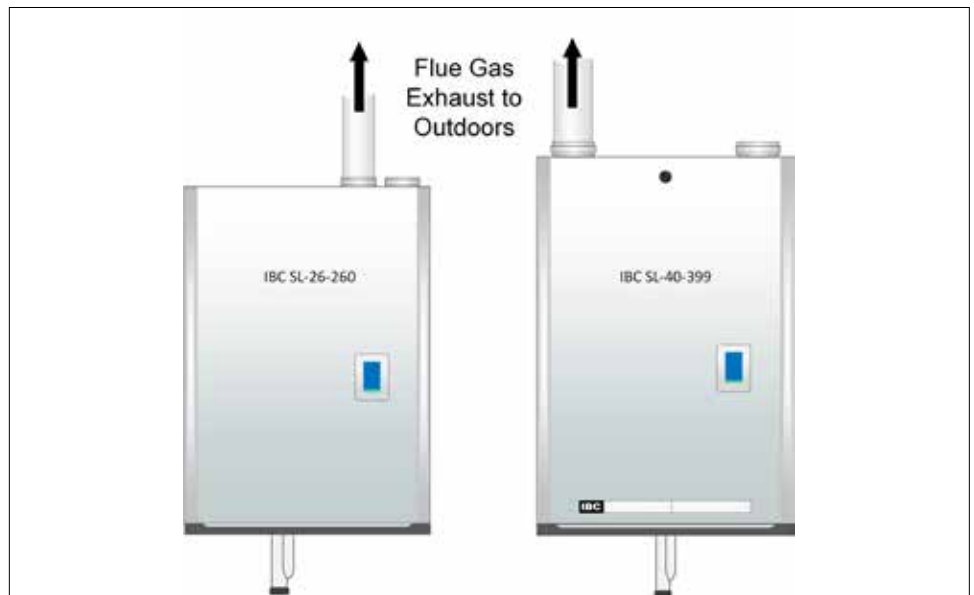

Figure 3: Flue gas venting

Provisions for the combustion and air ventilation must be in accordance with the section "Air for Combustion and Ventilation" of the National Fuel Gas Code, ANSI Z23.1/NFPA 54, or Clause 8.2, 8.3 or 8.4 of the Natural Gas and Propane Installation Code, CAN/CSA B149.1, or applicable provisions of the local building codes.

IMPORTANT:

When an existing boiler is removed from a common venting system, the common venting system is likely to be too large for proper venting of the appliances that remain connected to it.

When resizing any portion of the common venting system, the common venting system should be resized to approach the minimum size using the appropriate tables in the National Fuel Gas Code, ANSI Z23.1 - latest edition. In Canada, use the B149.1 Installation Code.

At the time of removal of an existing boiler the following steps shall be followed with each appliance remaining connected to the common venting system placed in operation, while the other appliances remaining connected to the common venting system are not in operation.

- Seal any unused opening in the common venting system.
- Visually inspect the venting system for proper size and horizontal pitch and determine there is no blockage or restriction, leakage, corrosion and other deficiencies that could cause an unsafe condition.
- Insofar as is practical, close all building doors and windows and all doors between the space in which the appliances remaining connected to the common venting system are located and other spaces of the building. Turn on clothes dryers and any appliance not connected to the common venting system. Turn on any exhaust fans, such as range hoods and bathroom exhausts, so they will operate at maximum speed. Do not operate a summer exhaust fan. Close fireplace dampers.
- Place in operation the appliance being inspected. Follow the lighting instructions. Adjust the thermostat so that the appliance operates continuously.
- After it has been determined that each appliance remaining connected to the common venting system properly vents when tested as outlined above, return doors, windows, exhaust fans, fireplace dampers and any other gas-burning appliance to their previous condition.
- Any improper operation of the common venting system should be corrected so the installation conforms with the National Fuel Gas Code, ANSI Z223.1 - latest edition. In Canada, all installations must conform with the current CAN/CGA - B149.1-10 Installation Code and/or local codes.

⚠ WARNING

Covering non-metallic vent pipe and fittings with thermal insulation shall be prohibited.

⚠ WARNING

Condensate can cause corrosion of metal roofing components and other roofing materials. Check with the builder or roofing contractor to ensure that materials will be resistant to acidic condensate. pH levels can be as low as 3.0

1.4.1 Applications

All SL series boilers are approved with alternative venting options: either 2-pipe Direct Vent or Vent pipe with Indoor Air, offering flexibility to meet the specific requirements of the installation. With the Direct Vent case, combustion air is piped directly to the boiler's air intake from outdoors (*see Section 1.4.7 for air intake piping requirements*). Using the indoor air alternative, air for combustion is drawn from the indoor air surrounding the boiler.

Provided the maximum overall vent length limit is not exceeded, the installer may choose to vent the boiler through the wall, directly through the roof, or upward using an existing - but otherwise unused - chimney as a vent raceway.

1.4.2 Exhaust Vent Material

Exhaust Vent Material – CANADA

Use PVC, CPVC or Polypropylene (PPs) vent component systems approved under ULC-S636 Standard for Type BH Gas Venting Systems, or stainless steel Type BH venting systems*. The vent temperature is limited with the use of a flue temperature sensor and software to ensure the maximum temperature of the PVC venting material is not exceeded.

Exhaust Vent Material – USA

PVC, CPVC or PPs venting materials are approved for use with these boilers in most of the USA. Check local codes to determine if any materials are prohibited. The vent temperature is limited with the use of flue temperature sensor and software to ensure that the maximum temperature of the PVC venting material is not exceeded. PVC venting material shall be certified to Sch. 40 ASTM D1785 or D2665. CPVC material shall be certified to Sch. 40/ASTM F441.

Do not use ABS or any cellular core pipe for exhaust venting.

Use of cellular core PVC (ASTM F891), cellular core CPVC, or Radel® (polyphenolsulfone) in venting systems shall be prohibited.

⚠ WARNING

Do not mix PPs venting materials from different Manufacturers.

These venting materials are designed to be installed as part of a complete system.

Failure to comply may result in severe personal injury or death.

⚠ WARNING

Fully insert the approved venting material into the boilers exhaust outlet and tighten clamp to ensure the venting connection is locked in place.



The boiler offers 3" or 4" venting connections. Fittings are to be used to adapt to the appropriate diameter – see Vent Travel below. Exhaust venting is to be inserted directly into the 3" or 4" female stainless steel fitting (see Figure 3).

For PPs material, use the transition / adaptor fitting (Sch 40 to PPs) offered by the respective PPs manufacturers Centrotherm / Innoflue™ (their part # ISAA0303 or # ISAA0404) or M&G Dura Vent / PolyPro™ (# 3PPs-AD), (# 4PPs-AD) or Z-Flex/Z_DENS (# 2ZDCPVCG3). For PPs material exposed to outdoor weather, follow the venting supplier's recommendations on UV protection.

Combustion air piping - if used - is inserted directly into the 3" or 4" female stainless steel fitting (see Section 1.4.7).

Venting shall be supported in accordance with the applicable code.

*Manufacturers of stainless steel Type BH venting systems must submit their approved transition fitting to IBC for evaluation and written approval.

1.4.3 Vent Travel

PVC/CPVC or PPs (Rigid Single Wall) or Schedule 40 approved piping is the standard venting option; with this, the boilers can be sited up to 200 equivalent feet from the vent termination. The actual vent travel allowance is reduced for fittings in accordance with the following tables. For example, for an SL 40-399 G3 using 6 x 90° CPVC vent elbows, the maximum lineal measure of pipe allowed is 152 feet (200' – (6 x 8' = 48) = 152').

SL 26-260 G3	
EXHAUST PIPE SIZE	MAXIMUM EQUIVALENT LENGTH
Sched.40; Rigid PPs	
3"	200' (each side)
90° vent elbow	allow 8' equivalent
90° long sweep elbow	allow 5' equivalent
45° elbow	allow 3' equivalent
PPs 87-90° elbows	use 8' equivalent
3" Stainless Sidewall Terminal (SST) IBC P/N 180-149 (P-257)	allow 20' equivalent of 3" Sched. 40
Flexible PPs	
3" PPs Flexible	60' (max.) actual lineal x 3.33 = equivalent

Table 3A: Maximum Exhaust Venting Length for SL 26-260 G3

SL 40-399 G3	
EXHAUST PIPE SIZE	MAXIMUM EQUIVALENT LENGTH
Sched.40; Rigid PPs	
4" CPVC / Rigid PPs	200' (each side)
90° vent elbow	allow 8' equivalent
90° long sweep elbow	allow 5' equivalent
45° elbow	allow 3' equivalent
PPs 87-90° elbows	use 8' equivalent
3" Stainless Sidewall Terminal (SST) IBC P/N 180-149 (P-257)	allow 65' equivalent
3" CPVC (to adapt to the SST)	for each 1' allow 3.2' equivalent
Flexible PPs	
4" PPs Flexible	160' max, using 1.2 x for equivalent length

Table 3B: Maximum Exhaust Venting Length for SL 40-399 G3

For Flexible PPs, up to 160 actual lineal feet are allowed in a nominally vertical orientation (>45°). The equivalent length of 4" Flex PPs shall be computed using a multiple of 1.2:1, e.g. 80' x 1.2 = 96' equivalent (with such use of 80' of 4" Flex, up to 104' equivalent of 4" Rigid PPs would still be allowed). PPs 87-90° elbows are considered equivalent to 8'.

NOTE: Unused intake travel cannot be added to the exhaust. Unequal intake and exhaust piping is allowed - see Section 1.4.8.

Exhaust venting must slope down towards the boiler with a pitch of at least 1/4" per foot (PPs vent: follow PPs manufacturer requirements for slope), so condensate runs back towards the trap. Support should be provided for intake and vent piping, particularly so for horizontal runs (follow local code).

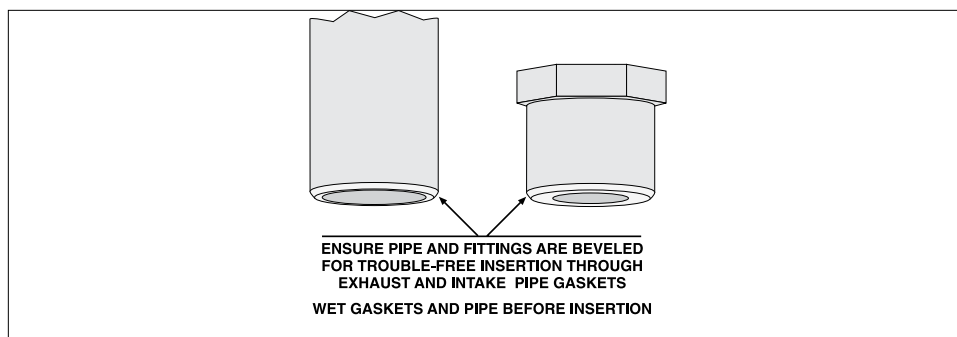

Figure 4: Pipe and fitting beveling

Ensure all venting components are clear of burrs/debris prior to assembly. Care is to be taken to avoid ingestion into the fan of plastic debris left in the combustion air piping.

All joints must be secured using appropriate solvent cement to bond the respective pipe material (Canada: CPVC cement approved under ULC-S636, in accordance with its manufacturer instructions; USA: PVC (ASTM D2564), or PVC/ABS (D2235) - Use transition glue anywhere that PVC and CPVC are joined. Follow the cement manufacturer's instructions closely when joining various components. For PPs, connections shall be secured using approved retainer clips supplied by the respective PPs manufacturer.

⚠ WARNING

Follow all installation instructions supplied by the pipe and fitting manufacturer.



Figure 5A: 26-260 Fan control harness plug

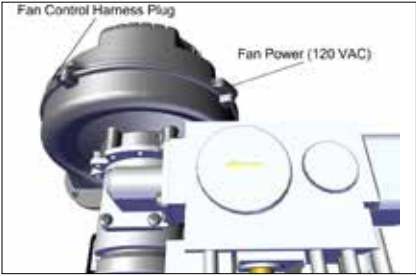

Figure 5B: 40-399 Fan control harness plug

⚠ BEST PRACTICES

To reduce the possibility of expansion noise, allow a 1/4" gap around the exhaust and air intake piping.

⚠ WARNING

Condensate can cause corrosion of metal roofing components and other roofing materials. Check with the builder or roofing contractor to ensure that materials will be resistant to acidic condensate. pH levels can be as low as 3.0

All vent connections must be liquid and pressure tight. Prior to firing the boiler, and before any of the venting run is concealed by the building construction, the installer must test the exhaust joints under fan pressure with the vent blocked, using a soap and water solution. The installer must fill the condensate trap prior to testing.

To drive the fan into manual high speed operation for vent leak testing, unplug the fan control harness plug (see Figures 5A and 5B), and then block the vent outlet so that the vent run will be under maximum fan pressure. Paint all joints with an approved leak test solution just as you would joints in a gas line, and make sure there are no leaks. Good practice would suggest that the installer attach a tag on the vent line near the condensate drain tee indicating the type of test, the date and the installer's name.

1.4.4 Venting Passage Through Ceiling and Floor

- Confirm material meets local codes including fire stopping requirements.
- Some local jurisdictions require a minimum initial length of pipe be exposed or accessible for inspection.
- Pipe clearances - no IBC requirements; follow local codes.
- All piping must be liquid and pressure tight.

1.4.5 Rooftop Vent Termination

- a) Rooftop vents must terminate as follows:
 - The exhaust pipe can terminate in an open vertical orientation without concern about rain infiltration; rain will drain away through the condensate trap.
 - Optional bird screen may be placed in a termination fitting. Leave unglued, and hold in place with a short nipple. This permits easy access for cleaning.
 - DO NOT exhaust vent into a common venting system.
- b) For Rooftop Direct Vent systems:
 - Rooftop, two pipe, direct vent configurations, including typical clearance requirements, are shown in Figure 8.
 - The intake air pipe is not typically drained, so it must be terminated with a down-turned elbow (see Figure 8).
 - The intake pipe does not need to penetrate the roof at the same elevation as the exhaust (as shown); lower down on the roof is acceptable.
 - For roof top venting of multiple boiler sets, group all intake terminals together for a common penetration through a custom cap. Alternatively, place in the closest proximity achievable using commonly available pipe flashing. Similarly group the exhaust pipes and place the two separate groups of pipes at least 3' apart (the closest intake and exhaust pipes shall be 36", or more, apart). Use the same 12" (minimum) vertical separation for all termination options. For alternate group terminations, contact the IBC Factory for written guidance.
 - Roof Top Concentric Termination kits are approved for use with the boiler model. The installation of the vertical roof top concentric termination must follow the installation instructions supplied with the venting material manufacturer. Care must be taken to install the termination kit a minimum horizontal distance of 10' (305cm) away from any portion of the building and a minimum of 2' (61cm) above the roof line plus the anticipated snow line.

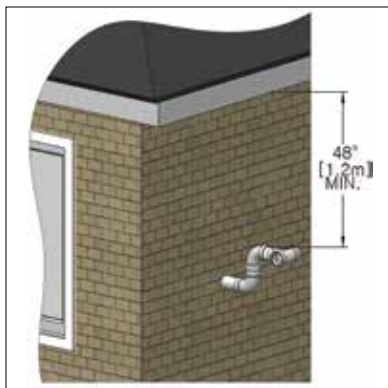

Figure 6: IBC recommended minimum vent terminal clearance under ventilated soffit

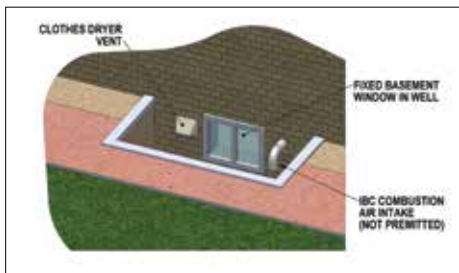

Figure 7: Prohibited installation

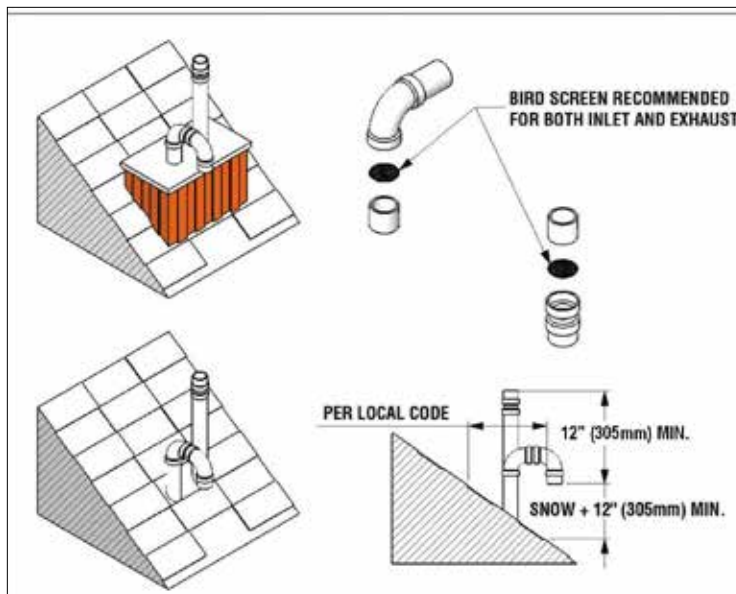
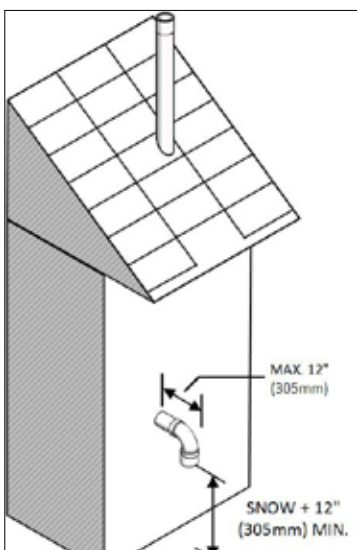

Figure 8: Rooftop vent terminal configurations

1.4.6 Sidewall Vent Termination

a) Vent terminal clearance minimums are as follows:

- The exhaust vent terminal is to be placed 18" minimum (12" in USA) above the grade or anticipated snow level.
- Clearance above grade, veranda, porch, deck or balcony – 12" (0.3m), but check local code also (anticipated snow levels may supersede).
- Clearance to openable window or door – 36" (0.91m) (USA – 12")
- Vertical clearance to ventilated soffit located above the terminal - 48" (1.2m). See Caution note in this section.
- Clearance to each side of centre line extended above meter/regulator assembly: - 3' (0.91m) within a height of 15' (4.6m) above the meter/regulator.
- Clearance to service regulator vent outlet: - 3' (0.91m)
- Clearance to non-mechanical air supply inlet to building or the combustion air intake to any other appliance: - 3' (0.91m) (USA – 12" (0.3m))
- Clearance to a mechanical air supply inlet: - 6' (1.82m) (USA - 3' (0.91m) above if within 10' (3.1m) horizontally)
- Clearance above paved sidewalk or paved driveway located on public property: - 7' (2.2m) Note: Cannot terminate directly above a paved sidewalk or paved driveway that is located between two single family dwellings and serves both dwellings
- Clearance under veranda, porch, deck or balcony: - 12" (0.3m) IBC strongly recommends a minimum of 24" with the boilers to avoid damage to the structure. Note: Prohibited unless fully open on a minimum of two sides below the floor.
- Vents must be installed such that flue gas does not discharge towards neighbor's windows, or where personal injury or property damage can occur.
- It is important to ensure proper condensate management from vent terminations. Condensate shall not be discharged in a manner that will cause damage to external building finishes or components, or infiltrate building envelopes, including adjacent structures.



Rooftop vent termination with sidewall combustion air

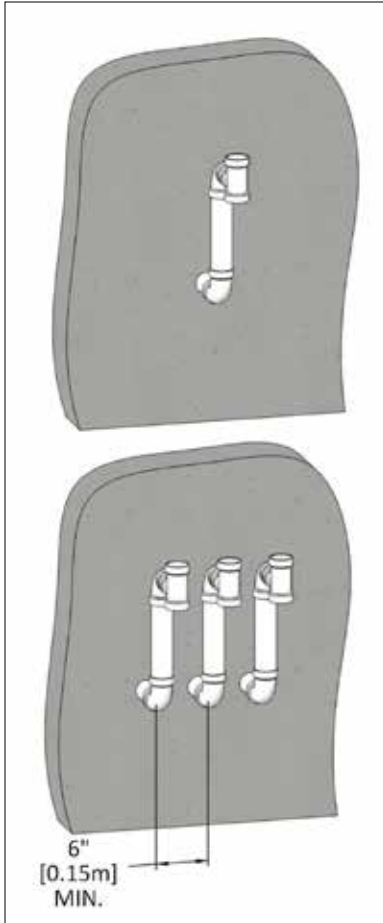

Figure 9: Sidewall vent termination - indoor combustion air applications

CAUTION

Vent termination clearances in this section are code minimum, or IBC recommended minimum requirements, and may be inadequate for your installation. Building envelope details must be examined carefully, and ingress of moisture into building structures is to be avoided. Serious structural damage may occur if adequate precautions and clearances are not allowed for.

These precautions are to be observed for neighboring structures as well as for the structure the boiler(s) are installed in.

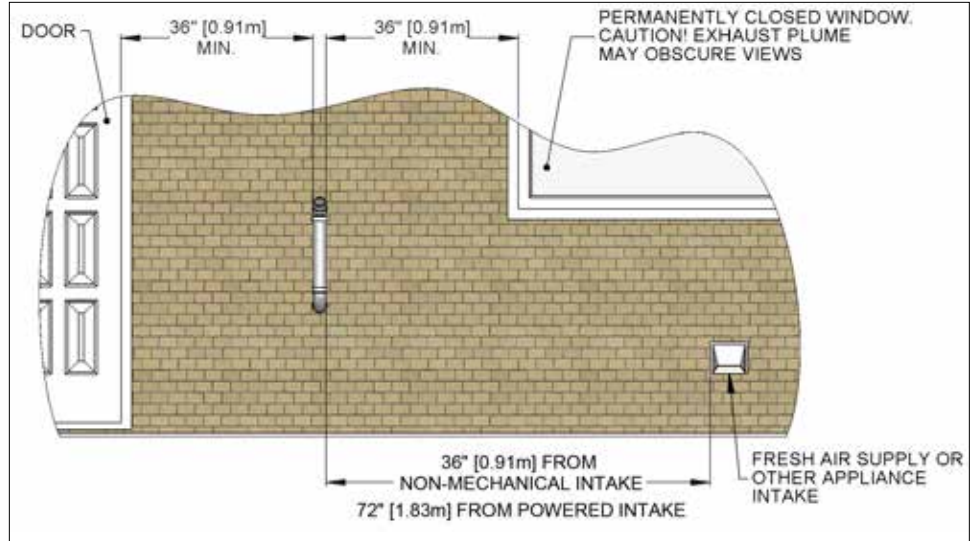

Figure 10: Vent terminal clearances

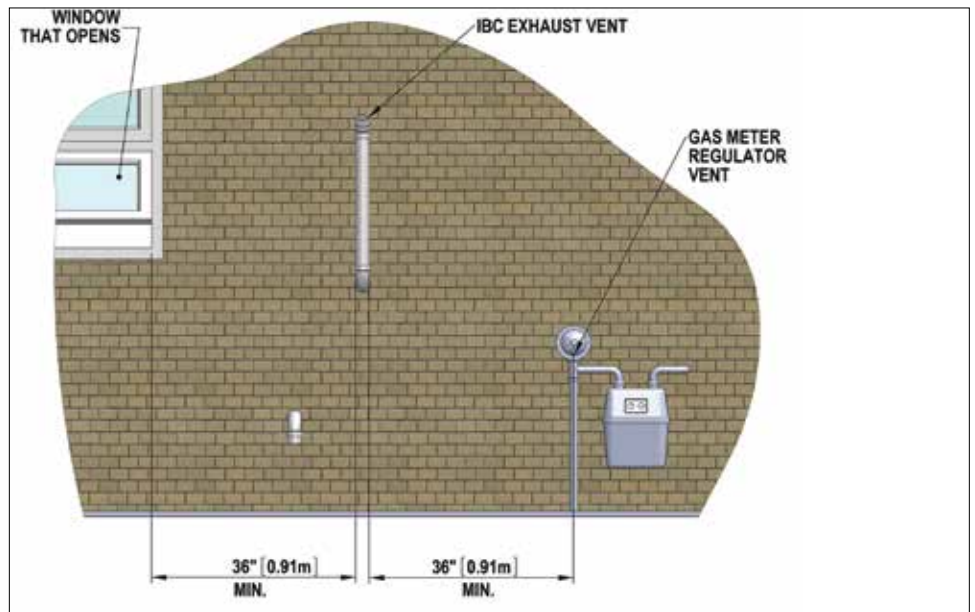

Figure 11: Vent terminal clearances

b) Sidewall vent termination for indoor combustion air applications shall be as follows:

- The vent shall be terminated with a tee fitting as illustrated - See Figure 9.
- Bird screen of 1/4" stainless steel or plastic mesh (IPEX System 636 drain grate) should be installed in both open ends of the tee.

⚠ WARNING

It is extremely important to maintain at least the minimum separation of exhaust vent termination from boiler intake air as illustrated in figures 12 and 13. Failure to do so can result in a dangerous situation where exhaust gasses are re-ingested with combustion air. Damage to the boiler can result from a failure to maintain these separations. Third party vent termination kits and concentric wall penetration kits that do not maintain these minimum separations shall **NOT** be used. Improper installation will void the warranty. Do not use proprietary *InnoFlue* or *PolyPro* PPs terminals available without specific approval from IBC.

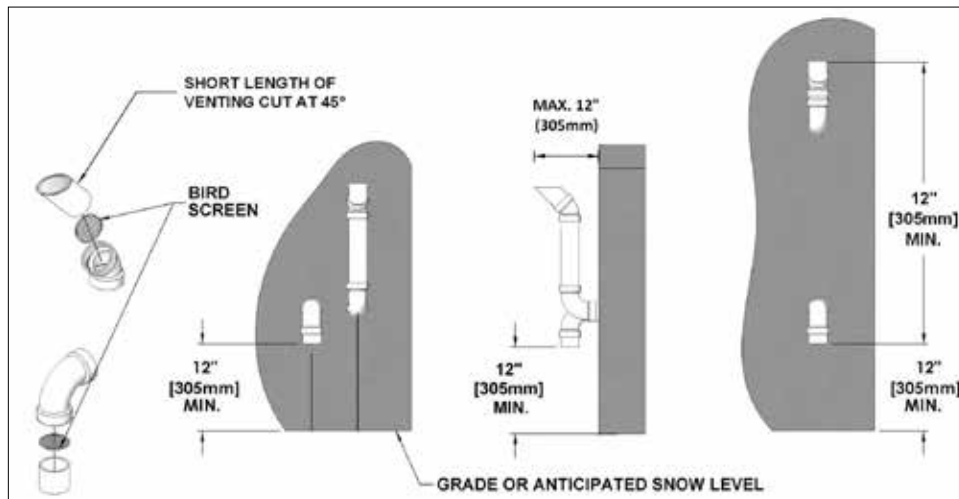

Figure 12: Sidewall vent termination

c) Sidewall Direct Vent with separate vent and air pipes shall be terminated as follows:

- Both the intake air and exhaust vent terminations shall be located on the same plane (side) of the building.
- The exhaust vent termination is to be placed so as to reach 12" minimum above the down-turned intake to avoid exhaust re-ingestion.
- The elevation of both terminations can be raised in "periscope style" after passing through the wall, then configured as in Figure 12 to gain the required clearance.
- Use a 45° elbow on the exhaust termination to launch the plume up and off the sidewall (for protection of wall).
- Bird screen of 1/4" stainless steel or plastic mesh (IPEX System 636 drain grate) is useful to guard against foreign objects.

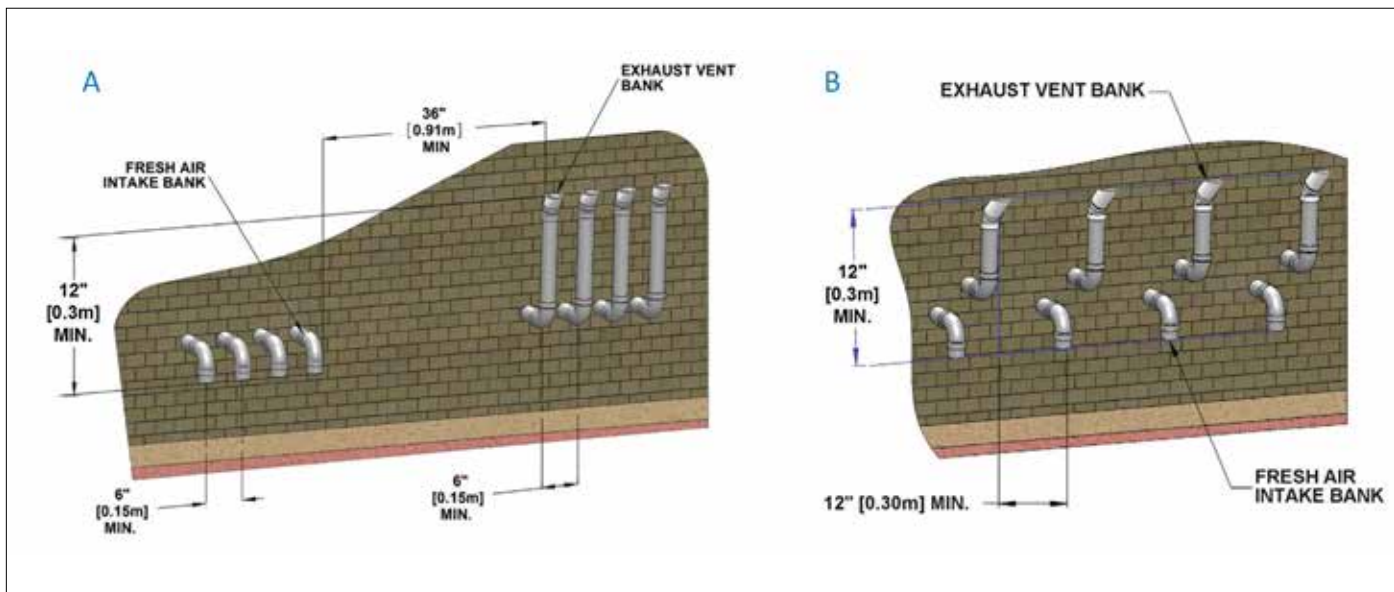

Figure 13: Sidewall vent termination options - multiple vent piping configurations

⚠ WARNING

In areas of high snowfall, users must be advised to check side wall vent and air intake terminations on a regular basis to ensure blockage does not occur.

⚠ CAUTION

Take care installing Concentric Side Wall Termination kits when the outdoor temperature drops below 5°F/-15°C. Possible blockage of the combustion air intake can occur when the outdoor temperature drops below this temperature.

d) Sidewall Direct Vent with Stainless Sidewall Terminal shall be terminated as follows:

- The Stainless Sidewall Terminal (SST) 3 inch IBC part number 180-149 (sold separately included with the IBC kit P-257), is the only direct vent sidewall terminal approved for use with the IBC boiler model.
- The boiler's controller is required to be the Touchscreen type and have software version 1.02.2 or later installed for SST to be used.
- The SST shall be installed in compliance with the minimum vent clearances listed in a) above.
- The installation instructions included with the kit shall be carefully followed.
- The SST shall only be installed with the vent and intake pipes horizontally beside each other or vertically with the vent pipe on top as shown in Figure 14. The vent pipe cannot be installed below the intake. The vent cap must be installed with the openings directed up and down, as shown in Figure 14, and not side to side.
- The SST vent/air connections fit Sched. 40 three inch PVC/CPVC pipe. PPs pipe cannot be used with the SST. The pipes must extend completely through the wall as shown in Figure 15 and immediately inside the wall adapt up to a 4 inch pipe using a standard reducing coupling fitting. Do not use a bushing. The SST is an external fixture, and is not part of the sealed vent system that runs inside the building.
- Ensure that the vent termination location does not exceed the allowed maximum equivalent vent length, including the allowance for the SST, defined in this document section 1.4.3 Vent Travel and section 1.4.7 "Direct Vent" Combustion Air Intake Piping.
- Multiple vent SST installations must be installed level with one another, and maintain at least the minimum separation distances shown in Figures 16 and 17. The Terminals shall not be stacked vertically.
- The two basic methods for supplying combustion air to an IBC boiler are described in sections 1.4.7 and 1.4.8.

e) Approved PVC Side Wall Termination kits are listed below:

- Ipex # 196984 2"
- Ipex # 196985 3"
- Ipex # 196986 4"

These kits are sold separately through the manufacturer.

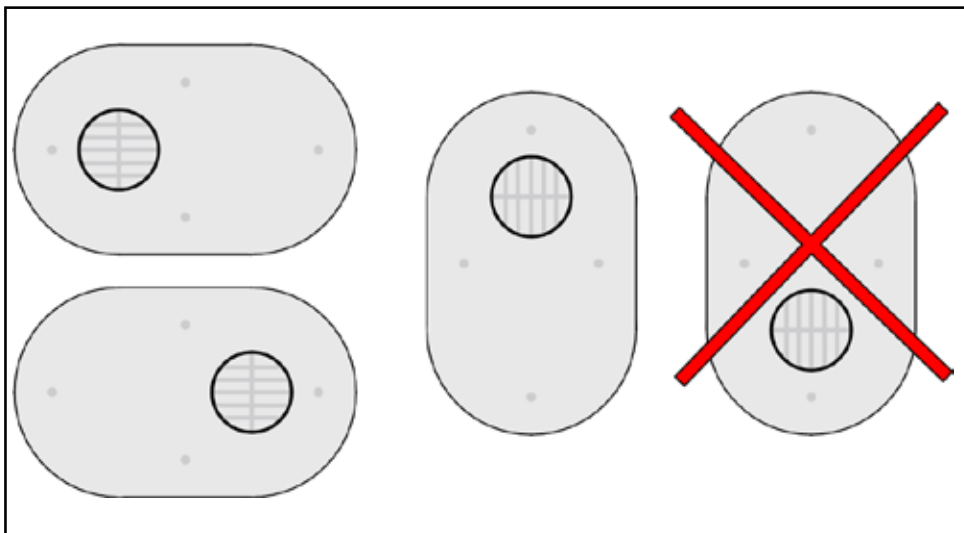

Ipex # 196984 2" PVC, #196985 3" PVC, and # 196986 4" PVC

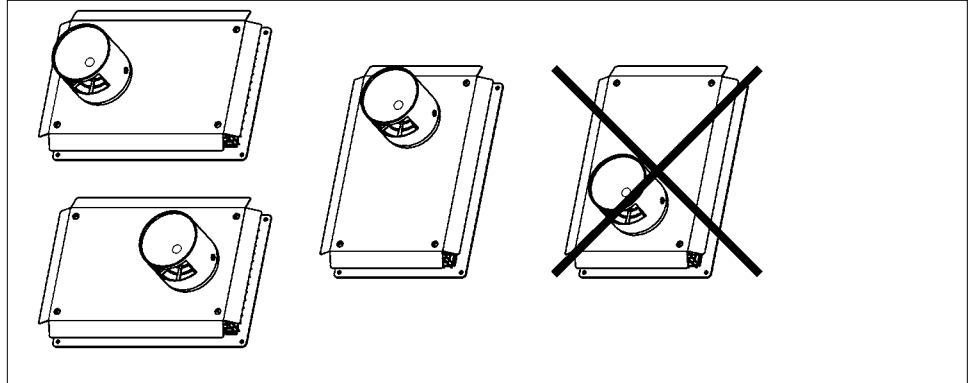

Figure 14: Allowed SST installation orientations

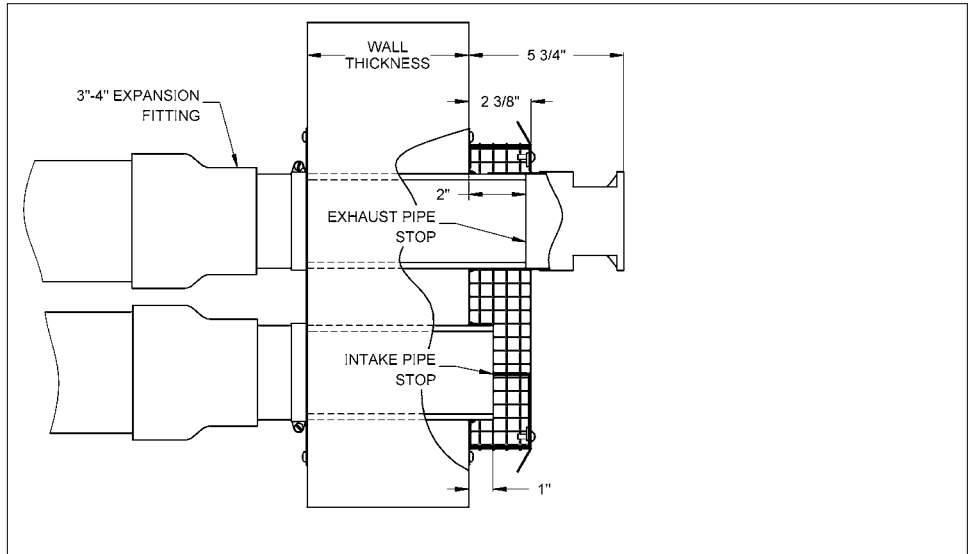

Figure 15: Pipes extend completely through the wall (Vertical orientation shown).

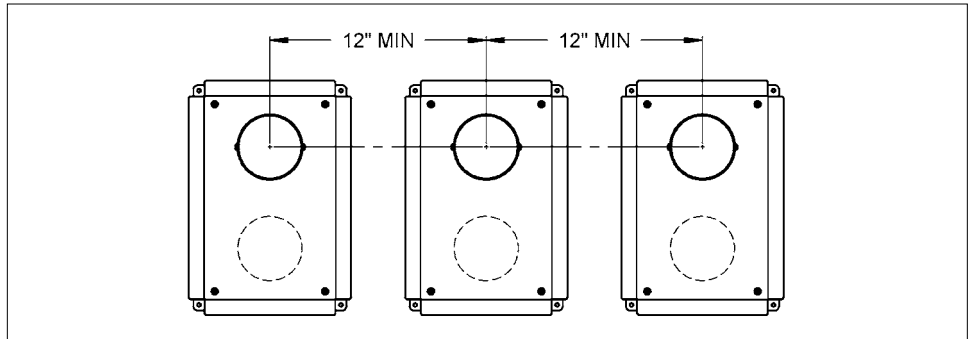

Figure 16: Minimum separation for multiple vent installation - vertical orientation

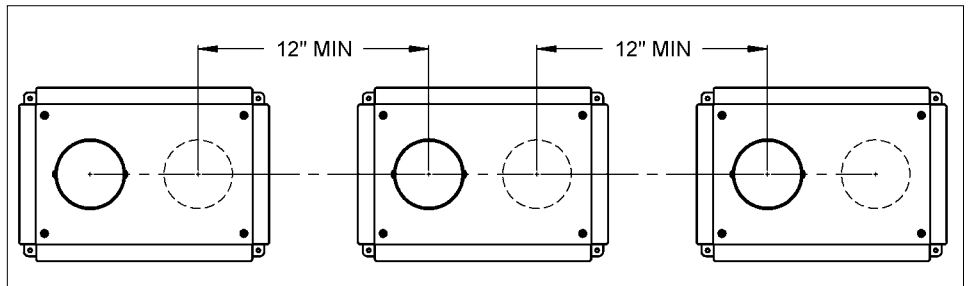

Figure 17: Minimum separations for multiple vent installation - horizontal orientation

⚠ WARNING

In addition to preventing ingestion of chemical contaminants, ensure air intake terminals are not installed in locations where contamination might occur due to ingestion of particulate foreign material (dust, dirt and debris).

⚠ WARNING

Intake air openings must be configured such that rain or other forms of moisture cannot enter the air intake piping system. Otherwise serious damage to the boiler may result.

⚠ NOTE

When installing air intake piping, ensure that a “trap” is not formed in the piping so as to allow a build-up of water, and blockage of intake air.

Such blockage will result in a boiler safety shut-down.

⚠ NOTE

Combustion fan blockages can occur when environmental particulate and foreign matter contaminants (leaves, dust, dandelion & cottonwood fluff, etc) are drawn into the air intake. Where you anticipate this to be an issue, consider intake air filtration (contact the factory).

Check and clean/replace filters on a regular schedule based on the severity of the problem.

1.4.7 “Direct Vent” Combustion Air Intake Piping

The direct vent option uses piping from the outside to supply combustion air directly to the boiler’s combustion air connection.

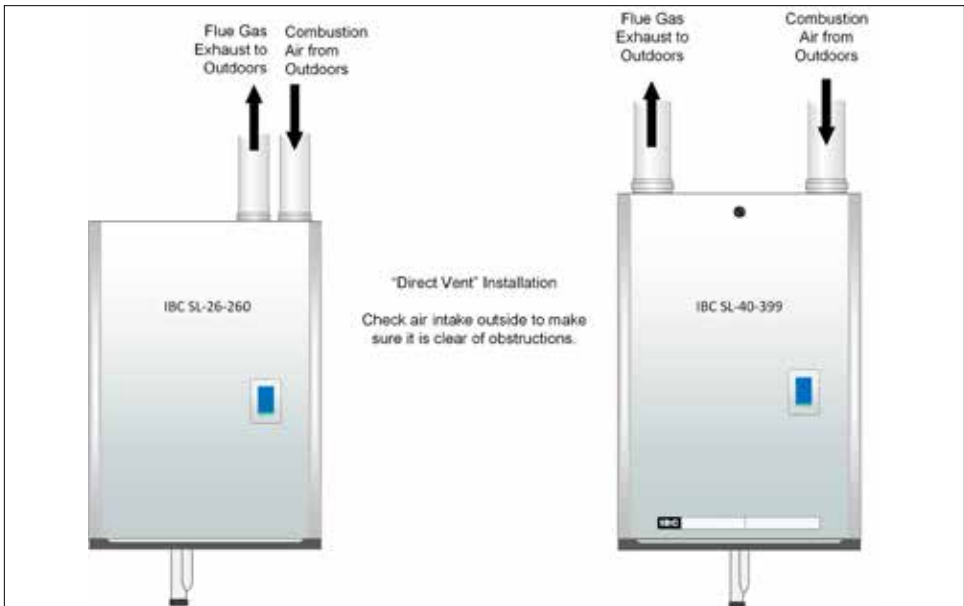

Figure 18: Direct vent combustion air intake

SL 26-260 G3	
INTAKE PIPE SIZE	MAXIMUM EQUIVALENT LENGTH
Sched.40; Rigid PPs	
3"	200' each side
90° vent elbow	allow 8' equivalent
90° long sweep elbow	allow 5' equivalent
45° elbow	allow 3' equivalent
PPs 87-90° elbows	use 8' equivalent
3" Stainless Sidewall Terminal IBC P/N 180-149 (P-257)	No additional allowance required
Flexible PPs	
3" PPs Flexible (SL 26-260 G3)	60' max., actual lineal x 3.33 = equivalent

Table 4A: Maximum Intake Pipe Venting Length for SL 26-260 G3

NOTE

It is not permitted to add to the exhaust length by transfer of unused intake allowance.

NOTE

Combustion air piping - if used - is inserted directly into the 4" female stainless steel fitting on the top, right side of the boiler and runs horizontally or vertically to the outdoors. Screen material can be placed at the inlet as appropriate for the environment (e.g. insects, dust).

WARNING

When using indoor air options, supply adequate combustion air to the boiler room according to the requirements of all applicable codes.

SL 40-399 G3

INTAKE PIPE SIZE	MAXIMUM EQUIVALENT LENGTH
Sched.40; Rigid PPs	
4" CPVC / Rigid PPs	200' (each side)
90° vent elbow	allow 8' equivalent
90° long sweep elbow	allow 5' equivalent
45° elbow	allow 3' equivalent
PPs 87-90° elbows	use 8' equivalent
3" Stainless Sidewall Terminal IBC P/N 180-149 (P-257)	No additional allowance required
3" PVC (to adapt to SST)	for each 1' allow 3.2' equivalent
Flexible PPs	
4" PPs Flexible	160' max, using 1.2 x for equivalent length

Table 4B: Maximum Intake Pipe Venting Length for SL 40-399 G3

For the inlet air – 4" Schedule 40 PVC, CPVC, ABS, or PPs piping of any type is permitted.

Ensure that adequate separation is maintained between the air intake inlet and the vent terminal. Refer to the vent terminal configuration drawings in the Vent Termination section above.

Use support for intake piping, particularly so for horizontal runs (follow the local code).

1.4.8 “Indoor Air” Combustion Air Intake

An “Indoor Combustion Air installation”, as described herein, is one in which air for combustion is taken from the ambient air around the boiler.

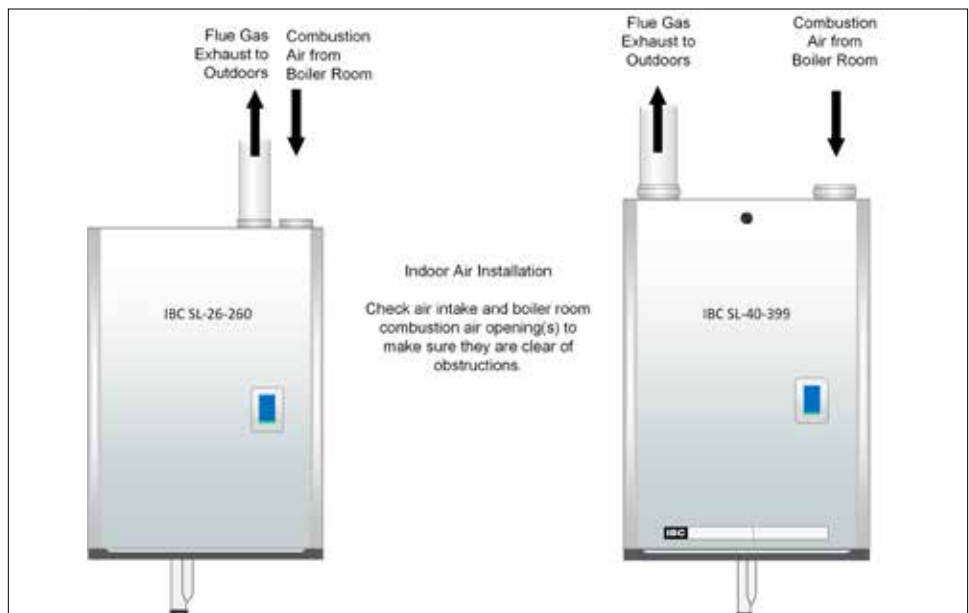

Figure 19: Indoor combustion air intake

To support combustion, an ample air supply is required. This may require direct openings in the boiler room to the outside. If the boiler is not in a room adjacent to an outside wall, air may be ducted from outside wall openings.

Provisions for combustion and ventilation air must be made as follows:

- in the USA, in accordance with the National Fuel Gas Code, ANSI Z223.1 (latest edition), or applicable provisions of the local building codes
- in Canada, in compliance with B149.1

1.4.9 Combustion Air Filtration

If combustion air contamination from ingested particulate matter is a concern in any installation, an optional air intake filter may be installed.

IMPORTANT: Under no circumstances should a third-party air filter be installed on an IBC boiler without proper evaluation and written approval of the IBC Engineering Department.

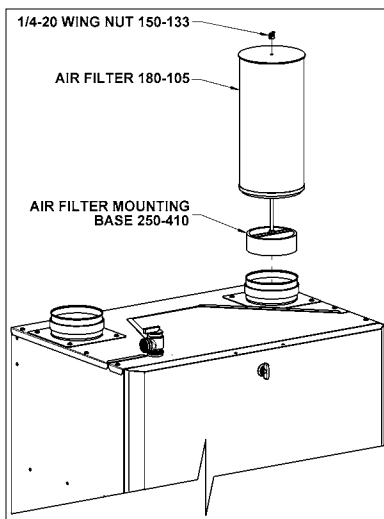

Figure 20: Air Intake Filter Assembly P-172

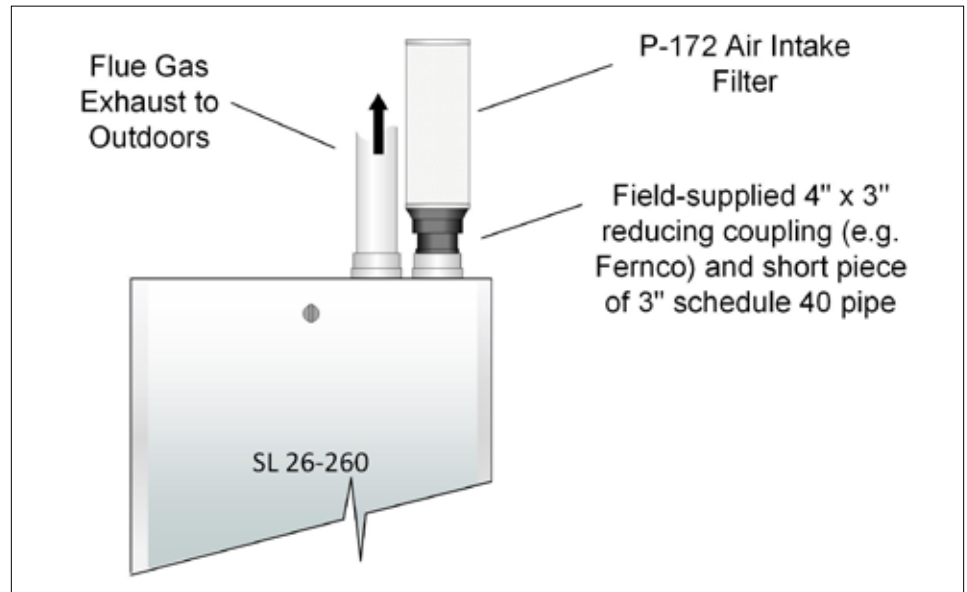

Figure 21: Combustion air intake

1.4.10 Closet Installations

For installations in a confined space (such as a closet), consider ventilation openings through a door or wall to prevent excessive heat from building up inside the space.

Boilers must not be exposed to surrounding conditions above 122°F (50°C) or below 32°F (0°C).

⚠ WARNING

Fill trap with water before boiler is first fired to prevent exhaust fumes from entering room. Never operate the boiler unless the trap is filled with water.

Failure to comply will result in severe personal injury or death.

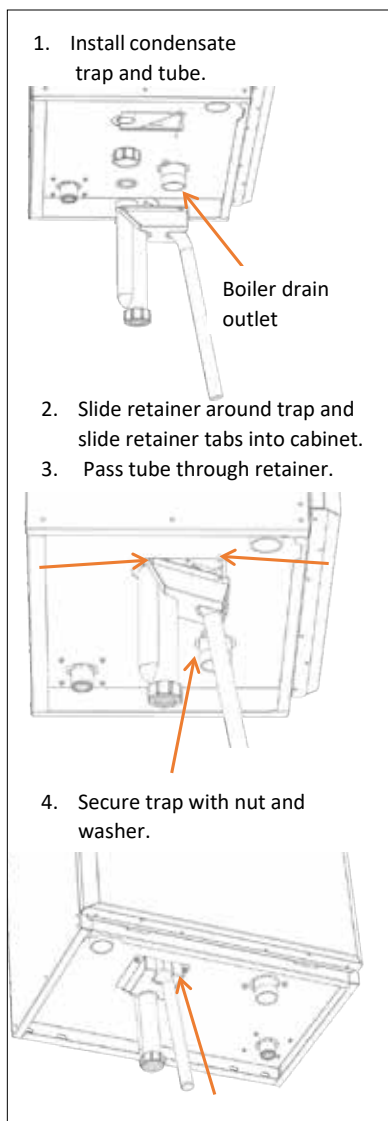

Figure 22: Condensate trap installation

⚠ WARNING

The Trap Door must be installed as instructed and all trap fittings must be tightened as instructed to prevent leakage of flue gasses.

Failure to comply may result in severe personal injury or death.

1.5 CONDENSATE REMOVAL

IBC's specified vent configuration promotes the safe drainage of moisture from the boiler and exhaust venting without flowing liquids back through the heat exchanger (as done by some other condensing boilers).

Reliable system operation requires (1) proper design and installation of exhaust venting to allow condensate to run back to the drain/trap; (2) acid neutralization as appropriate. To achieve these:

- Allow for a 1/4" per foot slope back to the vent connection, with appropriate hangers to maintain that gradient.
- Ensure the supplied trap is correctly installed and filled with water.
- When required, add (and maintain in good condition) a neutralization tank.

1.5.1 Condensate Trap

The condensate trap must be installed on the drain connection at the base of the boiler as shown in Figure 22.

1.5.2 Condensate Trap Assembly - Installation

1. Remove the boiler door and remove the condensate trap door by removing the 2 nuts and washers, lower the front of the trap door and slide forward. Undo the Drain Spout Compression Nut (E), remove the Drain Hose (G) from Trap Drain Outlet (F). Place the Vacuum breaker cap (J) over the Vacuum breaker opening and push firmly home. Remove the Upper Compression Nut and Washer (C) and slide over the Boiler Drain Outlet (A).
2. Fill the trap with water and slide the trap body (D) over the Boiler Drain Outlet (A) and tighten. Attach the Drain Hose (G) and tighten the Drain Spout Compression Nut (E).
3. Install the Condensate Trap Door and tighten the 2 hex screws. Check for leaks.

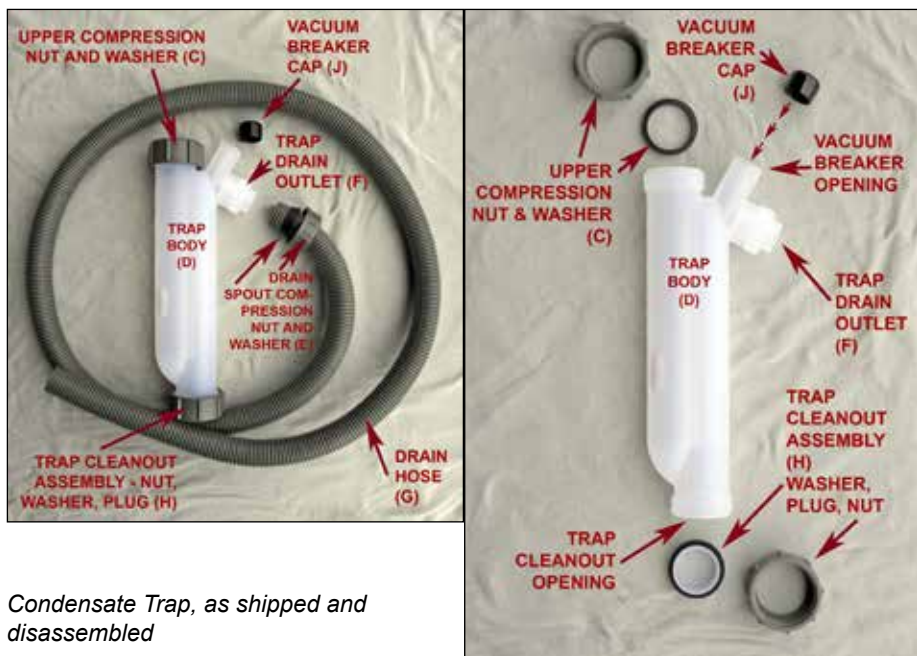

Condensate Trap, as shipped and disassembled

NOTE

It is the responsibility of the installing and/or service Contractor to instruct the end user on how to clean the trap, and to advise that the trap be checked at least every two months and cleaned as required.

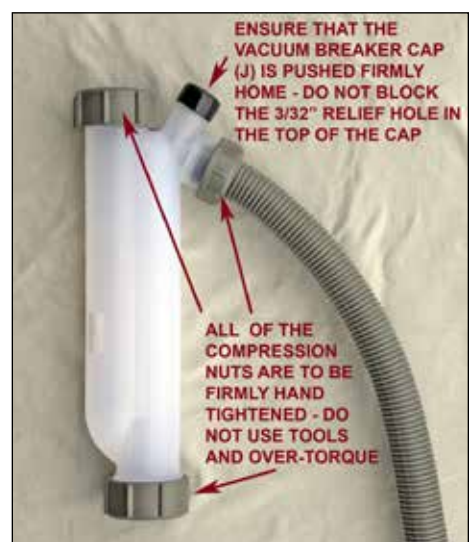

1.5.3 Condensate Trap Assembly - cleaning procedure

1. Turn off the power to the boiler and allow it to cool down.
2. Remove the trap from the boiler (reverse the installation procedure above).
3. Remove the Trap Cleanout Assembly (H) from the Trap Body and clean and flush the debris out.
4. Re-assemble the trap components, re-fill the trap, and replace on the boiler as described in the installation instructions above.

1.5.4 Further installation details

- The condensate drain must be piped to within 1" of a drain or connected to a condensate pump.
- Drainage line must slope down to the drain at a pitch of 1/4" per foot so condensate runs towards the drain.
- Condensate traps should be checked every two months, and cleaned and refilled as necessary.

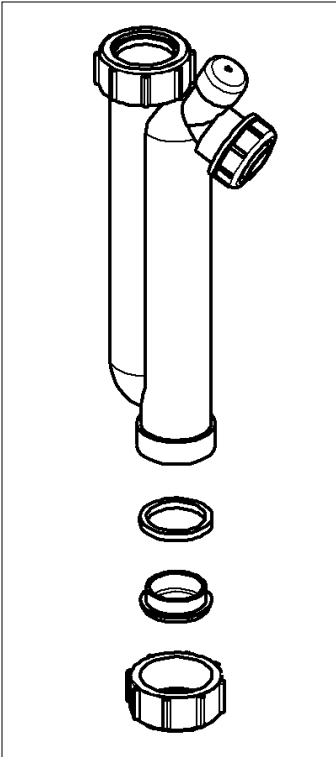

Figure 23: Condensate trap disassembly for cleaning

⚠ WARNING

If condensates are to be discharged into building drain piping materials that are subject to corrosion, use a neutralization package.

⚠ CAUTION

When a condensate neutralization package is installed, the pH of the condensate discharge must be measured on a regular schedule to ensure the neutralizing agent is active and effective.

⚠ DANGER

The water in the condensate neutralizer can cause severe burns to the skin. Use extreme caution when servicing the condensate neutralizer. Wear protective gloves and eyewear.

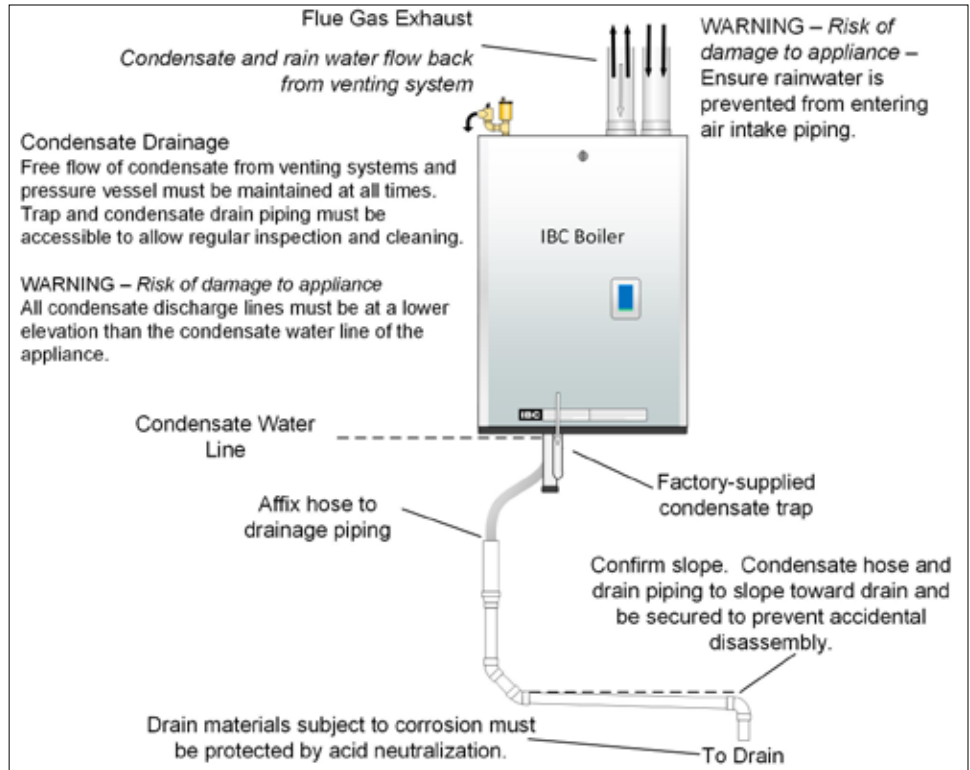

Figure 24 Condensate trap drainage

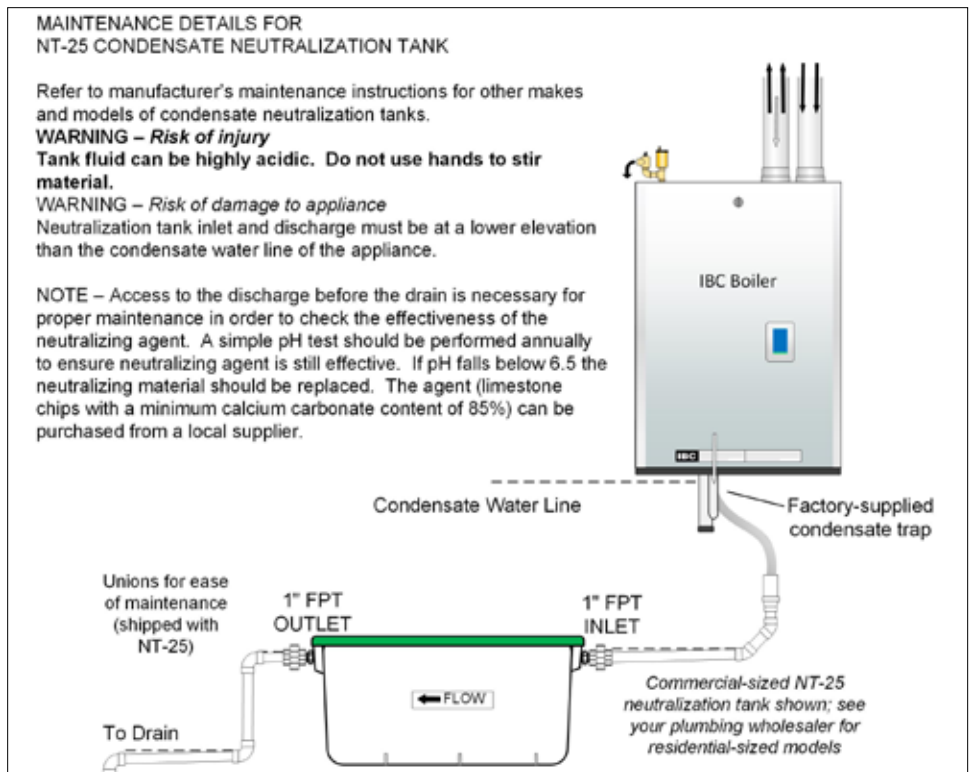

Figure 25: Condensate neutralization tank

⚠ WARNING

During operation, the relief valve may discharge large amounts of steam and/or hot water. Therefore, to reduce the potential for bodily injury and property damage, a discharge line **MUST** be installed that

1. is connected from the valve outlet with no intervening valve and directed downward to a safe point of discharge.
2. allows complete drainage of both the valve and the discharge line.
3. is independently supported and securely anchored so as to avoid applied stress on the valve.
4. is as short and straight as possible
5. terminates freely to atmosphere where any discharge will be clearly visible and is at no risk of freezing.
6. terminates with a plain end which is not threaded.
7. is constructed of a material suitable for exposure to temperatures of 375°F or greater.
8. is, over its entire length, of a pipe size equal to or greater than that of the valve outlet.

DO NOT CAP, PLUG OR OTHERWISE OBSTRUCT THE DISCHARGE PIPE OUTLET!

⚠ CAUTION

Contact local water purveyors about the suitability of the supply for use in hydronic heating systems.

If unsure about water quality, request testing and assessment (and treatment, if required) from a local water treatment expert.

Alternatively, water or hydronic fluid of known quality can be brought to the site.

1.6 WATER PIPING

1.6.1 General Piping Issues

Primary/secondary piping, or the use of a hydraulic separator is recommended for maximum flexibility in multi-load applications, but piping loads in parallel is also encouraged in systems that only have two loads, or when loads are operating simultaneously. The extremely low pressure drop through the SL Series heat exchanger allows many options not available in other designs. In short – IBC has built a boiler that will allow you to pipe the system the way you prefer, rather than try and dictate your piping practices from boiler to radiator.

SL 26-260 G3

These boilers are designed for use within a closed loop, forced circulation, low pressure system. A 30 psi pressure relief valve (3/4" NPT) is supplied for field installation at one of the locations shown in the following illustrations. Relief valve discharge piping must terminate between 6" (15cm) and 12" (30cm) above the floor or per local Code.

SL 40-399 G3

These boilers are designed for use within a closed loop, forced circulation, low pressure system. A 30 psi pressure relief valve (3/4" NPT) is supplied for field installation in the relief valve fitting on top of the boiler. An optional 75 Psig relief valve can be used where required on closed loop systems within multi-level buildings. Relief valve discharge piping must terminate between 6" (15cm) and 12" (30cm) above the floor or per local Code.

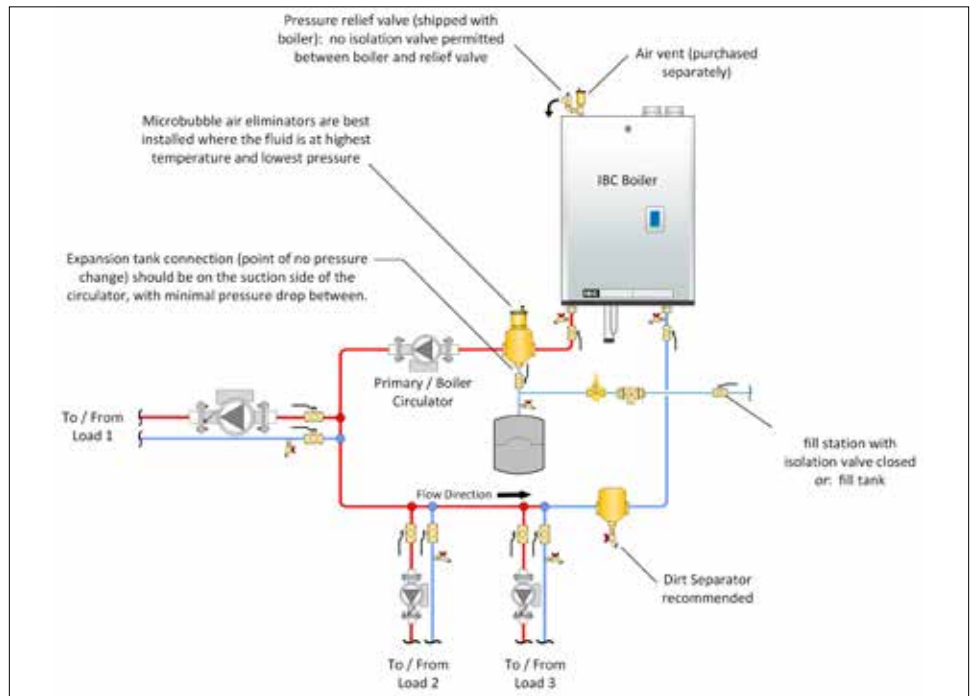

Figure 26: Boiler trim options - Single boiler

System piping is connected to the boiler using the 1 1/2" NPT-M threaded fittings. To simplify servicing, we recommend using unions and gate or ball valves at the boilers supply and return water connections. You must install un-insulated hot water pipes with a minimum 1/4" clearance from combustible materials.

⚠ WARNING

Close fill valve after any addition of water to the system, to reduce risk of water escapement.

Fluid fill is most often accomplished by using a boiler regulator & fill valve set at 12 psig or more, with the appropriate backflow prevention device as required by local code. This is acceptable in areas where municipal water or well water has been treated and filtered to remove excessive minerals and sediment, and water chemistry is known to be suitable for closed loop hydronic systems. In areas where water quality is in question, or when chemical treatment or glycol is required, other options should be considered. Follow the applicable codes and good piping practice.

There are a number of boiler feed and pressurization devices on the market today that may be a better choice than a raw water fill from the mains. When regular maintenance requires relief valve blow-off, the discharge may be directed back into the pressurization unit for recycling of boiler fluid and chemicals back into the system. In buildings that may be unoccupied for long periods of time, pressurization units are useful to prevent flood damage should leakage occur from any component in the system. An additional benefit is that backflow prevention devices are not required when using these devices.

Do not place any water connections above the boiler; leaks can damage the fan and controls. If needed, create a shield over the top of the cover, but allow clearance for airflow and service access.

For best results, use a Primary/Secondary piping system, with a pumped boiler loop using 2" piping. Refer to Tables 5A and 5B for boiler head loss information.

For example in SL 40-399 G3, the minimum flow rate required through the heat exchanger is 20 gpm and a maximum of 45 gpm is allowed. Primary/Secondary piping ensures adequate flow and de-couples ΔT issues (boiler vs. distribution). Aim for a 20° to 30° F ΔT across the heat exchanger at high fire (there is a boiler protection throttle fence limiting the ΔT to 40°F).



Supply stack upper tapping - 3/4" FIP to accept relief valve and air vent assembly



Relief valve and air vent assembly (recommended configuration)

⚠ NOTE

Full sized application drawings can be downloaded from our web site.

www.ibcboiler.com

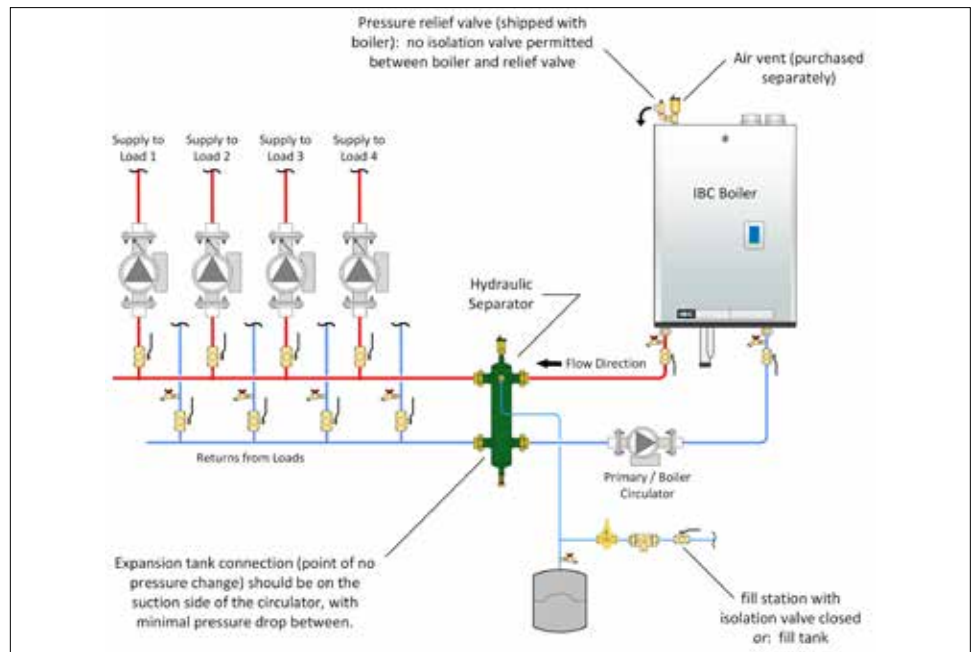

Figure 27: Primary/Secondary piping concept with hydraulic separator

The boilers can supply multiple heating loads with compatible supply temperature requirements. Always ensure that loads sensitive to high temperatures are protected using means such as mixing valves.

⚠ WARNING

Water quality has a significant impact on the lifetime and performance of an IBC Boiler heat exchanger.

Improperly prepared water in a heating circuit may cause damage to the heat exchanger through corrosion or fouling. Repeated or uncontrolled water fills will increase the potential for damage.

High levels of dissolved solids or minerals may precipitate out of the fluid onto the hottest part of the heat exchanger, impairing heat transfer and resulting in overheating and premature failure. The amount of solids that may form on the heat exchanger will depend on the degree of hardness and the total water volume in the system. A high water volume system with a low hardness count may cause as much damage as a system with less volume and higher hardness, so it is recommended to treat water so as to remove all dissolved solids. Other water chemistry allowable limits are as follows:

Acidity pH is to be between 6.6 and 8.5

Chloride is to be less than 125 mg/l

Iron is to be less than 0.3 mg/l

Cu less than 0.1 mg/l

Conductivity is to be less than 400µS/cm (at 77°F (25°C))

Hardness is to be 7 Grains or less

IMPORTANT: Ensure that these limits are acceptable for the other water-side components in the system.

BOILER HEAD LOSS

BOILER HEAD LOSS SL 26-260 G3

Flow rate (gpm)	6	10	15	20	25
Head @ flow (ft wc)	2	3.5	5.5	8	13

Table 5A: Boiler Head Loss

BOILER HEAD LOSS - SL 40-399 G3

Flow rate (gpm)	20	25	30	35	40	45
Head @ flow (ft wc)	1	1.5	2	3	4	6

Table 5B: Boiler Head Loss

Ensure that the pump is rated for the design circulating water temperatures; some pumps have a minimum water temperature rating above the low temperature potential of the boiler. Following installation, confirm the actual performance by measuring ΔT (under high and low flow conditions) after establishing the correct firing rate.

We require water flow after burner shutdown to utilize legacy heat – this is significant due to the mass of the heat exchanger plus its internal water volume. Default software values will run the boiler’s primary pump for up to 5 minutes (300 seconds) after burner shutdown. Secondary pumps can be set to run up to 15 minutes after burner shutdown (for the last calling load). As shipped, the default software will run the Load 1 pump for 5 minutes to place the legacy heat where it is useful. Any secondary pump can be set to run for 0 – 900 seconds in the heat purge mode. Guard against deadheading pumps when all zone valves are closed (see Section 2.7 Set Up & Load Definition).

The primary pump must be under the control of the boiler to allow pump purge after burner shut-down.

Schematics for several piping layouts are provided, and additional drawings are available at www.ibcboiler.com. Installers shall conform the piping design to one of the provided configurations to simplify the control application, promote good loads and flow management.

Propylene glycol solution is commonly used in a closed loop where freeze protection is required. Its density is lower than that of water, resulting in lower thermal performance at a given flow and pressure. As a rule of thumb, a 50%:50% solution of propylene glycol and water will require an increased system circulation rate (gpm up 10%), and system head (up 20%) to provide performance equivalent to straight water.

SL modulating series boilers can be connected directly to a floor of non-oxygen barrier polybutylene material (PB tubing). For maintenance of warranty on such systems, we require evidence of a thorough flushing of all loops, plus installation of a dirt separator or side stream filter. A separator/filter maintenance routine shall be carried out after the retrofit, with filter clearing after the 1st day, 1st week, month and annually thereafter. Care is to be taken to avoid use of ferrous fittings and pumps on Non Oxygen Barrier tube systems.

⚠ WARNING

Do not use automotive-type ethylene or other types of automotive glycol antifreeze, or undiluted antifreeze of any kind. This may result in severe boiler damage. It is the responsibility of the Installer to ensure that glycol solutions are formulated to inhibit corrosion in hydronic heating systems of mixed materials. Improper mixtures and chemical additives may cause damage to ferrous and non-ferrous components as well as non-metallic, wetted components, normally found in hydronic systems. Ethylene glycol is toxic, and may be prohibited for use by codes applicable to your installation location. For environmental and toxicity reasons, IBC recommends only using non-toxic propylene glycol.

⚠ NOTE

The boiler, when used in connection with a refrigeration system, must be installed so the chilled medium is piped in parallel with the boiler with appropriate valves to prevent the chilled medium from entering the boiler.

⚠ NOTE

The boiler piping system of a hot water boiler connected to heating coils located in air handling units where they may be exposed to refrigerated air circulation must be equipped with flow control valves or other automatic means to prevent gravity circulation of the boiler water during the cooling cycle.

1.6.2 Installation Rules

If the installation involves small loads, as in typical zoned baseboard heating applications, use of a buffer tank is recommended. To aid in temperature transition from hot to cool loads, a 3-way mixing valve can be placed at the entrance to the cool load (this will also provide floor protection). This will permit immediate circulation of mixed flow into the cool loop.

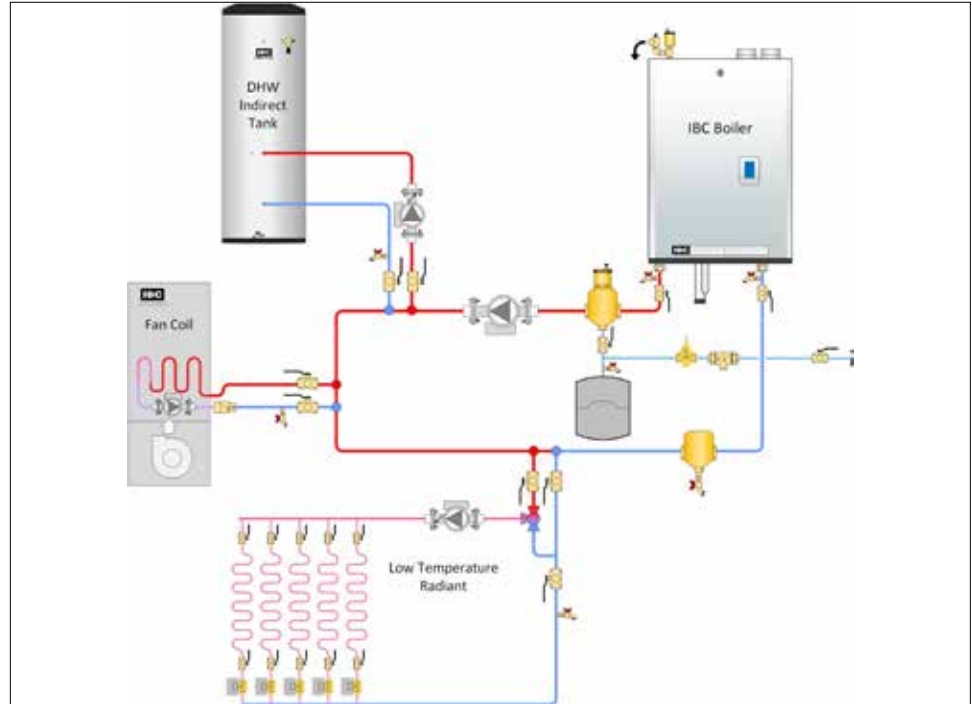

Figure 28: Primary/Secondary piping concept with simultaneous setpoint calls. Always ensure that loads sensitive to high temperatures (e.g. radiant floor) are protected using appropriate means such as a manual mixing valve, or an aquastat (set to 130°F, for example) wired to the boiler’s auxiliary interlocks.

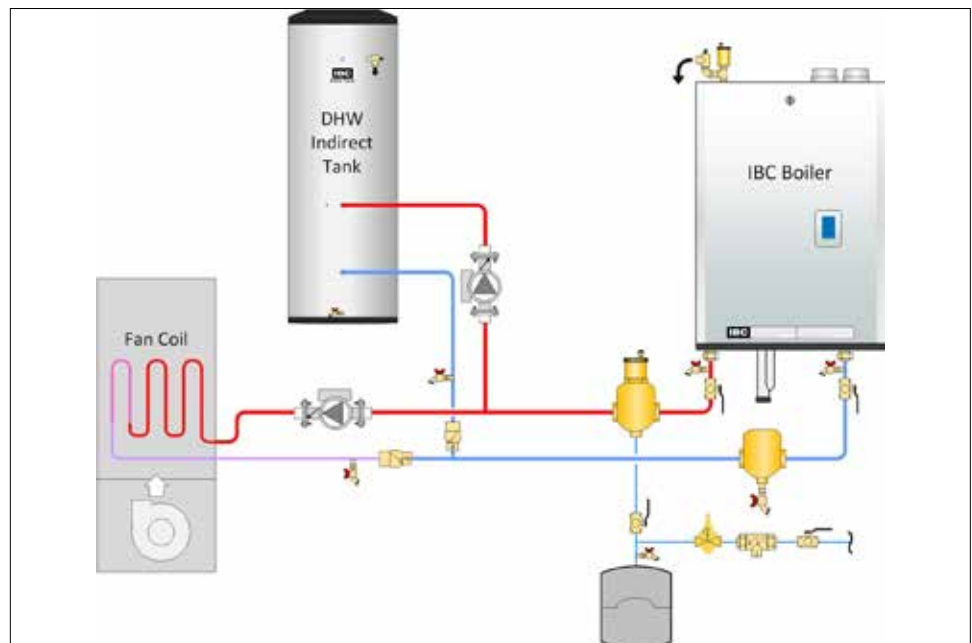

Figure 29: Two pump, two load - parallel piping concept

Compared with the Primary/Secondary approach, the above design saves one pump. Lost is the simplicity of constant head and flow at the boiler.

Check valves or thermal traps should be used to isolate both the supply and return piping for each load - to avoid thermal siphoning and reverse flow.

To ensure adequate water flow through the boiler under high-head / single zone space heating conditions, a pressure activated bypass or other means of bypass must be used on any load where the flow rate might drop below minimum requirements (20 gpm).

For further information and details, consult our Application Notes – which provide detail on specific single and multiple boiler applications “Piping”, “Wiring” and “Settings”. (available at www.ibcboiler.com or from your IBC Representative).

NOTE

The piping drawings in this manual are simple schematic guides to a successful installation. There are many necessary components not shown, and details such as thermal traps are left out so the drawings have greater clarity. We require that our boilers be installed by licensed and experienced trades people who are familiar with the applicable local and national codes. System design is to be completed by an experienced hydronic designer or Engineer. It is necessary to carefully read and follow these installation instructions along with the application drawing that fits your system.

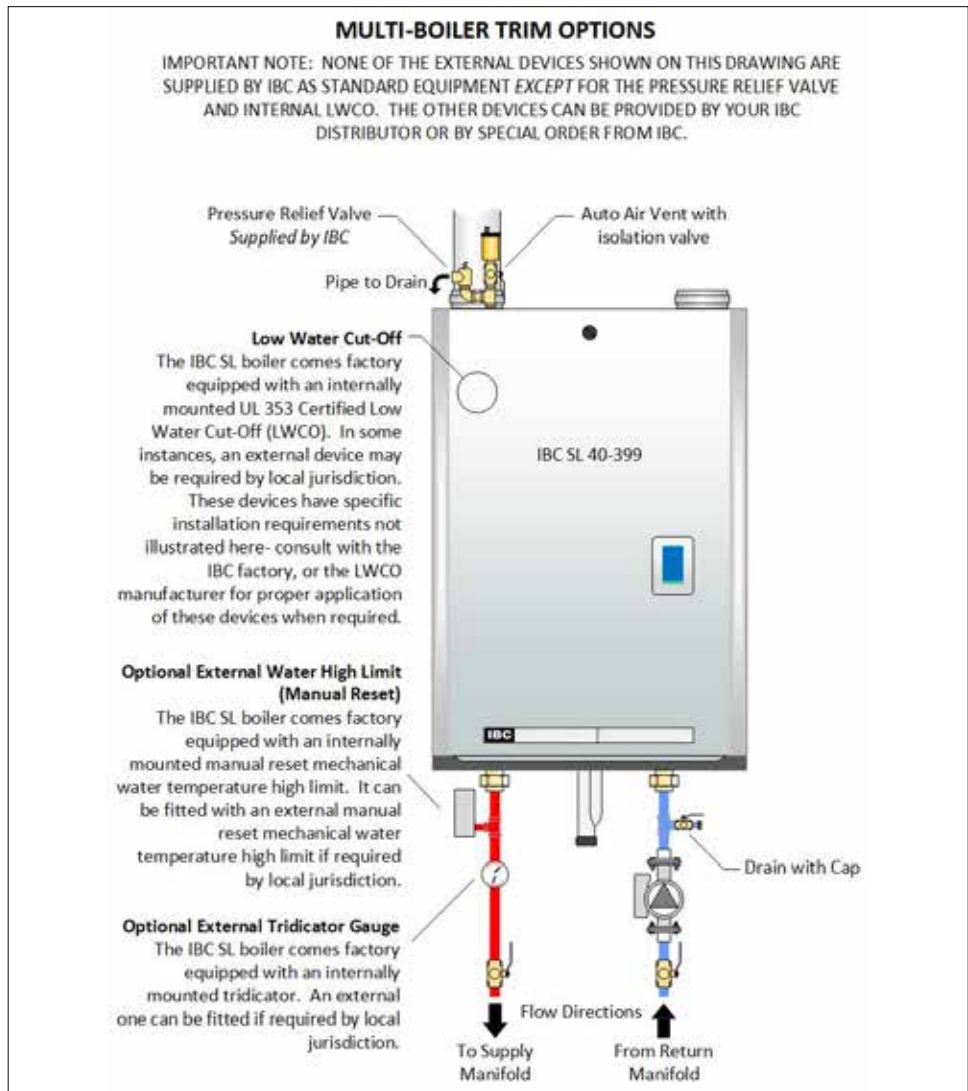

Figure 30: Trim for multiple boiler installations



Figure 31: Multi-Plex Racking System

NOTE

When using the sequential load feature of the IBC boiler, attention must be paid to the operation of system components in order to ensure they are compatible.

Many air handlers (fan coils) for instance have a thermostat connection that will energize an internal relay to operate the air handler circulator and its fan on a call for heat. This may result in operation of these components when other loads are running at a higher priority, resulting in cold air blowing, or robbing heat from another load.

Some wiring alteration may be required to divorce both of these functions from thermostat control in favour of more effective control from the IBC boiler.

NOTE

For further information and details regarding Multiple Boiler application, consult our *Technical Notes - Multiple Boiler Systems*. These notes provide necessary detail on specific single and multiple boiler applications “Piping”, “Wiring” and “Settings”. (available at www.ibcboiler.com or from your IBC Representative).

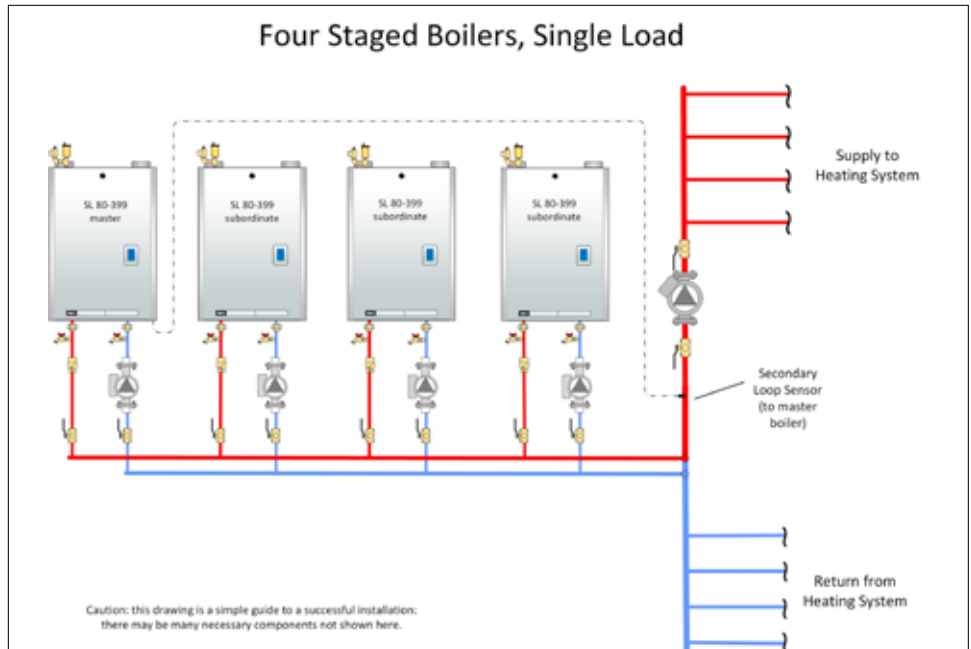

Figure 32: Multiple boiler piping

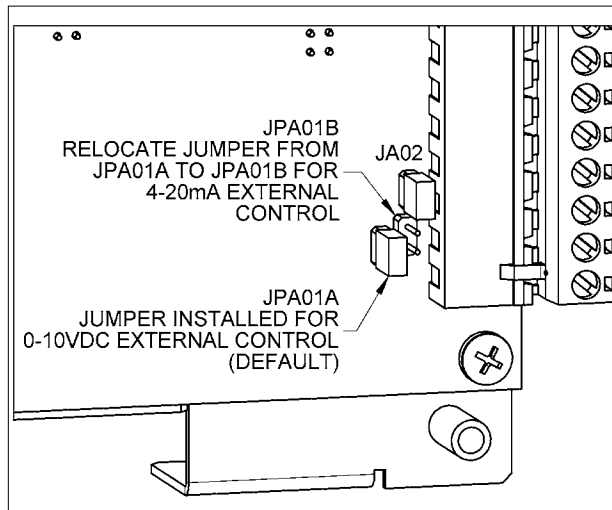

Figure 33: Jumper

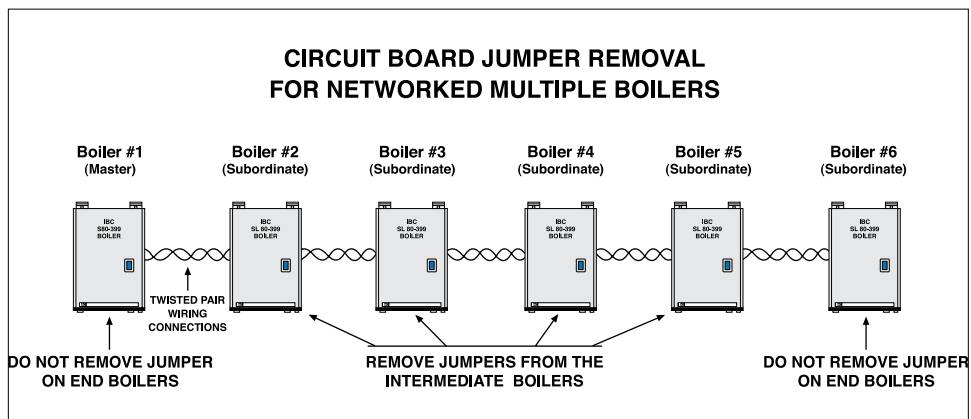

Figure 34: Multiple boiler inter-wiring

NOTE

Due to the precision of modern modulating boilers it is important to pay special attention to gas pressure regulation.

It is essential to check gas supply pressure to each boiler with a manometer or other high-quality precision measuring device. Pressure should be monitored before firing the boiler, when the regulator is in a “lock-up” condition and during operation, throughout the boiler’s full modulation range.

Pay special attention to retrofit situations where existing regulators may have an oversized orifice and/or worn seats, causing pressure “creep” and high lock up pressures.

A high quality regulator will maintain constant pressure above the boiler’s minimum specification at all firing rates, and will not exceed the boiler’s maximum pressure rating when locked-up with no load.

1.7 GAS PIPING

The boilers require an inlet gas supply pressure of at least 4.0" w.c. for natural gas or propane during high fire operation. This will ensure that gas pressure measured at the gas valve inlet pressure tap does not droop below 3.5" w.c. at high fire. For either fuel, the inlet pressure shall be no greater than 14.0" w.c. Confirm this pressure range is available with your local gas supplier.

The inlet gas connection to the boiler is 3/4" NPT (female).

Adequate gas supply piping shall be provided with no smaller than 3/4" Sched 40 (e.g. Iron Pipe Size (IPS) and using a 1" w.c. pressure drop, in accordance with the following chart:

MODEL	3/4" IPS	1" IPS	1 1/4" IPS	1 1/2" IPS
SL 26-260 G3 (Natural Gas)	20'	80'	300'	600'
SL 26-260 G3 (Propane)	70'	200'	800'	1600'
SL 40-399 G3 (Natural Gas)	10'	40'	150'	300'
SL 40-399 G3 (Propane)	30'	100'	400'	900'

Table 6: Maximum Pipe Length (ft)

Gas piping must have a sediment trap ahead of the boiler’s gas valve (see Figure 34). A manual shutoff valve must be located outside the boiler, in accordance with local codes/standards. All threaded joints in gas piping should be made with an approved piping compound resistant to the action of natural gas/propane. Use proper hangers to support gas supply piping as per applicable codes.

The boiler must be disconnected or otherwise isolated from the gas supply during any pressure testing of the system at test pressures in excess of 1/2 psig. Dissipate test pressure prior to reconnecting. The boiler and its gas piping shall be leak tested before being placed into operation.

The gas valve is provided with pressure taps to measure gas pressure upstream (supply pressure) and downstream (manifold pressure) of the gas valve (see Figures 37A and 37B). Note that manifold pressure varies slightly in accordance with firing rates with the modulating series boilers, but will always be close to 0" w.

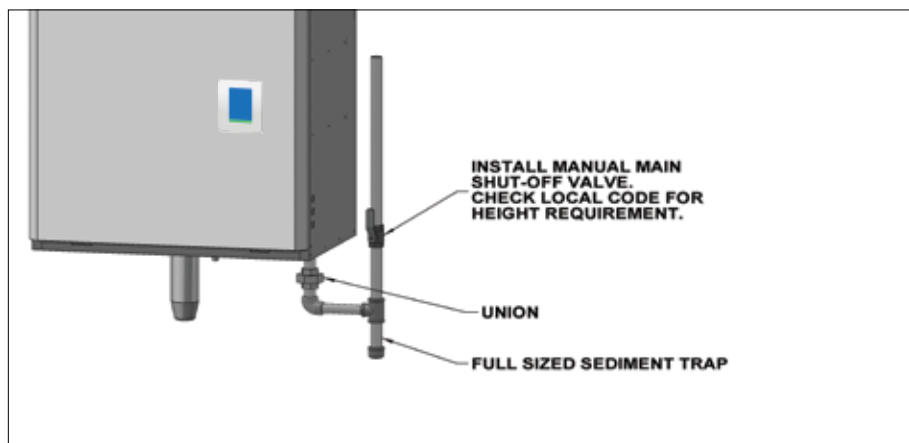

Figure 35: Typical gas piping

1.8 ELECTRICAL CONNECTIONS

All electrical wiring to the boiler (including grounding) must conform to local electrical codes and/or to the National Electrical Code, ANS/NFPA No. 70 – latest edition, or to the Canadian Electrical Code, C22.1 - Part 1.

1.8.1 120 VAC Line Voltage Hook-up

Line-voltage wiring is done within the field-wiring box. (Refer to Section 6.2.Wiring Diagram on page 6-4). Connect the boiler to the grid power using a separate, fused circuit and on/off switch within sight of the boiler. Use 14-gauge wire in BX cable or conduit properly anchored to the boiler case for mains supply and pump circuits.

Connect a 120 VAC / 15 amp supply to the “AC IN” tagged leads in the wiring box. The max. actual draw (with 5 typical residential size pumps) is less than 4 amps.

The 120 VAC power supply to the load pumps (P/V1, P/V2, P/V3, and P/V4) has been factory installed and connected to P/V-L and P/V-N for your convenience. If you use the P/V relay connections for zone valves, then the 120 VAC connections at P/V-L and P/V-N will have to be removed and properly capped off. 24 VAC can then be applied using an external transformer to supply power to zone valves. The upper 4 pairs of contacts on this green connector strip are then powered to manage up to 4 load pumps – the top pair for Load 1, the second pair for #2 etc. Once the controller is programmed for the respective loads, the boiler manages all the loads without need of further relays (for loads up to 1/3 HP; for more – use a protective relay).

The boiler (primary) pump is connected to the White/Yellow pair labeled Primary Pump. This lead is factory wired to the controller (and its 120 VAC supply) at the upper right backside of the controller board. Do not attempt to connect the primary pump to the Pump/ Zone Valve Terminal Block along the controller’s right edge. This is for the secondary pumps and/or zone valves only. Connect the pump’s Black wire to the Yellow of this pair (switched Hot). The White/ Yellow pair should be individually capped if the primary pump does not obtain its power from this pair (e.g. if a variable speed primary pump is connected to the mains power).

Pumps can be switched on/off using the touchscreen controller, so there is no need for temporary pump wiring during system filling / air purging. If pumps are hard-wired to the panel during the system fill/purge phase, re-wire the boiler pump to the primary pump leads inside the wiring box so the primary pump purge function is active.

In a new construction application, use a construction thermostat, or jumper with an in-line on/off switch – for on/off management of the boiler. Do not just pull power from the unit, or its moisture management routine will be interrupted (fan turns at ultra low rpm for 90 minutes after burner shutdown). Treat it like a computer, where you do not just pull the plug when done. If a “low airflow / check vent” error signal shows, check for (and remove) any water in the clear vinyl air reference tubes. This has been seen occasionally at construction sites where the boiler has been repeatedly de-powered wet.

The combined current of all pumps connected through the on-board pump relays should not exceed 10 amps. The control circuit board is protected using on-board field replaceable fuses. Each pump is fused with a separate 5 Amp fuse. The Alarm contact is fused with a 5 Amp fuse and the 24 VAC boiler control circuit is protected with a 2 Amp fuse.



Line voltage leads for power supply, primary pump and VS output



Line voltage load pump terminals

CAUTION

The internal pump relays are protected with 5 Amp fuses. The maximum recommended load on each fuse is 4 Amps (80% of rating). The maximum combined pump load is 10 Amps. Isolation relays or contactors **MUST** be used if the loads exceed these maximums.

NOTE

The IBC boiler (like any modern appliance that contains electronic equipment), must have a “clean” power supply, and is susceptible to power surges and spikes, lightning strikes and other forms of severe electrical “noise”. Power conditioning equipment (surge protectors, APC or UPS devices) may be required in areas where power quality is suspect.

1.8.2 Power Quality and Electrical Protection

In areas of unreliable power, appropriate surge protectors and or power conditioning equipment should be installed in powers supply wiring circuits.

1.8.3 Zone Valve Hook-up

If zone valves rather than pumps are used to manage multiple heating loads, then 24 VAC for the zone valves should be provided to the power contacts on the Pump/ Zone Valve Terminal Block. Disconnect the 120 VAC leads connected to PV-L/PV-N and cap off. Use a separate transformer – the 40 VA unit inside the wiring box is for internal systems only. The individual load/zone valves are then to be wired to their associated contacts on the secondary pump/zone valve connector. Do not confuse such “load/zone valves” with similar valves used to segregate a single load type (e.g. those used on a zoned radiant floor) – see next section.

1.8.4 Thermostat / Sensor Wiring

Dry contacts for thermostats for each of the four loads are provided as marked on the lower connector strip (e.g. “Therm 1”). Gang lines from a multiple-zoned load (e.g. off the end-switches for each radiant floor zone) present a common thermostat signal to the controller. Ensure that there are no disturbing influences on the call-for-heat lines - e.g., that there are no coils to switch an air handler motor. Most power stealing thermostats can be connected directly to the Therm terminals. See the *V-10 Touchscreen Boiler Controller* manual for more detailed instructions.

1.8.5 Other Wiring

Other optional low voltage connections to the control board include:

- Two auxiliary interlocks - for external safety devices as may be required by some jurisdictions, such as a low water cutoff or a low gas pressure cut-out (for off-grid propane). A floor-protecting aquastat (water temperature control) can use one of these, to cause a full boiler shutdown in the case of excess floor temperature.
- Contacts for indoor and outdoor temperatures sensors associated with reset heating. A 10K ohm thermister (resistor dependent on temperature) for outdoor reset sensing is supplied with the boiler for improved comfort and combustion efficiency.
- One pair for a DHW tank sensor. Connect to “DHW S” (not the respective Therm. 1,2,3,4 location) and the boiler automatically detects and calls a smart DHW routine.
- One pair of contacts for remote secondary loop temperature control.
- One pair (marked BoilerNet) for network connection – this is used for connecting multiple SL and/or VFC modulating units for autonomous staging.
- The bottom pair of contacts receives a 0-10VDC (default) or 4-20 mA signal from an external boiler controller for direct throttle control. The boiler’s own sensors act as high limits only. The user must enter maximum and minimum boiler supply temperatures.

NOTE: Sensors connected to any sensor input contacts must be of the NTC Thermister type with a resistance of 10,000 ohms at 77°F (25°C) and $\beta = 3892$. We do not recommend using 3rd party supplied sensors. Compatible water temperature sensors and outdoor sensors can be supplied by your IBC distributor.

DANGER

Do not connect thermistor sensors to “Therm” terminals. An overheating hazard can result in serious personal injury and/or property damage. See *Controller Manual section 2.1.1 for detailed instructions.*

NOTE

The IBC Touch-Screen controller has the ability to connect to most power stealing thermostats. See the *V-10 Touchscreen Boiler Controller* manual for details.

1.8.6 Thermostat Heat Anticipator

IBC “Therm.” contacts draw no power, so an anticipator setting for the thermostat is not applicable with the SL modulating series boilers. In the case of a single temperature / heat load where zone valves are used to manage individual thermostatically controlled zones, each room thermostat’s heat anticipator should be adjusted to the current draw of its associated zone valve.

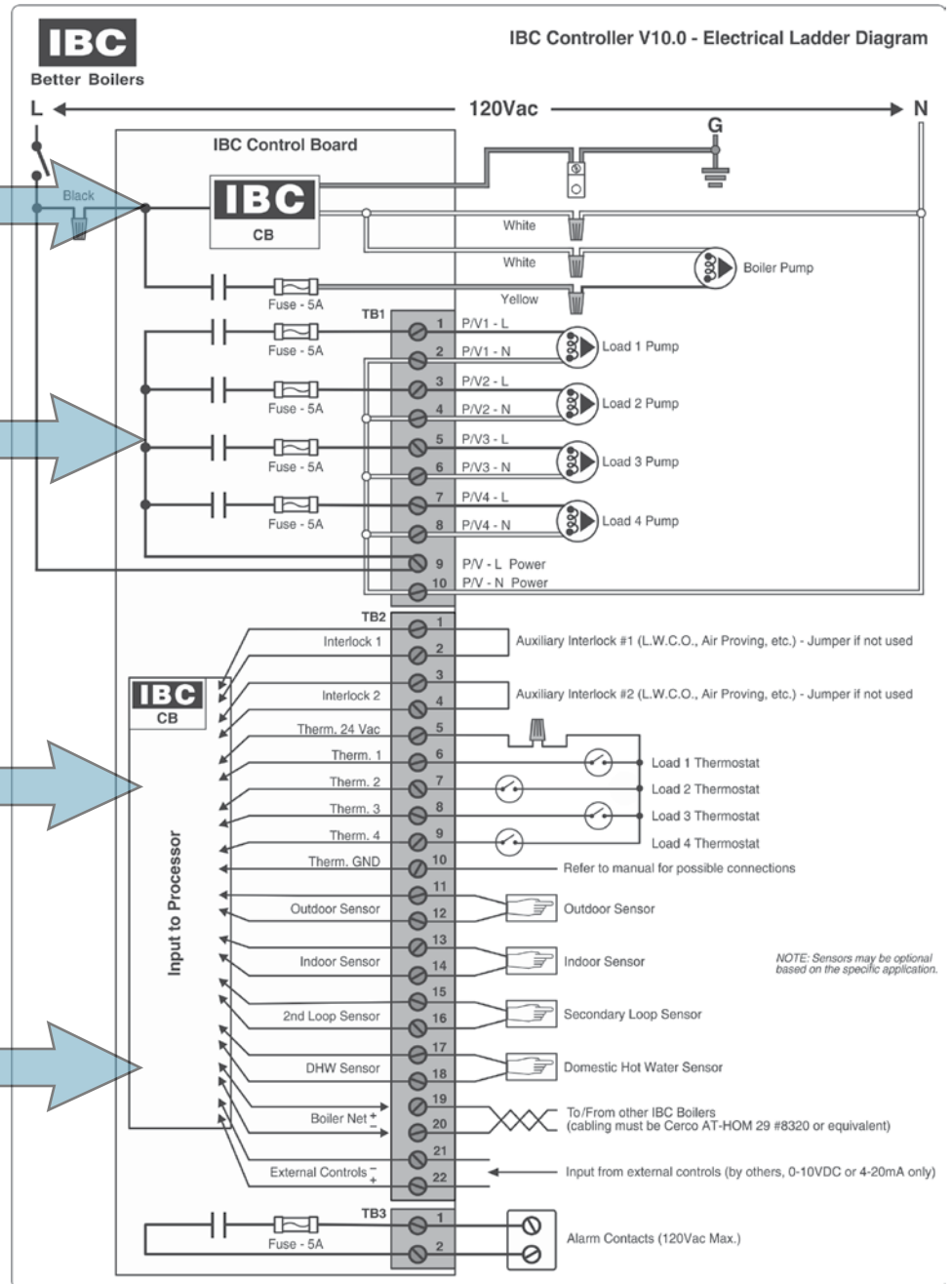
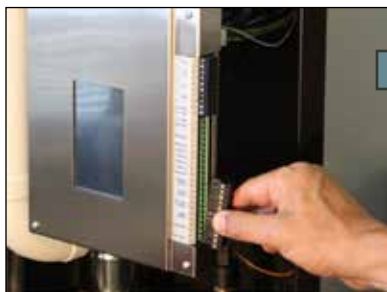
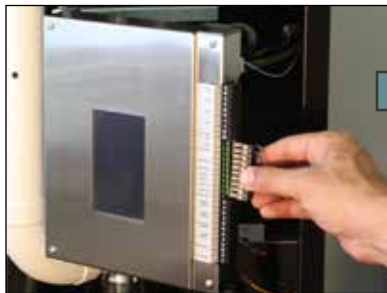
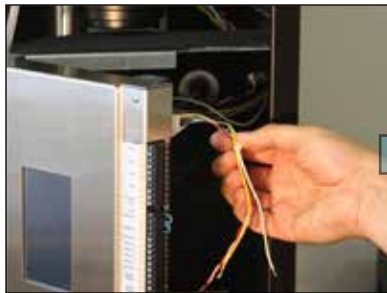

Figure 36 : Electric wiring connections (full-page wiring diagram on the back of this manual)

THIS PAGE IS INTENTIONALLY LEFT BLANK.



2.0 IBC BOILER CONTROLLER

2.1 GENERAL

This boiler is equipped with the V-10 Touchscreen controller. The controller simplifies the programming of the boiler while providing greater flexibility. For more detailed instructions, reference the Touchscreen Boiler Controller manual.

The controller is equipped to provide:

- Control of up to 5 pumps – 1 boiler pump + 4 separate load pumps
- Outdoor Reset control
- Set Point temperature regulation
- Domestic Hot Water (DHW)
- External control via 0-10VDC or 4-20mA signaling
- Alarm dry contacts
- Load Combining – simultaneous operation of 2 similar water temperature loads
- The control can manage and/or operate in a network of up to 24 IBC VFC or SL boilers

Some of the new features available in the touchscreen control include:

- Express Setup Menu for simple, quick programming
- Software updatable in the field with an SD card or a USB stick
- Setup configuration back-up and cloning using an SD card or USB stick
- Superior warning messages while setting up the control
- Advanced Error messages with visual display on the Home Screen
- Internet/LAN connectivity
- BACnet (with activation)

2.2 CONTROL

When the boiler is first energized, the controller will go through a power up sequence that will take approximately 90 seconds. During this time the controller is completing a self-diagnostic and loading all previous settings. In the event of a power interruption the boiler will automatically resume operation when power is restored with all the previously stored values. The controller provides overall management of the boiler operations including:

- Power-up, Self-diagnostics, easy Load parameter adjustments
- Burner operation, safety management systems, Call for Heat management and Load Priority
- Real time boiler data
- Temperature and throttle operation
- Maintenance of operational and error service logs
- 2-way communication between other IBC boilers and controls

Operational and historical data may be accessed at any time using the System Status and Load Profiles sections of the control. Error logs are available in the Diagnostics section and the controller is capable of recording any or all errors since original power-up complete with the date and time of the error.

NOTE

No sharp or metallic object should be used on the touchscreen as this will cause damage. Use only a Stylus or a clean finger.”



2.3 CONTROL INTERFACE

The control interface is provided through a 2-1/4 x 4 inch, color touchscreen display. The touchscreen responds to a light finger touch on the screen. You can also use a stylus or similar device to operate the touch controls. Do not use a sharp or metallic object such as a screw driver to operate the control as it could damage the touchscreen.

The controller display is divided into two areas, the screen active area and the boiler status bar. All screens have an active area consisting of the screen title bar at the top and a border surrounding the active area. At the bottom of the display there is space reserved for the boiler status bar.

Prior to any interaction with the touchscreen, the display shows the Home screen details of the current boiler status. If the controller has been left on the Home screen long enough (user adjustable, 10 minutes by default) the display will be dimmed to save power.

The control will automatically return to the home screen if left unattended. The screens will step back one screen at a time in 10 minute increments if the touchscreen has not been touched. The pop-up windows will also step back automatically in 2 minute intervals.

The boiler status bar indicates if the boiler is in a normal, warning or alarm state. When no warning or alarm state is present, the bar will be green and the time will be displayed inside the green area. The bar can also be yellow or red corresponding a warning or alarm state. Text inside the bar will indicate the specific warning or alarm present. If more than one alarm is present the text display will slowly change, rotating through whatever alarms that are present.

3.0 STARTUP & COMMISSIONING

3.1 BOILER SHUTDOWN & LIGHTING

FOR YOUR SAFETY READ BEFORE OPERATING

WARNING: If you do not follow these instructions exactly, a fire or explosion may result causing property damage, personal injury or loss of life.

- A. This appliance does not have a pilot. It is equipped with an ignition device which automatically lights the burner. Do not try to light the burner by hand.
- B. BEFORE OPERATING smell all around the appliance area for gas. Be sure to smell next to the floor because some gas is heavier than air and will settle on the floor.
WHAT TO DO IF YOU SMELL GAS
 - Do not try to light any appliance.
 - Do not touch any electric switch; do not use any phone in your building.
 - Immediately call your gas supplier from a neighbor's phone. Follow the gas supplier's instructions.
- C. If you cannot reach your gas supplier, call the fire department.
- C. Use only your hand to turn the gas control valve. Never force using tools. If the valve will not turn by hand, don't try to repair it, call a qualified service technician. Force or attempted repair may result in a fire or explosion.
- D. Do not use this appliance if any part has been under water. Immediately call a qualified service technician to inspect the appliance and to replace any part of the control system and any gas control which has been under water.

OPERATING INSTRUCTIONS

1. STOP! Read the safety information above on this label before doing anything.
2. Set the thermostat to lowest setting.
3. Turn off all electric power to the appliance by selecting main power switch to OFF.
4. This appliance is equipped with an ignition device which automatically lights the burner. Do not try to light the burner by hand.
5. Locate manual gas shut-off valve (see pictures below) and turn clockwise to "CLOSE".
6. Wait five (5) minutes to clear out any gas. Then smell for gas, including near the floor. If you smell gas, STOP! Follow step "B" in the safety information above on this label. If you don't smell gas, go to the next step.
7. Turn gas control valve to OPEN.
8. Turn on electric power to appliance by selecting main power switch to ON.
9. Set thermostat to desired setting.
10. If the appliance will not operate, follow the instructions "TO TURN OFF GAS APPLIANCE" and call your service technician or gas supplier.

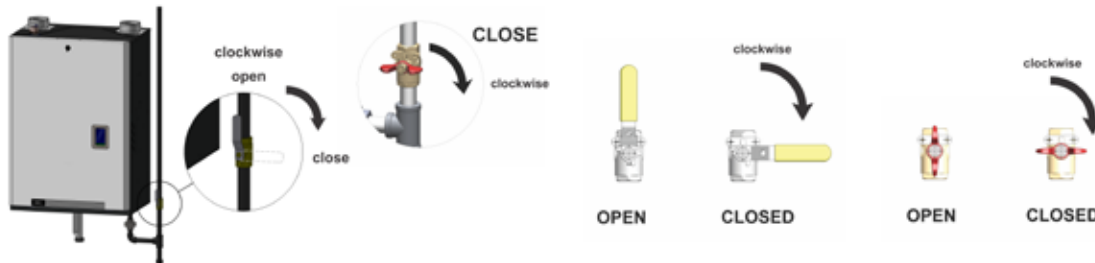

TO TURN OFF GAS APPLIANCE

1. Set the thermostat to lowest setting.
2. Turn off all electric power to the appliance by selecting main power switch to OFF.
3. Turn gas control valve to CLOSE.

⚠ WARNING

Fill trap with water before boiler is first fired to prevent exhaust fumes from entering room. Never operate the boiler unless the trap is filled with water. Failure to comply will result in severe personal injury or death.



Error displayed after testing ignition safety shut off

3.2 PRIOR TO START-UP

3.2.1 Pre-Ignition Checks

1. Ensure venting system is complete and seal tested. Confirm any common venting system at the installation site is isolated and independent of the SL boiler. Also confirm that any holes left from the removal of a previous boiler have been sealed, and that any resizing of the old flue has been done. Fill condensation trap.
2. Check that the water piping system is fully flushed and charged, and that all air has been discharged through loosened bleed caps. Note it is possible to switch all pumps on/off from the touchscreen – without a call for heat. This greatly simplifies system filling and air bleeding (go to Installer Setup, System Settings, Site Settings, change Manual Pump Purge to “ON”. When complete, return to Off, or this will automatically occur with a call for heat). Use a minimum water pressure of 12 psig. And confirm that the pressure relief valve is installed and safely drained.
3. Check to see that adequate gas pressure is present at the inlet gas supply test port. Open the test port by turning its center-screw one full turn counterclockwise, using a small (1/8” or 3 mm) flat screwdriver.. Connect a manometer and open the gas control valve. Requirements are minimum 5” w.c and maximum 14” w.c. Check that there are no gas leaks.
4. Perform a final check of electrical wiring, and provide power to the boiler to initialize operation.

3.2.2 Test Ignition Safety Shutoff

With the boiler in operation, test the ignition system safety shutoff device by shutting the gas control valve immediately outside the boiler case. Ensure the boiler has shut off and the appropriate Error information is displayed on the Touchscreen. To restart the boiler, reset power or press “Clear Errors” in the Advanced Diagnostics section.

3.3 COMMISSIONING

The SL boilers are factory calibrated to operate with natural gas (or propane if so ordered) at sea level. The Low Fire (Zero Offset) valve adjustment cap has been factory sealed using paint-seal compound. **This cap must not be tampered with. The Low Fire (Zero Offset) screw is not to be adjusted in the field.** The High Fire (Gas:Air ratio) adjustment screw may have to be adjusted to attain optimum combustion results if required, however, no mixture adjustment shall be performed unless done by a qualified technician using properly functioning and calibrated combustion analyzing equipment.

The controller will automatically detect the installation's altitude and make the appropriate adjustments to operate the boiler up to 12,000 feet in elevation without de-ration. The boiler will automatically de-rate at altitudes above 12,000 feet. Refer to the IBC Altitude tables for further information.

⚠ DANGER

Making adjustments to the IBC gas valve without a properly calibrated gas combustion analyzer and by persons who are not trained and experienced in its use is forbidden. Failure to use an analyzer can result in an immediate hazard.

1. Turn off the gas supply. With a small (1/8" or 3 mm) flat screwdriver, open the inlet gas supply pressure test port by turning its center-screw one full turn counterclockwise. Attach a manometer to the pressure test port, and turn on the gas to the appliance. The static manometer reading should be ideally 7" w.c. for Natural Gas and 11" w.c. for Propane. Minimum and maximum static pressure should be between 4" and 14" w.c. Monitor pressure throughout the commissioning procedure. Pressure may drop up to 1" to 2" w.c. at high fire but under no circumstances should it drop below 4" w.c. at the gas valve inlet test port.
2. Allow the boiler to ignite. Run against a large load, to maintain high fire.
3. With a combustion analyzer probe in the flue gas test port, turn the High Fire (Gas:Air Ratio) Adjustment screw (see Figure 37A and Figure 37B) (see Table 7 below for the corresponding CO₂ values - set the CO₂ target at high fire). This screw offers very fine adjustment, and may require several turns.

NOTE: This screw has significant backlash. When changing direction of turn, it may take up to a full turn before any change is indicated on the analyzer reading. Clock the gas meter to confirm full maximum rating plate input.

4. Confirm the minimum fire level settings. Re-define the load as "Manual Control". Use Heat Output in "Configure Load x" to control the output as needed. The reading should be within the Low fire range. Re-test at high fire.
5. Turn boiler off by removing the call for heat (use the Installer Setup screen to turn load to off if no other ready means available). Turn off gas then remove the manometer connections, and turn the centre-screw in the manifold pressure test port clockwise until fully closed. Ensure fully closed, but not over-tightened. Restore gas and soap test for leaks.

MODEL	HIGH FIRE		LOW FIRE		CO MAX PPM
	RANGE	TARGET	RANGE	TARGET	
Natural Gas	9.0 – 10.0	9.5	8.2 – 9.2	8.7	< 150
Propane	10.3 – 11.3	10.8	9.3 – 10.3	9.8	< 250

Note: Low Fire CO₂ should be at least 0.5% lower than High Fire CO₂

Table 7: Combustion test target ranges - CO₂ / Maximum CO

3.3.1 Gas Valve and Fan Diagrams

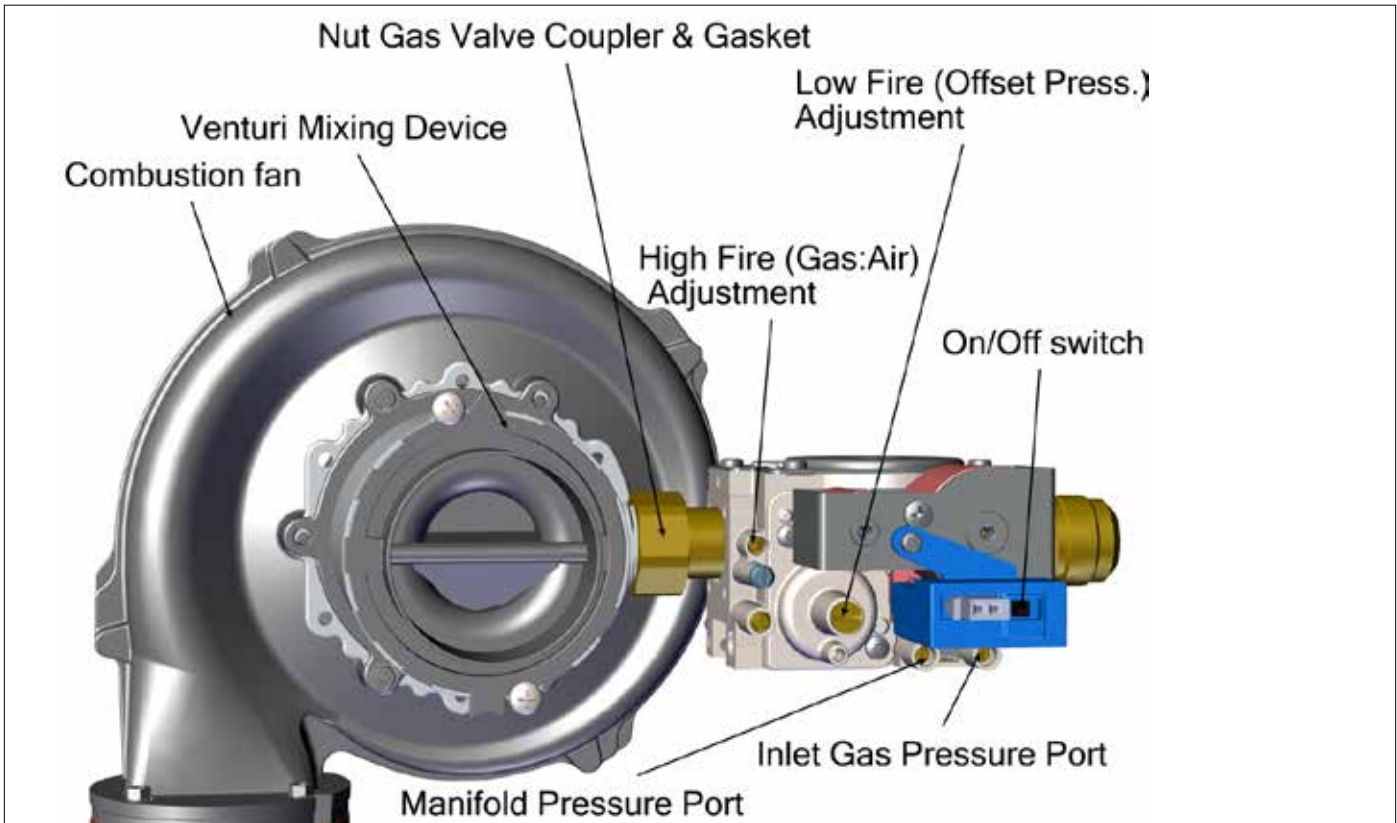

Figure 37A: Gas Valve and Pressure Reference System - SL 26-260 G3

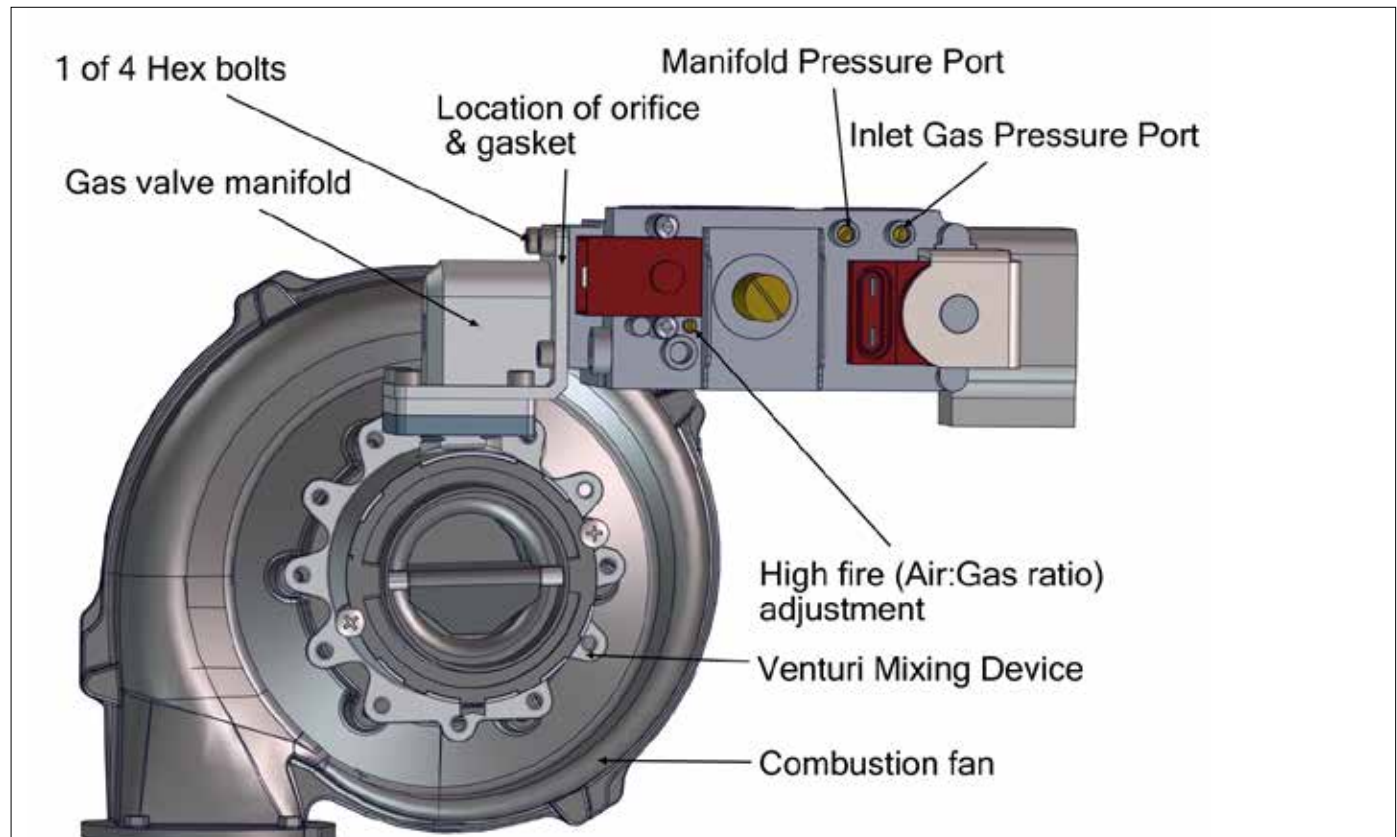

Figure 37B: Gas Valve and Pressure Reference System - SL 40-399 G3

⚠ WARNING

Check the rating plate of the boiler to ensure it is configured for the fuel you are using. If the fuel is incorrect for the appliance, a conversion kit must be ordered from IBC and the gas valve adjusted accordingly. Failure to perform the required fuel conversion can result in an immediate hazard.

⚠ DANGER

Operating any IBC boiler using a fuel other than the fuel listed on its rating plate is prohibited. If the information in this section related to conversion to alternate fuels is not followed exactly, a dangerous situation can result, leading to fire or explosion, which may cause property damage, personal injury, or loss of life.

3.4 FUEL CONVERSION

The SL boilers are factory fire-tested to operate with natural gas or propane as ordered. The rating plate will be marked to indicate which fuel the particular boiler has been set up with. Firing a boiler with a fuel other than what is listed on the rating plate is prohibited unless the following conversion procedure is completed by a qualified technician.

Refer to the previous section 3.3 - COMMISSIONING. The Low Fire (Zero offset) valve adjustment cap on the gas valve has been factory sealed using paint-seal compound. This cap must not be tampered with. The Low Fire (Zero offset) screw is not to be adjusted in the field.

The High Fire (Gas:Air ratio) adjustment screw will have to be adjusted to attain optimum combustion results whenever fuel conversion is undertaken, however, no mixture adjustment shall be performed unless done by a qualified technician using properly functioning and calibrated combustion analyzing equipment.

Fuel conversions must be carried out by a qualified technician:

1. Ensure you are installing the correct fuel conversion kit for your boiler. Compare the boiler model number with the Kit # found in Table 8.
2. Read the fuel conversion instructions supplied with the fuel conversion kit.
3. Carefully follow the procedures of the fuel conversion instructions on:
 - Fuel Conversion
 - Combustion Testing and Adjustment
 - Placing conversion labels associated with the new fuel onto the boiler.
4. Carefully follow the “Prior to Start-Up” – Section 3.2 and “Commissioning” – Section 3.3 procedures on the preceding pages 3-2 and 3-3.

Fuel Conversion Kit Part Numbers

MODEL NUMBER	NATURAL GAS TO PROPANE	PROPANE TO NATURAL GAS
SL 26-260 G3	P-300	P-301
SL 40-399 G3	P-302B	P-303B

Table 8: Fuel Conversion Kits

NOTE

The safety warning regarding burner refractory on page 4-2 of this manual must be observed.



Heat Exchanger Lid removed



Refractory removed



Burner and Heat Exchanger Lid

3.4.1 Gaining access to combustion chamber and burner removal instructions

SL 26-260 G3

1. Remove the fan and gas valve assembly. See "Fan and gas valve removal instructions" on page 4-6 of this manual.
2. Disconnect the igniter cable, gas valve cable and the two fan plugs, and move them out of the way.
3. Remove the two screws that secure the igniter to the lid using a # 2 Phillips screwdriver.
4. Carefully remove the igniter by sliding it straight up.
5. Remove the igniter gasket, and place the parts on a clean dry area.
6. Remove the 8 hex nuts that attach the heat exchanger lid to the heat exchanger with a 10 mm open-end wrench or socket.
7. With a permanent marker or equivalent, make an alignment mark between the lid, gasket, and heat exchanger.
8. Before removing the lid, it is important to be positioned directly above it to ensure a straight-up extraction. Failing to do this may result in refractory damage.
9. Slowly lift the lid-burner assembly off the heat exchanger. The refractory should remain in place in the combustion chamber shoulder. Note that there is less than 1/8" (3 mm) clearance between the burner walls and the refractory. Care must be observed to ensure minimal contact between these parts to prevent refractory cracking.
10. Place the lid with the burner attached, on a clean dry area.
11. With a permanent marker or equivalent, make an alignment mark on the refractory, lining it up with the same mark made earlier between the lid and heat exchanger.
12. Carefully remove the refractory, and place it in a clean dry area.
13. If the burner needs to be removed, gradually loosen the five screws that secure the burner to the heat exchanger lid with a # 2 Phillips screwdriver. Then remove the screws and the burner.

SL 40-399 G3

1. Remove the fan and the gas valve assembly. See "Fan and gas valve removal instructions" on page 4-6 of this manual.
2. Disconnect the igniter cable, and move it out of the way.
3. Remove the two screws that secure the igniter to the lid with a # 2 Phillips screwdriver.
4. Carefully remove the igniter by sliding it straight up.
5. Remove the igniter gasket, and place the parts on a clean dry area.
6. Loosen the lid fasteners located around the top edge of the heat exchanger, and swing the bolts off the lid and let them hang down.
7. With a permanent marker or equivalent, make an alignment mark between the lid and heat exchanger.
8. Before removing the lid, it is important to be positioned directly above it to ensure a straight-up extraction. Failing to do this may result in refractory damage.
9. Carefully lift the lid-burner assembly straight up and out of the heat exchanger, being careful not to damage the refractory.
10. Place the lid with the burner attached, on a clean dry area.

11. With a permanent marker or equivalent, make an alignment mark on the refractory, lining it up with the same mark made earlier between the lid and heat exchanger.
12. Carefully remove the refractory, and place in a clean dry area.
13. If the burner needs to be removed, gradually loosen the screws that secure the burner to the heat exchanger lid with an M5 hex screwdriver. Then, remove the screws and the burner.

Re-assembly

SL 26-260 G3

1. Inspect the burner gasket: look for cracks, deterioration or signs of gas bypass. Replace if necessary.
2. Place the heat exchanger lid on a flat surface, and position the gasket on the lid, aligning it with the screw holes.
3. Install the burner in place with its four screws, tightening the screws gradually and in a cross sequence. Do not over tighten; tighten by hand plus an 1/8 of a turn to maintain a good seal and to prevent deformation of the burner flange.
4. Inspect the refractory for cracks, degradation and flatness. If in doubt, replace with a new one.
5. If installing a new refractory, first place it onto the lid, aligning it at the igniter hole, then make an alignment mark on the refractory to correspond with the previously made line on the lid.
6. Carefully insert the refractory into the heat exchanger combustion chamber, using the alignment marks for proper positioning.
7. Ensure that the lid gasket is in good condition, and is in place and level.
8. Carefully insert the lid-burner assembly straight down. Ensure that there is limited contact between the burner and the refractory as well as observe the alignment markings.
9. Install the 8 hex nuts to secure the lid in place; tighten by hand plus an extra 1/2 to 1 turn. Caution! Over-tightening these nuts will cause the lid to warp and possibly leak fumes or flames.
10. Re-install the igniter, tightening its screws by hand plus an extra 1/8 of a turn.
11. Re-attach the igniter wire to the igniter, gas valve cable and the two fan plugs.

SL 40-399 G3

1. Inspect the burner gasket: look for cracks, deterioration or signs of gas bypass. Replace if necessary.
2. Place the heat exchanger lid on a flat surface and position the gasket on the lid, aligning it with the screw holes.
3. Install the burner in place with its screws, tightening the screws gradually and in a cross sequence. Do not over tighten; tighten by hand plus a 1/2 turn to maintain a good seal and prevent deformation of the burner flange.
4. Inspect the refractory for cracks, degradation and flatness. If in doubt, replace with a new one.
5. If installing a new refractory, first place it onto the lid, aligning it at the igniter hole, then make an alignment mark on the refractory to correspond with the previously made marking on the lid.
6. Carefully insert the refractory onto the heat exchanger combustion chamber, using the alignment marks for proper positioning.

7. Ensure that the lid (orange) gasket is in place and level.
8. Carefully insert the lid-burner assembly straight down. Ensure that there is limited contact between the burner and refractory, and observe the alignment markings.
9. Swing up the lid fasteners, ensuring the nuts and the washers are above the lid. Evenly tighten the nuts in a cross pattern, and ensure that the lid is securely tightened. Test for leaks around the gasket seal to ensure there are no flue gas leaks.
10. Re-install the igniter, tightening its screws by hand plus an extra 1/2 a turn.
11. Re-attach the igniter wire to the igniter.

4.0 MAINTENANCE

4.1 BOILER MAINTENANCE

CAUTION

The owner is responsible for general care of the boiler. Improper maintenance of the boiler may result in a hazardous condition.

CAUTION

Label all wires prior to disconnection when servicing controls. Wiring errors can cause improper and dangerous operation.

WARNING

Fill trap with water before boiler is first fired to prevent exhaust fumes from entering room. Never operate the boiler unless the trap is filled with water.

Failure to comply will result in severe personal injury or death.

WARNING

Whenever the burner is removed for inspection or boiler servicing, the sealing gaskets must be examined and replaced if damaged. Upon re-assembly, an approved leak test solution must be applied around the burner flange sealing area to ensure there is no leakage of combustible gas/air premix.

4.1.1 General Care

- Keep combustible materials and flammable liquids and vapors away from the boiler.
- Keep vent terminals clear of obstructions (snow, dirt, etc.).

4.1.2 Inspection

Inspection of the boiler is to be performed annually by a qualified service technician.

4.1.3 Venting

- Remove any obstructions to vent terminals (e.g. leaves, dust, other debris).
- Clean or replace intake air filters or screens as required.
- Check for holes or leaks in venting. Replace venting as needed.
- Examine for any signs of moisture caused by sweating intake air pipes; insulate as required.
- Ensure proper resealing or reinstallation of venting on each servicing.

4.1.4 Condensate Traps

- The condensate trap must be examined every two months to see if cleaning is necessary (refer to trap cleaning instructions, section 1.5.3 of this manual). Ensure that the trap has been re-filled completely before firing boiler.
- If condensate neutralization is used, check the pH level of condensate discharge.

4.1.5 Burner

- Annually, remove the burner to inspect for fouling (refer to the burner removal and reassembly instructions, section 3.4.1 of this manual). Blow clear using compressed air. Evaluate the magnitude of clearing required, and establish a reasonable burner inspection schedule. Some boiler / locations may call for annual service, others showing clean burners will only need attention every 2 – 5 years. Consider adding air filtration if the burner requires cleaning every year. In alternate years, visually inspect the burner through the sight glass. Ensure that the flame is stable and is without excessive fluttering. Normal flame pattern is evenly distributed over the burner surface.
- If the burner is operating improperly, remove and clean or replace. Use a CO₂ analyzer to determine proper combustion. See Table 7 for correct values.

4.1.6 Heat Exchanger

During annual inspection (with the burner removed), examine the heat exchanger for signs of contamination and clean if necessary. In areas of poor gas quality, there may be a buildup of black plaque (typically sulfur). Other fouling agents may include: airborne dust, debris and volatiles.

Refer to the burner removal instructions in Section 3.4.1 for access to combustion chamber and heat exchanger. Note that the safety warning regarding burner refractory on this page must be observed.

⚠ WARNING

The IBC heat exchanger has a small amount of combustion chamber insulation (refractory), which contains ceramic fibers.

When exposed to extremely high temperatures, the ceramic fibers, which contain crystalline silica, can be converted into cristobalite - which is classified as a possible human carcinogen.

Care should be taken to avoid disturbing or damaging the refractory. If damage occurs, contact the factory for directions.

Avoid breathing and contact with skin and eyes and follow these precautions:

1. For conditions of frequent use or heavy exposure, respirator protection is required. Refer to the "NIOSH Guide to the Selection and Use of Particulate Respirators Certified under 42 CFR 84" for selection and use of respirators certified by NIOSH. For the most current information, NIOSH can be contacted at 1-800-356-4676 or on the web at www.cdc.gov/niosh.

2. Wear long sleeved, loose fitting clothing, gloves and eyes protection.

3. Assure adequate ventilation.

4. Wash with soap and water after contact.

5. Wash potentially contaminated clothes separately from other laundry and rinse washing machine thoroughly.

6. Discard used insulation in an air tight plastic bag.

NIOSH stated first aid:
Eye contact - Irrigate and wash immediately.
Breathing - Provide fresh air.

4.1.7 Pump

Check that the pump is on in normal operation and that the water ΔT is reasonable for a given firing rate.

4.1.8 Gas Piping

Check for damage or leaks and repair as needed.

4.1.9 Touchscreen Boiler Controller

- Check that the boiler operation is consistent with the steps in the Touchscreen Boiler Controller manual.
- Check that the water temperature targets and setpoint are satisfactory and that they have not been adversely amended.
- Check the operating history via the boilers Logs menu and the Error Logs menu. The controller tracks the duty cycle of the boiler in each of the four loads separately. This information can be used to adjust the water temperatures of each load.
- If a problem exists with the control, consult the Troubleshooting section.

4.1.10 Water

- Check the water pressure and temperature. There should be no noticeable change if the boiler is functioning normally. Check for any noise in the system.
- Check the water piping for damage or leaks. Repair as needed.
- Check for 12-15 psig in normal operation, and look to ensure pressure does not run up toward 30 psig at high temperature. If pressure rises sharply, consider replacement of the expansion tank. Check also for noise at high fire, which may signal water quality problems.
- Water chemistry shall be of a quality generally accepted as suitable for hydronic applications.
- Ensure any direct "city fill" water connections are left in the closed position to minimize exposure to leaks and flooding.

4.1.11 Freeze Protection

Check the freeze protection. Use only antifreeze made specifically for hydronic systems. Inhibited propylene glycol is recommended. Antifreeze volume must be between 25% and 50% of the total volume of water in the system.

4.1.12 Boiler Treatment

- Check consistency of any boiler treatment used, for appropriate mixture. Chemical inhibitors are consumed over time, lowering their density.
- Verify proper operation after servicing.

⚠ WARNING

Do not use automotive-type ethylene or other types of automotive glycol antifreeze, or undiluted antifreeze of any kind. This may result in severe boiler damage. It is the responsibility of the Installer to ensure that glycol solutions are formulated to inhibit corrosion in hydronic heating systems of mixed materials. Improper mixtures and chemical additives may cause damage to ferrous and non-ferrous components as well as non-metallic, wetted components, normally found in hydronic systems. Ethylene glycol is toxic, and may be prohibited for use by codes applicable to your installation location. For environmental and toxicity reasons, IBC recommends only using non-toxic propylene glycol.

⚠ CAUTION

Installers should inquire of local water purveyors as to the suitability of their supply for use in hydronic heating systems.

If water quality is questionable, a local water treatment expert must be consulted for testing, assessment and, if required, treatment.

Alternatively, water or hydronic fluid of known quality can be brought to the site.

⚠ CAUTION

Before testing the relief valve, make certain the discharge pipe is properly connected to the valve outlet and arranged to contain and safely dispose of equipment discharge.

4.1.13 Relief Valve - Maintenance and Testing

The relief valve manufacturer requires that under normal operating conditions a “try lever test” must be performed every two months. Under severe service conditions, or if corrosion and/or deposits are noticed within the valve body, testing must be performed more often. A “try lever test” must also be performed at the end of any non-service period.

Test at or near the maximum operating pressure by holding the test lever fully open for at least 5 seconds to flush the valve seat free of sediment and debris. Then release the lever and permit the valve to snap shut.

If the lever does not activate, or there is no evidence of discharge, discontinue use of equipment immediately and contact a licensed contractor or qualified service personnel.

If the relief valve does not completely seal, and fluid continues to leak from the discharge pipe - perform the test again to try and flush any debris that may be lodged in the valve. If repeated tries fail to stop the leakage, contact a licensed contractor or qualified service personnel to replace the valve.

While performing a “try lever test”, a quantity of heat transfer fluid will be discharged from the piping system and the system pressure will drop. This fluid must be replaced. It is highly recommended that a system pressurization unit, such as an Axiom Industries model MF200 be employed to refill and pressurize your system. Capture the discharged fluid in a container and recycle it by returning it to the system feeder unit. This is particularly important when your system contains treatment chemicals or glycol solutions. If the system employs plain water, the boiler auto fill valve must be turned on in order to recharge the lost fluid.

4.2 GEOGRAPHY & COMPONENTS

Components of the SL 26-260 G3

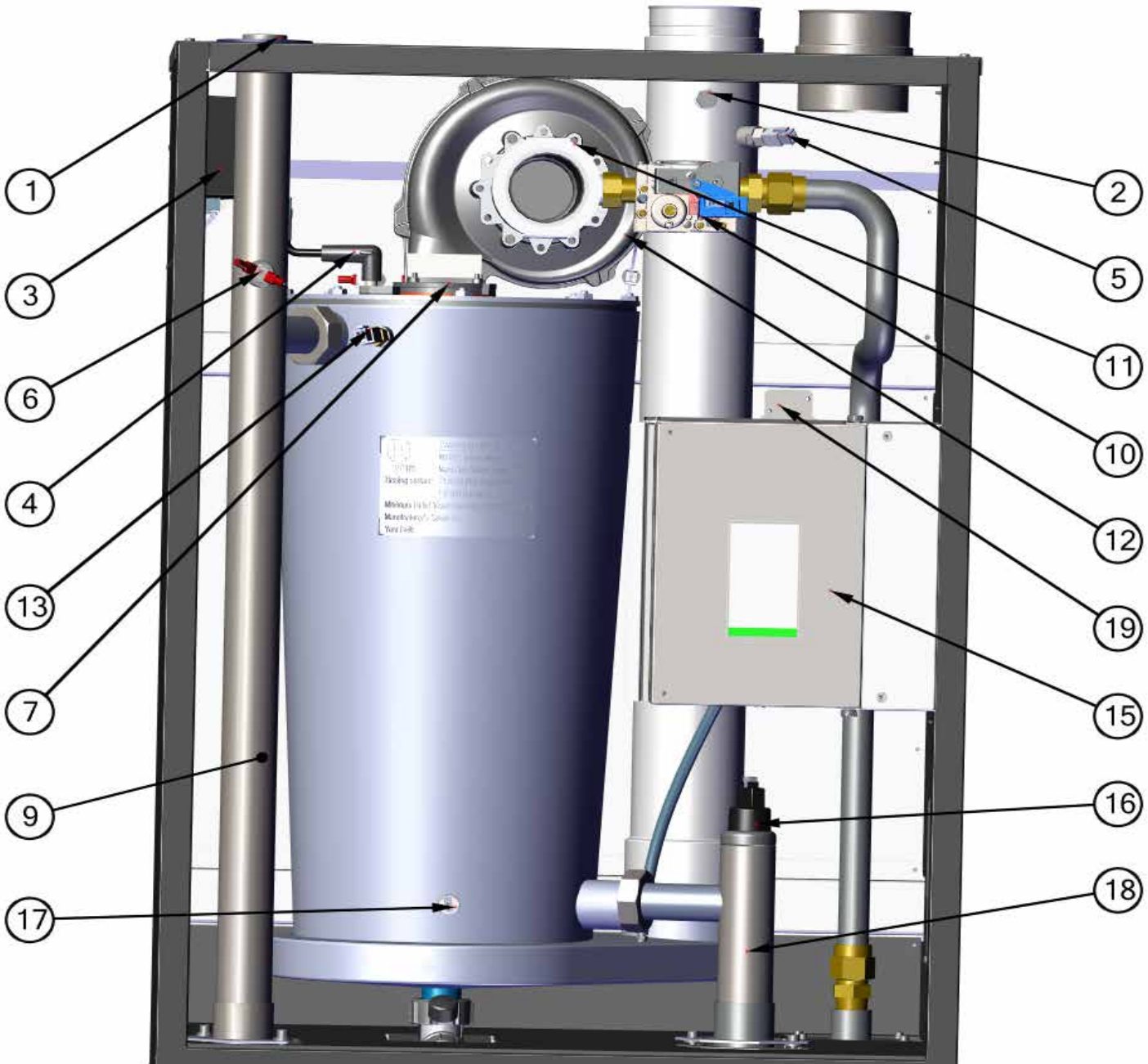

ITEM NO.	COMPONENT	ITEM NO.	COMPONENT
1	Pressure Relief Valve	6	Low Water Cutoff Probe
2	Combustion Test Port	7	Site Glass
3	Safety Ignition Module	8	Tridicator
4	Ignitor	9	Supply Water Pipe
5	Flue Gas Temperature Sensor	10	Gas Valve

4.2.1 Fan and gas valve removal instructions

SL 26-260 G3

1. Turn off the electric power and gas supply to the boiler.
2. Ensure the boiler cools down to the surrounding temperature. Do not drain the boiler unless freezing conditions are expected during this procedure.
3. Remove the front cover, and then remove the boiler upper-front cover by removing the screws at the top right and left corner of the boiler.
A ladder or step may be required to have a clear vertical view of the work area. Do not attempt to reach from the front without a clear view, as damage to connectors, screws or refractory may occur.
4. Unplug both electrical connectors from the fan.
5. Unplug the electrical connector from the gas valve.
6. Position the harnesses out of the way of the heat exchanger lid.
7. Undo the brass nut between the valve and the venturi mixing device.
8. Remove the four 8 mm hex bolts that attach the fan to the lid.
9. Remove the fan and air intake venturi assembly from the boiler.
10. Separate the fan and the venturi mixing device by removing the 3 Phillips head screws that attach the venturi mixing device to the fan.
11. Attach the venturi mixing device to the new fan.
12. Bolt the fan to the lid of the heat exchanger.
13. Attach the gas valve to the venturi mixing device with the brass coupler nut, ensuring that the gasket is in place.
14. Connect the electrical connectors to the fan and gas valve.

SL 40-399 G3

1. Turn off the electric power and gas supply to the boiler.
2. Ensure the boiler cools down to the surrounding temperature. Do not drain the boiler unless freezing conditions are expected during this procedure.
3. Remove the front cover, and then remove the boiler's upper-front cover by removing the two Phillips head screws at the top right and left corners of the boiler.
A ladder or step may be required to have a clear vertical view of the work area. Do not attempt to reach from the front without a clear view, as damage to connectors, screws or refractory may occur.
4. Unplug both the upper and lower electrical connectors from the fan.
5. Note the colors and positioning of the wire connectors, and then unplug the electrical connector from the gas valve by removing the 1/4" spade connectors.
6. Position the harnesses out of the way of the heat exchanger lid.
7. Remove the 4 hex head bolts using a 4 mm hex key that attaches the gas valve to the venturi mixing device. These screws should be first loosened slightly in a cross sequence to prevent deformation of the mating parts.
8. With the corrugated stainless steel gas line still attached to the gas valve, the gas valve can now be separated from the venturi mixing device. There is an O-ring installed between the gas inlet block and gas valve, and it should remain positioned on the block's groove. If it falls out it is important that it be positioned back on the groove or saved for re-assembly.
9. Remove the 4 hex nuts that attach the fan to the heat exchanger lid. A 7 mm open-ended wrench or socket is required.

10. With the venturi mixing device still attached, remove the fan by pulling straight up ensuring that no wires are caught and that the gas line remains in place. Place the removed components in a clean, dry area.
11. Note how the venturi mixing device is positioned on the fan before removing it from the fan. Remove the three Phillips head screws to separate the venturi mixing device from the fan.
12. Attach the venturi mixing device to the new fan.

4.2.2 Fan and gas valve re-installation

SL 26-260 G3

1. If the gas valve was removed from the venturi, ensure the gasket is in the proper position.
2. Attach the gas valve to the venturi mixing device with the brass coupler nut.
3. Re-install the fan and gas valve assembly onto the lid using the four 8 mm hex bolts removed earlier.
 - Ensure the black gasket is installed between the fan outlet and the lid.
 - Tighten by hand plus an extra 1/8 of a turn the 4 hex bolts.
 - Test for leaks around the fan and lid gasket.
4. Re-attach both fan harness connectors.
5. Re-attach the gas valve connector.
6. If a new gas valve is being installed, remove the protective cover from the gas inlet now.
7. Re-attach the gas supply line JIC connector (flare-fitting nut).
8. Open up the gas supply, and check for possible leaks.
9. Return the electric power to the boiler, and perform the startup routine.
10. Check for gas or fume leaks after 10 minutes of continuous operation.

SL 40-399 G3

1. If the gas valve has been removed, reattach it to the corrugated gas line.
2. Re-attach the venturi mixing device to the new fan, observing the alignment marks made during disassembly.
3. Ensure that the fan gasket is in place (between the heat exchanger lid and the fan).
4. Re-install the fan and venturi assembly onto the heat exchanger lid, tightening the four hex nuts by hand plus an extra 1/2 turn.
5. Plug in both the upper and lower fan harness connectors.
6. Plug in the gas valve connector.
7. If a new gas valve is being installed, remove the protective cover from the gas inlet now.
8. Re-attach the gas inlet block onto the gas valve, ensuring that the O-ring seal is in place. If this O-ring is lost, it must be replaced with a factory supplied O-ring.
9. Tighten by hand plus an extra 1/2 turn in cross sequence the 4 gas inlet block screws.
10. Open up the gas supply valve, and check for possible leaks.
11. Return the electric power to the boiler, and perform the startup routine.
12. Check for gas or fume leaks after 10 minutes of continuous operation.

4.2.3 Replacing the gas valve

SL 26-260 G3

1. Turn off the electric power and gas supply to the boiler.
2. Remove the electrical connection from the gas valve.
3. Ensure the boiler cools to the surrounding temperature. Do not drain the boiler unless freezing conditions are expected during this procedure.
4. Remove the front cover, and then remove the boiler's upper-front cover by removing the two Phillips head screws at the top right and left corners of the boiler.
A ladder or step may be required to have a clear vertical view of the work area. Do not attempt to reach from the front without a clear view as damage to the connectors, screws, or refractory may occur.
5. Support the male compression coupling on the inlet of the gas valve, and with a wrench, undo the compression fitting to separate the gas valve from the gas supply pipe.
6. To separate the gas valve from the venturi mixing device, unscrew the brass coupler nut and retain the gasket between the gas valve and the brass coupler.
7. Remove the male compression coupler from the old gas valve outlet, and install this on the new gas valve outlet, using fuel-appropriate Teflon tape on the threads.
8. Screw the brass coupler nut to the brass coupler flange on the left side of the gas valve. Ensure that the gasket is in place.
9. Supporting the male compression coupling on the outlet of the gas valve, with a wrench, tighten the compression fitting to secure the gas valve to the gas supply pipe.

SL 40-399 G3

1. Turn off the electric power and gas supply to the boiler.
2. Ensure that the boiler cools down to the surrounding temperature. Do not drain the boiler unless freezing conditions are expected during this procedure.
3. Remove the front cover, and then remove the boiler's upper-front cover by removing the two Phillips head screws at the top right and left corner of the boiler.
A ladder or step may be required to have a clear vertical view of the work area. Do not attempt to reach from the front without a clear view, as damage to connectors, screws or refractory may occur.
4. Noting the color and orientation of the connectors, unplug the 4 spade connectors from the gas valve.
5. To separate the aluminium gas block on the right side of the gas valve, remove the 4 hex head bolts with a 4 mm hex key.
6. To separate the gas valve from the venturi mixing device, remove the 4 hex head bolts on the left side of the gas valve with a 4 mm hex key.
7. Bolt the gas valve to the venturi mixing device flange with the 4 mm hex bolts, ensuring that the O-ring is positioned between the gas valve and the venturi mixing device.
8. Bolt the gas block to the gas valve outlet, ensuring that the O-ring is positioned between the gas block and the gas valve.
9. Connect the electrical connectors to the new gas valve.

NOTE

This boiler is equipped with a blocked vent shutoff system, which closes the gas supply upon detection of an irregular venting condition. In such event, the electronic controller will automatically carry out a reset/ retry every 5 minutes. See *Section 5.3.1 Airflow Error* for Troubleshooting steps.

5.0 TROUBLESHOOTING

The troubleshooting section is divided into 3 sections:

- Preliminary Checks
- Electronic Components
- Troubleshooting

Often, a problem can be identified and solved through simple checks of the basics: confirming the electrical power supply, gas flow and resetting the thermostat control. To extend the cover of such preliminary checks, the boiler’s touchscreen controller offers a clear visual display of the status of the various control circuit components.

Should a problem remain unsolved after applying the preliminary checks, proceed to the detailed system review, using the Troubleshooting section. It covers potential error conditions grouped into the following categories:

- Using touchscreen controller errors displayed
- Ignition problems
- Cycling problems
- Temperature problems
- Miscellaneous

Below each section is a list of Symptoms, Diagnoses, and Remedies.

Also provided with this manual are a number of diagrams (see Section 6.0) for use with troubleshooting including:

- Electrical wiring diagrams
- Sequence of operations flowchart
- Boiler component diagrams

5.1 PRELIMINARY CHECKS

The first step in troubleshooting this system should be a review of the touchscreen controller. There are a number of diagnostic features incorporated in the software that evaluate system integrity, display error conditions and provide initial remedial actions.

In addition to checking the display, the following list is a guideline for troubleshooting:

1. Confirm power to the boiler: check that the touchscreen controller display is on (e.g. display is lit. The touchscreen controller’s display will be fully functional in 90 seconds after power is restored to the boiler.)
2. Check that the boiler is not in a safety lockout.
3. Ensure wiring is clean and secure.
4. Check that gas is reaching the unit.
5. Confirm that the water system is properly charged to 12 and that the pump is serviceable.

5.2 ELECTRONIC COMPONENTS

This section details the method for troubleshooting the non-standard electronic components on the boiler.

5.2.1 Temperature Sensors

The resistance of the temperature sensors varies inversely with temperature. To test, measure the temperature of the sensed environment and compare with the value derived from the measurement of the resistance (obtained by connecting a good quality test meter capable of measuring up to 5,000 kΩ (5,000,000Ω) at the controller end of the sensor lead).

To obtain a resistance reading, remove power to the boiler, and return water. For the supply water and vent temperature sensors, remove the wire leads by disconnecting their respective Molex connectors. Place multi-meter probes into the sensor's female Molex connector socket. Do not apply voltage to the sensor as damage may result.

TEMPERATURE		RESISTANCE	TEMPERATURE		RESISTANCE
°F	°C	Ω	°F	°C	Ω
0	-18	85,362	100	38	5,828
5	-15	72,918	105	41	5,210
10	-12	62,465	110	43	4,665
15	-9	53,658	115	46	4,184
20	-7	42,218	120	49	3,760
25	-4	39,913	125	52	3,383
30	-1	34,558	130	54	3,050
35	2	29,996	135	57	2,754
40	4	26,099	140	60	2,490
45	7	22,763	145	63	2,255
50	10	19,900	150	66	2,045
55	13	17,436	155	68	1,857
60	16	15,311	160	71	1,689
65	18	13,474	165	74	1,538
70	21	11,883	170	77	1,403
75	24	10,501	175	79	1,281
80	27	9,299	180	82	1,172
85	29	8,250	185	85	1,073
90	32	7,334	190	88	983
95	35	6,532	195	91	903

Table 9: Temperature Sensor resistance values

5.2.2 Fan

Operating power is provided by means of a separate 120 VAC connector (white/black/green). Control of the fan is provided via a four lead connector. This connector feeds a PWM control signal (black wire) from the controller and provides a tachometer signal (white wire) back from the fan. Unplugging the control connector will cause the fan to go to high speed and trigger a “Blocked Vent Error” within 6 seconds if the boiler is operating.

LEAD COLOR	FUNCTION	TROUBLESHOOTING
Red	35 VDC Positive power terminal	Fan will only operate at max. speed if disconnected.
Blue	35 VDC Negative power terminal	Fan will only operate at max. speed if disconnected.
Black	Signal from controller	Fan will only operate at max. speed if disconnected.
White	Fan tach.	2 pulses/rev (freq x 30=rpm)

Table 10: Fan Operation

5.2.3 Water Pressure Sensor

The water pressure sensor ensures that there is adequate pressure in the heating system for safe operation. The pressure is displayed in PSI as the default. If the system pressure should drop below 8PSI the firing rate of the boiler is reduced. If the pressure drops to 4PSI or lower, the boiler will not fire.

Check the operation of the sensor by isolating the boiler from its system piping, and close the system fill valve, and then crack the pressure relief valve. The pressure displayed should reflect declining pressure. If it remains “fixed”, drain the boiler and replace the sensor, or dislodge any blocking debris from the sensor inlet channel and reinsert.

5.2.4 Safety and Ignition Module (SIM)

The SIM is a safety control that is certified to conform to the UL 60730-5-5 and ANSI Z21.20-2014 • CAN/CSA-C22.2 No. 60730-2-5-14 Standards. The low water cutoff function and the high-limit manual reset water temperature function also conform to these standards.

The SIM directly controls the boiler’s gas valve and provides:

- Direct spark automatic ignition
- Flame detection and current measurement
- Supply water temperature sensing
- Flue gas temperature sensing
- Supply water maximum temperature shutdown
- Flue gas maximum temperature shutdown
- Low water cut-off.

The SIM's two status LEDs indicate the operating status as shown in the table below.

Status Indicators

LED 1	LED 2	STATE	DESCRIPTION, LED STATUS INDICATION
Rapid Flash	Rapid Flash	Power up or Resetting	Startup checks and initialization
Off	Off	Standby	LED1 Off = No Flame or Sparking LED 2 = Burner-On Call state
Off	On	Pre-Purge or Inter-Purge	LED1 Off = No Flame or Sparking LED 2 = Burner-On Call state
On	On	Heating	LED 1 On = Flame detected LED 2 = Burner-On Call state
Rapid Flash	On	Igniting	LED 1 flashing = Electrode Sparking, LED 2 = Burner-On Call state
Off	Flashing	Lockout	An operating limit was exceeded or a sequence failed or an external sensor fault was detected.
Flash Alternately with LED 2	Flash Alternately with LED 1	Fail-Safe	A critical internal fault was detected.

The SIM continuously communicates with the boiler's main controller reporting sensor readings and status. The sensor readings and error status, if any are displayed on the boiler controller's screen.

5.2.4.1 Low water cutoff function: reset and test

The low water cutoff (LWCO) function provides continuous protection against a low water incident.

If the SIM detects a low water incident, the boiler goes into a lockout condition. Here, you will need to reset the boiler. To test the LWCO on the boiler, you can also manually place the boiler in a lockout condition (locks).

Resetting the boiler after a LWCO lockout

Before you reset the boiler, ensure that the boiler is pressurized and that the air has been removed.

1. On the touchscreen controller, tap the Home screen.
2. On the **Main Menu**, tap the **Diagnostics** button.
3. Tap the **Advanced Diagnostics** button.
4. Tap the **Clear Errors** button.
5. Tap the **Yes** radio button, and then tap **OK**.

The system clears the errors, and resets the boiler.

Testing the LWCO function

1. On the touchscreen controller, tap the Home screen.
2. On the **Main Menu**, tap the **Diagnostics** button.
3. Tap the **SIM Module** button.

4. Tap the **LWCO Test** button.
5. Disconnect the yellow wire from the LWCO function.
A message on the screen indicates that the boiler is in lockout mode.
6. To reset the boiler, reconnect the yellow wire to the LWCO function.

On the touchscreen controller, tap the **Reset** button.

The message: "The SIM Module has been reset" is displayed.

7. Tap the **Close** button, and then tap the **Back** button until you return to the Home screen.

5.2.4.2 Water Temperature function: reset and test

The hi-limit temperature function monitors the hi-limit temperature set in the SIM. If the water temperature exceeds the hi-limit temperature, the boiler goes into a lockout condition (locks), requiring a manual reset. You can test the hi-limit cutoff temperature function on the boiler.

Resetting the boiler after a Hi-Limit lockout

Before you reset the boiler, ensure that the boiler is pressurized and that the air has been removed.

1. On the touchscreen controller, tap the Home screen.
2. On the **Main Menu**, tap the **Diagnostics** button.
3. Tap the **Advanced Diagnostics** button.
4. Tap the **Clear Errors** button.
5. Tap the **Yes** radio button, and then tap **OK**.

The system clears the errors, and resets the boiler.

Testing the Hi-Limit cutoff temperature function

1. On the touchscreen controller, tap the Home screen.
2. On the **Main Menu**, tap the **Diagnostics** button.
3. Tap the **SIM Module** button.
4. Tap the **Hi-Limit Test** button.

You will need to enter a cutoff temperature below the Supply Temp. value currently displayed. For example, if the Supply Temp. value is 180°F, enter 170°F in the Cut Off Temp. box.

5. Tap inside the **Cut-Off Temp.** box, and then tap a number value.
6. Tap the **OK** button.

The message: "Hi-Limit Detected" is displayed.

7. To reset the boiler, select the **Reset** button.

The message: "The SIM module has been reset" is displayed.

8. Tap the **Close** button, and then tap the **Back** button until you return to the Home screen.

5.3 TROUBLESHOOTING

WARNING

Never attempt to repair the control module (circuit board). If the control module is defective, replace it immediately.

5.3.1 Using Control Module Errors Displayed

The bottom line of the touchscreen is reserved for displaying the boiler's error status. The boiler status bar will normally be Green, but can change color to Yellow or Red. The colors represent the following boiler operating status. The text inside the bar will indicate the specific warning or alarm. If there is more than one alarm present the text will scroll slowly through all current alarm conditions.

- Green – Normal
- Yellow – Warning
- Red – Alarm

SYMPTOM	DIAGNOSIS	REMEDY
<p>MAXIMUM IGNITION TRIALS ERROR</p> <p>Touchscreen Message:</p> <p>Error – Ignition Failure after 3 tries</p> <p>Boiler has failed to ignite on 3 successive attempts. Boiler in lockout for 1 hour, then repeats 3-try seq. Consult service technician if error recurs.</p>	<p>No spark when igniting. Igniter probe/flame sensor disconnected.</p>	<p>Check that igniter lead is secure at the touchscreen controller and at the probe.</p>
	<p>Manual gas shutoff is closed or gas line not fully purged.</p>	<p>Check for gas flow. Open manual gas shutoff and reset boiler.</p>
	<p>Gap between igniter probe rods is too large or too small.</p>	<p>Adjust ignitor probe rod gap between 1/8th and 3/16th (3.2-4.7 mm)</p>
	<p>Spark, but no ignition.</p>	<p>Check spark module is sending power to gas valve – close gas supply, then disconnect (black) electric housing from face of gas valve, gently spread plastic tabs to open, and look for 24vac voltage between blue and brown wires during an ignition cycle. Replace module if no current detected</p>
	<p>Boiler ignites, but shuts off at the end of the ignition trial. Improperly grounded pressure vessel/ burner or unserviceable ignition lead or spark module.</p>	<ul style="list-style-type: none"> • Ensure pressure vessel is grounded. • Check the igniter probe/flame sensor is electrically isolated from the vessel, and its ceramic insulator is intact. • Replace ignition lead • Replace spark module
<p>HI LIMIT CUTOFF TEMPERATURE ERROR</p> <p>Touchscreen message:</p> <p>Error – Water High-Limit Exceeded</p>	<p>Water temperature exceeds hi-limit. Boiler in hard lockout.</p>	<p>See Section 5.2.4.</p>

SYMPTOM	DIAGNOSIS	REMEDY
LOW WATER CUTOFF ERROR Touchscreen message: Error - Low Water Cutoff	The Safety and Ignition module has detected a low water condition.	See Section 5.2.4.

SYMPTOM	DIAGNOSIS	REMEDY
TEMPERATURE SENSOR ERROR Touchscreen Message: Error - Max. Inlet/Outlet Sensor Temp. Exceeded. -> Check water flow Water temperature signal not within acceptable range. Potential flow or sensor failure. Consult service technician.	Current outlet temperature exceeds operating limit.	<ul style="list-style-type: none"> • Check water flow.
	Defective or disconnected temperature sensor.	<ul style="list-style-type: none"> • Check wiring to temperature sensor and control module. • Check temperature sensor. See Section 5.2.1.
MISCELLANEOUS Touchscreen Message : Blank – screen dark, but fan running Indicative of power-surge damage to appliance		<ul style="list-style-type: none"> • Check transformer; replace if damaged. • Check circuit board for visible damage.

5.3.2 Ignition Problems

SYMPTOM	DIAGNOSIS	REMEDY
NOISY SPARK WHEN IGNITING	Ignition lead is not firmly connected.	Reconnect ignition lead.
	Contaminants/moisture on igniter probe/flame sensor.	Ensure probe is dry by re-running post-purge; otherwise, clean or replace igniter probe.
BOILER RUMBLES WHEN IGNITING.	Fluctuating gas pressure/ gas pressure too high/too low.	Check CO ₂ level via analyzer.
	Check for proper gas piping.	Check pressure with manometer during ignition.
BOILER WILL NOT ATTEMPT TO IGNITE. FAN AND PUMP ARE OPERATING NORMALLY.	No power to ignition control module.	<ul style="list-style-type: none"> • Check system wiring. • Check air reference tubing.
	Igniter probe/flame sensor disconnected.	Reconnect probe.
	Defective Control Module.	Check ignition output from control module.
BOILER WILL NOT ATTEMPT TO IGNITE. FAN AND / OR PUMP ARE OFF DISPLAY NOT ILLUMINATED	No power to boiler.	Check line voltage.
	Defective transformer.	Check transformer. Reconnect or replace as needed.

5.3.3 Cycling Problems

SYMPTOM	DIAGNOSIS	REMEDY
RAPID CYCLING	Improper values entered via keypad.	Check load maximum temps are above target temps, by 1/2 of the selected boiler differential. Ensure boiler differential is OK (16-30°F is generally adequate)
	Excess Condensate in venting.	Check venting slopes on horizontal runs. Look for sags.
	Obstruction in condensate trap.	Inspect and clean condensate trap.
	Improper vent length or improper slope to vent.	Check venting. Compare vent length and diameter to Table 4A or Table 4B: Maximum Venting.
	Incorrect settings or defective thermostat.	Check operation. Refer to manufacturer's instructions. Check setting with ammeter.
	Air in system or marginal water flow.	Bleed/purge system as required. Confirm adequate pump size and temp rise in HX.
	Slow combustion air blower.	Check that CO ₂ level is within specification.
	Dirty burner/heat exchanger.	Check pressure drop.
	Low water flow due to improper piping.	Refer to recommended piping in <i>Section 1.6</i>
	Low water flow due to undersized pump.	Check manufacturer's rating charts/check temperature differential across heat exchanger.
	Low water flow due to restrictions in water pipe.	Check temperature differential across zone/heat exchanger.
	Low radiation.	Check actual amount of radiation per zone and refer to manufacturer's rating tables.
	Unit over-fired.	Clock gas meter/check gas pressure with manometer/ check CO ₂ level.
	Unit Oversized.	Check load calculation vs. min. boiler output.
Improperly set or defective operating/ safety controls.	Check operation with ohmmeter/voltmeter.	

5.3.4 Temperature Problems

SYMPTOM	DIAGNOSIS	REMEDY
LOW HEAT	Operating temperature too low.	Increase temperature target.
	Priority parameters or load configuration improperly set up.	Review load configuration parameters.
	Unit undersized.	Refer to Load Calculation vs. Boiler Output.
	Air trapped within system.	Bleed system as required.
	Improper system piping.	Refer to recommended piping in Section 1.6
	System pump undersized.	Check pump manufacturer's data/check temp differential across heat exchanger.
	Poor gas/air mixing.	Check CO ₂ level.
	Defective thermostat.	Refer to manufacturer's instructions.
	Obstruction in condensate drain.	Inspect and clean condensate drain.
	Unit cycling on operating/ safety controls.	Check operation with Ohmmeter/Voltmeter.
	System radiation undersized.	Check manufacturer's rating tables for capacity per foot.
TEMPERATURE EXCEEDS THERMOSTAT SETTING	Incorrect anticipator setting.	Check with Ammeter.
	Thermostat not level.	Check level.
ONE OR MORE ZONES DO NOT HEAT PROPERLY	Air trapped within zone(s) piping	Vent system/zone as required.
	Low radiation/ excessive heat loss.	Check actual length of pipe using radiation / heat loss calculation.
	Low flow rate to zone(s).	Check temperature drop across zone.
	Defective zone valve/ zone circulator.	Check operation per manufacturer's instructions.

5.3.5 Miscellaneous

SYMPTOM	DIAGNOSIS	REMEDY
FUMES AND HIGH HUMIDITY	Improperly installed condensate trap	Refer to installation/operation instructions
	Leak in vent piping	Inspect using soap solution
	Flue gas leak within boiler	Visually inspect all mechanical connections
BOILER STUCK ON INITIALIZE	Fan board failure	Replace fan.
TOUCHSCREEN MESSAGE: Unknown Error	Temperature sensor input problem.	Test each temperature sensor for appropriate readings and Replace defective temperature sensor.
BOILER REMAINS IN STANDBY DURING CALL FOR RESET HEATING OR SET-POINT (DHW OPERATION WORKS AS NORMAL). (5 BUTTON CONTROLLER)	Boiler may be in Warm Weather Shut-down.	In Installer Setup / Heat Load Configuration / Configure Load (Heating) adjust Summer Shutdown Temperature to a temperature above that registered by outdoor sensor.
'GHOST' CALL FOR HEAT.	Triac or 'Power-robbing' thermostat sending current to boiler.	Remove Therm. connections from boiler to confirm that stray voltage, or current induced in thermostat wiring, is source of nuisance signal. Replace the Power Robbing thermostat, isolate the thermostat with a relay or install a properly sized resistor (consult the thermostat manufacturer first then IBC for instructions).
ERROR: WATER HIGH LIMIT / LOW WATER CUTOFF WON'T CLEAR.	Boiler is in 1 hour safety lockout.	Reset safety device and cycle boiler power off and on to reset error.
DHW TAKING TOO LONG TO HEAT.	Sensor may be under-reading actual water temp.	Check sensor engagement; note well is 15cm / almost 6 inches deep and sensor must be fully set to back. Check programmed settings boiler temp set too close to the required DHW temp
BOILER OUTPUT NOT MODULATING UP TO MAXIMUM DESPITE TARGET NOT BEING REACHED.	Possible flow issue: check for 35 or 40 degree F temperature difference between boiler supply and return water temperatures (evokes electronic fence).	Confirm that primary pump is able to overcome head loss of boiler and primary loop piping at the required flow rate.
PRIMARY PUMP RUNS BUT LOAD PUMPS DO NOT.	Wiring not complete.	Supply power to the PV/L and PV/N terminals from the incoming power supply to the boiler. (Factory wired on boilers with a factory installed Touchscreen Controller)
PRIMARY PUMP RUNS DURING PARALLEL-PIPED DHW CALL.	Load definition as DHW.	Re-define DHW load as DHW Loop 2 (5 button Controls) to turn off primary pump during domestic hot water calls. On Touchscreen Controllers set the boiler pump to off in the Installer Set-up Menu.

THIS PAGE IS INTENTIONALLY LEFT BLANK.

6.0 DIAGRAMS

This section includes:

- Parts diagrams
- Wiring diagrams
- The sequence of operation

6.1 PARTS DIAGRAMS

SL 26-260 G3 Boiler - Parts assembly

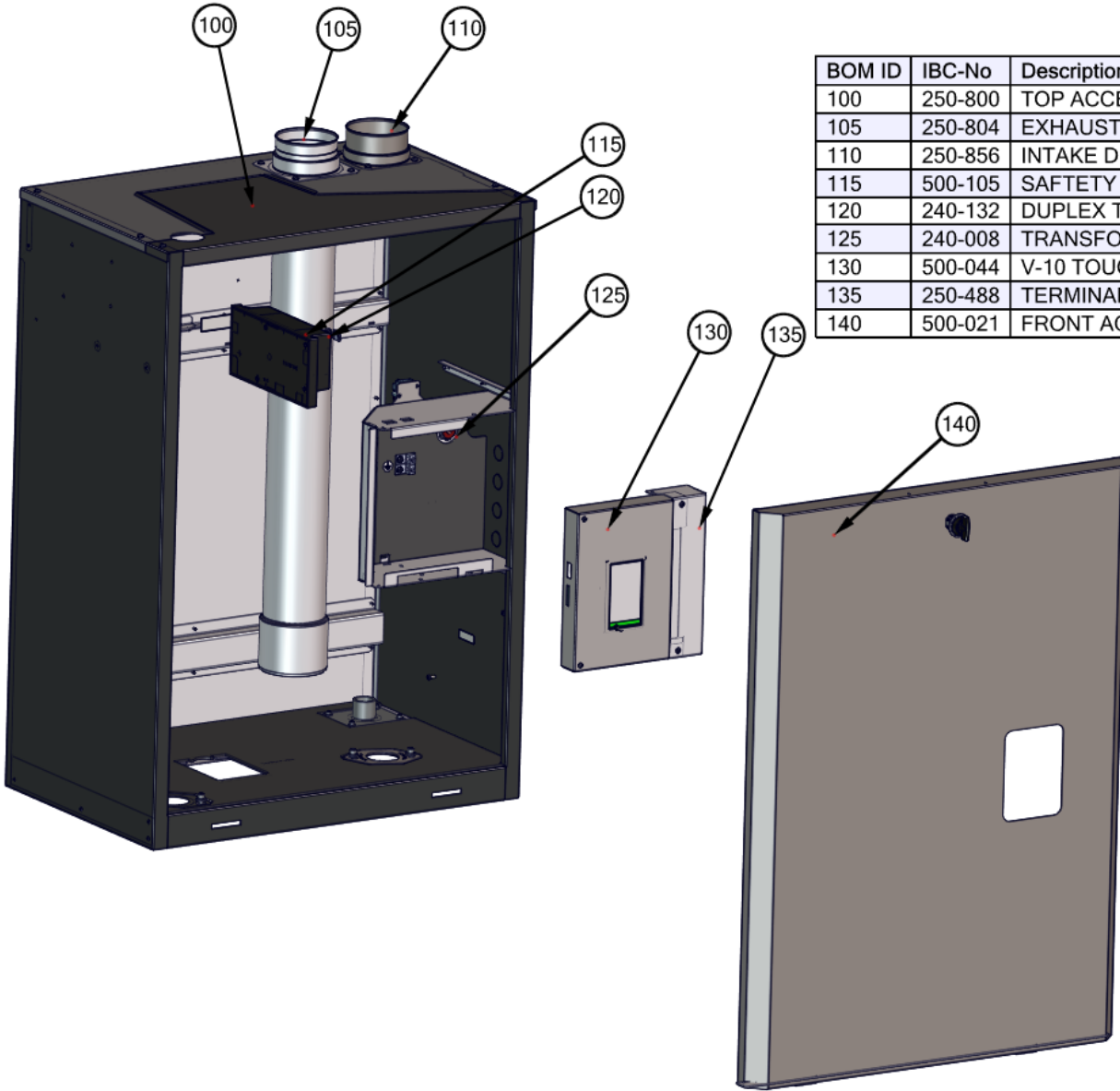

BOM ID	IBC-No	Description	Qty
100	250-800	TOP ACCESS COVER	1
105	250-804	EXHAUST DUCT	1
110	250-856	INTAKE DUCT	1
115	500-105	SAFTETY IGNITION MODULE	1
120	240-132	DUPLEX TEMPERATURE SENSOR	1
125	240-008	TRANSFORMER	1
130	500-044	V-10 TOUCHSCREEN CONTROLLER	1
135	250-488	TERMINAL BLOCK COVER	1
140	500-021	FRONT ACCESS COVER	1

Diagram 6.1-1: Boiler assembly parts - SL 26-260 G3

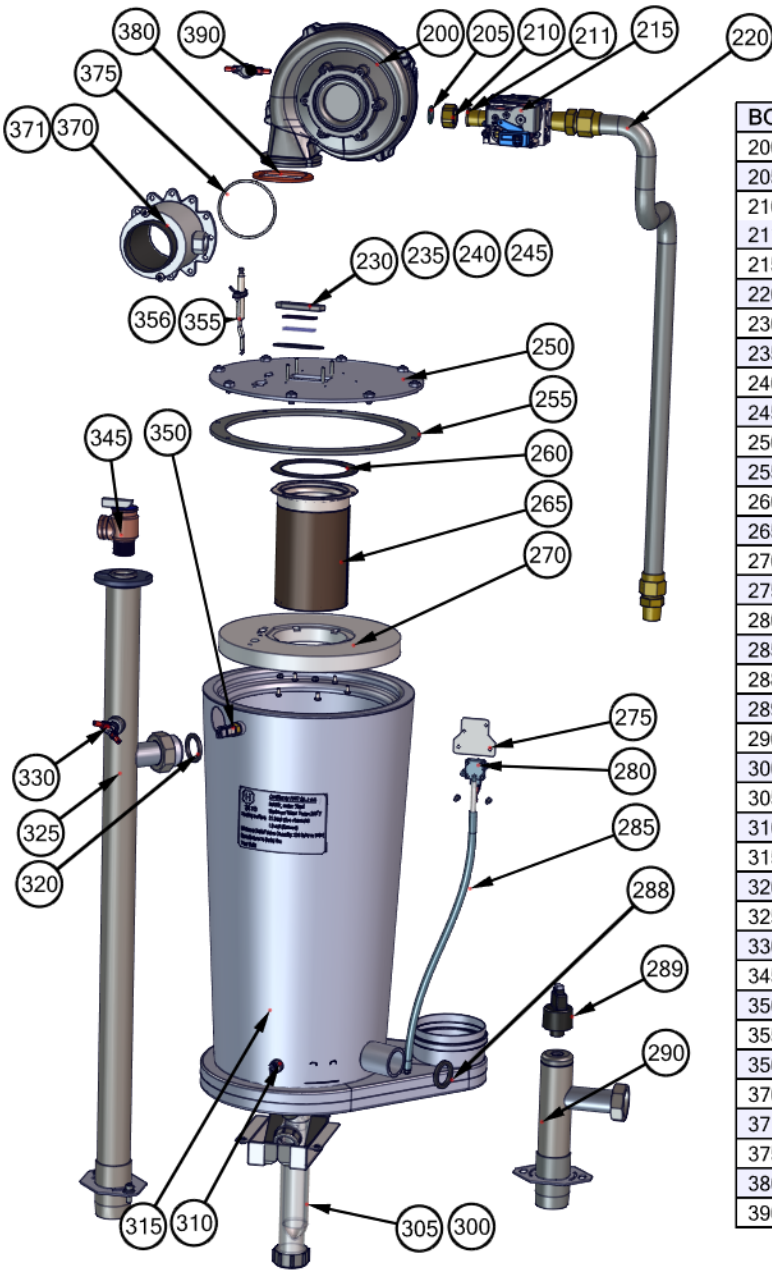

BOM ID	IBC-No	Description	Qty
200	240-113	FAN	1
205	250-742	GAS VALVE COUPLER GASKET	1
210	250-741	GAS VALVE COUPLER NUT	1
211	250-768	GAS VALVE COUPLER	1
215	180-166	GAS VALVE	70
220	190-157	GAS LINE PIPE	1
230	250-057	SIGHT GLASS FRAME	1
235	255-025	SIGHT GLASS UPPER GASKET	1
240	250-059	SIGHT GLASS	1
245	255-023	SIGHT GLASS LOWER GASKET	1
250	170-032	HEAT EXCHANGER LID	1
255	255-026	HEAT EXCHANGER GASKET	1
260	255-034	BURNER GASKET	1
265	180-186	BURNER	1
270	250-761	HEAT EXCHANGER REFRACTORY	1
275	250-867	PRESSURE SWITCH BRACKET	1
280	240-138	BLOCKED VENT PRESSURE SWITCH	1
285	190-165	PRESSURE SENSOR TUBE	1
288	255-024	WATER PIPE GASKET	1
289	240-006	WATER PRESSURE SENSOR	1
290	250-258	RETURN WATER PIPE	1
300	250-664	CONDENSATE TRAP RETAINER	1
305	180-013	CONDENSATE TRAP	1
310	240-134	TEMPERATURE SENSOR	1
315	170-032	HEAT EXCHANGER	1
320	250-024	SUPPLY WATER PIPE GASKET	1
325	250-259	SUPPLY WATER PIPE	1
330	240-010	LOW WATER CUTOFF PROBE	1
345	180-005	PRESSURE RELIEF VALVE 30 PSI	1
350	240-133	SUPPLY WATER TEMPERATURE SENSOR	1
355	240-002 or 240-141	IGNITOR	1
356	250-050	IGNITOR GASKET	1
370	180-161	FUEL MIXER NG	1
371	180-162	FUEL MIXER LP	1
375	150-073	MIXER O-RING	1
380	250-322	FAN GASKET	1
390	240-030	VESSEL HIGH-LIMIT SWITCH	1

Some parts are available only in Kits. Please visit www.ibcboiler.com for more information.

SL 40-399 G3 Boiler - Parts assembly

BOM ID	IBC-No.	Description	Qty
105	250-693	TOP ACCESS COVER	1
110	250-025	INTAKE DUCT	1
115	500-105	SAFETY IGNITION MODULE	1
120	240-138	PRESSURE SWITCH	1
125	250-870	PRESSURE SWITCH BRACKET	1
130	240-030	VESSEL TEMP. HIGH LIMIT SWITCH	1
135	240-008	TRANSFORMER	1
140	250-488	TERMINAL BLOCK COVER	1
145	500-044	CONTROLLER V-10 COVER	1
150	500-079	FRONT ACCESS COVER	1

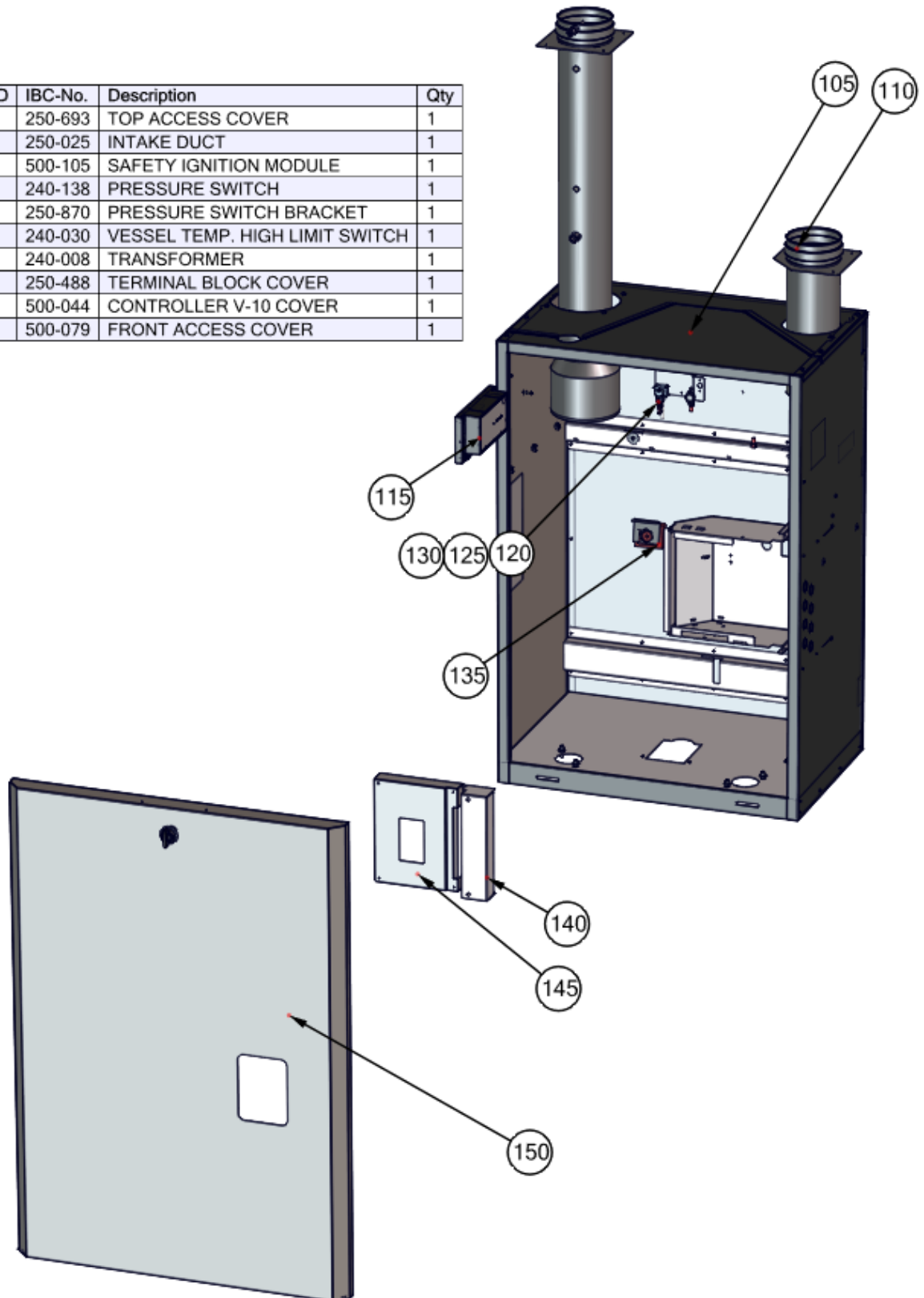
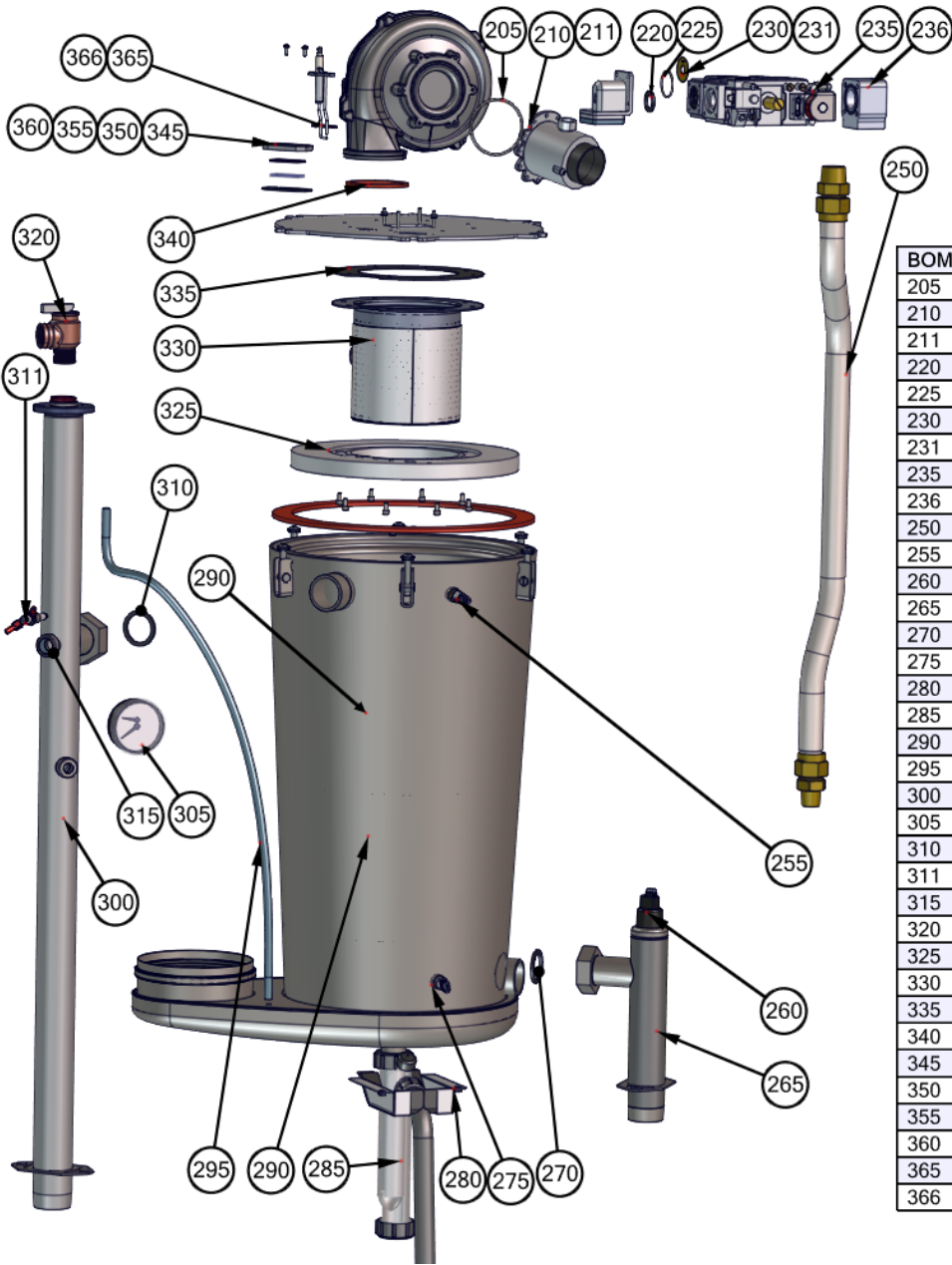

Diagram 6.1-2: Boiler assembly parts - SL 40-399 G3



BOM ID	IBC-No.	Description	Qty
205	150-073	MIXER O-RING	1
210	180-164	FUEL MIXER LP	1
211	180-163	FUEL MIXER NG	1
220	250-035	GAS VALVE COUPLER GASKET	1
225	150-259	O-RING	1
230	250-869	ORIFICE NG	1
231	250-865	ORIFICE PROPANE	1
235	180-150	GAS VALVE	1
236	250-755	GAS INLET BLOCK	1
250	190-158	GAS LINE	2
255	240-133	SUPPLY WATER TEMP. SENSOR	1
260	240-006	WATER PRESSURE SENSOR	1
265	250-748	RETURN WATER PIPE	1
270	255-027	WATER PIPE GASKET	1
275	240-134	RETURN WATER TEMP. SENSOR	1
280	250-664	CONDENSATE RETAINER	1
285	180-065	CONDENSATE TRAP	1
290	170-029	HEAT EXCHANGER	1
295	190-165	PRESSURE SENSOR TUBE	1
300	250-853	SUPPLY WATER PIPE	1
305	180-019	TRIDICATOR	1
310	255-027	WATER PIPE GASKET	1
311	240-010	LOW WATER CUTOFF PROBE	1
315	240-132	FLUE GAS TEMP. SENSOR	2
320	180-005	PRESSURE RELIEF VALVE	1
325	250-753	HEAT EXCHANGER REFRACTORY	1
330	180-185	BURNER	1
335	255-048	BURNER GASKET	1
340	250-322	FAN GASKET	2
345	255-025	SIGHT GLASS FRAME	1
350	255-060	SIGHT GLASS UPPER GASKET	1
355	250-059	SIGHT GLASS	1
360	255-023	SIGHT GLASS LOWER GASKET	1
365	240-002 or 240-141	IGNITOR	1
366	250-050	IGNITOR GASKET	1

Some parts are available only in Kits. Please visit www.ibcboiler.com for more information.

THIS PAGE IS INTENTIONALLY LEFT BLANK.

6.2 WIRING DIAGRAMS

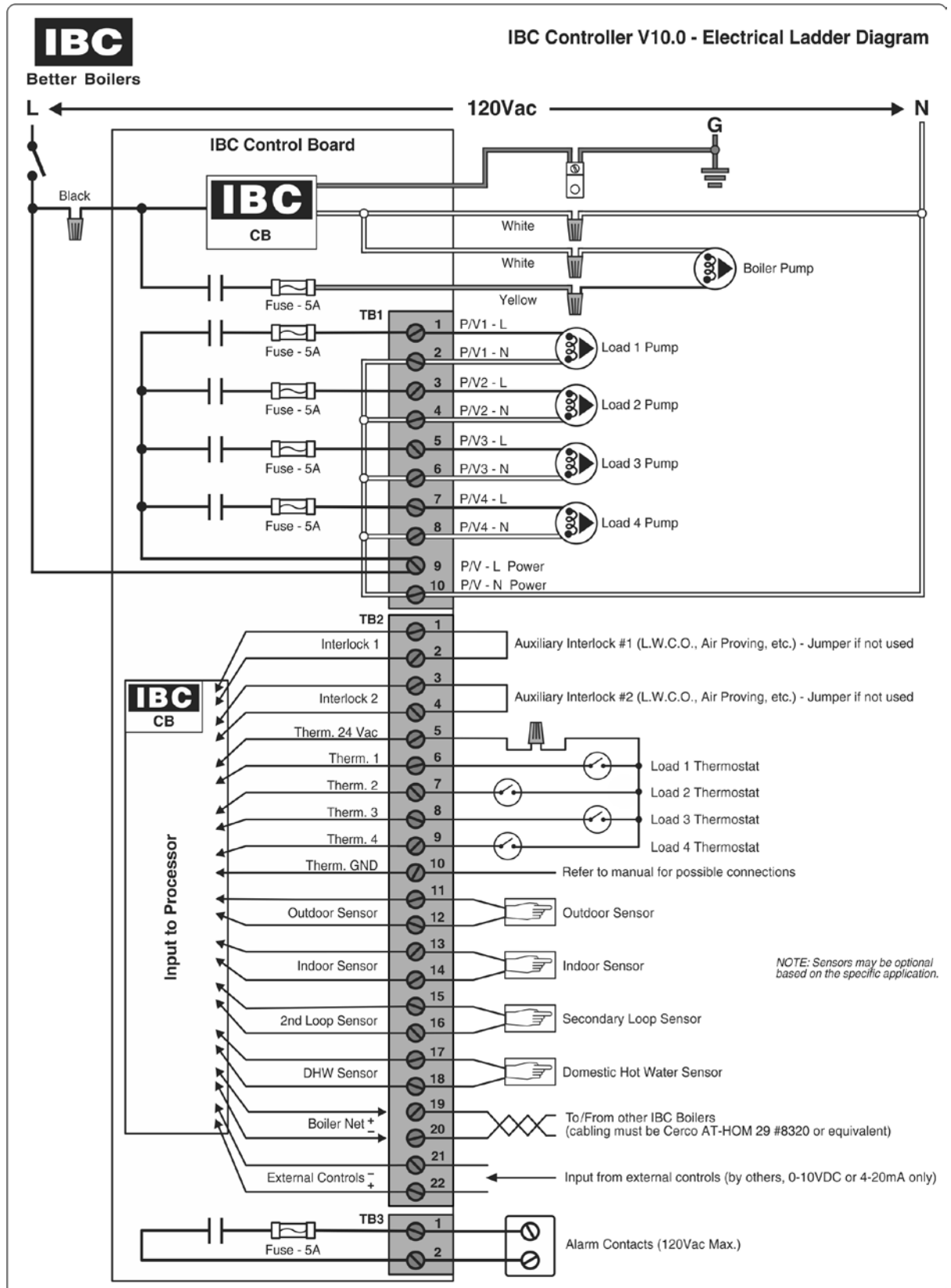

Diagram 6.2-1: Ladder wiring diagram

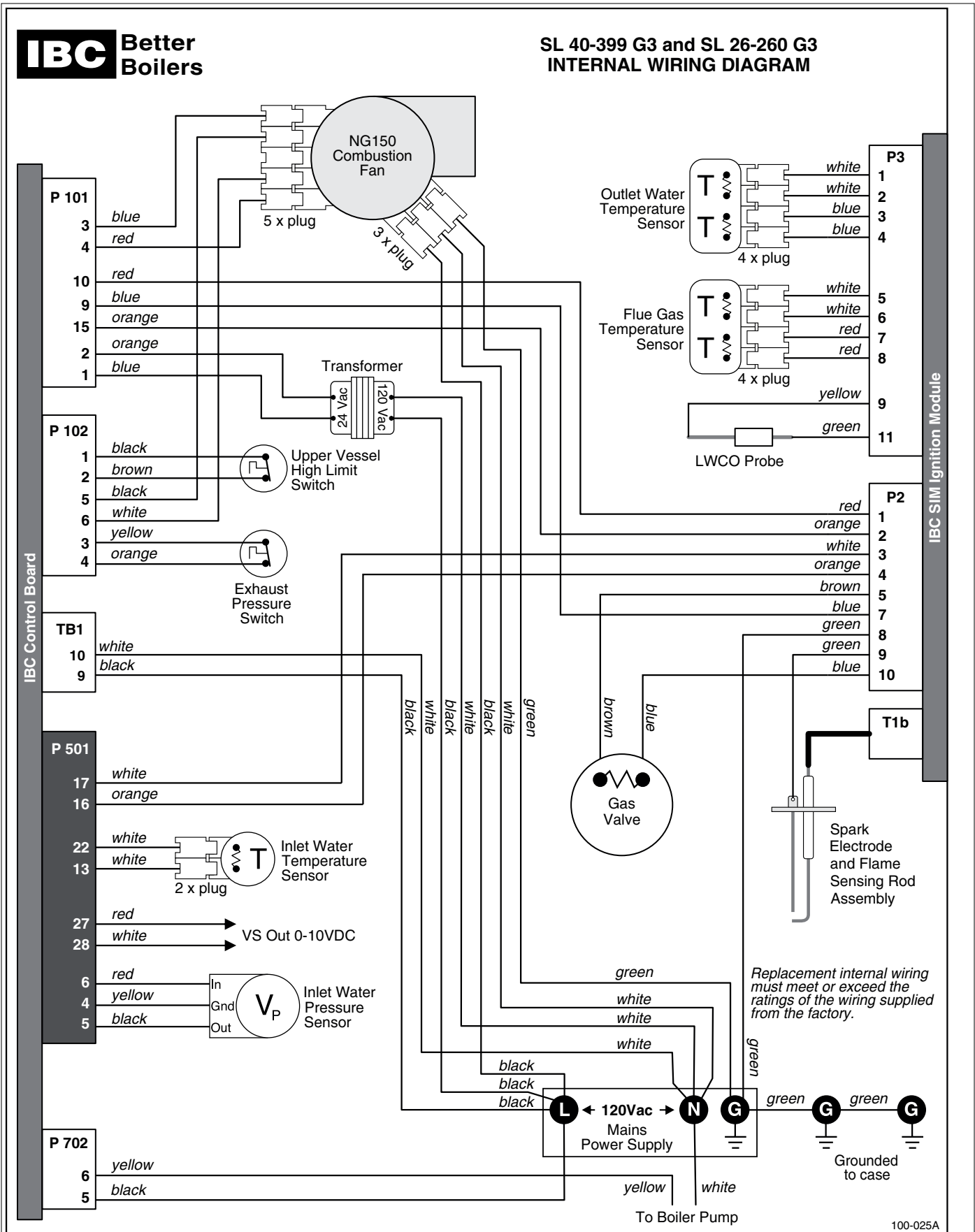

Diagram 6.2-2: Internal wiring diagram

6.3 SEQUENCE OF OPERATION

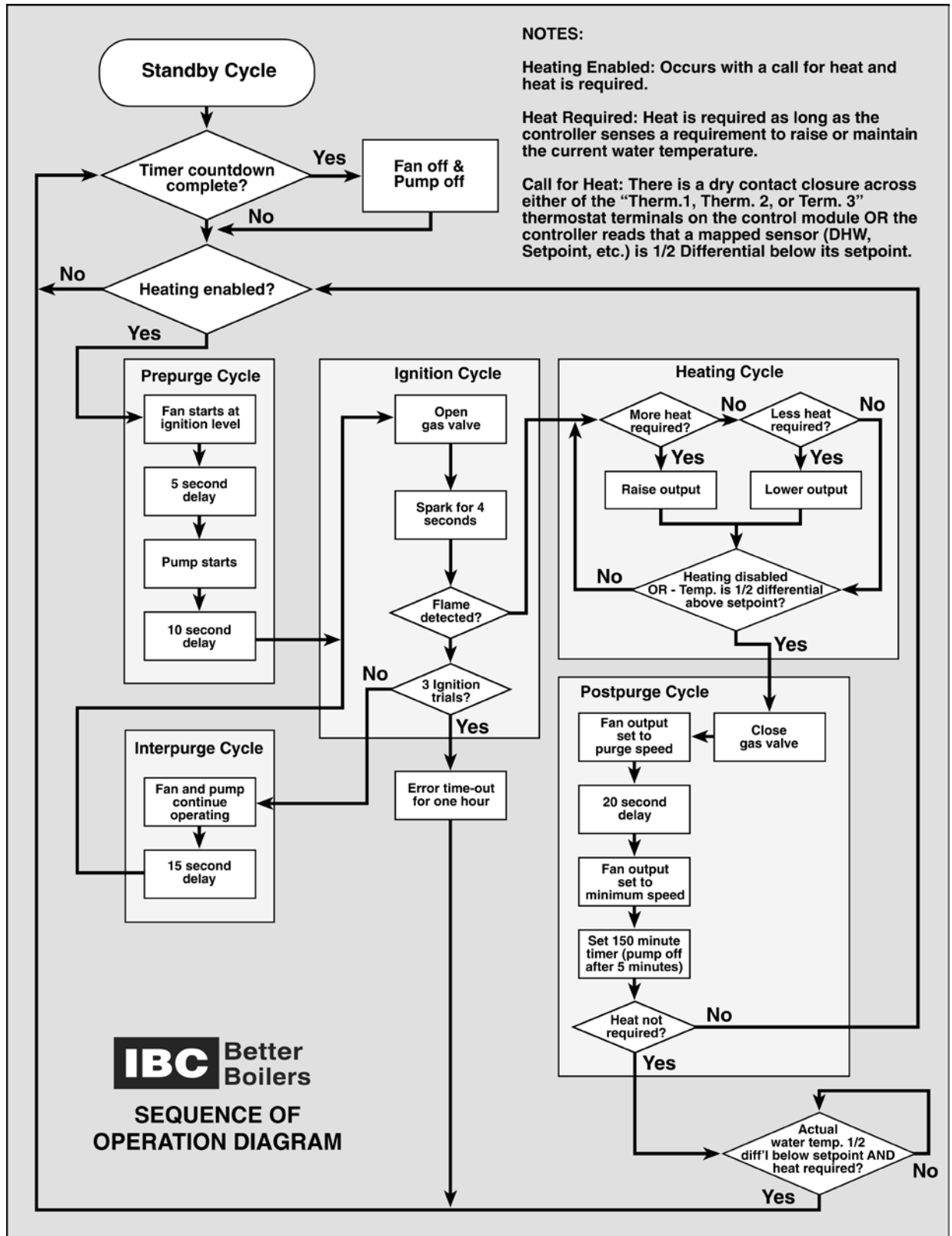

Diagram 6.3: Sequence of operation diagram

INSTALLATION & COMMISSIONING REPORT

Boiler Details:

Model Number _____ Serial Number _____

Date of Installation _____ Address of installation _____

User contact information _____

Installer Information Company _____

Address _____

Phone/Fax/E mail _____

Fuel Natural Gas Propane

Gas Supply Pressure (high fire) _____ Inches w.c. Measured Rate of Input (high fire) _____ Btu/hr

Installation instructions have been followed and completed (Section 1 of Installation and Operating Instructions).

Check-out procedures have been followed and completed (Section 3 of Installation and Operating Instructions).

Leak testing completed gas piping venting system Fan and combustion components

System Cleaned and Flushed (type of cleaner used) _____

System Filled (type/concentration of any glycol/chemicals used) _____

Air purge completed

Relief Valve correctly installed and piped Relief valve "try lever" test performed

Condensate trap filled Condensate drain clear and free flowing Condensate Neutralization? Yes/No

Ignition Safety Shutoff test completed. Flame current reading - High fire _____ μ A - Low fire _____ μ A

Owner advised and instructed in the safe operation and maintenance of the boiler and system.

Information regarding the unit and installation received and left with owner

Combustion Readings:

CO₂ _____ % O₂ _____ % CO _____ ppm

Flue temperature _____ Return water temperature (measure simultaneously with flue temp.) _____

Installers: send this completed sheet - Fax to 604 877 0295 - or - scan and Email to info@ibcboiler.com.

Commissioning has been completed as listed on this report - Installer Signature _____

INSTALLER SET-UP

Load Definition - Load #1 _____

Load Configuration - Load #1

Load Definition - Load #2 _____

Load Configuration - Load #2

Load Definition - Load #3 _____

Load Configuration - Load #3

Load Definition - Load #4 _____

Load Configuration - Load #4

As referenced on page 2-7 of this manual, the following message is relevant to users in the USA:

IMPORTANT

This Boiler is equipped with a feature that saves energy by reducing the boiler water temperature as the heating load decreases. This feature is equipped with an override which is provided primarily to permit the use of an external energy management system that serves the same function. **THIS OVERRIDE MUST NOT BE USED UNLESS AT LEAST ONE OF THE FOLLOWING CONDITIONS IS TRUE:**

- An external energy management system is installed that reduces the boiler water temperature as the heating load decreases.
- This boiler is not used for any space heating.
- This boiler is part of a modular or multiple boiler system having a total input of 300,000 BTU/hr or greater.
- This boiler is equipped with a tankless coil (not applicable to IBC's SL boilers).

US installers should contact IBC for any further information required.

REVISION HISTORY

R1 (March 2017)	Initial release
R2 (April 2017)	Corrections to text (Specifications table and part number tables)
R3 (May 2017)	Revisions to tables.
R4 (March 2018)	Changes to gas valve images (ref: Figure 37A & B), removal of snorkel and gas valve orifice.

IBC Technologies Inc.

8015 North Fraser Way
Burnaby, BC
Canada V5J 5M8

Tel: 604-877-0277

Fax: 604-877-0295

Toll Free: 1-844-432-8422

www.ibcboiler.com

March 2018

© IBC Technologies Inc. 2018



120-270E-R4