



VHBXB-HW Series

Variable Speed
1.5 - 5.0 Tons Cooling
Up to 132,400 BTUH Hot Water Heating
Without HW Pump



In addition to all the popular features of its sister product (the HBXB-HW Series), the VHBXB-HW series includes a programmable, high efficiency motor that redefines comfort and energy savings. The VHBXB-HW motor automatically adjusts its torque and speed to maintain a preprogrammed level of constant airflow over a wide range of external static pressures. This variable speed technology offers better indoor air quality, more precise humidity control, quieter operation, consistent indoor air temperature, and lower utility bills.

High Efficiency - At full load conditions the VHBXB-HW motor is 20% more efficient than an induction motor and at constant fan speed it consumes only 60-80 watts of power compared to 400 watts for a standard induction motor. In addition, the VHBXB-HW includes a high efficiency "A" coil with factory installed TXV for precise refrigerant control.

These fan coils are compatible with any source of hot water that doesn't exceed 180° and is NSF/ANSI certified for use with domestic water.

(1) **First Co's customer is ultimately responsible for confirming which fan coil models are compatible with selected outdoor unit(s) and which expansion valves (if any) are required. to determine certified indoor/outdoor matches, go to: www.firstco.com or contact the factory.**

Quiet Operation - The versatile VHBXB-HW motor quietly "ramps up" when the unit is turned on and "ramps down" when the thermostat is satisfied, eliminating the annoying sounds of changing airflow.

Self-Regulating Constant Airflow - The VHBXB-HW motor is factory programmed to maintain a predetermined level of airflow over a wide range of external static pressures, ensuring optimum system performance and whole-house comfort. The benefits of constant fan operation are:

- **Consistent air distribution** (and temperature) throughout the home
- **Better indoor air quality** (further improved with the addition of a high efficiency filter) - This allows the air to be filtered without excessive drafts and without sacrificing efficiency.
- **Better humidity control** - The VHBXB-HW is designed to extract much more moisture from the air than a conventional system by slowing the airflow over the cooling coil. The result is an improved summer comfort level at higher indoor temperature.

Additional Standard Features:

- Factory installed R22 or R410A TXV (non-bleed type)
- Blower door safety switch (except 48/60VHBXB-HW)
- Convenient connections for boiler or switching relay
- Hot water coil assembly slides out for easier service
- Manual air vent on hot water coil
- Attractive baked-on powder coat finish
- Fully insulated cabinet
- Primary and secondary drain connections on cooling coil
- Optional hot water coil freeze protector
- Upflow / Horizontal drain pans
- Higher efficiency pleated filter
- Compatible with most properly sized and installed zone control systems. Contact the zone control manufacturer.
- Cabinet air leakage is no more than 2% when tested in accordance with ASHRAE 193.

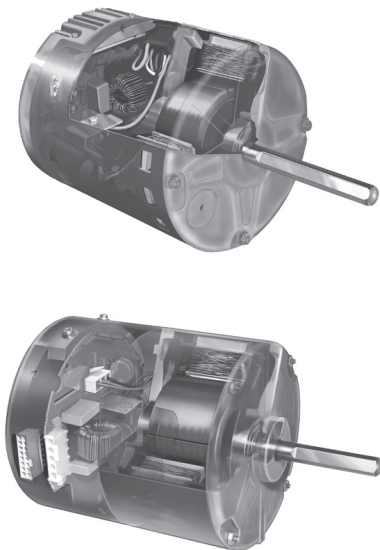

Variable Speed ECM Motor

VHBXB-HW Series

COOLING OR HEAT PUMP
BOILER HEATING



(See P.4 for Model Numbers)

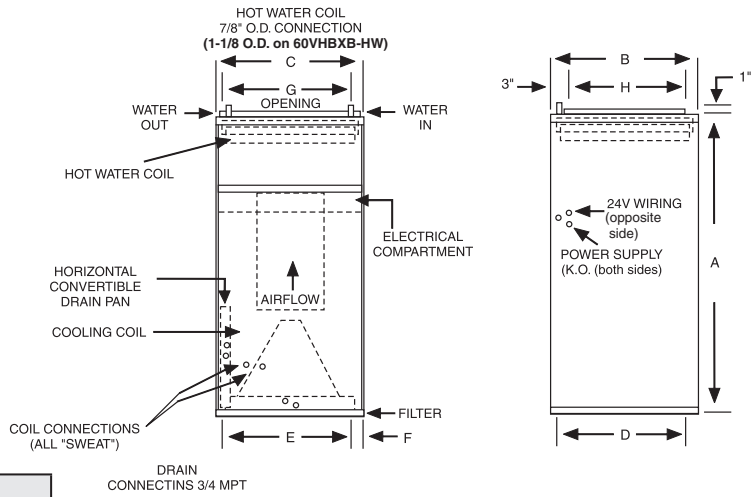

PHYSICAL DIMENSIONS									
UNIT MODEL	A	B	C	D	E	F	G	H	FILTER SIZE
24VHBXB-HW	40	20	20	18-1/2	16	2	18	16	18 X 20 X 1
36VHBXB-HW	42	23	20	21-1/2	16	2	18	19	20 X 22 X 1
48VHBXB-HW	48	28	21-1/4	26-1/4	17-1/4	2	18	24	20 X 25 X 1
60VHBXB-HW	52	28	25-1/4	26-1/4	21-1/4	2	22	24	14 X 24 X 1 (2 required)

COIL CONNECTIONS		
UNIT SIZE	LIQUID	SUCTION
24	3/8	5/8
36	3/8	3/4
46/60	1/2	7/8

HEATING PERFORMANCE DATA									
UNIT MODEL	NOM. COOLING BTUH	HEAT CFM	GPM (HTG)	P.D. (FT. WATER)	BTUH (1000) AT ENTERING WATER TEMPERATURE				
					120°F	140°F	160°F	180°F	
24VHBXB-HW	18,000/ 24,000	800	3	1.13	20.3	28.5	36.6	44.7	
			2	0.51	19.4	27.1	34.9	42.7	
			1	0.13	17.9	25.0	32.2	39.3	
		700	3	1.13	18.8	26.4	33.9	41.5	
			2	0.51	18.0	25.2	32.4	39.6	
			1	0.13	16.7	23.4	30.1	36.8	
	600	3	1.13	17.2	24.1	30.9	37.8		
		2	0.51	16.5	23.0	29.6	36.2		
		1	0.13	15.3	21.4	27.6	33.7		
	36VHBXB-HW	30,000/ 36,000	1200	6	7.55	28.8	40.3	51.8	63.3
				4	3.64	27.0	37.9	48.7	59.5
				2	1.04	23.2	32.4	41.7	50.9
1050			6	7.55	26.6	37.3	48.0	58.6	
			4	3.64	25.1	35.1	45.2	55.2	
			2	1.04	21.6	30.2	38.9	47.5	
900		6	7.55	24.4	34.1	43.9	53.6		
		4	3.64	23.1	32.3	41.5	50.8		
		2	1.04	20.1	28.2	36.2	44.2		
48VHBXB-HW		42,000/ 48,000	1600	6	2.90	47.2	66.0	84.9	103.7
				4	1.40	44.5	62.3	80.0	97.8
				2	0.41	39.8	55.7	71.7	87.6
	1400		6	2.90	43.6	61.0	78.5	95.9	
			4	1.40	41.3	57.8	74.3	90.8	
			2	0.41	37.2	52.1	67.0	81.9	
	1200	6	2.90	39.5	55.4	71.2	87.0		
		4	1.40	37.5	52.5	67.5	82.6		
		2	0.41	34.0	47.6	61.3	74.9		
	60VHBXB-HW	48,000/ 60,000	2000	9	5.15	58.8	82.3	105.9	129.4
				7	3.33	56.4	78.9	101.5	124.1
				5	1.86	52.8	73.9	95.0	116.1
1750			9	5.15	54.4	76.1	97.9	119.6	
			7	3.33	52.3	73.2	94.1	115.0	
			5	1.86	49.2	68.8	88.5	108.2	
1500		9	5.15	49.3	69.1	88.8	108.5		
		7	3.33	47.5	66.5	85.5	104.5		
		5	1.86	44.8	62.7	80.7	98.6		
1250		9	5.15	43.8	61.4	78.9	96.4		
		7	3.33	42.3	59.2	76.1	93.0		
		5	1.86	40.0	56.0	72.0	88.0		

ELECTRICAL DATA				
UNIT MODEL	MOTOR HP (120V)	MOTOR AMPS	MIN. CIR. AMPACITY	MAX. HACR BREAKER
24VHBXB-HW	1/3	4.8	6.0	15
36VHBXB-HW	1/2	7.3	9.1	15
48VHBXB-HW	1	10.5	13.1	15
60VHBXB-HW	1	11.5	14.4	15



For additional sales and technical information on variable speed motors, visit www.thedealertools.com

Digital thermostats for these units must have a "C" terminal.

RECOGNIZED COMPONENT



Intertek

NSF/ANSI

169:2016

NOTES:

(1) Heat BTU is at 65° Entering Air Temperature.

AIRFLOW DATA															
MODEL	OPERATING MODE	THERMOSTAT TERMINALS "X" ENERGIZED TERMINAL						CONTROL BOARD SELECT TAPS							
		Y1	Y2	HUM	G	O	W1	COOL TAP				HEAT TAP			
								A	B	C	D	A	B	C	D
24VHBXB-HW (1.5 / 2 TON)	COOLING														
	SINGLE STAGE		X		X	X		800	720	600	525				
	TWO STAGE	X	X		X	X		560 / 800	500 / 720	420 / 600	370 / 525				
	COOL & DEHUMIDIFY														
	SINGLE STAGE		X	X	X	X		640	575	480	420				
	TWO STAGE	X	X	X	X	X		450 / 640	400 / 575	335 / 480	295 / 420				
	CONTINUOUS BLOWER				X			400	360	300	260				
	HEAT PUMP HEATING														
	SINGLE STAGE		X		X			800	720	600	525				
	TWO STAGE	X	X		X			560 / 800	500 / 720	420 / 600	370 / 525				
HEATING (NON-HT. PUMP)															
HEATING						X						750	680	580	500
36VHBXB-HW (2.5 / 3 TON)	COOLING														
	SINGLE STAGE		X		X	X		1200	1050	950	850				
	TWO STAGE	X	X		X	X		840 / 1200	735 / 1050	665 / 950	595 / 850				
	COOL & DEHUMIDIFY														
	SINGLE STAGE		X	X	X	X		960	840	760	680				
	TWO STAGE	X	X	X	X	X		670 / 960	590 / 840	530 / 760	475 / 680				
	CONTINUOUS BLOWER				X			600	525	475	425				
	HEAT PUMP HEATING														
	SINGLE STAGE		X		X			1200	1050	950	850				
	TWO STAGE	X	X		X			840 / 1200	735 / 1050	665 / 950	595 / 850				
HEATING (NON-HT. PUMP)															
HEATING						X						1150	1000	900	800
48VHBXB-HW	COOLING														
	SINGLE STAGE		X		X	X		1600	1400	1250	1100				
	TWO STAGE	X	X		X	X		1120 / 1600	980 / 1400	875 / 1250	770 / 1100				
	COOL & DEHUMIDIFY														
	SINGLE STAGE		X	X	X	X		1280	1120	1000	880				
	TWO STAGE	X	X	X	X	X		895 / 1280	785 / 1120	700 / 1000	615 / 880				
	CONTINUOUS BLOWER				X			800	700	625	550				
	HEAT PUMP HEATING														
	SINGLE STAGE		X		X			1600	1400	1250	1100				
	TWO STAGE	X	X		X			1120 / 1600	980 / 1400	875 / 1250	770 / 1100				
HEATING (NON-HT. PUMP)															
HEATING						X						1500	1300	1150	1000
60VHBXB-HW	COOLING														
	SINGLE STAGE		X		X	X		2000	1800	1600	1400				
	TWO STAGE	X	X		X	X		1400 / 2000	1260 / 1800	1120 / 1600	980 / 1440				
	COOL & DEHUMIDIFY														
	SINGLE STAGE		X	X	X	X		1600	1440	1280	1120				
	TWO STAGE	X	X	X	X	X		1120 / 1600	1010 / 1440	895 / 1280	785 / 1120				
	CONTINUOUS BLOWER				X			1000	900	800	700				
	HEAT PUMP HEATING														
	SINGLE STAGE		X		X			2000	1800	1600	1400				
	TWO STAGE	X	X		X			1400 / 2000	1260 / 1800	1120 / 1600	980 / 1440				
HEATING (NON-HT. PUMP)															
HEATING						X						1850	1650	1500	1300

Airflow shown are at standard air conditions, dry coil at 240 volts.
Max. ext. static pressure is 0.50" wtr

NOTES:

- The cooling and heating speed taps are factory set on "A".
- The delay profile is factory set on "A" (Arid setting).
- The adjust profile is factory set on "Normal:"
- Adjust profile (+) will increase airflow by 10%, while tap (-) will decrease airflow by 10%

In keeping with its policy of continuous progress and product improvement, First Co. reserves the right to make changes without notice. Maintenance for all First Co. products is available under "Product Maintenance" at www.firstco.com.

Model Numbers:

MODEL SIZE (BTU)	FACTORY INSTALLED TXV'S	
	MODEL (R22 TXV)	MODEL (R410a TXV)
18,000 / 24,000	24VHBXB-HW w/R22 TXV	24VHBXB-HW w/R410a TXV
30,000 / 36,000	36VHBXB-HW w/R22 TXV	36VHBXB-HW w/R410a TXV
42,000 / 48,000	48VHBXB-HW w/R22 TXV	48VHBXB-HW w/R410a TXV
48,000 / 60,000	60VHBXB-HW w/R22 TXV	60VHBXB-HW w/R410a TXV

NOTE:

Expansion valve requirement depends on the selected outdoor unit.
Go to www.firstco.com or contact the factory for assistance.

ACCESSORIES

(field installed)

FREEZE PROTECTOR	
KIT NUMBER	FOR
941-1	18 - 60VHBXB-HW

FLOW CONTROL MODULES	
PART NUMBER	FOR
940-3CV	18 - 48VHBXB-HW
940-2CV	60VHBXB-HW

NOTE:

Flow Control Modules are required when connecting to individual gas water heaters.

3-WAY AIRFLOW

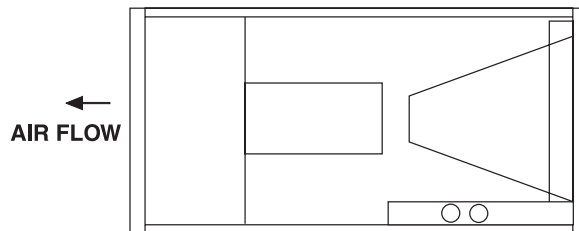
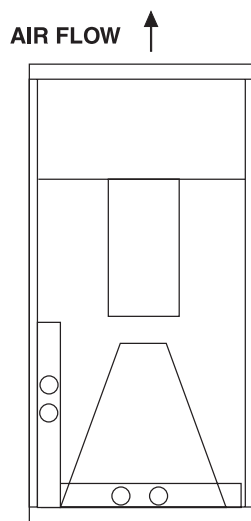

(STANDARD HORIZONTAL POSITION)

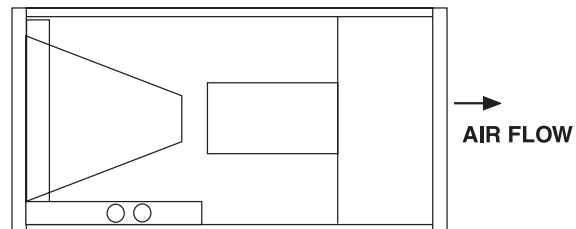

(ALTERNATE HORIZONTAL POSITION)
(FIELD-CONVERTIBLE)