

Feature

- 150# WSP / 600# WOG
- Lead free brass body
- Full port
- Adjustable packing
- FNPT x FNPT
- Threaded ends (ASME B1.20.1-NPT)
- Blow-out proof stem
- Chrome plated ball
- Virgin PTFE seats
- MSS-SP-110
- 500 psi for UL use (1 1/4" & 2")
- CSA certified ANSI Z21.15/CSA 9.1 - 1/2 psi (1/4" - 3")
- CSA certified CGA CR91.002 - 5G (5 psi) (1/4" - 2")
- CSA certified ASME B16.44 - 5G (5 psi) (1/4" - 3")
- CSA certified CSA 3.16 -125 psi (1/4" - 2")
- UL approved (1/4" - 2")
- FM approved (1/2" - 2")
- AB1953, NSF/ANSI 61 & 372 certified



Meet BAA requirement

Pressure/ Temperature rating	
600 psi from 15 °F to 160 °F	150 psi max. at 366 °F

Material

	Part	Material	Specification
1	Body	Lead Free Brass	ASTM B927 C28500
2	End piece	Lead Free Brass	ASTM B927 C28500
3	Ball	Lead Free Brass / Cr plated	ASTM B927 C28500
4	Seat	PTFE	PTFE
5	Stem	Lead Free Brass	ASTM B927 C28500
6	Packing	PTFE	PTFE
7	Packing nut	Brass	ASTM B124 C37700
8	Handle	Steel / Geomet® plated	ASTM A36
9	Handle nut	Steel / Zn plated	ASTM A36
10	Valve info	-	-

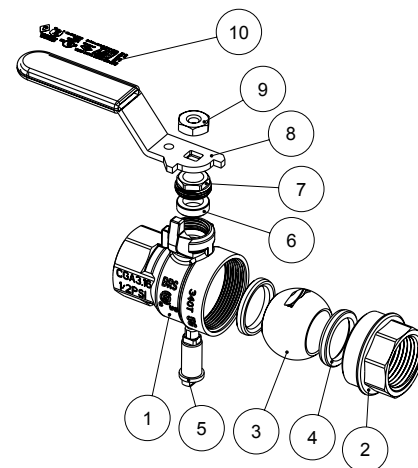

Dimension, Cv, Weight

Size	Φ	A [in]	C [in]	H [in]	L [in]	P [in]	Cv	Wt. [lb]
1/4"	1/4 - 18 NPT	1.73	0.45	1.54	3.19	0.39	8	0.30
3/8"	3/8 - 18 NPT	1.73	0.45	1.54	3.19	0.39	8	0.28
1/2"	1/2 - 14 NPT	2.13	0.55	2.10	3.60	0.59	15	0.50
3/4"	3/4 - 14 NPT	2.45	0.59	2.24	3.60	0.79	30	0.72
1"	1 - 11.5 NPT	2.85	0.71	2.57	4.98	0.98	60	1.16
1 1/4"	1 1/4 - 11.5 NPT	3.28	0.73	2.78	4.98	1.26	110	1.74
1 1/2"	1 1/2 - 11.5 NPT	3.80	0.77	3.27	5.57	1.57	130	2.64
2"	2 - 11.5 NPT	4.34	0.81	3.56	5.57	1.97	360	3.94
2 1/2"	2 1/2 - 8 NPT	5.91	1.18	4.68	11.07	2.56	450	8.16
3"	3 - 8 NPT	6.82	1.22	5.13	11.07	3.15	620	10.94
4"	4 - 8 NPT	7.56	1.32	5.64	11.07	3.94	1200	16.32

