

Installation Instructions

for use by heating contractor

VIESSMANN

Vitocell 300-H

EHA Series

Indirect-fired domestic hot water storage tank

42 USG to 119 USG (160 L to 450 L) capacity

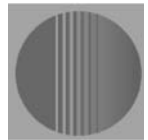

VITOCCELL® 300-H



CAUTION

The heat transfer medium must be water or other non-toxic fluid having a toxicity rating or class of 1, as listed in clinical toxicology of commercial products, 5th edition.

This tank version is not suitable for steam heating applications.

The pressure of the heat transfer medium must be limited to a max. of 30 psig by an approved safety or relief valve.



Product may not be exactly as shown

IMPORTANT

Read and save these instructions for future reference.

Safety, Installation and Warranty Requirements

Please ensure that these instructions are read and understood before commencing installation. Failure to comply with the instructions listed below and details printed in this manual can cause product/property damage, severe personal injury, and/or loss of life. Ensure all requirements below are understood and fulfilled (including detailed information found in manual subsections).

■ **Licensed professional heating contractor**

The installation, adjustment, service and maintenance of this equipment must be performed by a licensed professional heating contractor.

▶ *Please see section entitled "Important Regulatory and Installation Requirements".*



■ **Advice to owner**

Once the installation work is complete, the heating contractor must familiarize the system operator/ultimate owner with all equipment, as well as safety precautions/requirements, shutdown procedure, and the need for professional service annually before the heating season begins.

■ **Product documentation**

Read all applicable documentation before commencing installation. Store documentation near product in a readily accessible location for reference in the future by service personnel.

▶ *For a listing of applicable literature, please see section entitled "Important Regulatory and Installation Requirements".*



■ **Warranty**

Information contained in this and related product documentation must be read and followed. Failure to do so renders the warranty null and void.



 **CAUTION**

The heat transfer medium must either be potable water or contain only substances which are recognized as safe by the U.S. food and drug administration. The pressure of the heat transfer medium must be maintained less than the normal minimum operating pressure of the potable water system.

| | Page |
|-------------------------------|--|
| Introduction | |
| | Safety, Installation and Warranty Requirements.....2 |
| | Licensed professional heating contractor.....2 |
| | Product documentation.....2 |
| | Advice to owner.....2 |
| | Warranty.....2 |
| Safety | |
| | Important Regulatory and Installation Requirements.....4 |
| | Codes.....4 |
| | Mechanical room.....4 |
| | Working on the equipment.....4 |
| | Technical literature.....4 |
| General Information | |
| | About These Instructions.....5 |
| | Product Information.....5 |
| Set-up | |
| | Tank Set-up.....6 |
| | Recommended installation clearances for service access..6 |
| | Transport and Handling.....7 |
| | Multiple Tank Set-up |
| | [only for 92 and 119 USG (350 and 450 L)].....8 |
| Connections | |
| | Orientation and Dimensions.....9 |
| | Control Connections.....10 |
| | Boiler Water Connections (Heat Exchanger Connection)...11 |
| | Individual DHW Tank.....11 |
| | Multiple DHW Tanks |
| | [only for 92 and 119 USG (350 and 450 L)].....12 |
| | Steam Heating Side Connections |
| | [only for 92 and 119 USG (350 and 450 L)].....13 |
| | Individual DHW tank.....13 |
| | Multiple DHW tank.....14 |
| | Domestic Water Connections.....15 |
| | Recirculation Connections.....18 |
| Additional Information | |
| | Pressure Drop Information.....19 |
| | Service.....19 |

Important Regulatory and Installation Requirements

Codes

The installation of indirect-fired hot water storage tanks in boilers and solar system application might be governed by individual local rules and regulations for this type of product, which must be observed. Always use latest editions of codes.

In the Commonwealth of Massachusetts, all plumbing work must be done by a licensed plumber or gas-fitter and for gas installations, all gas piping must be done by a licensed gas-fitter.

Mechanical room

Ensure the mechanical room complies with the requirements of the system design guideline and/or Technical Data Manual (available from your Viessmann sales representative).

The tank must be installed in a mechanical room which is never subject to freezing temperatures.

Ensure water in tank is drained if not in use and danger of freezing exists in the mechanical room.

WARNING

If the heating system itself is to be filled with Glycol or any other antifreeze, the system fill must be of non-toxic or food grade antifreeze. In any circumstance, a non-toxic fluid must be used. Ensure a copy of the Safety Data Sheet (SDS) is supplied to the operator/ultimate owner of the system. The use of Viessmann supplied "Tyfocor-HTL" solar fill is recommended for the solar heating circuit.

Working on the equipment

The installation, adjustment, service, and maintenance of this equipment must be done by a licensed professional heating contractor who is qualified and experienced in the installation, service, and maintenance of hot water heating systems. There are no user serviceable parts on this equipment.

Ensure main power supply to equipment, the heating system, and all external controls has been deactivated. Close main oil or gas supply valve. Take precautions to avoid accidental activation of power during service work.

Technical literature

Literature applicable to all aspects of the Vitocell:

- Technical Data Manual
- Installation Instructions
- Start-up/Service Instructions
- Operating Instructions and User's Information Manual

- ▶ Please carefully read this manual prior to attempting installation. Any warranty is null and void if these instructions are not followed.

This product must be installed observing not only the information and instruction provided in the pertinent product literature (see list on following page), but also all local, provincial/state plumbing and building codes, as they apply to this product and all periphery equipment.

For information regarding other Viessmann System Technology componentry, please reference documentation of the respective product (available from your Viessmann sales representative).

We offer frequent installation and service seminars to familiarize our partners with our products. Please inquire.

- ▶ The completeness and functionality of field supplied electrical controls and components must be verified by the heating contractor. These include low-water cut-offs, flow switches (if used), staging controls, pumps, motorized valves, air vents, thermostats, temperature controls, etc.

- ▶ Leave all literature at the installation site and advise the system operator/ultimate owner where the literature can be found. Contact Viessmann for additional copies.

About These Instructions

 Take note of all symbols and notations intended to draw attention to potential hazards or important product information. These include “WARNING”, “CAUTION”, and “IMPORTANT”. See below.

 **WARNING**

Indicates an imminently hazardous situation which, if not avoided, could result in substantial product/property damage, serious injury or loss of life.

► Warnings draw your attention to the presence of potential hazards or important product information.

 **CAUTION**

Indicates an imminently hazardous situation which, if not avoided, may result in minor injury or product/property damage.

► Cautions draw your attention to the presence of potential hazards or important product information.

IMPORTANT

► Helpful hints for installation, operation or maintenance which pertain to the product.



► This symbol indicates that additional, pertinent information is to be found.



► This symbol indicates that other instructions must be referenced.

Product Information

42 and 53 USG (160 and 200 L) capacity
 Indirect-fired domestic hot water storage tank with one heat exchanger coil for use with hot water heating oilers.

92 and 119 USG (350 and 450 L) capacity
 Indirect-fired domestic hot water storage tank with one heat exchanger coil for use with hot water heating boilers, commercial heating plants, and low-temperature heating systems (larger heating surface).

Tank Set-up

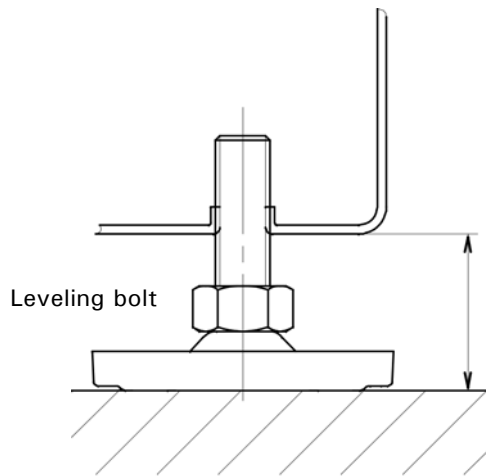

- For narrow passageways, remove lower portion of crating and carry DHW tank to its installation location by means of crating boards mounted on the tank lengthwise.
- Packaged M8 bolts are necessary for the set-up of a multiple tank installation.
- Leave adequate clearance to the wall or other objects enabling easy access to the aquastat (where applicable).
- Locate tank(s) on flooring or foundation capable of supporting the weight of the tank(s) filled with water.
- The tank does not require a special foundation and can be placed directly on the floor. If, for cleanliness purposes, the tank is to be kept off the floor, a foundation can be used for each tank or tank battery.
- A minimum clearance of 17 3/4" (450 mm) must be maintained at the back of the tank for the installation of the sensor well and DHW tank temperature sensor.
- Level tank using leveling bolts on tank frame.

Recommended installation clearances for service access

| Storage capacity | USG (L) | 42 (160) | 53 (200) | 92 (350) | 119 (450) |
|------------------|---|----------|----------|----------|-----------|
| Rear | inches (mm) | 18 (460) | 18 (460) | 18 (460) | 18 (460) |
| Sides | May be reduced if rear pipe connections can be reached with less clearance inches (mm) | 12 (300) | 12 (300) | 12 (300) | 12 (300) |
| Top | inches (mm) | 12 (300) | 12 (300) | 12 (300) | 12 (300) |
| Front | inches (mm) | 24 (600) | 24 (600) | 24 (600) | 24 (600) |

Minimum clearances to combustibles

| Storage capacity | USG (L) | 42 (160) | 53 (200) | 92 (350) | 119 (450) |
|------------------|-------------|----------|----------|----------|-----------|
| All sides | inches (mm) | 0 (0) | 0 (0) | 0 (0) | 0 (0) |

Transport and Handling

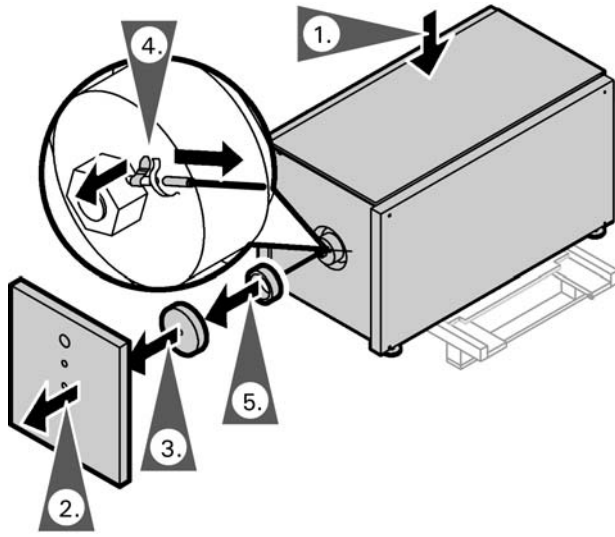

Removing panels

1. Turn tank 90° to sit across its pallet.
2. Carefully unhook front panel.
3. Remove insulation.
4. Remove spring clip and carefully pull sensor of the thermometer out of tank cap.
5. Remove insulation ring.

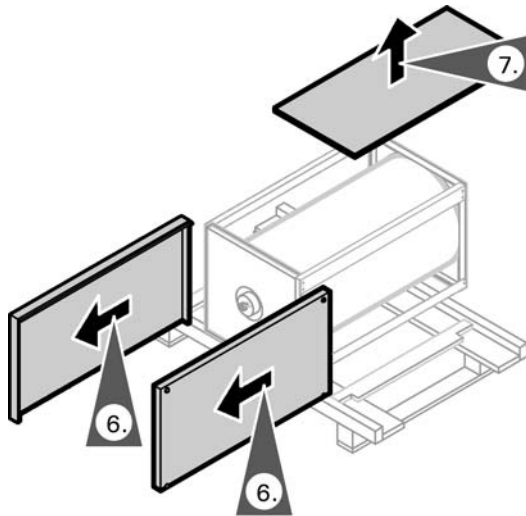

6. Pull side panels forward to remove.
7. Unscrew top panel.

Note: Only for the 92 USG (350 L)

Where access to the boiler room is difficult, remove the front and side panels unscrew the adjustable feet and turn the DHW tank on it's side. This will provide 2 in. less width.

8. Using a flat piece of wood and a rubber mallet, carefully hammer inner front and rear panels off the four corners and remove.
9. Move tank into mechanical room.

Multiple Tank Setup [only for 92 and 119 USG (350 and 450 L)]

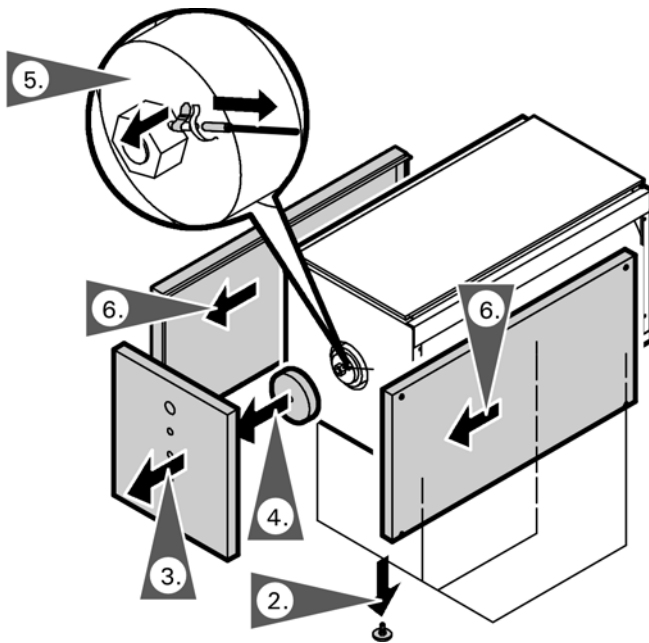

Two tanks, each with 92 USG (350 L) content and up to three tanks, each with 119 USG (450 L) content, may be stacked vertically.

1. Set-up and orient lower tank in its final location.
2. Remove levelling bolts of top tank.
3. Carefully unhook front panel.
4. Remove insulation.
5. Remove spring clip and carefully pull sensor of the thermometer out of tank cap.
6. Pull side panels of top tank forward to remove.

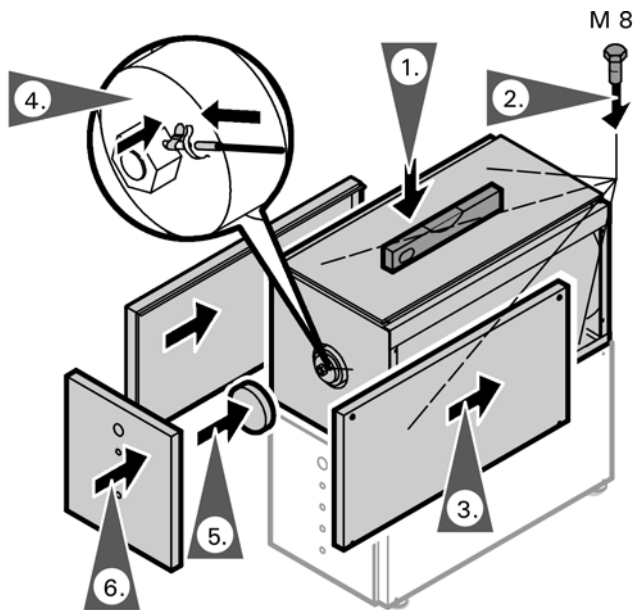

1. Place top tank on top of bottom tank and align.
2. Take packaged M8 bolts, drop in holes of top tank support brackets and fasten to bottom tank support brackets.
3. Reinstall side panels.

IMPORTANT

Install third tank (if applicable) in an identical fashion as the second tank.

4. Fully insert sensor into opening in tank cap and secure using spring-clip.
5. Install insulation.
6. Install front panel.

Orientation and Dimensions

| Storage capacity | USG (L) | 42 (160) | 53 (200) | 92 (350) | 119 (450) | 184 (700) | 238 (900) | 357 (1350) |
|---------------------------------------|---------|----------|----------|----------|-----------|-----------|-----------|------------|
| Number of tanks | | 1 | 1 | 1 | 1 | 2 | 2 | 3 |
| Layout | | | | | | | | |
| Connections (individual Tanks) | | | | | | | | |
| Heating water supply/return | Ø" | 1 | 1 | 1¼ | 1¼ | 1¼ | 1¼ | 1¼ |
| Domestic cold/hot water | Ø" | ¾ | ¾ | 1¼ | 1¼ | 1¼ | 1¼ | 1¼ |
| Pressure and temperature relief valve | Ø" | ¾ | ¾ | 1 | 1¼ | 1 | 1¼ | 1¼ |

42 and 53 USG (160 and 200 L)

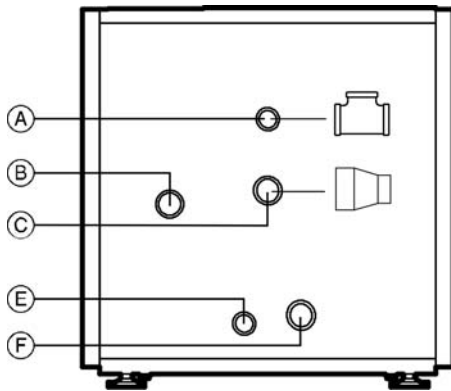

Legend

- (A) Domestic hot water supply, T&P valve (and recirculation tapping) (brass tee ¾ in.)
- (B) Boiler water supply
- (C) Aquastat well (brass reduction coupling 1 - ½ in.)
- (E) Domestic cold water supply
- (F) Boiler water return

92 and 119 USG (350 and 450 L)

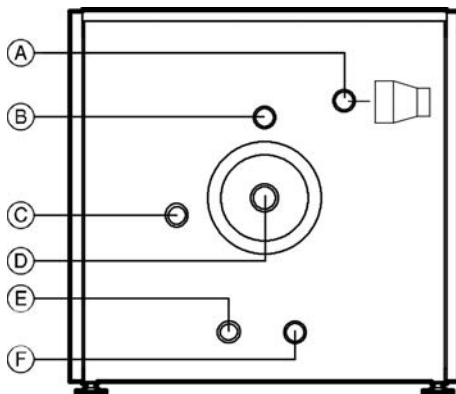

Legend

- (A) T&P valve (and recirculation tapping) (brass reduction coupling 1 - ¾ in. or 1¼ - ¾ in.)
- (B) Domestic hot water
- (C) Boiler water supply
- (D) Aquastat well (brass reduction coupling 1 in. - ½ in.)
- (E) Domestic cold water
- (F) Boiler water return

Control Connections

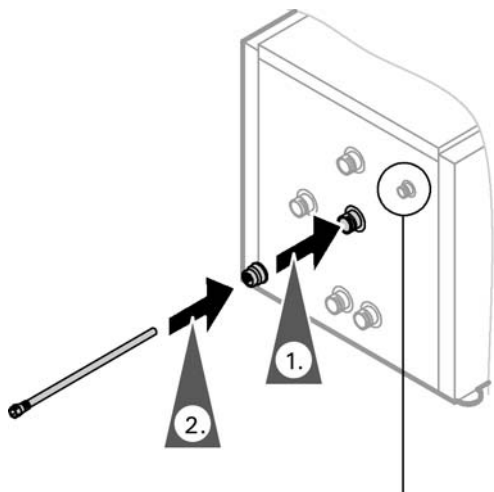

Not present on 42 and 53 USG (160 and 200 L) version

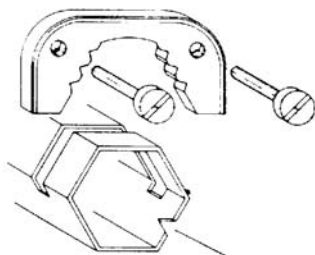
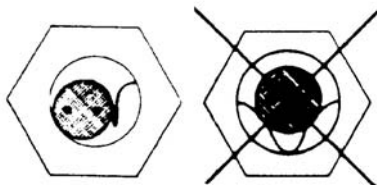
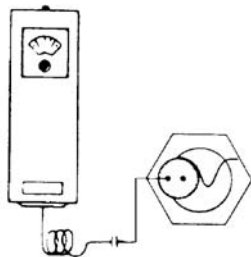

1. Install reducing coupling (included in (Connection Fitting Package). Use approved pipe sealant.
2. Install sensor well using sealant.

Where Vitotronic 200 or 300 is utilized to control DHW production:

3. Insert DHW tank temperature sensor (supplied with Vitotronic 200 or 300) fully and completely into sensor well.

IMPORTANT

Due to the length of the stainless steel well (15" (380 mm)), care must be taken to ensure that the sensing bulb of the limit is inserted and pushed to the end of the stainless steel well.

Where a Vitotronic 100 and a Viessmann Power/Pump Control Module are utilized to control DHW production:

4. Insert the extended capillary of the aquastat (supplied with Viessmann Power/Pump Control Module, not illustrated) fully and completely into sensor well. Mount aquastat inconspicuously on tank paneling. Follow instructions below with regard to sensor and spring clip installation.

...if aquastat is to be mounted remote from the aquastat well:

5. Align sensor bulb with spring clip.
6. Slide assembly into well.
7. The retention spring clip must press the bulb properly to ensure surface contact with the well.

... if aquastat is to be mounted directly on the tank well,

8. Mount aquastat with holding clip supplied directly onto well. Bend capillary tube into groove opening to allow for mounting of aquastat.

! WARNING

To ensure optimum, safe operation, the supplied stainless steel well must be installed. The well diameter is large enough to accommodate a wide variety of sensing bulbs.

Always use spring clip to ensure proper contact of capillary bulb against the stainless steel well for proper sensing/heat transfer!

Boiler Water Connections (Heat Exchanger Connection)

WARNING

The operating aquastat and any secondary high limit aquastat of the tank must be set such that the DHW temperature inside the tank never exceeds 210°F (99°C).

DANGER

Domestic hot water temperatures over 125°F (52°C) can cause severe burns instantly or death from scalds. Children, disabled and elderly are at highest risk of being scalded. Feel water before bathing or showering. Temperature limiting valves are available and must be used where domestic hot water storage tank temperatures exceed 140°F (60°C).

- Maximum working pressure on heat exchanger side up to 220 psig at 392°F (200°C) or a steam pressure of 15 psig at 250°F (121°C)
- Maximum working pressure on DHW water side of up to 150 psig at 210°F (99°C)

Individual DHW Tank

Recommended piping of an individual tank

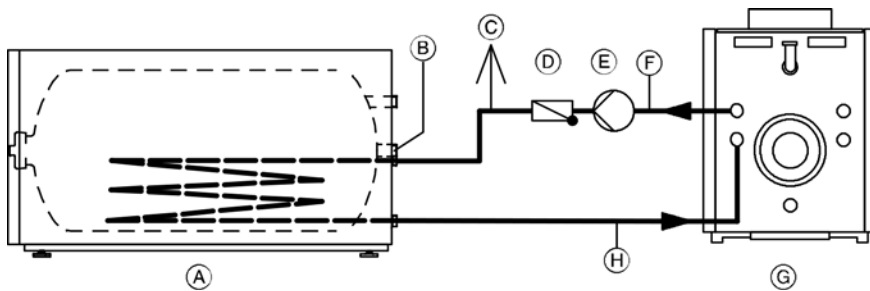

Legend

- (A) Vitocell 300
- (B) Sensor/Operating aquastat well
- (C) Automatic air vent
- (D) Spring-loaded flow-check valve
- (E) Circulation pump
- (F) Boiler water supply
- (G) Boiler
- (H) Boiler water return

IMPORTANT

This is a simplified conceptual drawing only! Piping and necessary componentry must be field verified. Proper installation and functionality in the field is the responsibility of the heating contractor.

1. Pipe together boiler and tank as illustrated. Connections must be accessible for service (use factory supplied adaptors). We recommend using Viessmann Flexible Piping of stainless steel (accessory).
2. For:
 - boiler water supply temperatures over 203°F (95°C) and
 - 92 and 119 USG (350 and 450 L) tanks:
 Remove plastic supply and return grommets (grommets are left threaded).
3. Pipe supply line with an incline and install componentry as follows:
 - flow check valve, to stop gravity circulation of hot water back to the boiler when the boiler temperature is lower than the actual tank temperature
 - automatic air vent, at the high point from the boiler supply to the tank heat exchanger
 - drain valve, on the boiler return piping from the tank heat exchanger coil
 - isolation valve, on the boiler supply and boiler return piping to the tank coil.
4. Protect all domestic hot water drawpoints from excessive water temperatures via a tempering valve.
5. Install DHW tank temperature sensor in sensor well (see page 10).
6. Insulate piping.

Multiple DHW Tanks [only for 92 and 119 USG (350 and 450 L)]

DHW tank battery with 184 or 238 USG (700 or 900 L) (dual cell)

DHW tank battery with 2 x 184 or 2 x 238 USG 2 x (700 or 2 x 900 L) (2 x dual cell)

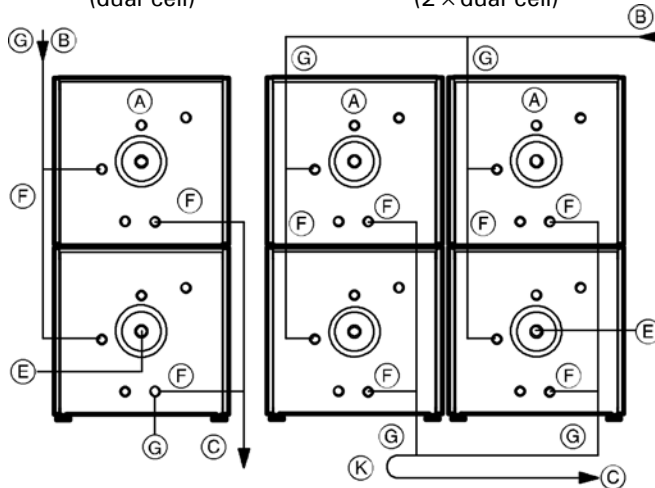

DHW tank battery with 357 USG (1350 L) or 276 USG (900 L) (triple cell)

DHW tank battery with 2 x 357 USG (2 x 1350 L) (2 x triple cell)

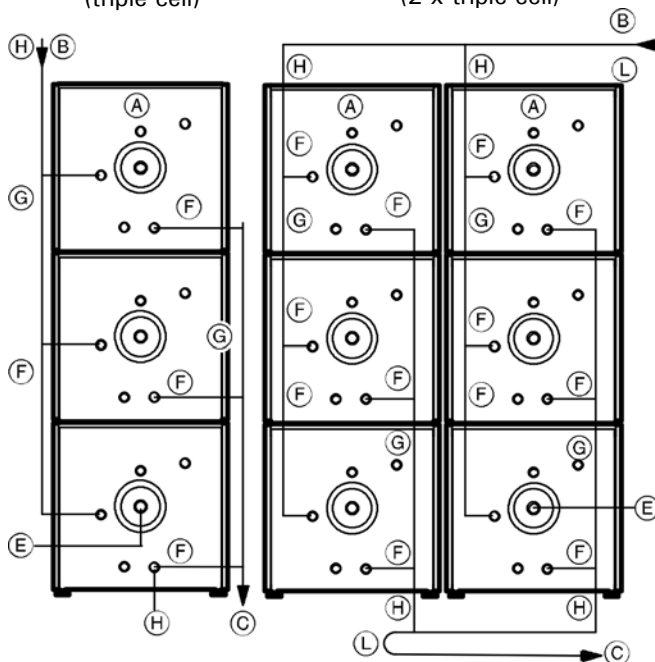

Legend

- (A) Vitocell 300-H
- (B) Boiler water supply
- (C) Boiler water return
- (E) Operating aquastat
- (F) 1 1/4" *1
- (G) 2" *1
- (H) 3" *1
- (K) 4" *1
- (L) 5" *1

*1 Pipe size for boiler supply and return to heat exchanger.

All piping reverse return or use balancing valves.

1. Pipe together boiler (not shown) and tanks as illustrated. Connections must be accessible for service (use factory supplied adaptors).
2. For boiler water supply temperatures over 203°F (95°C):
Remove plastic supply and return grommets (grommets are left threaded).
3. Pipe supply line with an elevation and install an automatic air vent at the highest point.
4. Install boiler sensor in sensor well (see page 10).
5. Insulate piping.

IMPORTANT

The circulation pump is activated by the sensor / operating aquastat and by the control system installed. The operating aquastat should be mounted on the tank which receives the boiler water supply last.

Viessmann recommends the installation of an additional high limit aquastat in the main discharge pipe of the DHW system.

This aquastat should be wired in series with the operating aquastat and should be set approximately 9°F (5°C) higher than the operating aquastat.

WARNING

Install tempering valve(s) to protect against scalding.

WARNING

Do not stack more than three tanks. Stack only tanks of identical size.

Steam Heating Side Connections [only for 92 and 119 USG (350 and 450 L)]

! WARNING

The operating aquastat and any secondary high limit aquastat of the tank must be set such that the DHW temperature inside the tank never exceeds 210°F (99°C).

Do not use Vitocell indirect-fired hot water storage tanks in superheated steam applications.

Use appropriate control strategy.

Control strategy must ensure that the values below are not exceeded.

Install a steam-side control to regulate DHW temperature and ensure that the DHW temperature does not exceed 210°F (99°C).

- Maximum working pressure on heat exchanger side up to 220 psig at 392°F (200°C) or a steam pressure of 15 psig at 250°F (121°C)
- Maximum working pressure on DHW water side of up to 150 psig at 210°F (99°C)

! WARNING

Domestic hot water temperatures over 125°F (52°C) can cause severe burns instantly or death from scalds. Children, disabled and elderly are at highest risk of being scalded.

Feel water before bathing or showering. Temperature limiting valves are available and must be used where domestic hot water storage tank temperatures exceed 140°F (60°C).

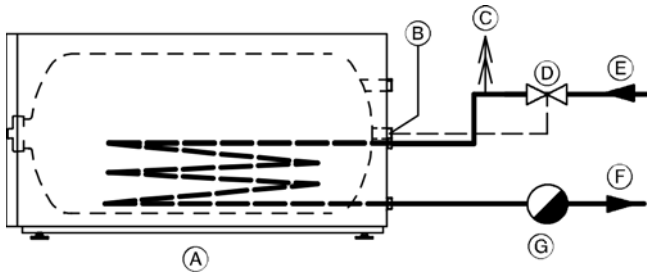

Recommended piping of an individual tank in a steam system

Legend

- (A) Vitocell 300-H
- (B) Sensor/Aquastat well
- (C) Vacuum breaker
- (D) Steam valve
- (E) Steam supply line
- (F) Condensation return line
- (G) Condensate trap

Individual DHW tank

1. Pipe steam and condensate lines as illustrated. Connections must be accessible for service (use factory supplied adaptors).
 2. Remove plastic grommets on tank where condensate lines connect (grommets are left threaded).
 3. Install DHW tank temperature sensor in sensor well; install steam valve.
-  Installation Instructions Control Valve
4. Insulate piping.

! CAUTION

For steam applications, a field supplied 1" T&P valve must be utilized.

Note: For heating water flow temperatures above 203°F (95°C), remove the pipe collars from the pipe outlets of the heating coils (pipe collars have left hand threads).

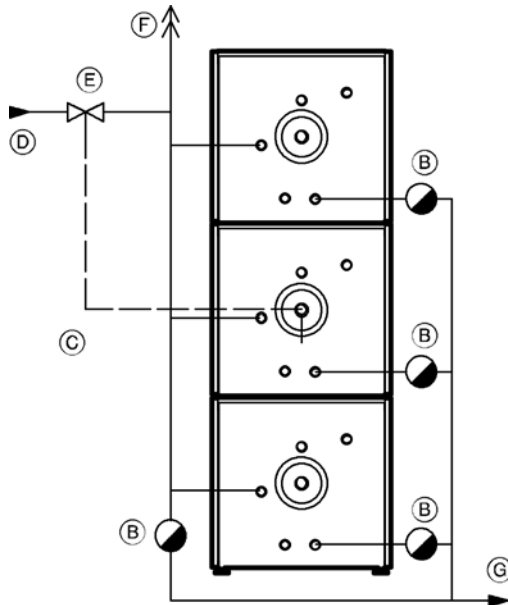
Steam Heating Side Connections [only for 92 and 119 USG (350 and 450 L)] *(continued)*

Recommended piping of a tank battery in a steam system

Legend

- Ⓐ Vitocell 300-H
- Ⓑ Condensate trap
- Ⓒ Sensor/Aquastat well
- Ⓓ Steam supply
- Ⓔ Steam valve
- Ⓕ Vacuum breaker
- Ⓖ Condensate line

Multiple DHW tank

The following installation is also subject to local codes and requirements:

The following installation is also subject to local codes and requirements:

- Install a steam valve and vacuum breaker between steam supply line and each tank.

Install a drain with a condensate trap at the end of the steam supply line to each steam valve.

Install a condensate trap on each heat exchanger outlet before connecting all condensate lines to a common condensate return line.

or

- Install a steam valve in the common steam supply line.

Install a vacuum breaker after the steam valve.

Install a drain with a condensate trap at the end of the steam supply line to each steam valve.

Install a condensate trap on each heat exchanger outlet before connecting all condensate lines to a common condensate return line.

All piping reverse return.

1. Pipe together steam and condensate lines as illustrated. Connections must be accessible for service (use factory supplied adaptors).
2. Remove plastic grommets on each tank where steam and condensate lines connect (grommets are left threaded).
3. Install an approved type high limit aquastat for temperature control of domestic hot water on each tank.
4. Install aquastat temperature sensor in sensor well; install steam valve.
5. Insulate piping.

! WARNING

Do not stack more than three tanks. Stack only tanks of identical size.

IMPORTANT

To ensure uniform heating of domestic hot water within each tank battery, install domestic hot water recirculation as illustrated on page 18.

Cap any unused recirculation connection on each tank. Follow the control and safety recommendations of the respective steam boiler manufacturer.

Domestic Water Connections

DHW tank battery with 184 and 238 USG (700 and 900 L) (dual cell)

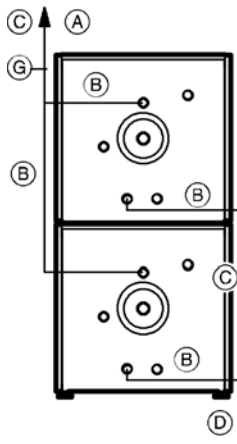

DHW tank battery with 2 x 184 and 2 x 238 USG 2 x (700 and 2 x 900 L) (2 x dual cell)

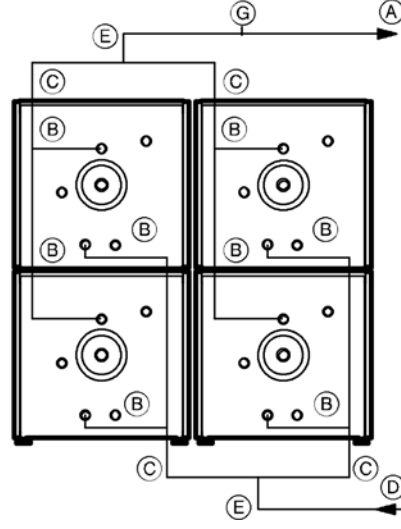

DHW tank battery with 357 USG (1350 L) (triple cell)

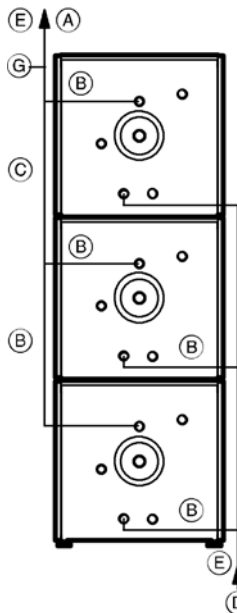

DHW tank battery with 2 x 357 USG 2 x (1350 L) (2 x triple cell)

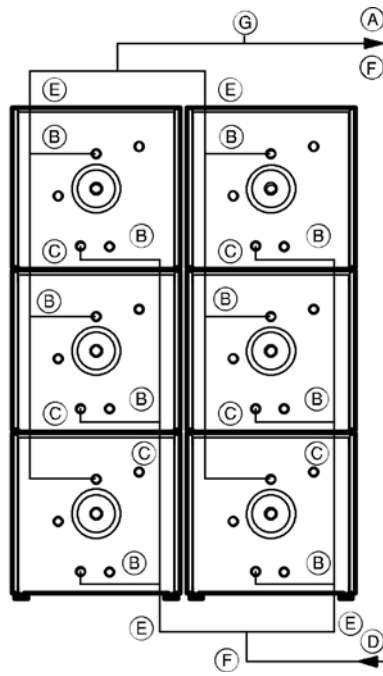

Ensure that local rules and regulations regarding this type of product have been observed.

1. Pipe boiler and tank as illustrated. Connections must be accessible for service (use factory supplied adaptors).
2. Insulate domestic hot water piping and valves.

IMPORTANT

In order to avoid temperature stratification Viessmann recommends the use of a small recirculation pump between the DHW supply point (A) and the DCW supply point (D) in multiple tank arrangements. The recirculation pump will only operate when there is no DHW draw from the tank batteries.

Legend

- | | |
|------------------------|-----------------------------------|
| (A) Domestic hot water | (D) Domestic cold water |
| (B) 1 1/4" *1 | (E) 2" *1 |
| (C) 1 1/2" *1 | (F) 2 1/2" *1 |
| | (G) Secondary high limit aquastat |

*1 Pipe size for domestic cold and hot water piping.

Domestic Water Connections *(continued)*

42 and 53 USG (160 and 200 L) capacity

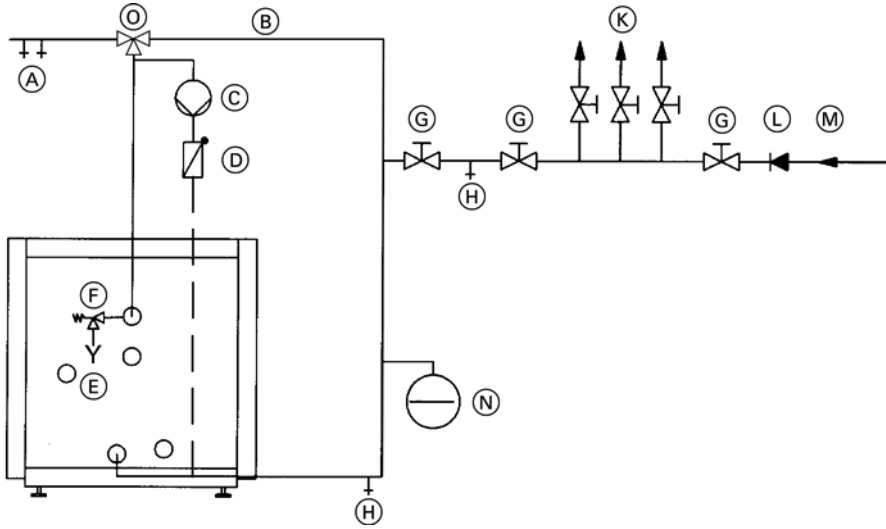

92 and 119 USG (350 and 450 L) capacity

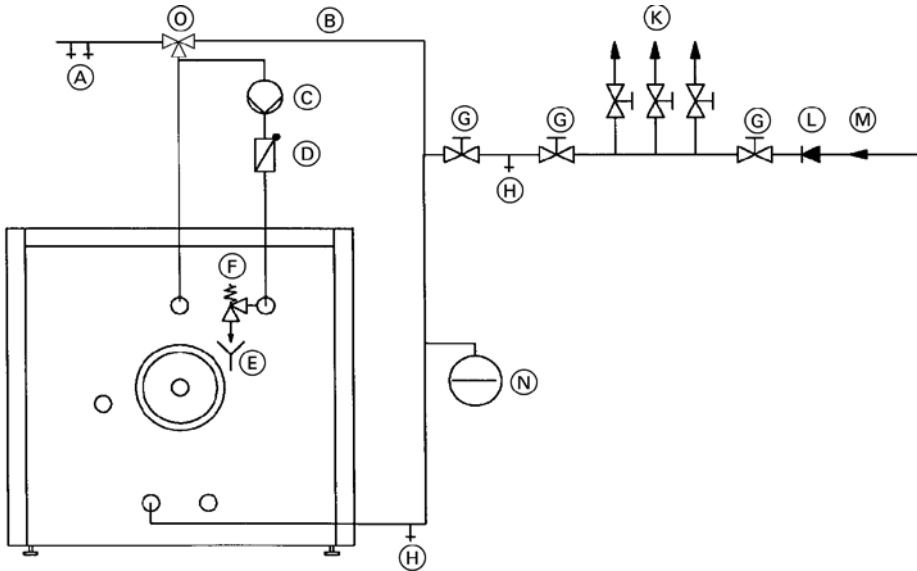

Legend

- (A) Domestic hot water supply
- (B) DHW recirculation line
- (C) recirculation pump
- (D) Spring loaded check valve
- (E) Discharge pipe
- (F) Pressure and temperature relief valve
- (G) Shut-off valve
- (H) Drain
- (K) Domestic cold water supply lines
- (L) Back-flow preventer
- (M) Domestic cold water inlet
- (N) Precharged expansion tank
(required where back-flow preventer is installed; check local plumbing codes and requirements)

Domestic Water Connections *(continued)*

Always ensure the use of approved devices. Safety devices include the following components:

- Isolation valves
- Drain valve
- Pressure reducing valve where required by local jurisdiction
- Drinking water filter where required by local jurisdiction
- Backflow preventer
Where backflow preventers are required, a domestic water expansion tank installation is required in the cold water inlet piping before the cold water enters the tank. The backflow device must be installed according to the manufacturer’s installation instructions. Observe local codes and regulations.
- Tempering valve
A tempering valve must be field installed where storage tank (domestic hot water temperature) exceeds local restricted temperatures or 140°F (60°C). Check code requirements.

IMPORTANT

In situations where a booster pump is used to maintain DHW pressure, Viessmann strongly recommends the installation of an oversized large expansion tank to ensure longer, less frequent pump cycles with less severe pressure gradients. If possible, use flexible piping before and after booster pump to isolate system piping from vibration and shocks.

- Temperature and pressure relief valve
A temperature and pressure relief valve (T&P valve) is supplied with the tank. The heating contractor must install the valve on each tank in a method meeting code requirements.
If local codes require a different relief valve, consult Viessmann Manufacturing for a substitute valve. The tank is approved for a maximum operating pressure of 150 psig.
The T&P valve supplied with the tank is tested under ANSI Z21.22 Code for Relief Valves and Automatic Gas Shut-off Devices for Hot Water Supply Systems.

| | |
|-----------------------------------|-------------------------------------|
| T&P Valve set pressure | 150 psig |
| ASME pressure steam rating | see ratings marked on the T&P valve |
| CSA discharge capacity | 205 MBH |
| Relief temperature | 210°F (99°C) |
| Inlet thread | ¾" male |
| Outlet thread | ¾" female |

Proper installation of the T&P valve shall include all of the following:

- The T&P valve shall be installed in the pipe connection point marked TPV in the tank instruction manual.
- The discharge line from the T&P valve shall be ¾ in. (1.9 cm) Ø and run to a safe place of discharge approximately 1 ft. (30 cm) above the floor, close to a floor drain.
- The discharge line must be as short as possible and pitch downward from the T&P valve and terminate plain not threaded.

WARNING
The discharge line for the T&P valve must be oriented to prevent scalding of attendants.

- Do **not** route discharge line directly to the outdoors.
- Do **not** install any type of valve or restriction of any kind between the tank and the T&P valve, or between the T&P valve and the discharge line outlet.

WARNING
The valve test lever must be operated at least once per year by the owner to ensure that waterways are clear. A licensed professional heating contractor shall reinspect the T&P valve at least once every three years. Failure to inspect can result in unsafe temperature or pressure build-up, which can result in death, serious injury or substantial product/property damage.

Recirculation Connections

Connection of a recirculation system in a multiple tank installation for systems utilizing boilers or remote heating plants without low temperature boiler return water and for steam heating operation with 15 psi and one recirculation line.

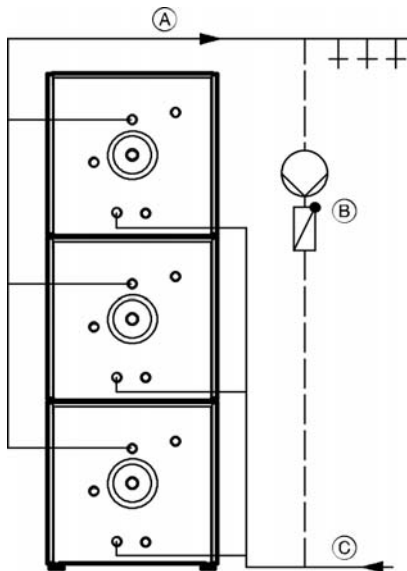

Legend

- (A) Domestic hot water
- (B) Recirculation circuit
- (C) Domestic cold water

- Pipe domestic hot water supply piping with tank as illustrated. Connections must be accessible for service (use factory supplied adaptors). Connection sizes are provided in section entitled Orientation and Dimensions on page 9.
- Install recirculation pump, flow-check valve and recirculation timer (for shut-down during off-hours where feasible) on the recirculation piping side.
- Gravity circulation of the recirculation system is restricted due to the upward-curved domestic hot water discharge piping inside the tank.
- Connect tank battery to existing recirculation piping. Cap off unused recirculation connections of individual tanks.

Saving Energy

A timer on the recirculation pump reduces the heat loss significantly in commercial applications during times when no or reduced demand for domestic hot water occurs.

Connection of a recirculation system in a multiple tank installation for remote heating plants with low temperature boiler return water limit and/or for multiple recirculation lines.

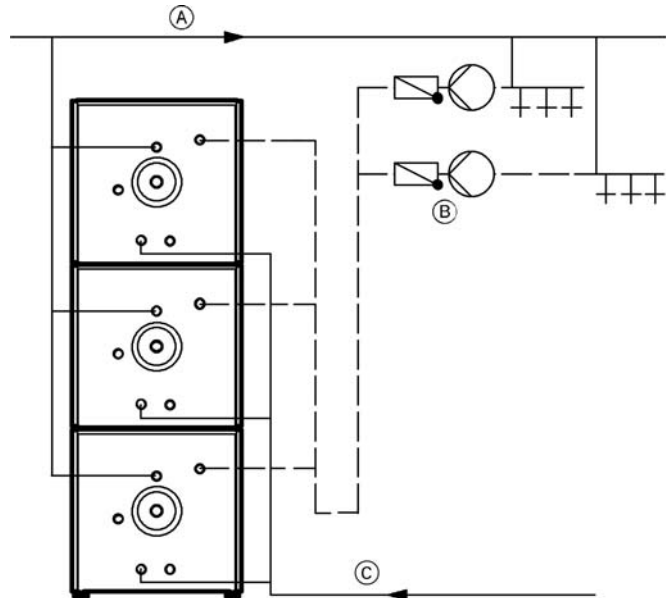

Legend

- (A) Domestic hot water
- (B) Recirculation circuit
- (C) Domestic cold water

Recirculation tapping

[only for 92 and 119 USG (350 and 450 L)]

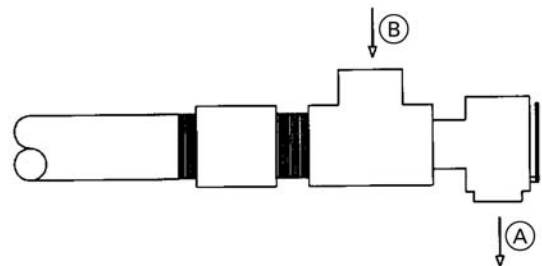

Legend

- (A) 42 and 53 USG (160 and 200 L) storage capacity
- (B) 92 and 119 USG (350 and 450 L) storage capacity

The recirculation tapping on the tank is also the opening for mounting the temperature and pressure relief valve (T&P valve).

If this opening is utilized for recirculation, extend the stainless steel nipple on the tank with a brass tee (field supplied) of the same size as the stainless steel nipple diameter to accommodate both connections.

Pressure Drop Information

Pressure drop on domestic hot water side (secondary circuit)

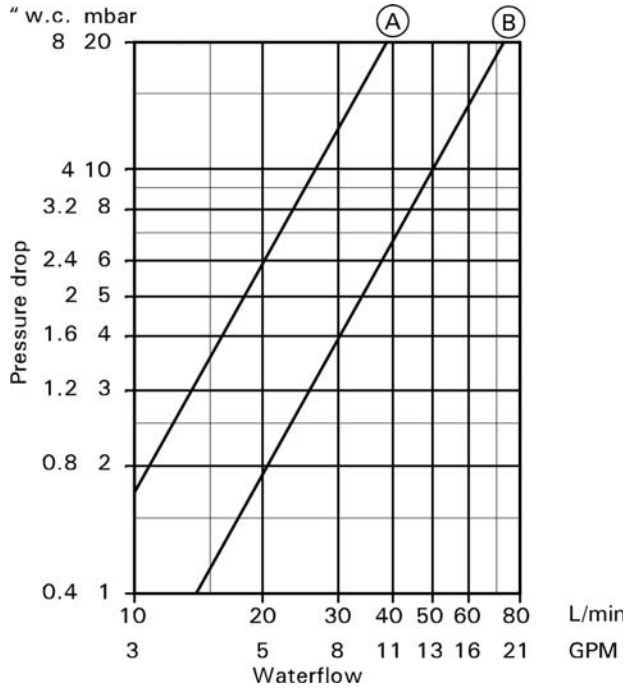

Legend

- Ⓐ 42 and 53 USG (160 and 200 L) storage capacity
- Ⓑ 92 and 119 USG (350 and 450 L) storage capacity

Pressure drop on heating water side (primary circuit)

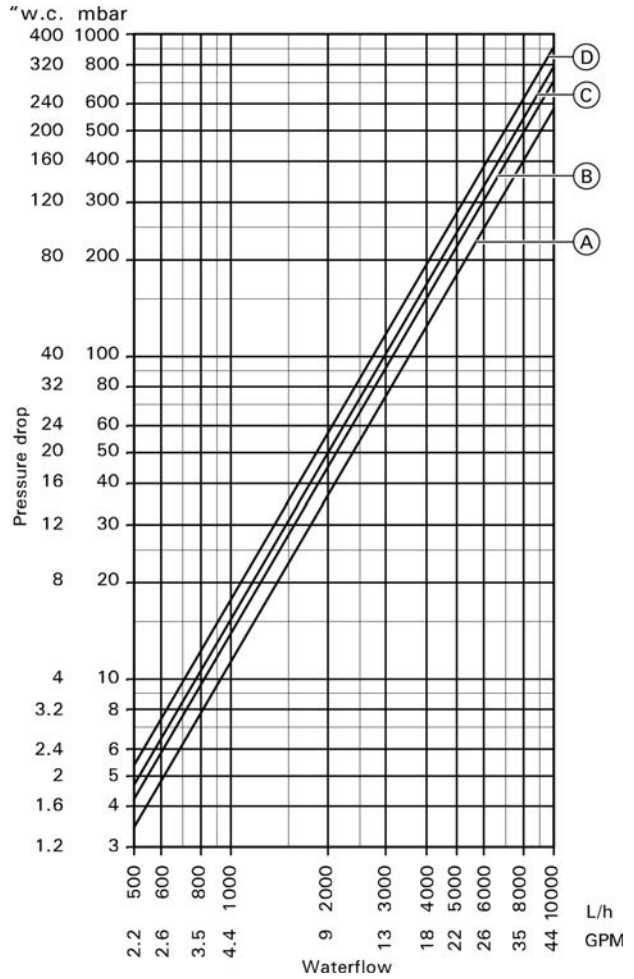

Legend

- Ⓐ 42 USG (160 L) storage capacity
- Ⓑ 53 USG (200 L) storage capacity
- Ⓒ 92 USG (350 L) storage capacity
- Ⓓ 119 USG (450 L) storage capacity

Service



For start-up information refer to the Start-up/Service Instructions DHW Tank.

For a listing of applicable Viessmann literature, please see Important Regulatory and Installation Requirements.

1. File all Parts Lists, Operating and Service instructions in the Service Binder.
2. Install a protective hanging case near the boiler and store the Service Binder in this location.

Printed on environmentally friendly
(recycled and recyclable) paper.



Technical information subject to change without notice.

Viessmann Manufacturing Company Inc.
750 McMurray Road
Waterloo, Ontario • N2V 2G5 • Canada
TechInfo Line 1-888-484-8643
1-800-387-7373 • Fax (519) 885-0887
www.viessmann.ca • info@viessmann.ca

Viessmann Manufacturing Company (U.S.) Inc.
45 Access Road
Warwick, Rhode Island • 02886 • USA
TechInfo Line 1-888-484-8643
1-800-288-0667 • Fax (401) 732-0590
www.viessmann-us.com • info@viessmann-us.com