

Technical Data Manual

Model Nos. and pricing: see Price List

VIESSMANN

VITOCELL 300-H

EHA Series

Indirect-fired domestic hot water storage tank
42 to 119 USG (160 to 450 L)



Product may not be exactly as shown

Vitocell 300-H

EHA Series

Horizontal indirect-fired domestic hot water storage tank made of high-grade stainless steel



Benefits

Fully hygienic, efficient and economical domestic hot water production with DHW tanks of high-grade stainless steel – horizontal version.

Benefits at a glance:

- Corrosion-resistant tank of high-grade SA 240-316 Ti stainless steel offers a long service life.
- Fully hygienic due to high quality homogeneous stainless steel surfaces.
- The high-alloy material is immune to cracking or peeling. The tank stays hygienic and requires only minimum service.
- The entire water content is heated by a 1 ¼" (32 mm) diameter stainless steel heat exchanger surface which extends to the bottom of the tank.
- Certified to CSA Low Lead Content Certification Program; including US Safe Drinking Water Act, NSF/ANSI 372 as well as other applicable US State requirements.
- The positioning of the tubular heat exchanger coil further ensures that 82 to 97% of the tank volume can be drawn at constant water temperature.
- The stainless steel heat exchanger coil is self-venting towards the top and self-draining towards the bottom, therefore not susceptible to reduced heat transfer due to air lock or sediment deposits.
- Standby losses minimized by 2 ¼" (58 mm) highly effective, foamed-in-place HCFC-free insulation.
- Easy transport into mechanical room due to low weight and compact construction.

Cross Section

2 1/4" (57 mm) thick
foamed-in-place
HCFC-free insulation

Tank is constructed of
high-grade SA 240-316
Ti stainless steel

Non-finned, stainless steel,
tubular heat exchanger coil
extends to tank bottom – the
entire water volume is heated
ensuring no cold spots where
bacteria growth could occur

Inspection port/
clean-out opening

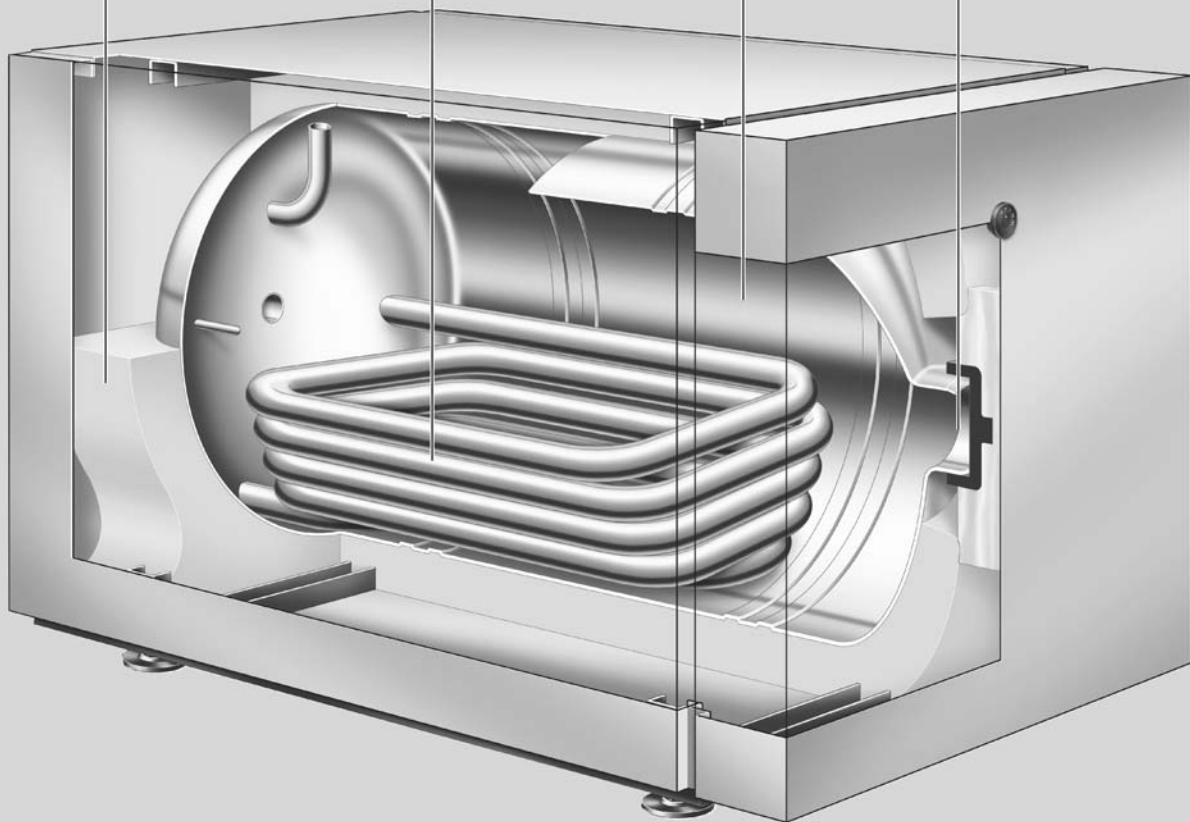

Product may not be exactly as shown

Technical Data

For domestic hot water heating applications which utilize hot water heating boilers

Suitable for heating systems with:

- max. working pressure on heat exchanger side up to 220 psig at 392°F (200°C)
- Only for 92 and 119 USG (350 and 450 L) saturated steam 15 psig at 250°F (121°C)
- max. working pressure on DHW water side of up to 150 psig at 210°F (99°C)

Storage capacity		USG (L)	42 (160)	53 (200)	92 (350)	119 (450)
Recovery rates *1 with a temperature rise of water from 50 to 140°F (10 to 60°C) and heating water supply temperature of at the supply flow rate stated below	194°F (90°C)	MBH (kW) GPH (L/h)	96 (28) 126 (482)	113 (33) 150 (568)	239 (70) 318 (1204)	280 (82) 372 (1410)
	176°F (80°C)	MBH (kW) GPH (L/h)	78 (23) 108 (396)	85 (25) 114 (430)	174 (51) 234 (877)	212 (62) 282 (1066)
	158°F (70°C)	MBH (kW) GPH (L/h)	51 (15) 66 (258)	58 (17) 78 (292)	116 (34) 156 (585)	133 (39) 180 (671)
Supply flow rate for the recovery rates stated		GPM (m ³ /h)	13.2 (3.0)	22.0 (5.0)	22.0 (5.0)	22.0 (5.0)
Recovery rates *5 with a temperature rise of the domestic hot water from 50 to 113°F (10 to 45°C) a steam pressure of and a max. steam velocity of 164 ft/s (50 m/s)	7½ psig	MBH (kW) GPH (L/h)	--	--	283 (83) 539 (2039)	283 (83) 539 (2039)
	15 psig	MBH (kW) GPH (L/h)	--	--	358 (105) 682 (2580)	358 (105) 682 (2580)
Standby losses *2		MBH/24h	4.0	4.2	6.0	6.6
Overall dimensions						
Overall depth		in. (mm)	42¼ (1072)	48¾ (1236)	62½ (1590)	65 (1654)
Overall width		in. (mm)	25¼ (640)	25¼ (640)	32¾ (830)	35¾ (910)
Width without enclosure		in. (mm)	--	--	30¼ (768) *3*4	32 (810) *4
Overall height		in. (mm)	25¾ (654)	25¾ (654)	31 (786)	35 (886)
Weight						
Tank with insulation		lb (kg)	168 (76)	185 (84)	379 (172)	421 (191)
Heating water content (heat exchanger pipe coil)		USG (L)	1.8 (7)	2.1 (8)	3.4 (13)	4.2 (16)
Heat exchanger surface area		ft ² (m ²)	9.36 (0.87)	9.7 (0.9)	18.3 (1.7)	22.6 (2.1)
Connections						
Heating water supply/return	∅" (male thread)		1	1	1¼	1¼
Domestic cold/hot water	∅" (male thread)		¾	¾	1¼	1¼
Temp. and press. relief valve	∅" (male thread)		¾	1	1	1¼

- *1 When planning for the recovery rate as stated or calculated, allow for the corresponding circulation pump. The stated recovery rate is only achieved when the rated output of the boiler is equal to or greater than that stated under "Recovery rates". Please also refer to the corresponding sizing chart at the end of this manual.
- *2 Measured values are based on a room temperature of 68°F (20°C) and a domestic hot water temperature of 149°F (65°C) and can vary by ±5%.
- *3 To overcome mechanical room access problems, the front panel with thermometer and side panels can be removed, the adjustable feet unscrewed, and the Vitocell 300-H turned on its side.
- *4 This is the net width of the Vitocell 300-H after removing the outer casing to ease problems of access into the mechanical room.
- *5 Only for 92 and 119 USG (350 and 450 L) saturated steam 15 psig at 250°F (121°C)

42 and 53 USG (160 and 200 L)

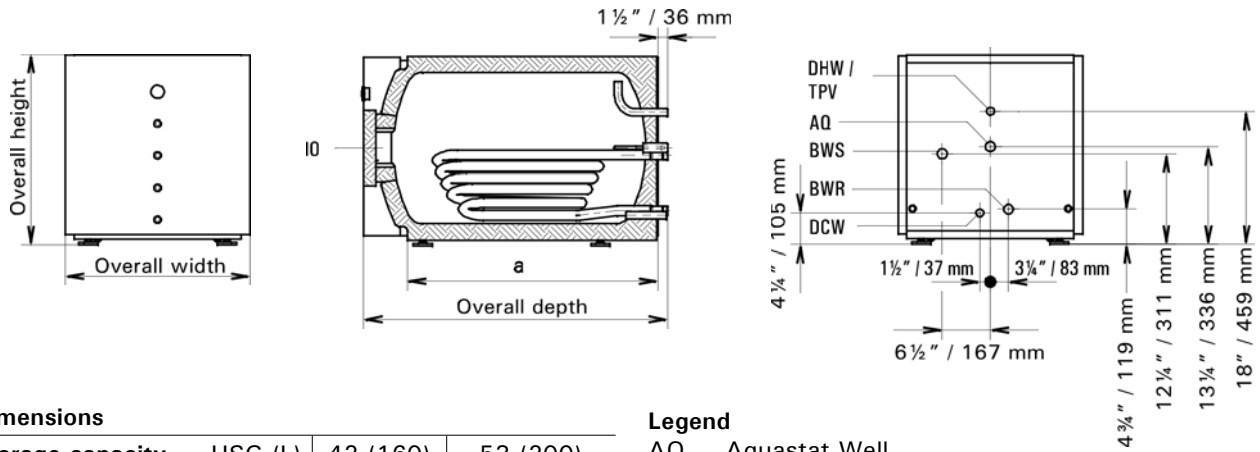

Dimensions

Storage capacity	USG (L)	42 (160)	53 (200)
a	in. (mm)	34 (866)	40 1/2 (1030)

Legend

- AQ Aquastat Well
- BWR Boiler Water Return
- BWS Boiler Water Supply
- DCW Domestic Cold Water
- DHW Domestic Hot Water
- IO Inspection and Clean-out Opening
- TPV Temperature and Pressure Relief Valve

92 and 119 USG (350 and 450L)

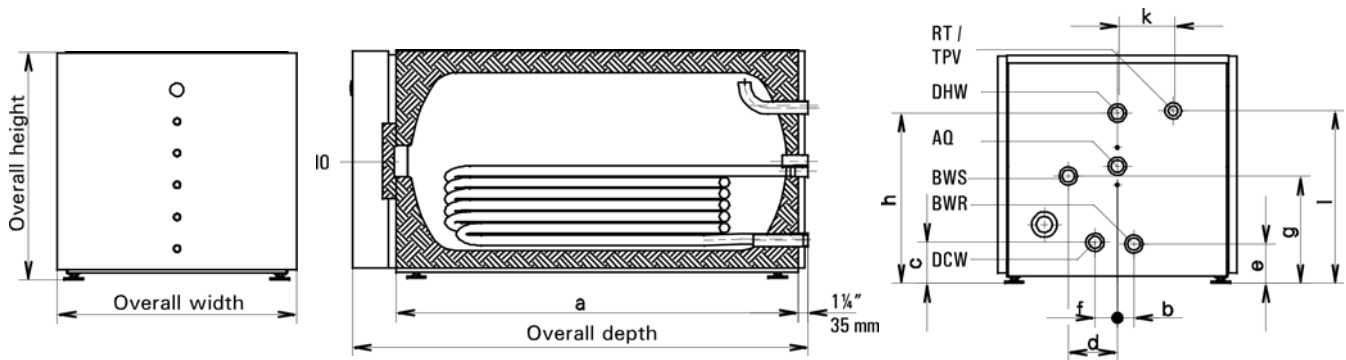

Dimensions

Storage capacity	USG (L)	92 (350)	119 (450)
a	in. (mm)	55 (1397)	57 1/2 (1461)
b	in. (mm)	2 1/4 (57)	2 3/4 (72)
c	in. (mm)	5 1/2 (139)	5 1/2 (138)
d	in. (mm)	6 3/4 (170)	8 (203)
e	in. (mm)	5 1/4 (133)	5 1/4 (137)
f	in. (mm)	3 (78)	3 (78)
g	in. (mm)	14 1/2 (368)	16 (409)
h	in. (mm)	23 (586)	25 (636)
k	in. (mm)	7 1/2 (193)	9 (226)
l	in. (mm)	23 1/2 (594)	26 3/4 (677)

Legend

- AQ Aquastat Well
- BWR Boiler Water Return
- BWS Boiler Water Supply
- DCW Domestic Cold Water
- DHW Domestic Hot Water
- IO Inspection and Clean-out Opening
- TPV Temperature and Pressure Relief Valve
- RT Recirculation tapping

Pressure Drop

Pressure drop on heating water side (primary circuit)

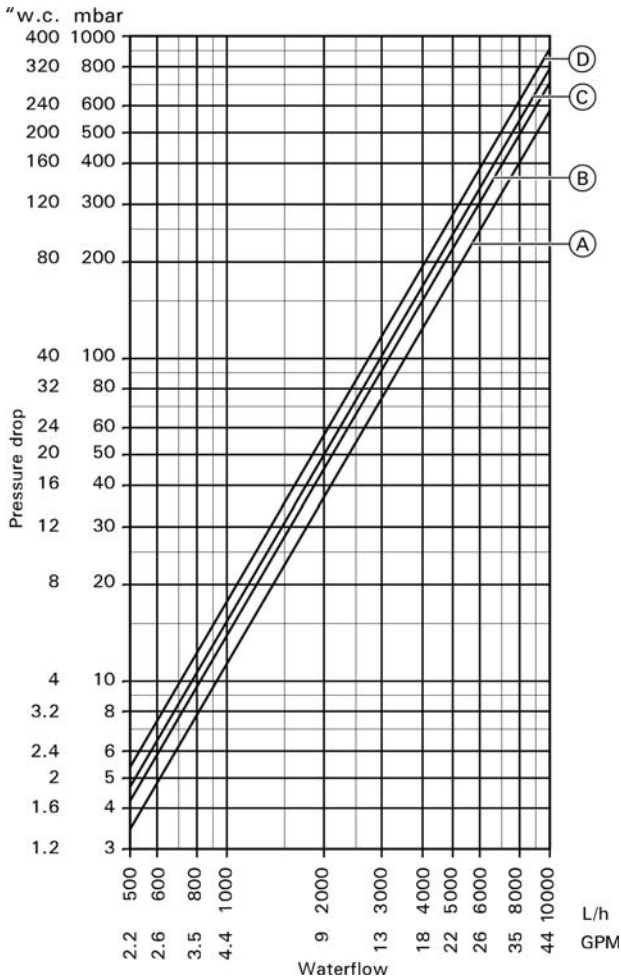

Legend

- Ⓐ 42 USG (160 L) storage capacity
- Ⓑ 53 USG (200 L) storage capacity
- Ⓒ 92 USG (350 L) storage capacity
- Ⓓ 119 USG (450 L) storage capacity

Domestic hot water draw rate

Storage tank contents heated to 140°F (60°C), boiler not reheating

Storage Capacity	USG (L)	42 (160)	53 (200)	92 (350)	119 (450)
Domestic hot water draw rate	GPM (L/min)	2.6 (10)	2.6 (10)	4.0 (15)	4.0 (15)
Domestic hot water draw	USG (L)	40 (150)	49 (185)	83 (315)	116 (440)
Water with t = 140°F (60°C) (constant)					
Percentage Tank Volume		94%	93%	90%	97%

Heat-up time

The stated heating times are achieved when the maximum recovery rate of the domestic hot water tank is made available at the respective supply temperature and with a domestic hot water rise from 50 to 140°F (10 to 60°C).

Storage Capacity	USG (L)	42 (160)	53 (200)	92 (350)	119 (450)
Heating water supply temperature	194°F (90°C)	19	18	15	20
	176°F (80°C)	26	25	20	26
	158°F (70°C)	34	32	31	40

Pressure drop on domestic hot water side (secondary circuit)

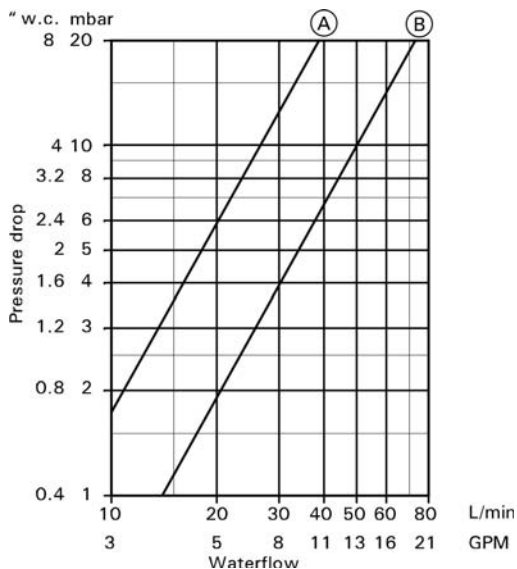



Legend

- Ⓐ 42 and 53 USG (160 and 200 L) storage capacity
- Ⓑ 92 and 119 USG (350 and 450 L) storage capacity

Multiple Tank Installation

Three possible combinations are shown below as examples.
 Note the maximum number of tank units which may be stacked upon one another.

Total capacity of tank battery	USG (L)	184 (700)	238 (900)	357 (1350)	
Number of storage tanks		2	2	3	
Storage capacity per tank	USG (L)	92 (350)	119 (450)	119 (450)	
Layout	Max. number of tanks which may be stacked on top of each other.				
					
Recovery rates *1	194°F (90°C)	MBH (kW) GPH (L/h)	478 (140) 636 (2408)	560 (164) 744 (2820)	839 (246) 1116 (4230)
with a temperature rise of the domestic hot water from 50 to 140°F (10 to 60°C) and heating water supply temperature of at the supply flow rate stated below	176°F (80°C)	MBH (kW) GPH (L/h)	348 (102) 462 (1754)	423 (124) 564 (2132)	635 (186) 864 (3198)
	158°F (70°C)	MBH (kW) GPH (L/h)	232 (68) 312 (1170)	266 (78) 354 (1342)	399 (117) 534 (2013)
Supply flow rate for the recovery rates stated	GPM (m ³ /h)		44 (10)	44 (10)	66 (15)
Recovery rates with a temperature rise of the domestic hot water from 50 to 113°F (10 to 45°C) a steam pressure of and a max. steam velocity of 164 ft/s (50 m/s)	7½ psig	MBH(kW) GPH (L/h)	566 (166) 1080 (4078)	566 (166) 1080 (4078)	850 (249) 1620 (6117)
	15 psig	MBH (kW) GPH (L/h)	717 (210) 1362 (5160)	717 (210) 1362 (5160)	1075 (315) 2046 (7740)
Standby losses *2	MBH/24 h		12.0	13.2	19.8

***1** When planning for the recovery rate as stated or calculated, allow for the corresponding circulation pump. The stated recovery rate is only achieved when the rated output of the boiler is equal to or greater than that stated under "Recovery rates".
***2** Measured values are based on a room temperature of 68 °F (20 °C) and a domestic hot water temperature of 149 °F (65 °C) and can vary by ±5%.

Installation of additional aquastat(s)

⚠ WARNING

In a multiple tank installation, it is recommended that an additional high limit aquastat be installed in the common domestic hot water supply header to the system. This aquastat should be wired in series to the operating aquastat on the tank battery. The setting on this additional high limit aquastat should be approximately 9°F (5°C) higher than the operating high limit.

Ensure that temperature tempering valve(s) is/ are installed if the domestic hot water storage tank temperature exceeds 140°F (60°C) to protect from scalding. Consult plumbing codes and authorities for local requirements.

Multiple Tank Installation *(continued)*

Quick recovery (over 10-minute period)

Domestic hot water rise from 50 to 113°F (10 to 45°C)

Storage Capacity	USG (L)	92 (350)	119 (450)	119 (450)
Battery storage capacity	USG (L)	184 (700)	240 (900)	360 (1350)
Number of tanks		2	2	3
Heating water supply temperature		Quick recovery (over 10-minute period)		
194°F (90°C)				
USG /10 min (L) /10 min		219 (830)	317 (1200)	433 (1640)
176°F (80°C)				
USG /10 min (L) /10 min		219 (830)	300 (1137)	408 (1545)
158°F (70°C)				
USG /10 min (L) /10 min		203 (769)	277 (1050)	378 (1430)

Max. domestic hot water draw rate (over 10-minute period)

Domestic hot water rise from 50 to 113°F (10 to 45°C)

Storage Capacity	USG (L)	92 (350)	119 (450)	119 (450)
Battery storage capacity	USG (L)	184 (700)	240 (900)	360 (1350)
Number of tanks		2	2	3
Heating water supply temperature		Quick recovery (over 10-minute period)		
194°F (90°C)				
USG /10 min (L) /10 min		21.9 (83)	31.7 (120)	43.3 (164)
176°F (80°C)				
USG /10 min (L) /10 min		21.9 (83)	30.1 (114)	40.7 (154)
158°F (70°C)				
USG /10 min (L) /10 min		20.3 (77)	27.7 (105)	37.8 (143)

Domestic hot water draw rate

Storage tank content heated to 140°F (60°C), boiler not reheating

Storage Capacity	USG (L)	92 (350)	119 (450)	119 (450)
Battery storage capacity	USG (L)	184 (700)	240 (900)	360 (1350)
Number of tanks		2	2	3
Domestic hot water draw rate	GPM (L/min)	7.9 (30)	7.9 (30)	7.9 (30)
Domestic hot water draw	USG (L)	166 (630)	232 (880)	349 (1320)
Water with t = 140°F (60°C) (constant)				
Percentage Tank Volume		90%	97%	97%

Standard equipment

Vitocell 300-H, with 42 to 119 USG (160 to 450 L) capacity Domestic hot water tank of high-alloy stainless steel with PUR Foam insulation with:

- adjustable leveling feet.

The following is packed separately and attached to the crate:

- installation fittings package
- temperature and pressure relief valve
- sensor well with insulation
- thermometer
- Installation Instructions, Start-up/Service Instructions and Operating Instructions.

Electrostatically powder coated sheet metal enclosure panel in a Vitosilver finish.

Connections

Domestic hot water connections

42 and 53 USG (160 and 200 L) capacity

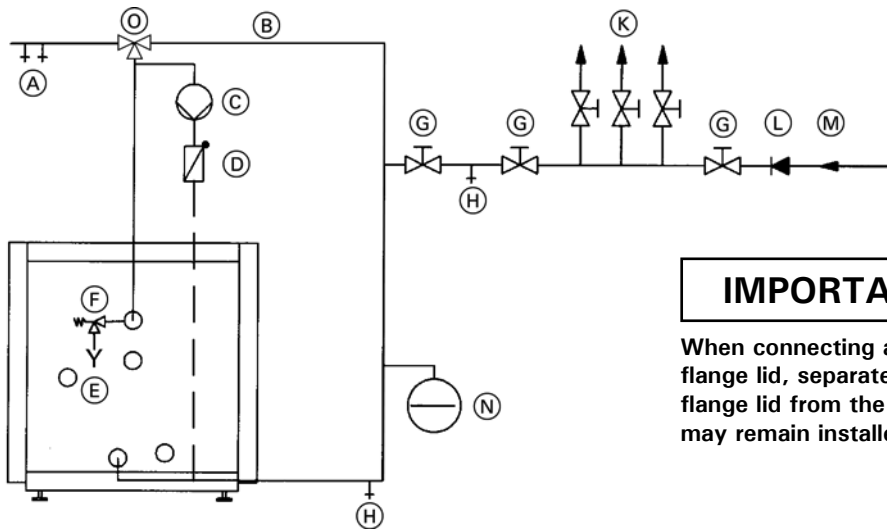

IMPORTANT

When connecting an externally powered anode to the top flange lid, separate the magnesium anode in the bottom flange lid from the grounding cable. The magnesium anode may remain installed.

Legend

- (A) Domestic hot water supply
- (B) DHW recirculation line
- (C) DHW recirculation pump
- (D) Spring loaded flow check valve
- (E) Discharge pipe of temperature and pressure relief valve
- (F) Temperature and pressure relief valve
- (G) Shut-off valve
- (H) Drain
- (K) Domestic cold water supply lines
- (L) Backflow preventer
- (M) Domestic cold water inlet
- (N) Precharged expansion tank
(required where backflow preventer is installed;
check local plumbing codes and requirements)
- (O) Thermostatic mixing valve/anti-scald

Domestic hot water connections

92 and 119 USG (350 and 450 L) capacity

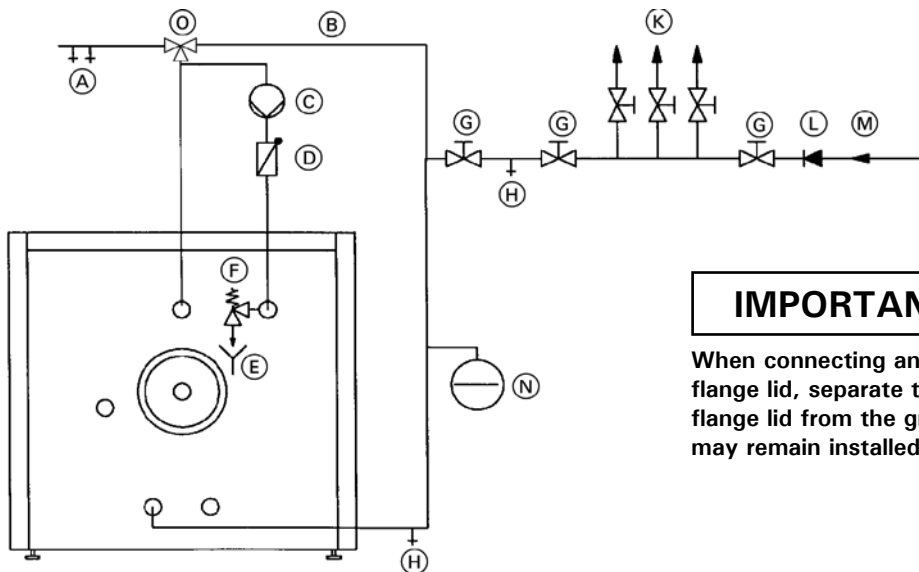

IMPORTANT

When connecting an externally powered anode to the top flange lid, separate the magnesium anode in the bottom flange lid from the grounding cable. The magnesium anode may remain installed.

Sensor Well

Vitocell 300-H, 42 and 53 USG (160 and 200 L)

The sensor well is welded into the DHW tank.

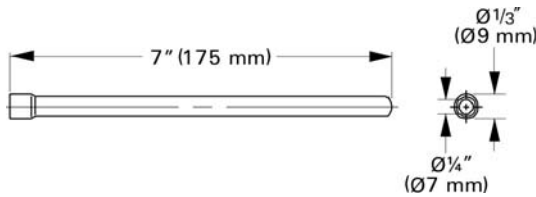

Vitocell 300-H, 92 and 119 USG (350 and 450 L)

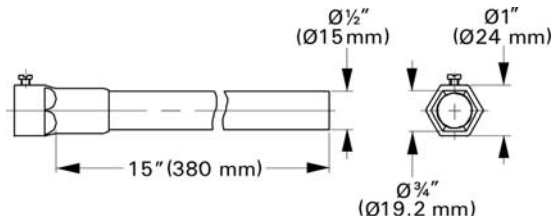

WARNING

To ensure optimum, safe operation, the supplied stainless steel well must be installed. The well diameter is large enough to accommodate a wide variety of sensing bulbs. Always use spring clip to ensure proper contact of capillary bulb against the stainless steel well for proper sensing/heat transfer!

Heating water supply temperatures over 230°F (110°C)

For these operating conditions, an approved high limit safety aquastat must be installed to limit the domestic hot water temperature to 203°F (95°C) in the tank.

Recirculation tapping

The recirculation tapping on the Vitocell-H 300 is also the opening for mounting the temperature and pressure relief valve.

If this opening is utilized for recirculation, extend the stainless steel nipple on the tank with a brass tee of the same size as the stainless steel nipple \varnothing to accommodate both connections; see installation the instructions.

Temperature and pressure relief valve

A temperature and pressure relief valve (T&P relief valve) is supplied with the tank. The heating contractor must install the valve on each tank in a method meeting code requirements. If local codes require a different relief valve, substitute the manufacturer's supplied valve. The tank is approved for 100 psig where a CRN is required. Maximum operating pressure is 150 psig. For steam applications, a field supplied 1" T&P valve must be utilized.

T&P Valve	100 psig (where CRN is required)	150 psig
ASME pressure steam rating	see ratings marked on T&P valve	
CSA temperature steam rating	205 MBH	
Relief temperature	210°F (99°C)	
Inlet thread	3/4" male	
Outlet thread	3/4" female	

Warranty excerpt

Our warranty for domestic hot water tanks states that the water heated should be of drinking water quality and that any water treatment equipment in use must function correctly.

If the product has been improperly installed or misapplied by the installer, contractor or final user, Viessmann accepts no responsibility for damage howsoever caused and reserves the right to withdraw the product warranty. In order to qualify for product warranty, strict adherence to the installation and service manuals must be observed. In the event that Viessmann non-approved components are utilized, Viessmann reserves the right to withdraw all expressed or implied warranties without written notice.

The water to be heated with the Vitocell must be drinking (potable) water quality. If the tank is used to heat other media, the warranty will be null and void. Damage resulting from excessive pressure or temperature is clearly not the responsibility of Viessmann.

The amount of chloride and sulfate acceptable to the tank is limited. In areas where high concentrations of chloride and sulfate are present in drinking water, please consult Viessmann for directions.

For full warranty details, please read the product warranty card.

Backflow preventers

Where backflow preventers are required, a domestic water expansion tank installation is recommended in the cold water inlet piping before the cold water enters the Vitocell. For the backflow device, observe local plumbing codes and regulations.

Continuous Flow Capacity Chart

42 USG (160 L) capacity

Curve (A) Domestic hot water 40 to 140°F (4 to 60°C)

Curve (B) Domestic hot water 40 to 176°F (4 to 80°C)

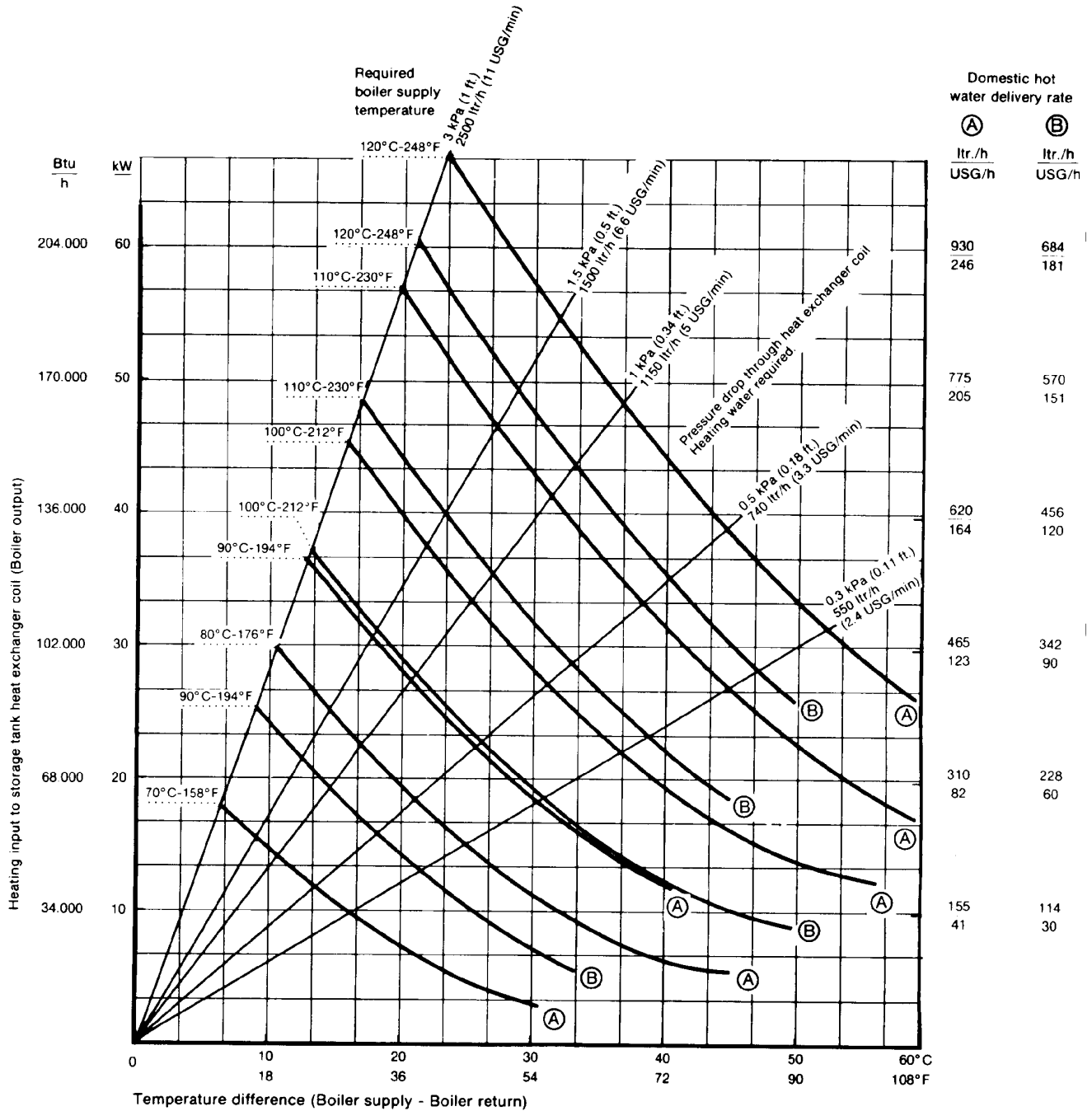

Continuous Flow Capacity Chart *(continued)*

53 USG (200 L) capacity

Curve **(A)** Domestic hot water 40 to 140°F (4 to 60°C)

Curve **(B)** Domestic hot water 40 to 176°F (4 to 80°C)

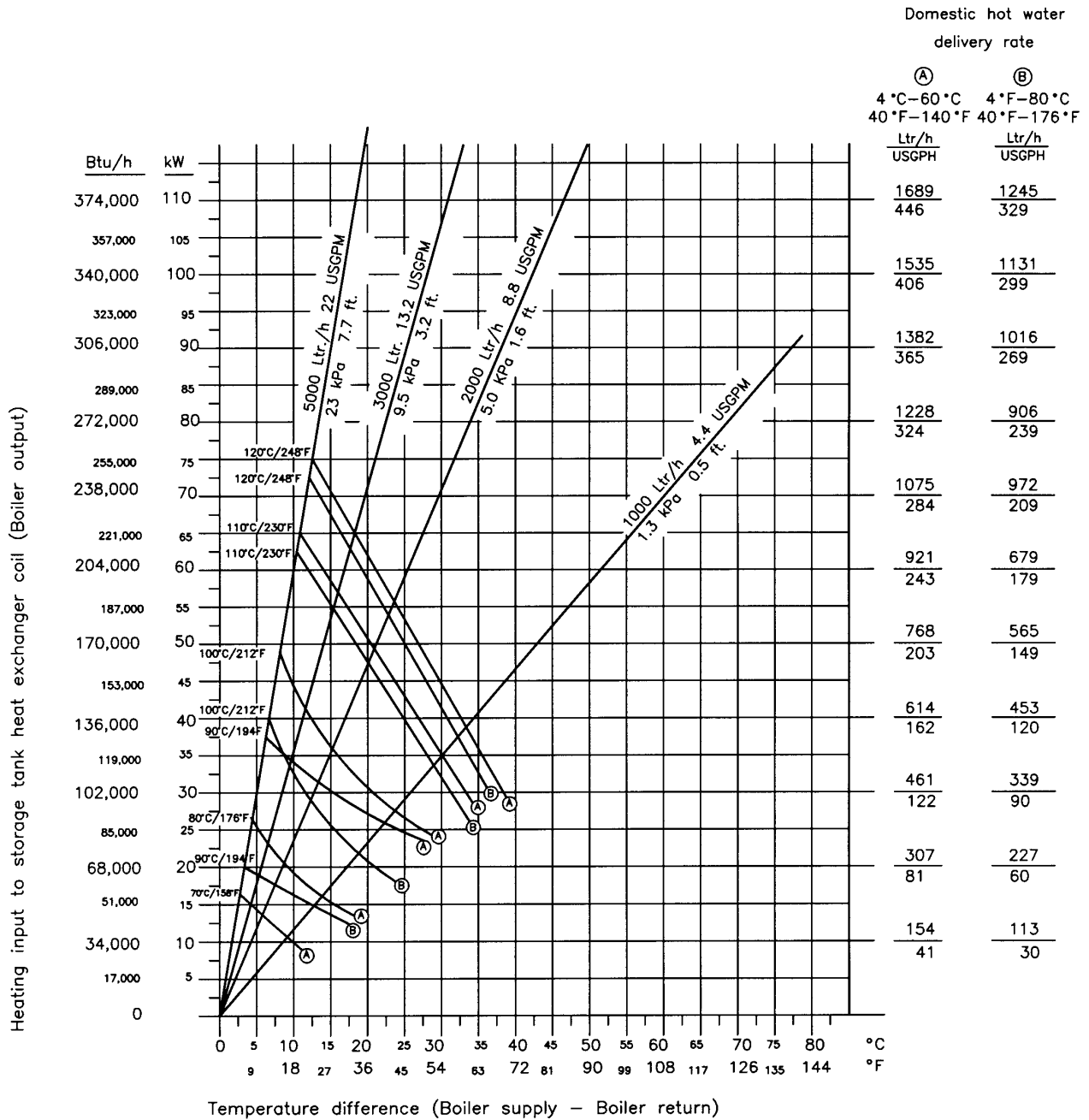

Continuous Flow Capacity Chart (continued)

92 USG (350 L) capacity

Curve (A) Domestic hot water 40 to 140°F (4 to 60°C)

Curve (B) Domestic hot water 40 to 176°F (4 to 80°C)

Domestic hot water delivery rate

(A)	(B)
4°C - 60°C	4°C - 80°C
40°F - 140°F	40°F - 176°F
Ltr/h USGPH	Ltr/h USGPH

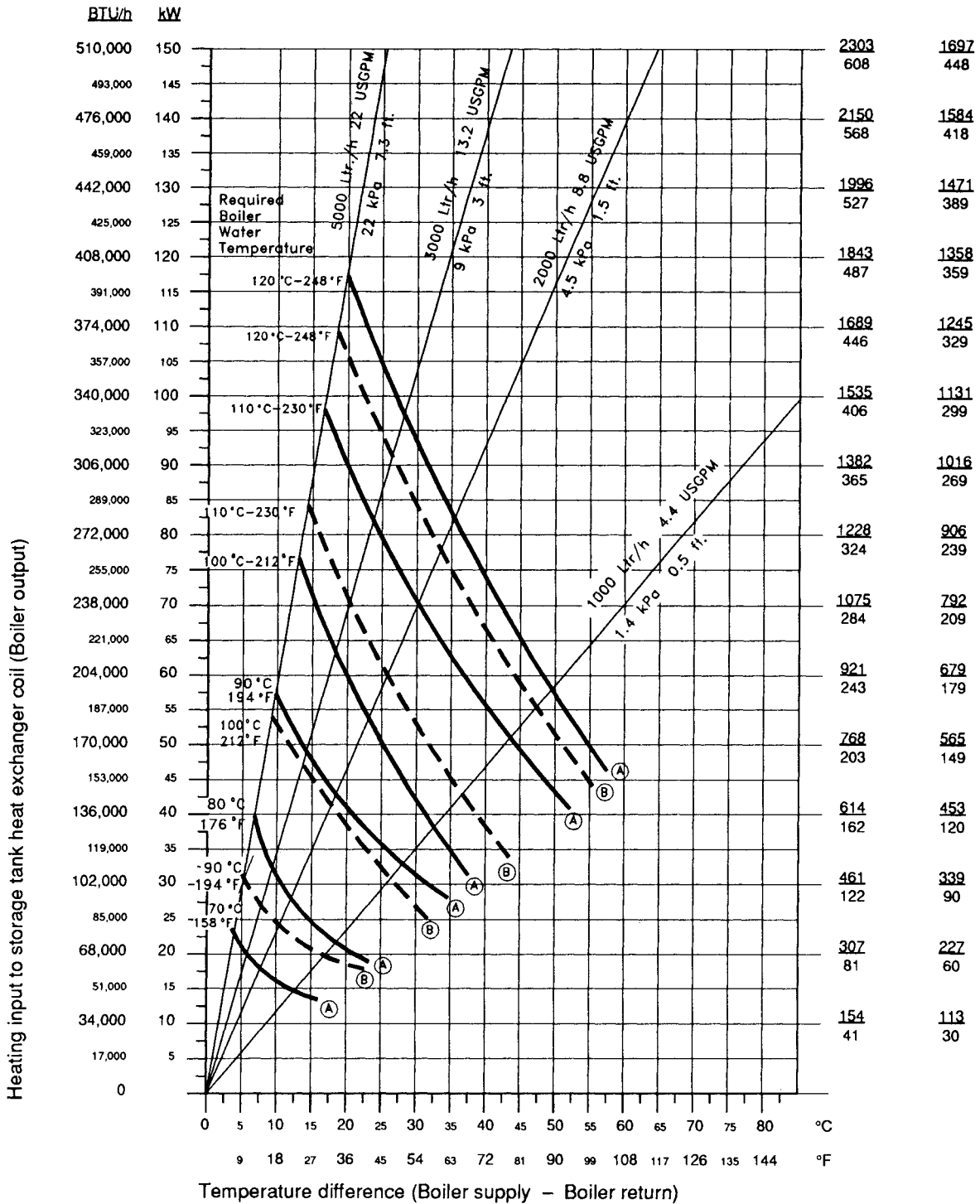

Continuous Flow Capacity Chart *(continued)*

119 USG (450 L) capacity

Curve (A) Domestic hot water 40 to 140°F (4 to 60°C)

Curve (B) Domestic hot water 40 to 176°F (4 to 80°C)

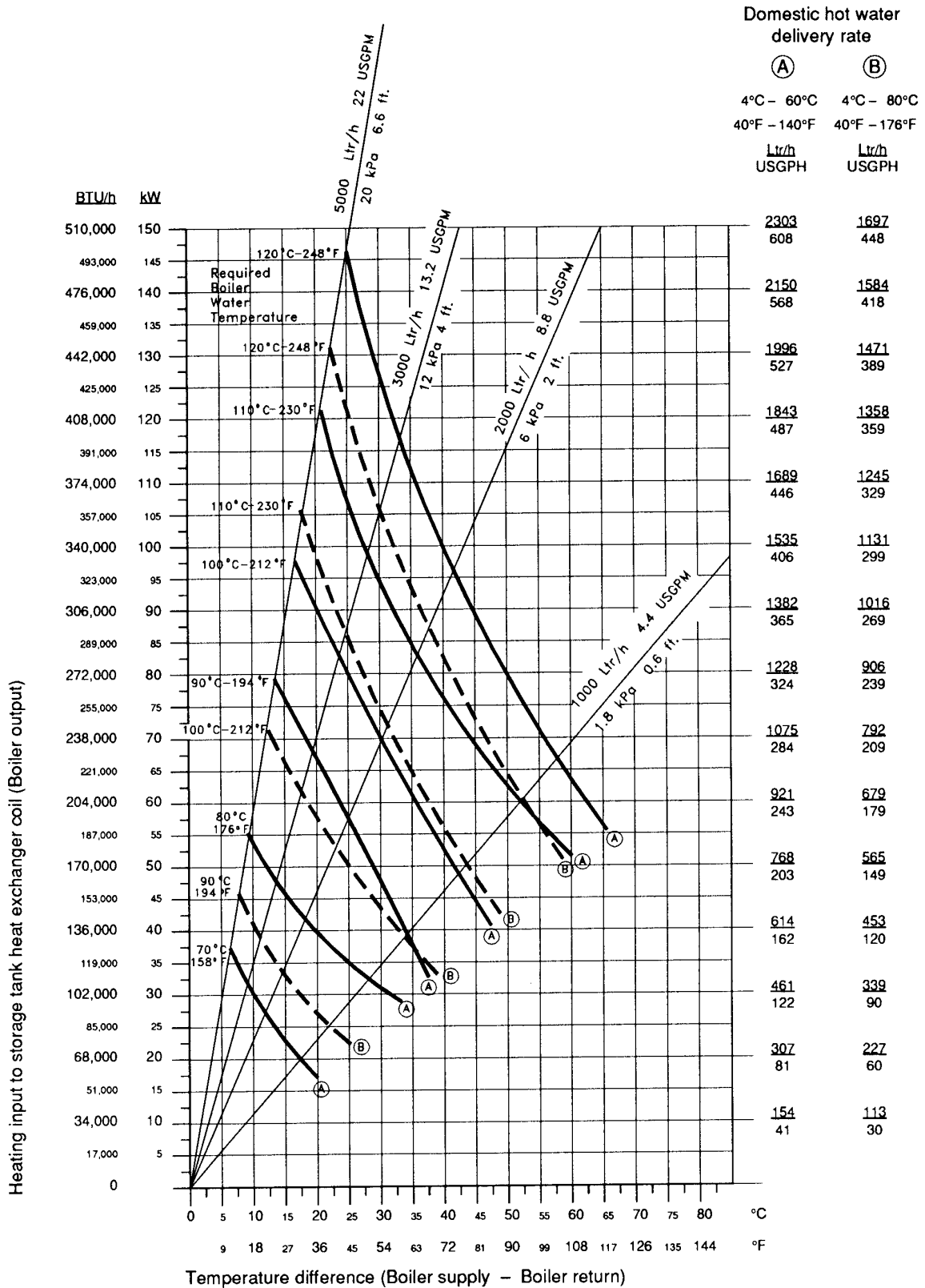

Continuous Flow Capacity Chart *(continued)*

Example: Vitocell 300-H, 119 USG (450 L) capacity

Assume boiler output to tank is 238 MBH. Enter chart at left and draw horizontal line across to recovery rate of 284 GPH or 4.7 GPM for 140°F (60°C) domestic hot water under column A. Where the horizontal line intersects the 194°F (90°C) curve is the point of intersection for the diagonal line used to size the pump. The diagonal line begins at the origin and goes through the point of intersection extending up to the top of the chart. Read between the reference diagonal lines to get a pump specification of 15 GPM at 4.5 ft.

To summarize:

For a Vitocell-H 300 with 119 USG (450 L) capacity and 238 MBH input, the boiler water temperature is 194°F (90°C), difference between boiler return and supply water temperature is 31°F (17°C), recovery rate is 4.7 GPM of 140°F (60°C) DHW, and the pump required is 15 GPM, 4.5 ft. plus pressure drop in piping and boiler. If a multiple tank application is required, i.e. 4 tanks at 238 MBH input each, then the pump selection would be (4 x 15 GPM) 60 GPM at 4.5 ft. plus piping pressure drop.

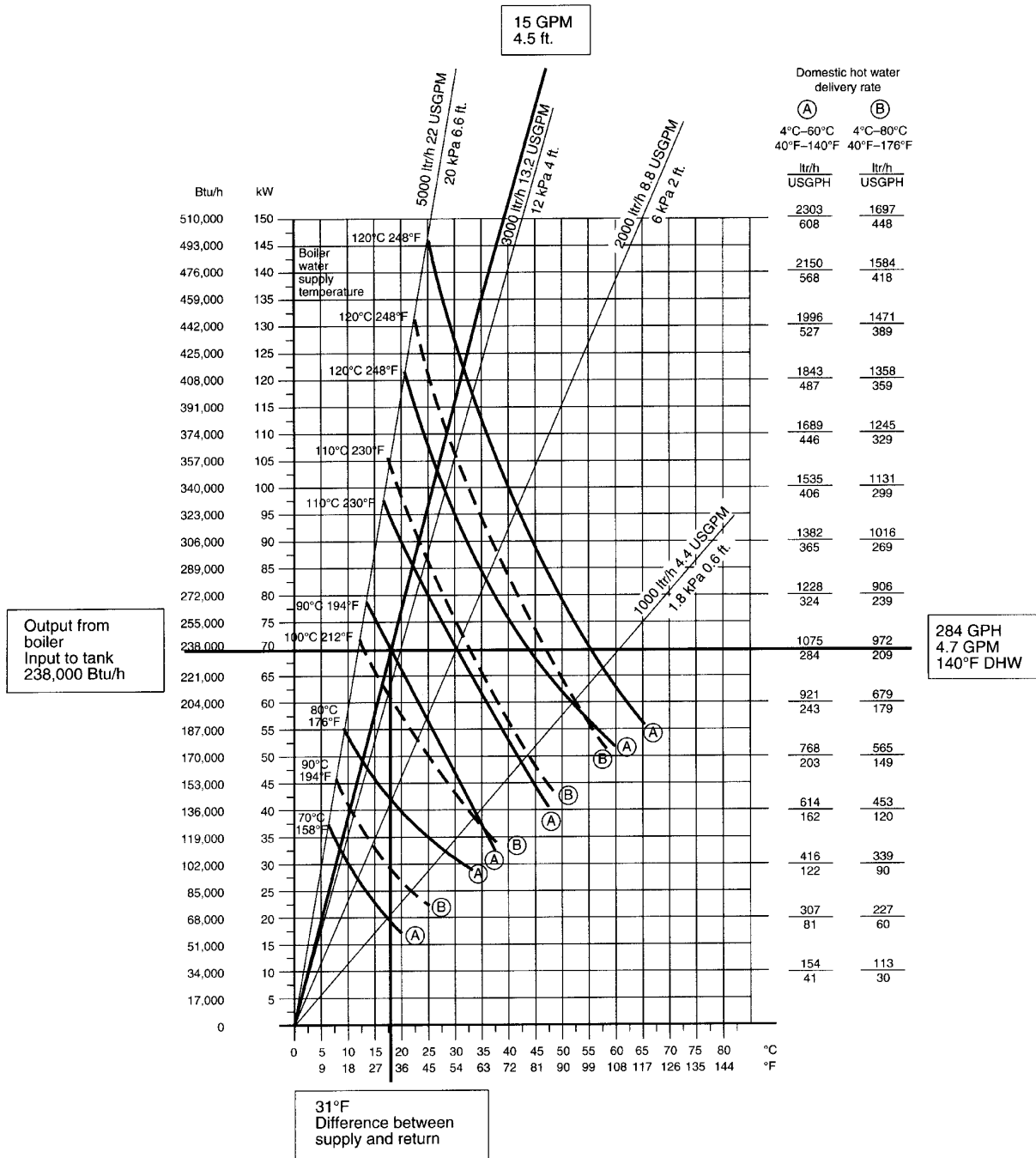

Steam Chart

Continuous flow of domestic hot water at a temperature of 140°F (60°C) at 100°F (56°C) rise with a steam velocity of 164 ft./sec (50 m/sec) using saturated steam.

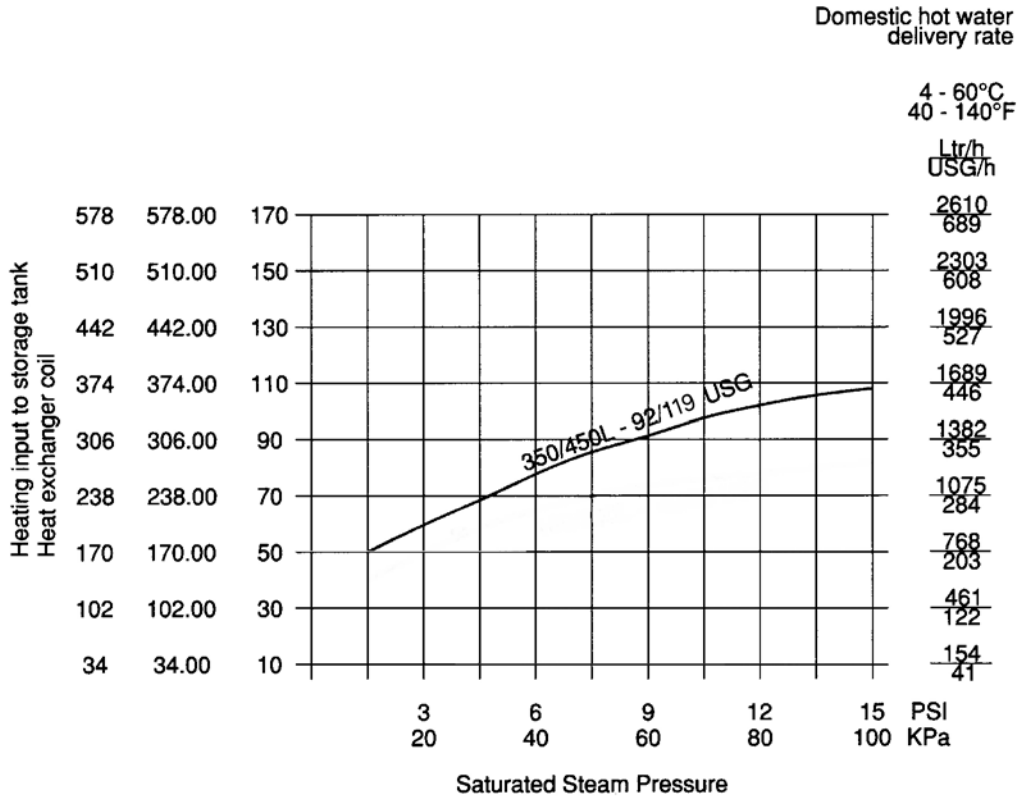

Printed on environmentally friendly (recycled and recyclable) paper.

Technical information subject to change without notice.