

More Features

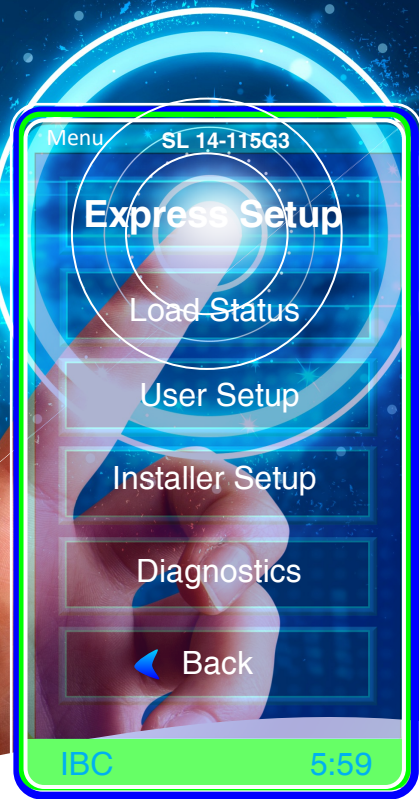

SL 14-115G3

14,000 to 115,000 BTU/H

Residential Condensing Boiler

With Supply and Return connections on both sides of the boiler your installation can't get any easier. Use the left side, the right side or both... the choice is yours.

- **New Touch Screen V-10 Boiler Control**
Express set up, Remote monitoring & diagnostics, Easy USB programmability, Optional true native BACnet, Intuitive alert system.
- 95% A.F.U.E.
- PVC/CPVC/PP approved - venting up to 480 ft.
- Built-in CSA/UL approved LWCO and manual reset high limit.
- 8:1 turndown ratio means you have the power to heat your home in the coldest weather yet reduce short cycling when the weather is mild.
- Built-in multiple zone pump control - up to 4 zones replacing the need for external pump controls.
- Built-in outdoor reset control of water temperature.
- **MFZ** Technology: Patented moisture management system. Protects and ensures long life for all components in the boiler.
- The most advanced stainless steel fire tube boiler on the market today.
- Increased efficiency: Custom baffling to ensure even



heat transfer and long life.

- Reverse flow detection.
- Very low water side and combustion side pressure drops.
- Connect your IBC Indirect Water Tank directly to the boiler without a primary loop.
- Unmatched safety features.
- Easier to install and service.
- Limited lifetime residential heat exchanger warranty.



V-10 PORTAL

A secure method of remotely managing your SL Boiler from any location.

Boiler control on the go!

IBC Better Boilers

IBC Better Boilers

SL 14-115G3 Condensing Boiler

Specifications	SL 14-115G3
CSA Input (Natural Gas or Propane *) - MBH	14 - 115
CSA Input (Natural Gas or Propane *) - KW	4.1 - 34
CSA Output - MBH	13.3 - 109
CSA Output - KW	5.5 - 32
A.F.U.E.	95%
Min gas pressure (NG or Propane) - inch w.c.	4
Max gas pressure (NG or Propane) - inch w.c.	14
Ambient temperature - Low (°F/°C)	32°F / 0°C
Ambient temperature - High (°F/°C)	122°F / 50°C
Max relative humidity (non-condensing)	90%
Min water temperature	34°F / 1°C
Max water temperature (electronic hi-limit)	190°F / 87.8°C
Max water temperature (mechanical hi-limit)	200°F / 93.3°C
Max ΔT - supply / return (electronic fence)	40°F
Power use (120Vac/60Hz) - Watts @ full fire - Watts	54 (less pumps)
Weight (empty) - lbs/Kg	85 / 39
Pressure vessel water content - USG/Liters	2.9 / 11
Max boiler flow rate - USgpm	14
Min boiler flow rate - USgpm	2
Max operating pressure - psig	30
Min water pressure - psig	8
Approved installation altitude - ASL	0 - 12,000'
Maximum equivalent vent length, each side (Natural Gas or Propane)	2" 100' 3" 240'
Air intake options: either direct vent or indoor supply	

Fuel Conversion Kit included.
Boilers are shipped with 30psi pressure relief valve.

Description	SL 14-115G3
A Exhaust outlet	3" Schedule 40
B Combustion air	3" Schedule 40
C LCD Display	2 1/4" x 4"
D Water outlet	1" NPT - M
E Water inlet	1" NPT - M
F Knock-outs (8)	1/2"
G Gas inlet	1/2" NPT - F
H Condensate outlet	3/4" Hose

Exhaust pipe size	Maximum equivalent length
Sched.40; Rigid PPs	
2"	100'
3"	240'
90° Vent elbow	allow 8' equivalent
90° Long sweep elbow	allow 5' equivalent
45° Elbow	allow 3' equivalent
PPs 87-90° Elbows	use 8' equivalent
2" SS Sidewall Terminal (SST)	allow 20' equivalent of 2" shed. 40
3" SS Sidewall Terminal (SST)	allow 20' equivalent of 3" shed. 40
Flexible PPs	
3" Flexible	45' (max.) lineal x 1.2 = equivalent

Surface	Distance from combustible surfaces	Recommended distance for installation and service
Front	2"	24"
Rear	0"	0"
Left side	1"	4" (to non-combustibles)
Right side	1"	4" (for electric and gas if required)
Top	2"	6" (for vent connection)
Bottom	0"	12" (for condensate trap and piping)

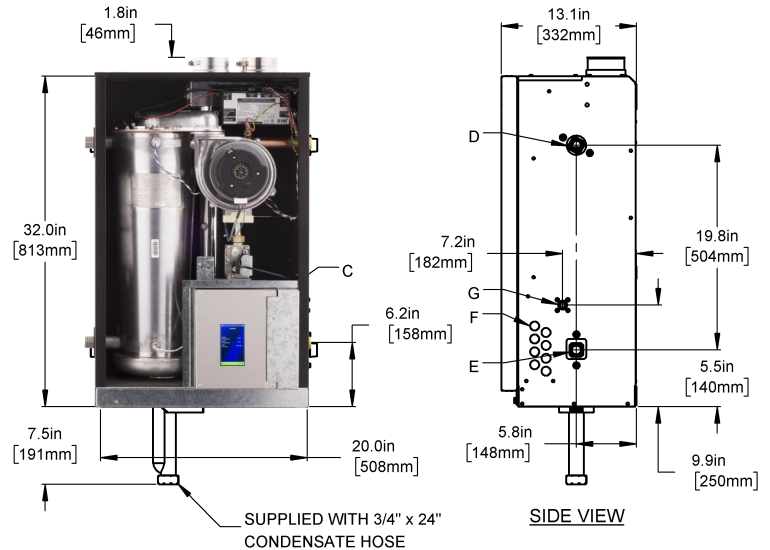

FRONT VIEW

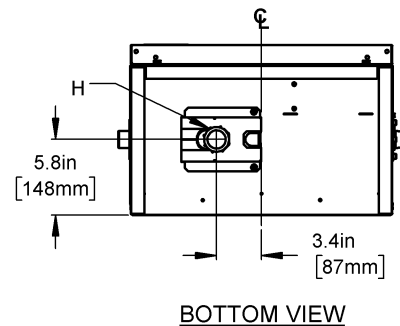
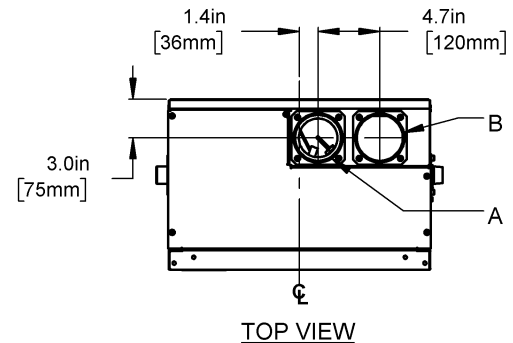

Boiler Head Loss							
Flow rate (gpm)	2	4	6	8	10	12	14
Head loss @ flow (ft wc)	0.5'	1.5'	2.5'	3.0'	4.0'	4.5'	6.0'

Pressure vessel head loss



As part of our continuous product improvement, IBC reserves the right to change specifications and design without notice.

Canada 8015 North Fraser Way, Burnaby, BC V5J 5M8
Unit 5, 1455 16th Ave, Richmond Hill, ON L4B 4W5
USA 4203 Industrial Court, Sheboygan, WI 53083
Unit 1, 1100 Taylors Lane, Cinnaminson, NJ 08077

Tel: 604 877 0277 Fax: 604 877 0295
Tel: 905 918 0113 Fax: 604 877 0295
Tel: 920 783 8340 Fax: 920 783 8339
Tel: 856 877 0544 Fax: 856 735 5584

www.ibcboiler.com
Toll Free: 1 844 HEAT IBC (432 8422)