

L7103 Oil Electronic Water Heater Aquastat[®] Controllers

INSTALLATION INSTRUCTIONS

APPLICATION

The L7103 Oil Electronic Water Heater Aquastat[®] Controller provides electronic temperature sensing in a UL limit-rated control with a single sensing probe. The L7103 controls oil burner and tank temperature.

The L7103 series of controls provide status and diagnostic information through a 7-segment LED display.

SPECIFICATIONS

Electrical Ratings:

Voltage: 120 Vac, 60 Hz.

Power: 7 VA maximum at 120 Vac plus external loads.

Burner Relay:

7.4A at 120 Vac Full Load Amperage (FLA);

44.4A inrush Locked Rotor Amperage (LRA);

Less Ignition Load: 360 VA.

NOTE: All loads combined cannot exceed 2000VA.

Environmental Ratings:

Temperature: -30°F to +150°F (-34°C to +66°C).

Humidity: 0 to 95% relative humidity, noncondensing.

Approvals:

Underwriters Laboratories Inc. Component Recognized.

Canadian Underwriters Laboratories Inc. Component Recognized.

Accessories (order separately)

14,000,485-016 1/4 in. diameter, 1-1/4in long glass cartridge Fuse, 1A, Slow-Blow

50001464-001 Sensor

120650 Heat Conductive Compound

121371AA Sensor Well Clamp

122555E Well (3/4 NPT, 4 1/2" Insulation)

INSTALLATION

When Installing this Product...

1. Read these instructions carefully. Failure to follow them could damage the product or cause a hazardous condition.
2. Check the ratings given in the instructions and on the product to make sure the product is suitable for your application.
3. The installer must be a trained, experienced service technician.
4. After installation is complete, check out product operation as provided in these instructions.
5. Set High Limit to the settings recommended by the appliance OEM.
6. Record the maximum high limit setting from the replaced control in the text box provided on the cover insert label.
7. Record the high limit setting set at time of installation in the text box provided on the cover insert label.



WARNING

Electrical Shock Hazard.

Can cause severe injury, death or property damage.

Disconnect power supply before beginning installation to prevent electrical shock or equipment damage.

Mounting

The L7103 model is available in a well-mount, horizontal or vertical position, or flush mount remote from the well assembly. Dimensions for the variety of mounting options are shown in Fig. 1. Note that each identity will have only a single mounting option.



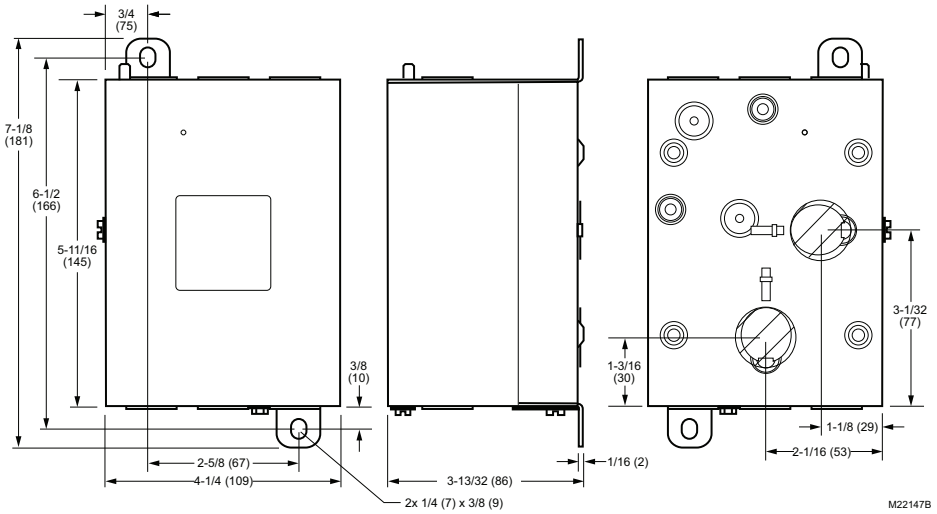

Fig. 1. L7103 mounting dimensions in in. (mm).

IMPORTANT

Immersion well must fit sensing element and sensor must rest against bottom of well.

New Installation

Order well assemblies separately; see Accessories and form 68-0040, Immersion Wells and Compression Fittings for Temperature Controllers. Install the well so water of average temperature can circulate freely over the well.

1. Turn off all power and drain.
2. Sparingly coat the well threads with pipe dope.

NOTE: Do not attempt to tighten by using the case as a handle.

3. Install the well in the tapping and tighten securely.
4. Refill and check for water leakage.
5. Loosen but do not remove the well clamp screw.
6. Fit the case into the well so the clamp on the case slides over the flange on the well.
7. Securely tighten the clamp screw.
8. Insert the sensor element into the well until it bottoms. See Replacement Sensor Installation section for details. (If necessary, slightly bend the wire inside the case to hold the sensor against the bottom of the well.)
9. Turn power ON.
10. Set High Limit setpoint to the settings recommended by the OEM. (See Operation.) (See Installation steps 5 and 6.)

IMPORTANT

Best thermal response is obtained with a well that snugly fits the sensor. Insert the sensor until it rests against the bottom of the well. Use a well of correct length and bend the wiring, if necessary, to hold the bulb against the bottom of the well.

If the well is not a snug fit on the sensor, use heat-conductive compound (see Accessories) as follows: Fold the plastic bag of compound lengthwise and twist it gently. Then snip off end of bag and work the open end of the bag all the way into the well. Slowly pull out the bag while squeezing it firmly to distribute compound evenly in the well. Bend the wiring, if necessary, to hold the sensor against the bottom of the well and to hold outer end of the sensor in firm contact with the side of the well. See Fig. 2. Wipe excess compound from the outer end of the well.

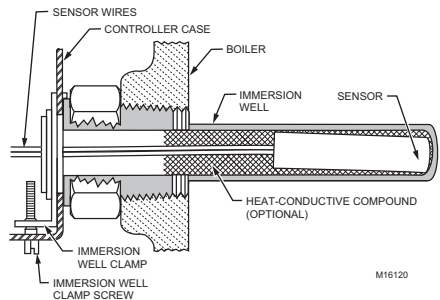

Fig. 2. Position of sensor in immersion well.

Well-Mounted Aquastat® Replacement

Turn off all power and remove the old control. Refer to the cover insert of the old control to identify and tag each external lead as it is disconnected. If the old well is unsuitable for the new installation, remove it and proceed with instructions for new installation. If the old well is suitable, use it.

1. Loosen but do not remove the well clamp screw on the side of the control case.
2. Position immersion well clamp snugly over the flange of the adapter and tighten the clamp screw.
3. Insert the sensor into the well as shown in Fig. 2. (See Replacement Sensor Installation section for details.)

Replacement Sensor Installation

Turn off all power and:

1. Carefully disconnect sensor from circuit board by pulling gently on the connector.
2. Gently pull sensor from thermo well and through circuit board by pulling on leadwires.
3. Carefully align replacement sensor with hole in circuit board and guide through Aquastat® case and into well. See Fig. 5.
4. Make sure sensor is fully seated to bottom of well. See Fig. 3. Use a small pencil to measure depth of sensor in well, if necessary.
5. Connect sensor to circuit board by pressing connector on sensor unit into mating connector on circuit board (Fig. 3).

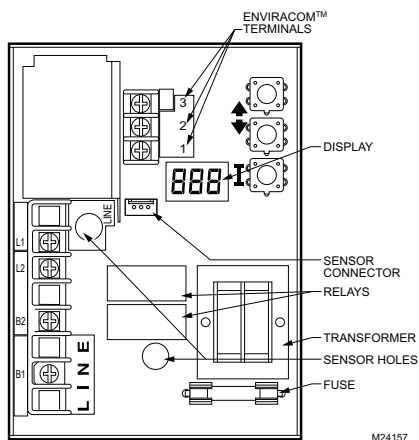

Fig. 3. Circuit board, showing sensor connection and well holes for vertical mount models.

WIRING

⚠ WARNING

Electrical Shock Hazard.

Can cause serious injury or death.

Disconnect power supply before making wiring connections to prevent electrical shock or equipment damage.

All wiring must comply with local electrical codes and ordinances. Do not exceed the specifications in the Application section when wiring this control. Use wire rated for 90°C or higher.

IMPORTANT

The terminals on these Aquastat® Controllers are approved for use with copper wire only.

Follow the appropriate wiring diagrams shown on the inside of the front cover of the L7103.

OPERATION

General

The L7103 Oil Electronic Water Heater Aquastat® Controller is a primary safety limit-rated device designed for use with oil fired line voltage burners. Many systems do not include wiring or control compartments as part of the design, but are provided with an integral, replaceable, immersion well that is the mounting hardware for the Aquastat® Controllers. Wiring to the other controls is done through flexible metal conduit.

For systems that do include a remotely (flush) mounted control, the wiring may be completed with conduit or routed behind the sheet metal.

A separate electromechanical high-limit is not required in a system that uses this control to meet Underwriters Laboratories Inc. requirements for UL 726 and UL 353.

The L7103 setpoint is adjustable, see Adjusting Settings.

The overall range of the setpoint varies by OS model.

Adjusting Settings

To discourage unauthorized changing of Aquastat® settings, a procedure to enter the adjustment mode is required. To enter the adjustment mode, press the **UP**, **DOWN**, and **I** buttons (see Fig. 5) simultaneously for three seconds. Press the **I** button until the feature requiring adjustment is displayed:

- SET — Set-Point
- °F — °C.

Then press the **UP** and/or **DOWN** buttons to move the set point to the desired value. After 60 seconds without any button inputs, the control will automatically return to the **READ** mode.

Display

In the **RUN** mode, the Aquastat® will flash "tt" (tank temp) followed by the temperature (i.e., 150), followed by °F or °C.

To read settings, press the **I** key to read the parameter of interest. For example, press **I**, and (LSP) local set-point is displayed, followed by a three-digit number, i.e., 150, followed by °F or °C. See Display Readout, Fig. 5.

After approximately 60 seconds without any key presses, the display will enter a dim display mode. To return to the bright display mode, simply press any key.

Text	Description	Display Shows
tt	Tank Temperature	tt
LSP	Local Setpoint	LSP
brn	Burner Status	brn
err	Error Code	Err
f	Degrees Fahrenheit	OF
c	Degrees Celsius	OC
ESP	Requested EnviraCom Setpoint	ESP

Fig. 4. Display readout definitions.

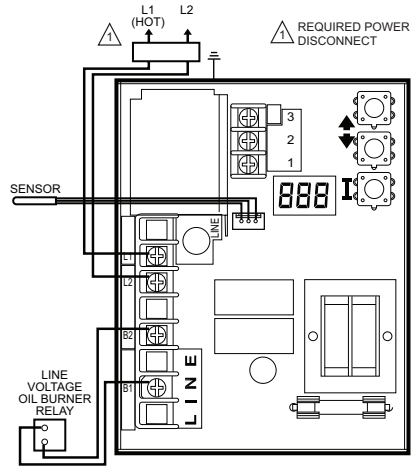

Fig. 5. L7103 connections.

Operation

The L7103 can be in any of three operational states: Normal, High-Limit and Error. The controller moves back and forth from High-Limit to Normal state as part of normal operation. The operating states are:

1. Normal: Tank temperature has gone below the setpoint (minus the differential). The burner is energized and the water temperature and has not exceeded the setpoint.
2. High-Limit: Tank temperature has gone above the setpoint and has not dropped below the setpoint (minus the differential).
3. Error: The controller has detected an error condition (e.g., open sensor) and has shut down the burner output. The controller continues to monitor the system and automatically restarts if the error condition clears. See Table 2.

The operating sequence is shown in Table 1.

High Limit Controller

The high limit opens and turns off the burner when the water temperature reaches the setpoint. The high limit automatically resets after the water temperature drops past the setpoint and through the differential.

CHECKOUT

Put the system into operation and observe operation through at least one complete cycle to make sure that the controller operates properly. See Troubleshooting section to use LED to assist in determining system operation.

TROUBLESHOOTING

When attempting to diagnose system performance, reference to the LED display can help to identify specific areas not working properly. The LED display will scroll "err", followed by a digit (1-8). See Table 2 for a description of each error and suggested actions. If enabled, Error 8 is manually reset by holding down all three user keys for 15 seconds.

Automation and Control Solutions

Honeywell International Inc.
1985 Douglas Drive North
Golden Valley, MN 55422
customer.honeywell.com

Honeywell Limited-Honeywell Limitée
35 Dynamic Drive
Scarborough, Ontario M1V 4Z9

® U.S. Registered Trademark
© 2005 Honeywell International Inc.
69-1845—01 M.S. 11-05

Printed in U.S.A. on recycled paper containing at least 10% post-consumer paper fibers.

Table 1. L7103 Controller Operating Sequence.

Action	System Response
Normal Condition	Water temperature has dropped below the set-point minus the differential and has not exceeded the high limit setting.
High Limit Condition	Water temperature has risen above the set-point and has not dropped below the set-point minus the differential.
Error condition.	If an error condition is detected, all outputs are shut down. Burner is off. Control continues to function and restarts when error is corrected. During the error check sequence, the system checks for drift in the sensor and corrosion in the connections.

Table 2. LED Error Codes.

Error Code	Cause/Action
Err1	Sensor fault; check sensor.
Err2	ECOM fault; check EnviraCOM™ wiring.
Err3	Hardware fault; replace control.
Err4	B1 fault; check B1 wiring/voltage.
Err5	Low Line; Check L1-L2, 110 Vac.
Err6	Fuse; Check ECOM wires, Replace fuse.
Err7	EEPROM, HL, LL, Hdf, Ldf; Reset to default values. Restore desired settings.
Err8	ECO Error. Temperature has reached ECO setting. Error will be reset either manually or automatically (at specific temperature) depending on OS Model.

