

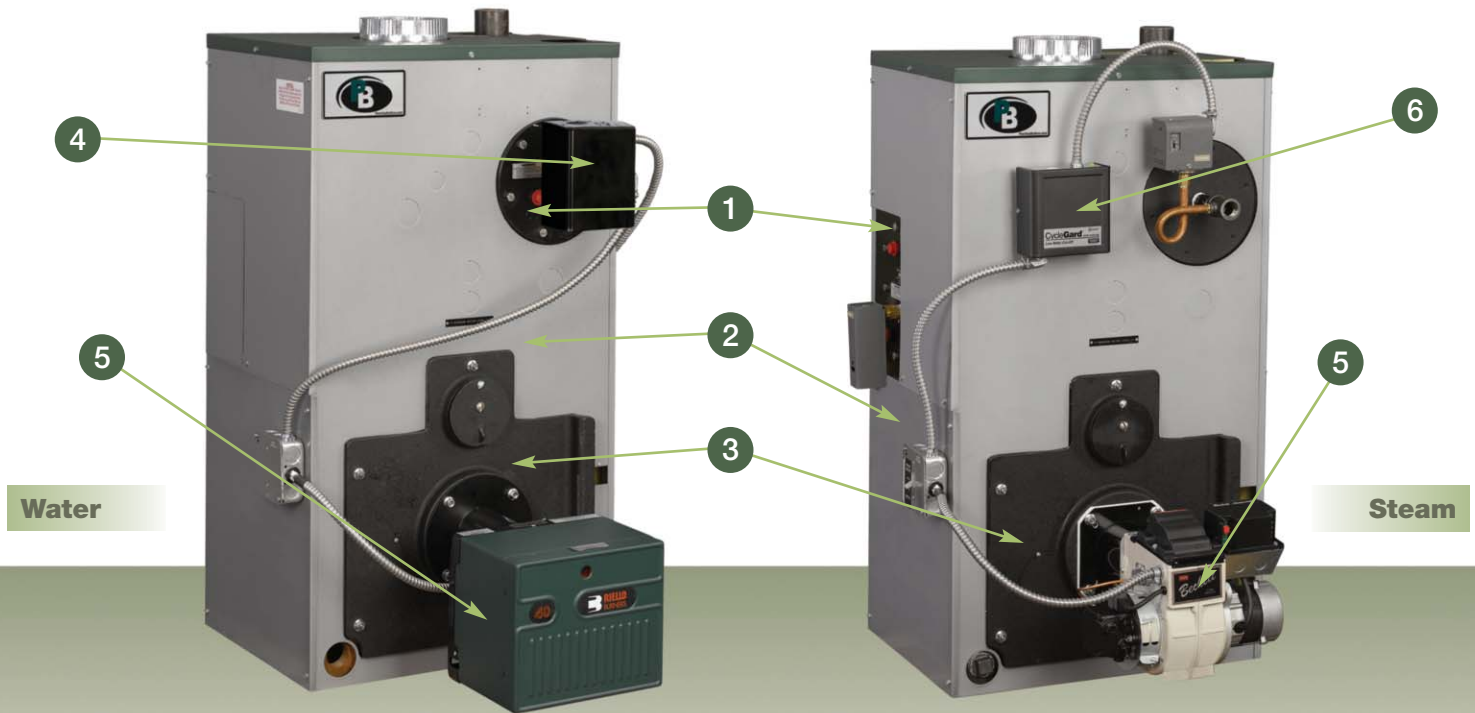

Series EC/ECT™

Residential Oil Boilers



1 Tankless Heater (Optional)

2 Insulated Jacket

3 Full Plate Swing-Out Door

4 Boiler Limit and Reset Control with Circulator Relay and LWCO

5 Flame Retention Burner

6 Low Water Cutoff

Series EC/ECT™ Boiler Features

- Up to 86.6% AFUE
- Residential, Oil-fired Boiler for Hot Water or Steam Systems
- Natural Draft (Chimney) Venting
- High Efficiency, Flame Retention Burners—choice of Beckett, Carlin or Riello
- 11 sizes Available (3-6 sections); Packaged or Knockdown Boilers
- Cast Iron Sections—Factory Tested and Assembled with Steel Push Nipples
- Large Water Content, Wet Base Section Design—Ideal for Steam and Large Volume Hot Water Applications
- Deluxe Powder Coated Steel Jacket—Reduces Boiler Heat Loss
- Full Plate Swing Out Door—For Quick and Easy Cleaning
- Optional Tankless Coils for Domestic Hot Water (Hot Water Boilers)

Standard Equipment

- > Taco Circulator (Water Boilers)
- > Barometric Draft Damper
- > Drain Valve
- > Service Switch on Packaged Boilers
- > Probe Type LWCO (Packaged Steam Boilers)
- > Skim Tapping (Steam Boilers)
- > Boiler Reset Control with Low Water Cut-off for Increased Efficiency and Safety (Water Boilers)

All residential cast iron boilers include a full one-year warranty. A limited, lifetime warranty is provided for the cast iron sections of Peerless® residential hot water boilers. A limited, ten-year warranty is provided on the cast iron sections of residential steam boilers. Visit PeerlessBoilers.com for complete details.



Technical Information

Tapping Locations

Location	Size N.P.T	Steam	Water
E	3/4"	Low Limit Control	N/A
F	3/4"	Pressure Gage	Limit Control
G	1/4"	N/A	Temperature-Pressure Gage
H	1/2"	Gage Glass and Float LWCO	N/A
J	2"	Return	Alternate Return
K	3/4"	Secondary Probe LWCO	N/A
L	3/4"	Safety Valve	Safety Relief Valve
M	1-1/4"	N/A	Return
N	3/4"	Drain Valve	Drain Valve
O	1-1/2"	Skim Tappig	Optional High Limit
P	3/4"	Primary Probe LWCO	N/A
R	1/2"	Gauge Glass for Primary Probe LWCO	N/A

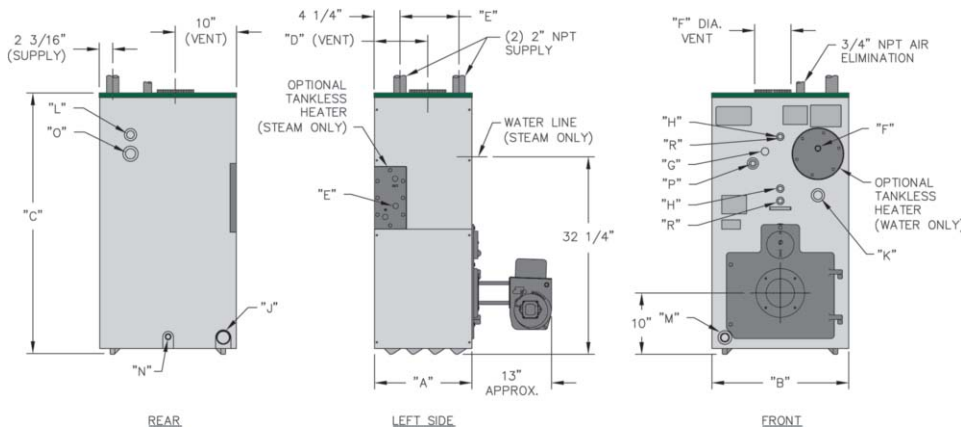

Boiler Dimensions

Boiler Model Number	Jacket Depth "A"	Jacket Width "B"	Jacket Height "C"	Rear of Jacket to C/L of Vent "D"	Distance Between Supply Tappings "E"	Vent Size "F" Dia.
EC/ECT-03	15-3/4"			8-3/4"	9-1/16"	6"
EC/ECT-04	19-15/16"	22-1/2"	42"	10-7/8"	13-1/4"	7"
EC/ECT-05	24-1/8"			13"	17-7/16"	8"
EC/ECT-06	28-5/16"			15-1/16"	21-5/8"	9"

Crated Dimensions & Shipping Weights

Boiler Model Number	Length WPC-WPCT	Width WPC-WPCT	Height WPC-WPCT	Approximate Shipping Weight (lbs.)					
				Knockdown		Package			
				W-S	WU-SU	WPC	WPCT	SP	SPT
EC/ECT-03	40"	28"	47"	570	610	700	710	690	700
EC/ECT-04	40"	28"	47"	710	760	840	850	830	840
EC/ECT-05	48"	28"	47"	840	880	—	—	—	—
EC/ECT-06	48"	28"	47"	990	1030	—	—	—	—

Boiler Ratings

Series EC/ECT™												Water Content, Gallons		Minimum Stack Draft Required, in. W.C.
Boiler Model Number	Input		Output ⁵ , MBH		Net Ratings ⁴			AFUE, %		Thermal Efficiency ⁶ , %	Combustion Efficiency ⁶ , %	Water	Steam	
	GPH ¹	MBH	Water	Steam	Steam, sqft	Steam, MBH ³	Water, MBH ²	Water	Steam					
	EC/ECT-03	0.75	105	92	91	283	68	80	86.6	85.4	—	—	17.40	14.16
EC/ECT-03	1.00	140	121	120	375	90	105	85.3	84.4	—	—	17.40	14.16	-04
EC/ECT-03	1.20	168	143	142	446	107	124	84.0	82.9	—	—	17.40	14.16	-05
EC/ECT-04	1.25	175	152	151	471	113	132	86.1	85.1	—	—	21.72	17.28	-03
EC/ECT-04	1.50	210	181	180	563	135	157	85.2	84.5	—	—	21.72	17.28	-04
EC/ECT-04	1.75	245	209	208	650	156	182	84.5	83.8	—	—	21.72	17.28	-05
EC/ECT-05	1.75	245	214	212	663	159	186	86.2	85.6	—	—	26.04	20.40	-03
EC/ECT-05	2.00	280	241	240	750	180	210	85.2	84.6	—	—	26.04	20.40	-04
EC/ECT-05 ⁺	2.40	336	279	279	872	209	243	—	—	83.0	85.1	26.04	20.40	-05
EC/ECT-06 ⁺	2.75	385	321	321	1004	241	279	—	—	83.3	84.4	30.36	23.52	-04
EC/ECT-06 ⁺	3.00	420	347	347	1083	261	302	—	—	82.5	83.7	30.36	23.52	-05

1 Burner input based on No. 2 fuel oil with a heating value of 140,000 Btu per gallon.

2 Net water ratings based on an allowance of 1.15.

3 Net steam ratings based on an allowance of 1.333.

4 Consult factory before selecting a boiler for installations having unusual piping and pickup requirements, such as intermittent system operation, extensive piping systems, etc.

5 Output is Heating Capacity for models with inputs <300 MBH and Gross Output for models with inputs >300 MBH. Heating Capacity and Annual Fuel Utilization Efficiency (AFUE) ratings are based on U.S. Government tests, with 13% CO₂ and -0.02 w.c. draft over fire.

6 Combustion efficiency, thermal efficiency and gross output are determined in accordance with BTS 2000 Testing Standard; @ 12.5% CO₂ and -0.02 w.c. draft over fire.



PeerlessBoilers.com



Printed on Recycled Paper

PeerlessBoilers.com

CUT-EC R5 (01/16-4M)

Printed in U.S.A.

©2016 PB Heat, LLC. All rights reserved.