

Installation Instructions

for use by heating contractor

VIESSMANN®

Vitodens 200-W, B2HA

Models 80 to 100, 285 to 352

Wall-mounted, gas-fired condensing boiler

For operation with natural gas and liquid propane gas

Heating input: 71 to 352 MBH

20 to 103 kW



VITODENS® 200-W



Product may not be exactly as shown

IMPORTANT

Read and save these instructions for future reference.

Safety, Installation and Warranty Requirements

Please ensure that these instructions are read and understood before commencing installation. Failure to comply with the instructions listed below and details printed in this manual can cause product/property damage, severe personal injury, and/or loss of life. Ensure all requirements below are understood and fulfilled (including detailed information found in manual subsections).

■ **Product documentation**

Read all applicable documentation before commencing installation. Store documentation near boiler in a readily accessible location for reference in the future by service personnel.

► *For a listing of applicable literature, please see section entitled "Important Regulatory and Safety Requirements".*



■ **Warranty**

Information contained in this and related product documentation must be read and followed. Failure to do so renders the warranty null and void.



■ **Licensed professional heating contractor**

The installation, adjustment, service and maintenance of this equipment must be performed by a licensed professional heating contractor.

► *Please see section entitled "Important Regulatory and Installation Requirements".*



■ **Contaminated air**

Air contaminated by chemicals can cause by-products in the combustion process, which are poisonous to inhabitants and destructive to Viessmann equipment.

► *For a listing of chemicals which cannot be stored in or near the boiler room, please see subsection entitled "Mechanical room" in the "Installation Instructions".*



■ **Advice to owner**

Once the installation work is complete, the heating contractor must familiarize the system operator/ultimate owner with all equipment, as well as safety precautions/requirements, shutdown procedure, and the need for professional service annually before the heating season begins.

! WARNING

Installers must follow local regulations with respect to installation of carbon monoxide detectors. Follow the Viessmann maintenance schedule of the boiler contained in this manual.

Operating and Service Documentation

It is recommended that all product documentation such as parts lists, operating and service instructions be handed over to the system user for storage. Documentation is to be stored near boiler in a readily accessible location for reference by service personnel.

■ **Carbon monoxide**

Improper installation, adjustment, service and/or maintenance can cause flue products to flow into living space. Flue products contain poisonous carbon monoxide gas.

► *For information pertaining to the proper installation, adjustment, service and maintenance of this equipment to avoid formation of carbon monoxide, please see subsection entitled "Mechanical room" and "Venting requirements" in the "Installation Instructions".*



■ **Fresh air**

This equipment requires fresh air for safe operation and must be installed ensuring provisions for adequate combustion and ventilation air exist.

► *For information pertaining to the fresh air requirements of this product, please see subsection entitled "Mechanical room" in the "Installation Instructions".*

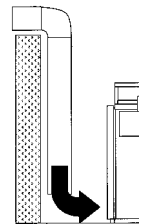

■ **Equipment venting**

Never operate boiler without an installed venting system. An improper venting system can cause carbon monoxide poisoning.

► *For information pertaining to venting and chimney requirements, please see section entitled "Venting Connection". All products of combustion must be safely vented to the outdoors.*



! WARNING

This boiler requires fresh air for safe operation and must be installed with provisions for adequate combustion and ventilation air (in accordance with local codes and regulations of authorities having jurisdiction).

Do not operate this boiler in areas with contaminated combustion air. High levels of contaminants such as dust, lint or chemicals can be found at construction sites, home renovations, in garages, workshops, in dry cleaning/laundry facilities, near swimming pools and in manufacturing facilities.

Contaminated combustion air will damage the boiler and may lead to substantial property damage, severe personal injury and/or loss of life. Ensure boiler/burner is inspected and serviced by a qualified heating contractor at least once a year in accordance with the Service Instructions of the boiler.

Safety, Installation and Warranty Requirements

Fiberglass wool and ceramic fiber materials

WARNING

Inhaling of fiberglass wool and/or ceramic fiber materials is a possible cancer hazard. These materials can also cause respiratory, skin and eye irritation.

The state of California has listed the airborne fibers of these materials as a possible cancer hazard through inhalation. When handling these materials, special care must be applied.

Suppliers of ceramic fiber products recommend the following first aid measures:

- Respiratory tract (nose and throat) irritation:
If respiratory tract irritation develops, move the person to a dust free location.
- Eye irritation: If eyes become irritated, flush immediately with large amounts of lukewarm water for at least 15 minutes. Eyelids should be held away from the eyeball to ensure thorough rinsing. Do not rub eyes.
- Skin irritation: If skin becomes irritated, remove soiled clothing. Do not rub or scratch exposed skin. Wash area of contact thoroughly with soap and water. Using a skin cream or lotion after washing may be helpful.
- Gastrointestinal irritation: If gastrointestinal tract irritation develops, move the person to a dust free environment.

Suppliers of fiberglass wool products recommend the following precautions be taken when handling these materials:

- Avoid breathing fiberglass dust and contact with skin and eyes.
- Use NIOSH approved dust/mist respirator.
- Wear long-sleeved, loose fitting clothing, gloves and eye protection.
- Wash work clothes separately from other clothing. Rinse washer thoroughly.
- Operations such as sawing, blowing, tear-out and spraying may generate airborne fiber concentration requiring additional protection.

First aid measures

- If eye contact occurs, flush eyes with water to remove dust. If symptoms persist, seek medical attention.
- If skin contact occurs, wash affected areas gently with soap and warm water after handling.

WARNING

Appliance materials of construction, products of combustion and the fuel contain alumina, silica, heavy metals, carbon monoxide, nitrogen oxides, aldehydes and/or other toxic or harmful substances which can cause serious injury or loss of life and which are known to the State of California to cause cancer, birth defects and other reproductive harm. Always use proper safety clothing, respirators and equipment when servicing or working nearby the appliance.

About these Installation Instructions

 Take note of all symbols and notations intended to draw attention to potential hazards or important product information. These include "WARNING", "CAUTION", and "IMPORTANT". See below.

WARNING

Indicates an imminently hazardous situation which, if not avoided, could result in loss of life, serious injury or substantial product/property damage.

- ▶ Warnings draw your attention to the presence of potential hazards or important product information.

CAUTION

Indicates an imminently hazardous situation which, if not avoided, may result in minor injury or product/property damage.

- ▶ Cautions draw your attention to the presence of potential hazards or important product information.

IMPORTANT

- ▶ Helpful hints for installation, operation or maintenance which pertain to the product.

- ▶ This symbol indicates that additional, pertinent information is to be found.

- ▶ This symbol indicates that other instructions must be referenced.



Safety

Safety, Installation and Warranty Requirements.....2
 Product documentation.....2
 Warranty.....2
 Licensed professional heating contractor.....2
 Contaminated air.....2
 Advice to owner.....2
 Carbon monoxide.....2
 Fresh air.....2
 Equipment venting.....2
About these Installation Instructions.....3

General Information

Important Regulatory and Installation Requirements.....6
 Codes.....6
 Instructing the system user.....6
 Initial start-up.....6
 Working on the equipment.....6
 Technical literature.....6
 For installations on the Commonwealth of
 Massachusetts.....7
 CSD-1 field testing of high limit switches.....7
Applicability.....8
Product Information.....8
 Multi boiler system.....8

Set-up

Mechanical Room.....9
Before Set-up.....10
Minimum Clearances.....10
 Recommended minimum service clearances.....10

Boiler Connections

Preparing the Connections.....11
Wall Mounting.....13
 Fitting the wall mounting bracket.....13
 Installing the wall mounting bracket.....13
 Installation of mounting bracket on
 brick/concrete wall.....13
 Boiler mounting bracket.....14
 Installation on wood studs.....14
 Installation on metal studs.....14
 Frame Mounting.....16
 Models B2HA 80 to 100, 285 to 352
 Frame Mounting.....17
Connections.....18
 Connecting power.....18
 Boiler venting.....18
 Proper piping practice.....18
 Gas shut-off valve connection.....18
 Gas connection and piping.....19
 Gas piping pressure test.....20
 Heating water connections.....20
 DHW storage tank information.....21
 Making the DHW connections.....21
 Accessing the control unit connections.....22
 Routing the connecting cables.....24
 Connecting DHW sensor.....25
 Setting altitude parameters.....25
 Control base.....26
 External accessory connection box.....27
 Condensate connection.....28

Page

Boiler Connections *(continued)*

Safety Connections.....29
 Installing boiler safety devices.....29
 Low water cut-off.....30

Waterside Flow.....30
 Waterside flow (primary circuit).....30

Installation Examples.....32
 General.....32
 Clearances.....32

System Layout 1-10.....33

Alternative DHW Connection.....43

Boiler in Heating/Cooling.....44
 Boiler in heating/cooling application.....44

Boiler with Low Water Cut-off.....45
 Boiler with low water cut-off (remote-mounted field supplied).....45

Venting Connection.....45

Electrical Connections.....46
 Power supply connection of accessories.....46
 Connection of accessories.....46

Overview of Electrical Connections, Models B2HA 80 to 100, 285 to 352.....47

Accessing the X3 Plug.....49

Connecting the Low-loss Header Sensor.....49

Connecting the Outdoor Temperature Sensor.....50

External 0-10 Volt Signal Connection.....51

Connecting a 24VAC Thermostat.....52

Thermostat Connection.....53

Pump Connection.....54

LON Module.....55
 Installing the LON module to the boiler control board.....55
 Connecting the LON module cable.....55

Accessory Kit.....56
 Accessory kit connections for heating circuit with mixing valve.....56

Closing the Control Unit.....56
 Closing the control cover56

Closing the External Accessory Connection Box.....57

Reinstalling the Front Enclosure Panel.....58
 Instructing the system user.....58

Installation Fittings.....59

Technical Data.....60

Lighting and Operating Instructions.....62

Control Connections

Additional Information

Important Regulatory and Installation Requirements

Codes

The installation of this unit shall be in accordance with local codes or, in the absence of local codes, use CAN/CSA-B149.1 or .2 Installation Codes for Gas Burning Appliances for Canada. For U.S. installations use the National Fuel Gas Code ANSI Z223.1. Always use latest editions of codes.

In Canada all electrical wiring is to be done in accordance with the latest edition of CSA C22.1 Part 1 and/or local codes. In the U.S. use the National Electrical Code ANSI/NFPA 70. The heating contractor must also comply with both the Standard for Controls and Safety Devices for Automatically Fired Boilers, ANSI/ASME CSD-1, and the Installation Code for Hydronic Heating Systems, CSA B214-01, where required by the authority having jurisdiction.

Instructing the system user

The installer of the system is responsible to ensure the system operator/ultimate owner is made familiar with the system functioning, its activation, and its shut-down.

Initial start-up

Initial start-up must be performed by a qualified heating contractor. Proper completion of the Maintenance Record by the heating contractor is also required.

Working on the equipment

The installation, adjustment, service, and maintenance of this boiler must be done by a licensed professional heating contractor who is qualified and experienced in the installation, service, and maintenance of hot water boilers. There are no user serviceable parts on the boiler, burners or control.

Ensure main power supply to equipment, the heating system, and all external controls has been deactivated. Close main gas supply valve. Take precautions in all instances to avoid accidental activation of power during service work.

The following topics must be covered:

Proper system operation sequence.

Explain the equipment.

Demonstrate an emergency shut-down, what to do and what not.

Explain that there is no substitute for proper maintenance to help ensure safe operation.

The Maintenance Record is located in the Service Instructions.

Please carefully read this manual prior to attempting start-up, maintenance or service. Any warranty is null and void if these instructions are not followed.

For information regarding other Viessmann System Technology componentry, please reference documentation of the respective product.

We offer frequent installation and service seminars to familiarize our partners with our products. Please inquire.

Technical literature

Literature for the Vitodens boiler:

- Technical Data Manual
- Installation Instructions
- Service Instructions
- Operating Instructions and User's Information Manual
- Instructions of other Viessmann products utilized and installed
- Installation codes mentioned in this manual

The completeness and functionality of field supplied electrical controls and components must be verified by the heating contractor. These include low water cut-offs, flow switches (if used), staging controls, pumps, motorized valves, air vents, thermostats, etc.

Leave all literature at the installation site and advise the system operator/ultimate owner where the literature can be found. Contact Viessmann for additional copies.

This product comes with several safety instruction labels attached.

Do not remove!

Contact Viessmann immediately if replacement labels are required.

Important Regulatory and Installation Requirements *(continued)*

For installations on the Commonwealth of Massachusetts, the following modifications to NFPA-54 chapter 10 apply:

Excerpt from 248 CMR 5-08:

- 2(a) For all side-wall horizontally vented gas fueled equipment installed in every dwelling, building or structure used in whole or in part for residential purposes, including those owned or operated by the Commonwealth and where the sidewall exhaust vent termination is less than (7) feet above finished grade in the area of the venting, including but not limited to decks and porches, the following requirements shall be satisfied:
1. **INSTALLATION OF CARBON MONOXIDE DETECTORS.** At the time of installation of the side-wall horizontal vented gas fueled equipment, the installing plumber or gasfitter shall observe that a hard wired carbon monoxide detector with an alarm and battery back-up is installed on the floor level where the gas equipment is to be installed. In addition, the installing plumber or gasfitter shall observe that a battery operated or hard wired carbon monoxide detector with an alarm is installed on each additional level of the dwelling, building or structure served by the side-wall horizontal vented gas fueled equipment. It shall be the responsibility of the property owner to secure the services of qualified licensed professional for the installation of hard-wired carbon monoxide detectors.
 - a. In the event that the side-wall horizontally vented gas fueled equipment is installed in a crawl space or an attic, the hard-wired carbon monoxide detector with alarm and battery back-up may be installed on the next adjacent floor level.
 - b. In the event that the requirements of this subdivision can not be met at the time of completion of installation, the owner shall have a period of thirty (30) days to comply with the above requirements; provided, however, that during said thirty (30) day period, a battery operated carbon monoxide detector with an alarm shall be installed.
 2. **APPROVED CARBON MONOXIDE DETECTORS.** Each carbon monoxide detector as required in accordance with the above provisions shall comply with NFPA 720 and be ANSI/UL 2034 listed and IAS certified.
 3. **SIGNAGE.** A metal or plastic identification plate shall be permanently mounted to the exterior of the building at a minimum height of eight (8) feet above grade directly in line with the exhaust vent terminal for the horizontally vented gas fueled heating appliance or equipment. The sign shall read, in print size no less than one-half (1/2) inch in size, "GAS VENT DIRECTLY BELOW. KEEP CLEAR OF ALL OBSTRUCTIONS".
 4. **INSPECTION.** The state or local gas inspector of the side-wall horizontally vented gas fueled equipment shall not approve the installation unless, upon inspection, the inspector observes carbon monoxide detectors and signage installed in accordance with the provisions of 248 CMR 5.08(2)(a) 1 through 4.
- (b) **EXEMPTIONS:** The following equipment is exempt from 248 CMR 5.08(2)(a) 1 through 4:
1. The equipment listed in Chapter 10 entitled "Equipment Not Required To Be Vented" in the most current edition of NFPA 54 as adopted by the Board; and
 2. Product Approved side-wall horizontally vented gas fueled equipment installed in a room or structure separate from the dwelling, building or structure used in whole or in part for residential purposes.

CSD-1 Field Testing of High Limit Switches for Vitodens boilers – where required by law.

As per ASME Boiler and Pressure Vessel Code, section IV, subsection HG-613 TEMPERATURE CONTROL requirements, Vitodens 200-W hot water boilers are protected from over-temperature by two temperature-operated controls. These temperature control devices conform to Standards for Limit Controls, and are accepted by CSA, a nationally recognized testing agency. Each boiler is equipped with a manual reset high temperature limit control and a temperature control that will cut off fuel supply when the system water temperature reaches a preset operating temperature. **VISSMANN IS NOT RESPONSIBLE FOR ANY DAMAGES THAT THE FOLLOWING TEST PROCEDURE MAY RESULT IN BY OVERHEATING THE SYSTEM.**

The Vitodens 200 boilers are equipped with flow switches or sensors that when activated enable the burner to operate. The fixed high limit, when tripped, produces a fault that will require manual reset of the boiler control.

Fixed High Limit fault simulation #1:

- Ensure that the boiler and boiler pump are in normal operating condition (pump output 20 is the boiler pump).
 - Remove the cover from the back of the boiler control allowing access to the boiler control plugs.
 - Under the extended menu (in the Operating manual), select 'Test mode' then 'flue gas test ON' and press 'OK'.
 - The boiler/burner will start a firing cycle and will gradually go into high fire mode.
 - Once the burner ignites, disconnect the boiler pump plug 20 from the boiler control board (gently with pliers).
- Note:** For boiler models equipped with flow switches (only boiler sizes 19 to 100), it may be required that flow switches be jumpered during testing.
- Observe the boiler temperature on the control display.
 - The temperature will gradually rise as more heat is put into the boiler heat exchanger. The burner will then shut off.
 - The boiler temperature should continue to rise and once it reaches 210°F (99°C) the manual reset high limit safety switch will trip electronically generating an F2 fault.
 - Should the limit temperature not be reached during the test, repeat the test with the following additional step;
 - two minutes after the burner shuts off, energize the boiler pump for a maximum of 1 second (by plugging in boiler pump plug 20).

Fixed High Limit fault simulation #2:

- Close the boiler valve and jumper across the flow switch.
- Run the boiler at high fire and it will shut down by the coding card (in B2TB models, set coding address 06 to maximum) but should continue to steady increase the boiler temperature until the fixed high limit is tripped.
- Once the fixed high limit is tripped, slowly open the boiler valve to safely cool the boiler down.

Applicability

CAUTION

The boiler serial number must be provided when ordering replacement parts. Some replacement parts are not reverse compatible with previous versions of the Vitodens 200-W B2HA boiler.

IMPORTANT

When ordering replacement parts, provide either the 16-digit boiler serial number (on the bar code label) or the 12-digit ASME/NB serial number, located as shown underneath boiler front enclosure panel. Refer to page 15 for instructions on how to remove front enclosure panel.

NG and LPG

Model No. B2HA 80, 285

Serial No. 7554705

Model No. B2HA 88, 311

Serial No. 7554706

Model No. B2HA 100, 352

Serial No. 7554707

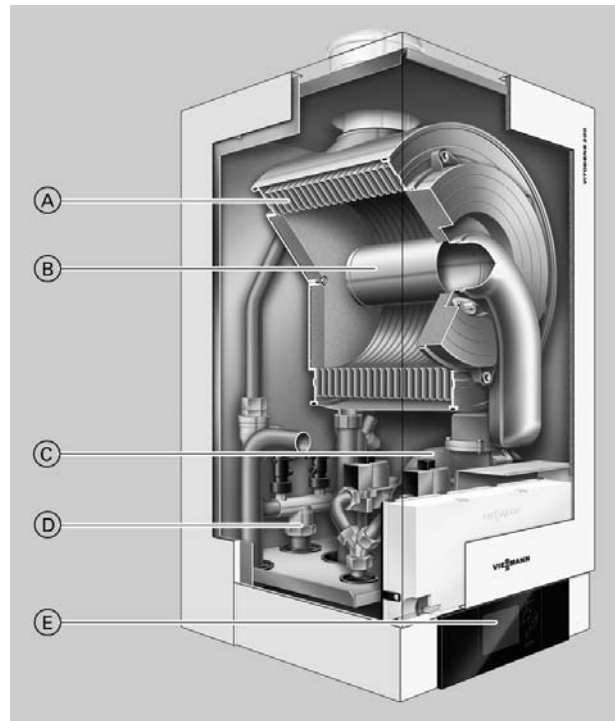

Product may not be exactly as shown

- (A) Inox-Radial heat exchanger made from stainless steel – for high operational reliability and a long service life. Large heating output in the smallest of spaces
- (B) Modulating MatriX DHW tank burner for extremely clean combustion and quiet operation
- (C) Variable speed combustion fan for quiet and economical operation
- (D) Gas and water connections
- (E) Digital boiler control unit

Product Information

Natural gas-fired wall-mounted condensing heating boiler for weather-responsive operation in closed loop, forced circulation hot water heating systems for space heating and domestic hot water (DHW) production.

Models B2HA 80 to 100, 285 to 352 are for operation with natural gas. For a fuel conversion to liquid propane gas refer to the service instructions for details.

Boiler model must be selected based on an accurate heat loss calculation of the building. Ensure boiler model is compatible with connected radiation.

Vitodens 200-W, B2HA boilers are factory-tested and calibrated. Further gas valve adjustments are not typically required during field start-up.

Multi boiler system

In connection with the installation of a multi boiler system observe the installation instructions of the multi boiler system accessories.

Mechanical Room

During the early stages of designing a new home, we recommend that proper consideration be given to constructing a separate mechanical room dedicated to the gas- or oil-fired heating equipment and domestic hot water storage tank(s).

The boiler must be located in a heated indoor area, near a floor drain, and as close as possible to a wall. Whenever possible, install the boiler near an outside wall so that it is easy to duct the venting system to the boiler.

Locate the boiler on a wall capable of supporting 220 lb. (100 kg) [the weight of the boiler filled with water]. Ensure that the boiler location does not interfere with the proper circulation of combustion and ventilation air of other fuel burning equipment within the mechanical room (if applicable).

The maximum room temperature of the mechanical room where the boiler is located must not exceed 104°F (40°C).

Installation area conditions

WARNING

Incorrect ambient conditions can lead to damage to the heating system and put safe operation at risk.

- Ensure ambient temperatures are higher than 32°F (0°C) and lower than 104°F (40°C).
- Prevent the air from becoming contaminated by halogenated hydrocarbons (e.g. as contained in paint solvents or cleaning fluids) and excessive dust (e.g. through grinding or polishing work). Combustion air for the heating process, and ventilation of the boiler room must be free of corrosive contaminants. To that end, any boiler must be installed in an area that has no chemical exposure. The list to the right indicates the main, currently known sources.
- Avoid continuously high levels of humidity (e.g. through frequent drying of laundry).
- Never close existing ventilation openings.

WARNING

If you notice fire coming from the appliance, call the fire department immediately! Do not attempt to extinguish the fire unless qualified to do so.

IMPORTANT

The service life of the boiler's exposed metallic surfaces, such as the casing and fan housing, is directly influenced by proximity to damp and salty marine environments. In such areas, higher concentration levels of chlorides from sea spray, coupled with relative humidity, can lead to degradation of the exposed metallic surfaces mentioned above. Therefore, it is imperative that boilers installed in such environments not be installed using direct vent systems which draw outdoor air for combustion. Such boilers must be installed using room air dependent vent systems; i.e. using room air for combustion. The indoor air will have a much lower relative humidity and, hence, potential corrosion will be minimized.

Sources of combustion and ventilation air contaminants

Areas likely to contain contaminants:

- New building construction
- Swimming pools
- Remodelling areas, hobby rooms
- Garages with workshops
- Furniture refinishing areas
- Dry cleaning/laundry areas and establishments
- Auto body shops
- Refrigeration repair shops
- Metal fabrication plants
- Plastic manufacturing plants
- Photo processing plants
- Beauty salons

Products containing contaminants:

- Chlorine-type bleaches, detergents and cleaning solvents found in household laundry rooms
- Paint and varnish removers
- Hydrochloric acid, muriatic acid
- Chlorine-based swimming pool chemicals
- Spray cans containing chlorofluorocarbons
- Chlorinated waxes and cleaners
- Cements and glues
- Refrigerant leaks
- Calcium chloride used for thawing
- Sodium chloride used for water softening salt
- Permanent wave solutions
- Adhesives used to fasten building products and other similar items
- Antistatic fabric softeners used in clothes dryers

Boiler operation in marine environments (damp, salty coastal areas)

WARNING

Fire causes a risk of burns and explosion!

- Shut down the boiler
- Close fuel shut-off valves
- Use a tested fire extinguisher, class ABC.

Before Set-up

Before placing boiler in its installation location, ensure all necessary accessories are installed.

CAUTION

The boiler must be installed in such a way that gas ignition system components are protected from water (spraying, splashing, etc.) during boiler operation and service.

Minimum Clearances

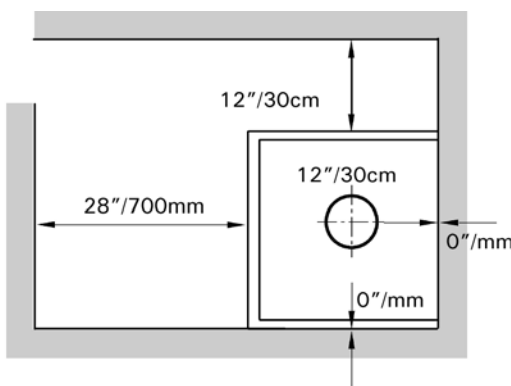

Note: The Vitodens 200-W, B2HA boiler has passed the zero inches vent clearance to combustibles testing requirements dictated by the boiler Harmonized Standard ANSI Z21.13, CSA 4.9 (latest edition) and therefore is listed for zero clearance to combustibles when vented with a single-wall special venting system (AL-29-4C material) or UL/ULC-listed CPVC/PPs gas vent material. The zero inches vent clearance to combustibles for the Vitodens 200-W, B2HA boiler supercedes the clearance to combustibles listing that appears on the special venting system label.

Recommended minimum service clearances

For typical Vitodens installations, Viessmann recommends installing the boiler with the clearances shown in the illustration on the left.

Note: The 12 in. (305 mm) side clearance specified is only recommended to be able to view the boiler certified rating plate, decal and also accommodate the PRV installation kit.

If the pressure relief valve is rotated 90° facing forward by using an extension between the tee and the boiler connection, then this clearance can be reduced to ½ in. This ½ in. clearance is only required to be able to remove the boiler’s front cover and view the rating plate attached to it, if needed.

This reduced clearance is also used in Vitodens multiple boiler installation system as described in the multiple boiler installation instructions.

The Vitodens 200-W, B2HA boiler is approved for closet and alcove installation with the following clearances to combustibles.

Table 1 Clearances

Top	Front	Rear	Left	Right	Vent pipe
0	0 AL CL	0	0	0	0

AL = Alcove
CL = Closet



See the Vitodens 200-W B2HA Venting System Installation Instructions for details.

Preparing the Connections

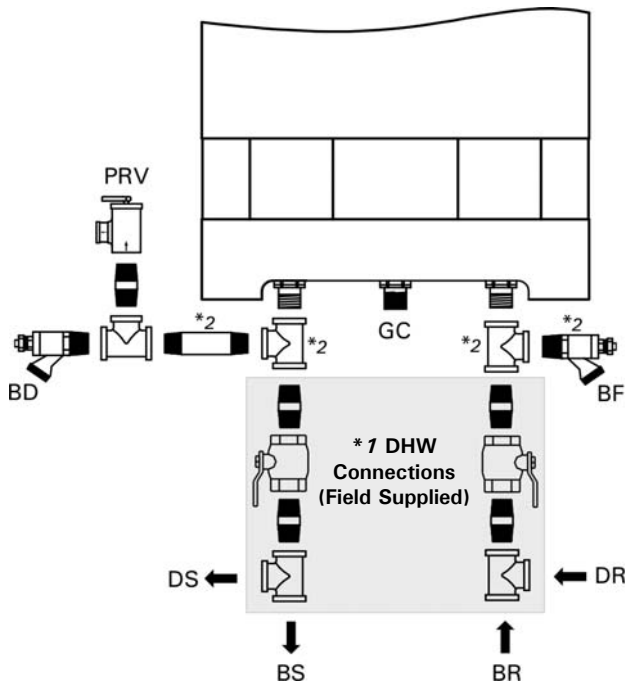

Use an approved pipe sealant or teflon tape when connecting the following installation fittings.

This section constitutes an overview only! Refer to subsequent sections for detailed information on individual piping connections.

Legend

- DR Boiler heating return for domestic hot water production
- DS Boiler heating supply for domestic hot water production
- BD Boiler Drain
- BF Boiler Fill
- BR Boiler Return
- BS Boiler Supply
- GC Gas Connection
- PRV Pressure Relief Valve

*1 See page 43 or alternate DHW connection.

*2 Discard when using the multi-boiler distribution manifold

Preparing the Connections *(continued)*

This section constitutes an overview only! Refer to subsequent sections for detailed information on individual piping connections.

Use an approved pipe sealant or teflon tape when connecting the following installation fittings.

IMPORTANT

The maximum ambient temperature must not exceed 104° F (40° C).

Note: When preparing gas, water and electrical connections in the field, see section entitled "Wall Mounting" on page 13, 14 and 15 of this manual for information regarding the installation of the wall mounting bracket.

1. Heating water connections and gas connection to be made in the field. See illustration and connection-specific section for details.
2. See subsection entitled "Electrical Connections" for details regarding power supply to the Vitodens 200-W B2HA boiler.

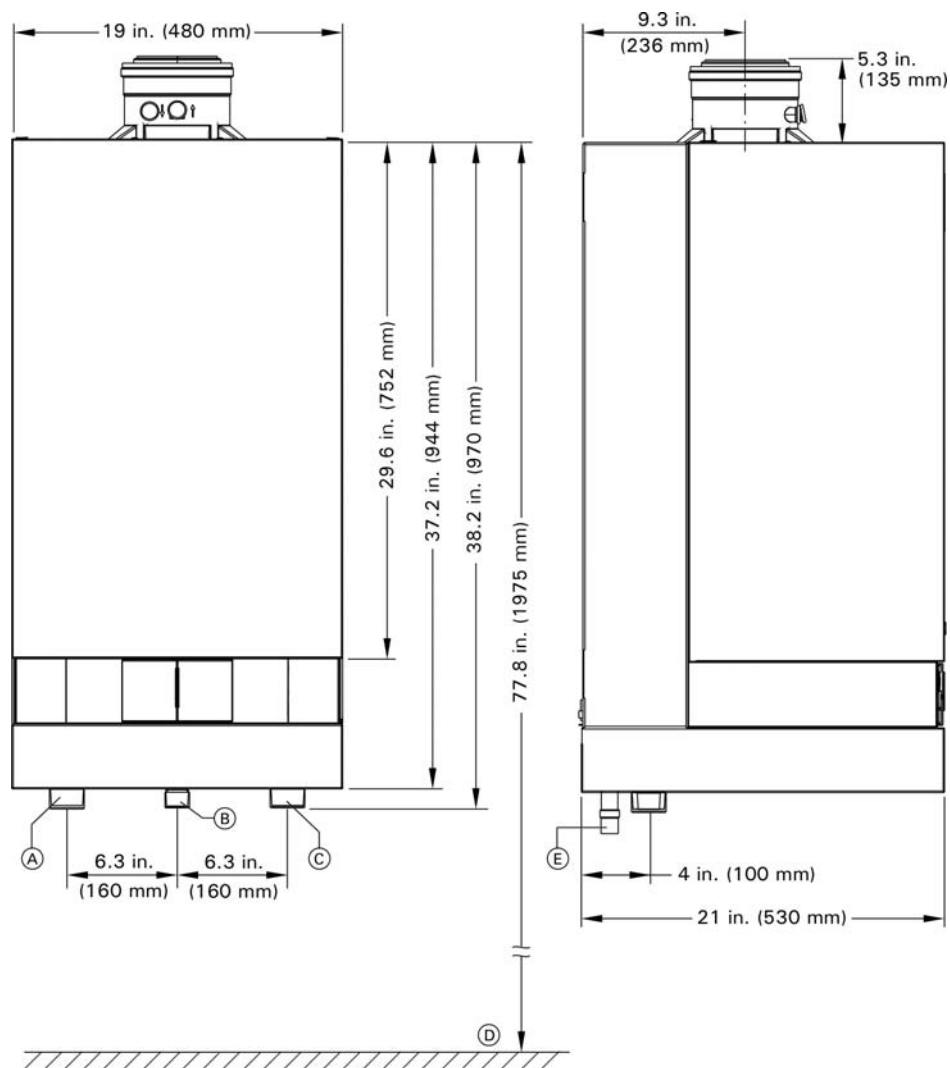

Legend

- Ⓐ Boiler Supply
- Ⓑ Gas Connection, 1 in. NPTF
- Ⓒ Boiler Return
- Ⓓ Recommended height (single boiler system)
- Ⓔ Condensate drain

Wall Mounting

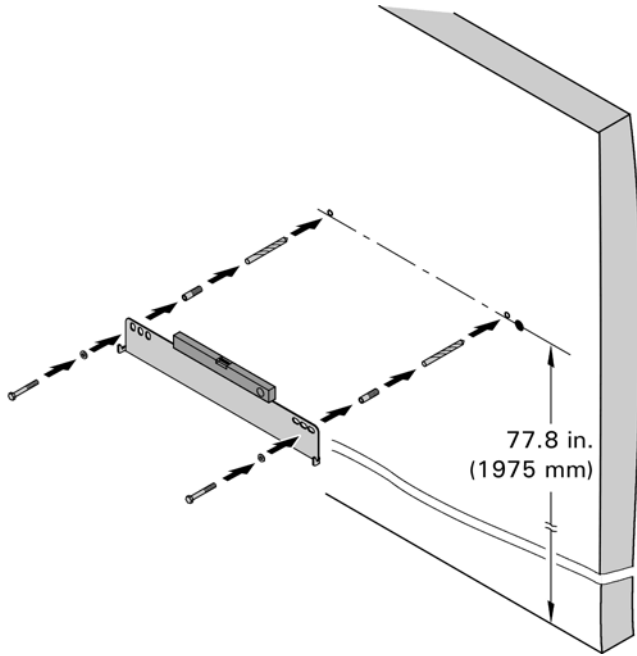

Fitting the wall mounting bracket

Following are the installation instructions for the mounting bracket on each material. See the instructions applicable to your installation requirements.

Installing the wall mounting bracket

The Vitodens 200-W B2HA can be wall-mounted on a concrete wall.

Note: The enclosed screws and rawl plugs are only suitable for concrete. For other construction materials, use bolts and anchors that are suitable for 220 lb (100 kg) loads.

Installation of mounting bracket on brick/concrete wall

1. Drill holes $\varnothing 31/64$ in. (12 mm).
2. Install rawl plugs and screw mounting bracket to wall.
3. Ensure the mounting bracket is level.

CAUTION

Whichever mounting method is used, ensure that the bracket is tightly and securely fastened to wall. Failure to secure boiler properly could cause boiler to loosen, posing a severe safety hazard.

Wall Mounting *(continued)*

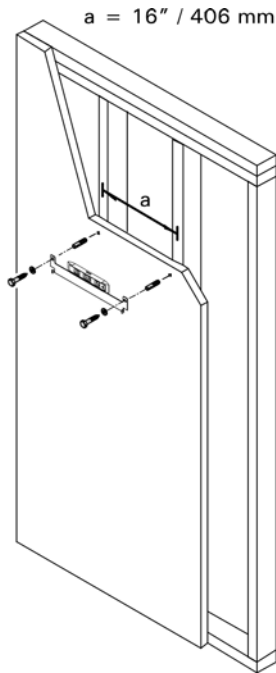

Boiler mounting bracket

Install the boiler mounting bracket to the wall studs. Ensure the mounting bracket is level.

To mount on wood or metal studs a cross bar or frame may be required as reinforcement. The wall and studs must be capable of supporting a minimum of 220 lb. (100 kg).

For construction materials, use fixings that are suitable for 220 lb (100 kg) loads.

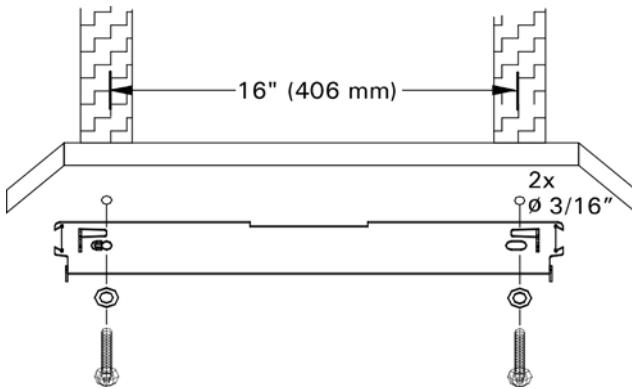

Installation on wood studs

Install mounting bracket on wood studs as per illustration. Drill $\frac{3}{16}$ in. pilot holes to insert mounting bolts. Ensure that holes are located in the center of each wood stud. Secure with bolts to wooden studs as shown.

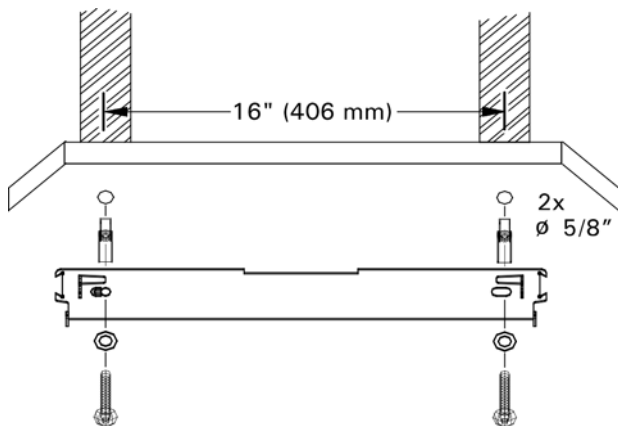

Installation on metal studs

Install mounting bracket on metal studs as per illustration. Drill $\frac{5}{8}$ in. pilot holes to insert anchors. Ensure that holes are located in the center of each metal stud. Use appropriate fasteners to mount to metal studs (not supplied). Secure with bolts to metal studs as shown. Ensure the mounting bracket is level.

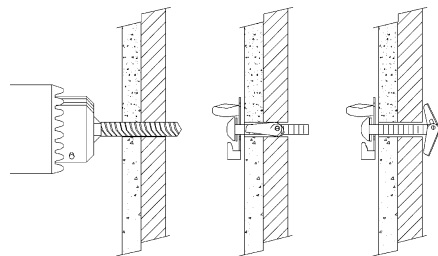

Wall Mounting *(continued)*

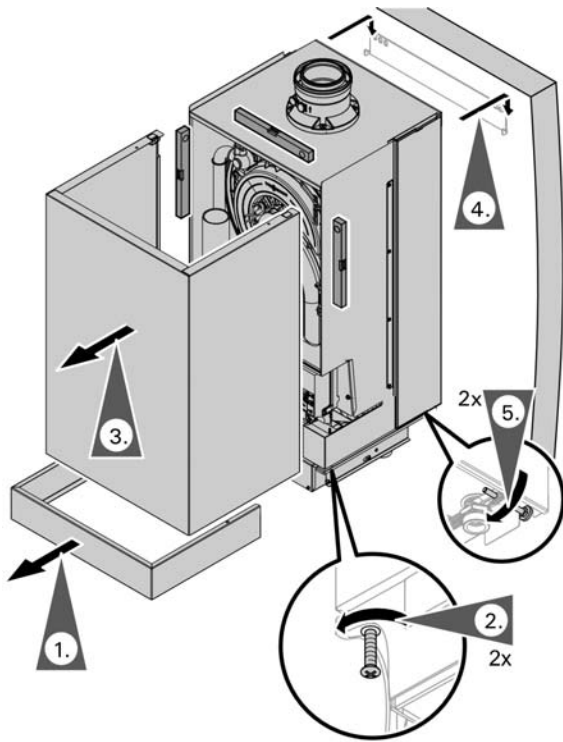

1. Remove the external accessories connection box cover.
2. Loosen the screws at the bottom of the boiler (do not remove completely).
3. Remove the front enclosure panel (lift up and pull away from the boiler).
4. Mount boiler onto the mounting bracket.
5. Adjust the levelling screws to ensure the boiler is level. Place the round bubble level on top of the boiler to verify.
Note: For draining of the condensate (see page 28).
6. Install supplied installation fittings as per layout (see page 11).

CAUTION

The boiler must be level both vertically and horizontally to ensure proper draining of the condensate.

Frame Mounting

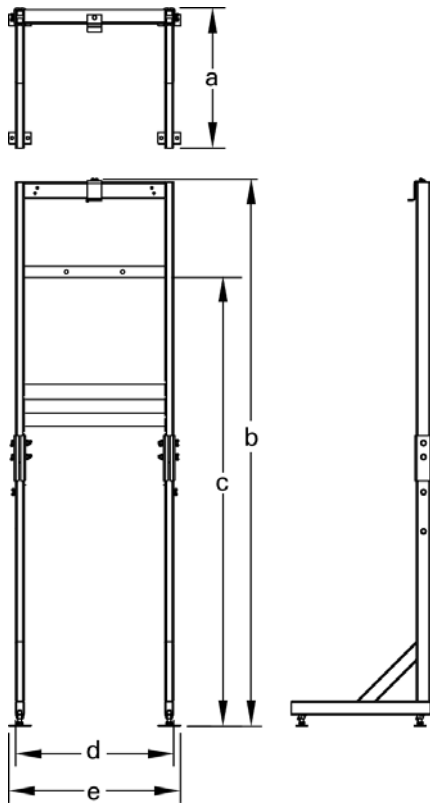

The boiler stand is used for free-standing installation of a single boiler within the mechanical room.

When using the boiler stand, ensure that the stand is securely fastened to the floor (recommended concrete expansion anchors are Hilti model KB-TZ 3/8 x 4 or equivalent).

a	in. (mm)	19 ⁵ / ₈ (500)
b	in. (mm)	76 ³ / ₄ ± 1/2 (1950 ± 12.7)
c	in. (mm)	63 ± 1/2 (1600 ± 12.7)
d	in. (mm)	22 (560)
e	in. (mm)	24 (610)

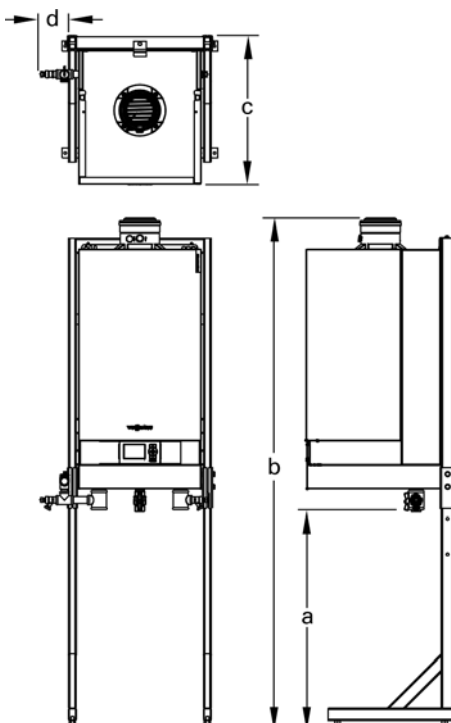

Vitodens 200-W		
B2HA 80 to 100, 285 to 352		
a * 1	in. (mm)	34 ¹ / ₄ (870)
b * 1	in. (mm)	79 ¹ / ₂ (2020)
c	in. (mm)	23 (585)
d	in. (mm)	5 ¹ / ₈ (130)

* 1 ± 1/2 in. (12.7 mm) for adjustment of the levelling feet.

Models B2HA 80 to 100, 285 to 352 Frame Mounting

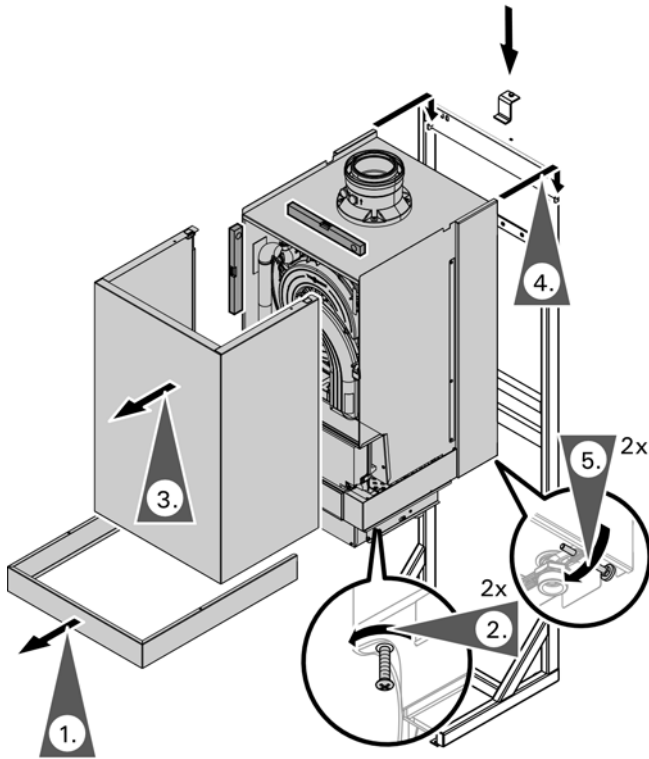

1. Remove the external accessories connection box cover.
2. Loosen the screws at the bottom of the boiler (do not remove completely).
3. Remove the front enclosure panel (lift up and pull away from the boiler).
4. Mount boiler onto the mounting bracket and ensure the boiler is securely mounted. Then install the holding bracket to the frame on top of the boiler.
5. Adjust the levelling screws to ensure the boiler is level.
6. Connect the boiler to the installation fittings.

CAUTION

The boiler must be level both vertically and horizontally to ensure proper draining of the condensate.

Connections

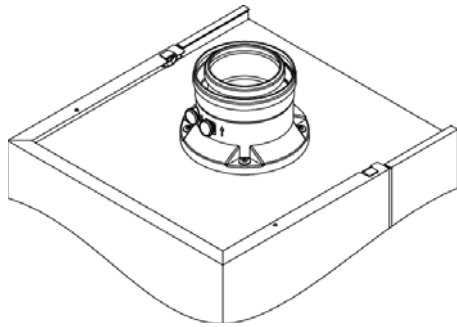

Connecting power

The Vitodens 200-W boiler has a external accessories connection box installed, which requires a 120VAC/12A power supply. Refer to the wiring diagram on page 47.

Boiler venting

The Vitodens 200-W B2HA boiler comes with a pre-installed vent pipe adaptor.

Run venting system, single-wall or coaxial, through the side wall or the roof, taking the shortest possible route and at a rising angle (min. 3°).

WARNING

Remove outer gasket if single wall (boiler room air dependant) venting system is used.

2 imperfect threads

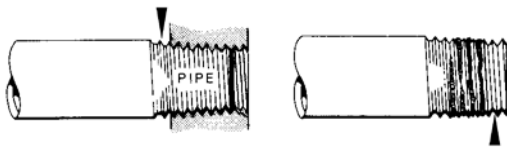

Leave 2 threads bare

Proper piping practice

Support piping by proper suspension method. Piping must not rest on or be supported by boiler. Use moderate amount of dope.

Manual gas shutoff

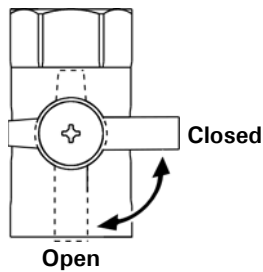

Gas shut-off valve connection

1. Make gas connections in accordance with codes CAN/CSA B149.1 and .2 or National Fuel Gas Code ANSI Z223.1/NFPA 54, as well as local codes.
2. Connect gas shutoff valve to the boiler gas connection.
3. Once connected close gas shutoff valve on boiler.



See following page for details on gas connection and piping.

Connections *(continued)*

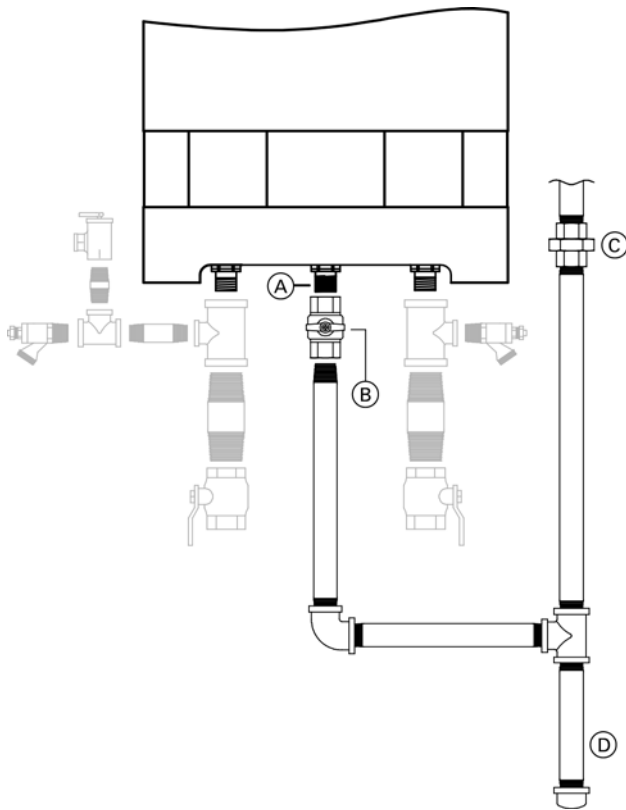

Legend

- (A) Gas connection \varnothing 1 in. (NPT)
- (B) Accessible manual gas shutoff valve
- (C) Ground joint union
- (D) Drip leg

Gas connection and piping

1. Refer to current CAN/CSA B149.1 and .2 or National Fuel Gas Code ANSI Z223.1/NFPA 54, as well as local codes for gas piping requirements and sizing. Pipe size to the boiler must be determined based on:
 - pipe length
 - number of fittings
 - type of gas
 - maximum input requirements of all gas appliances in the residence.

IMPORTANT

Design piping layout in such a way that piping does not interfere with serviceable components.

2. Before connecting boiler to gas line, install ground joint union, capped drip leg and a manual equipment shutoff valve as shown. Valves must be listed by a nationally recognized testing agency. Make boiler gas connection as shown.
3. Perform gas piping pressure test as described in the following subsection.

IMPORTANT

Max. gas supply pressure: 14 "w.c.

4. Identify shutoff valves as such with a tab and familiarize operator / ultimate owner of boiler with these valves.



See Vitodens 200-W B2HA Service Instructions for applicable system coding information.

! WARNING

The gas supply piping must be leak tested before placing the boiler in operation.

! CAUTION

Ensure that gas piping is large enough for all appliances in the residence. No noticeable gas pressure drop in the gas line must occur when any unit (or combination of units) lights or runs.

IMPORTANT

Regarding operation with LPG, we recommend the installation of an external safety solenoid valve when installing the boiler in rooms below ground level.

Connections *(continued)*

Gas piping pressure test

When performing the gas piping pressure test, ensure the following requirements are met.

WARNING
Never check for gas leaks with an open flame.

WARNING
Exposing boiler gas pressure regulator and gas valve to extreme pressures renders warranty null and void.

IMPORTANT

½ psig = 14 "w.c.

1. Isolate the boiler from the gas supply piping system using the individual manual shutoff valve during pressure tests equal to or less than ½ psig (14 "w.c.)
2. The boiler and its individual shutoff valve must be disconnected from the gas supply piping system during any pressure testing of that system at test pressures in excess of ½ psig (14 "w.c.)
3. Perform leak test.
Use approved liquid spray solution for bubble test. Ensure that no liquid is sprayed on any electrical components, wires or connectors. Do not allow leak detection fluid to contact gas valve regulator or regulator vent opening.
4. Correct any and all deficiencies.
5. Remove air from gas line.

Heating water connections

1. Thoroughly flush heating system (particularly before connecting the boiler to an existing system).
2. Connect boiler to the heating system.

WARNING
Exposing the boiler to pressures and temperatures in excess of those listed will result in damages, and will render warranty null and void.

Max. allowable working pressure (MAWP)..4 bar (60 psig)
Max. boiler water temperature.....210°F (99°C)

3. Connect field supplied nipples and tees as shown for DHW supply and return.

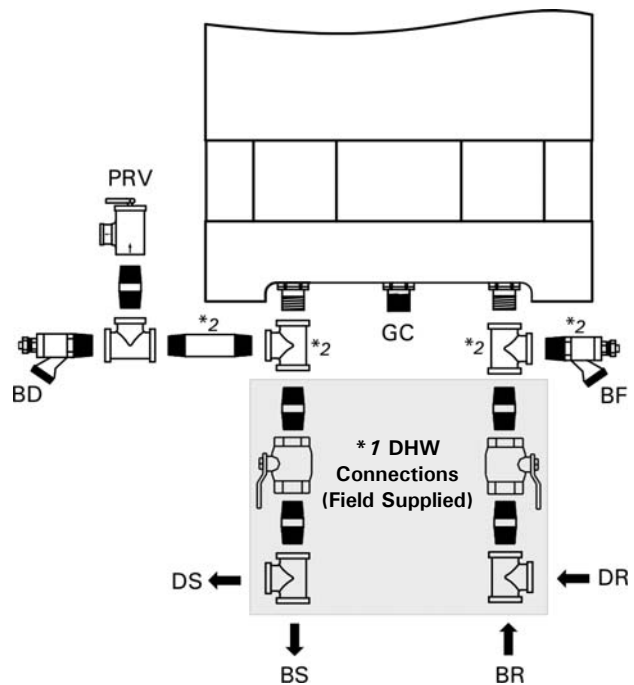

Legend

- DR Boiler heating return for domestic hot water production
- DS Boiler heating supply for domestic hot water production
- BD Boiler Drain
- BF Boiler Fill
- BR Boiler Return
- BS Boiler Supply
- GC Gas Connection
- PRV Pressure Relief Valve
- *1 See page 43 for alternate DHW connection.

IMPORTANT

Apply sufficient amount of thread sealant (supplied) when making the connections.

Connections *(continued)*

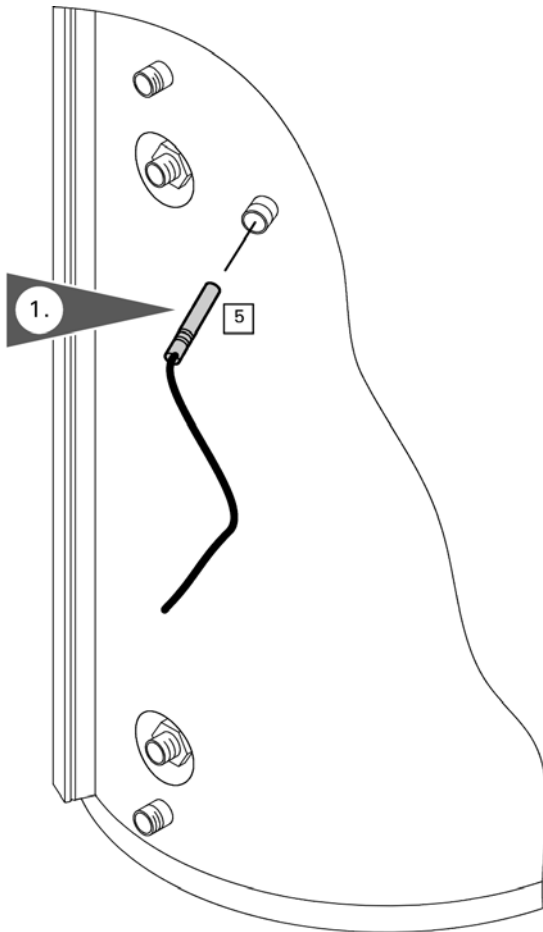

DHW storage tank information

The DHW water tank sensor is required when using a stand-alone DHW storage tank with the Vitodens 200-W B2HA heating boiler. It comprises the sensor only required for the connection of a stand-alone tank. All other required piping connections are field supplied.



See Vitodens 200-W B2HA Service Instructions for applicable system coding information.

IMPORTANT

Apply sufficient amount of thread sealant (supplied) when making the connections.

Making the DHW connections

1. With a Vitocell 100 and 300 series tanks locate the DHW temperature sensor well and install the DHW temperature sensor [5] using the installation instructions provided with the DHW storage tanks.

IMPORTANT

Follow the Installation Instructions supplied with the Viessmann DHW storage tank when mounting and securing DHW tank temperature sensor [5].

! WARNING

If a DHW storage tank other than a Viessmann Vitocell 100 or 300 tank is used, the installer must verify proper operation of the Viessmann DHW tank temperature sensor with original manufacturer of the tank. Viessmann strongly recommends the installation of a temperature tempering valve in the DHW supply line.

Connections *(continued)*

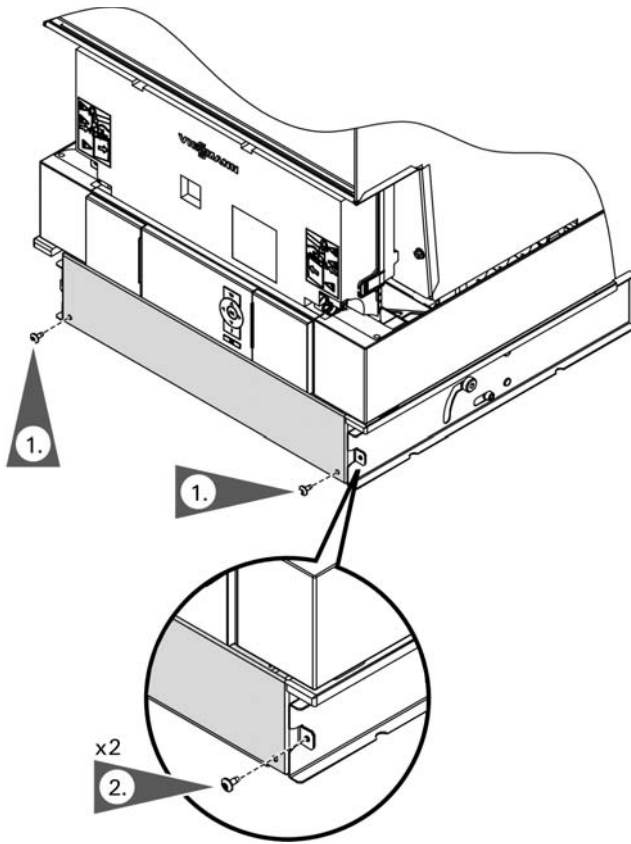

Accessing the control unit connections

1. Remove both screws from the external accessory connection box front plate and set aside.
2. Loosen both retaining screws as shown (do not remove).

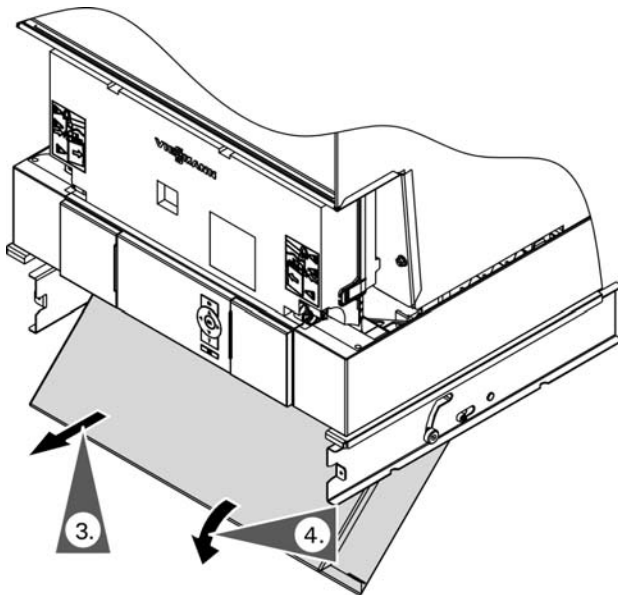

3. Pull the external accessory connection box forward until the retaining screws are clear of the guides.
4. Swing the external accessory connection box down.

Connections *(continued)*

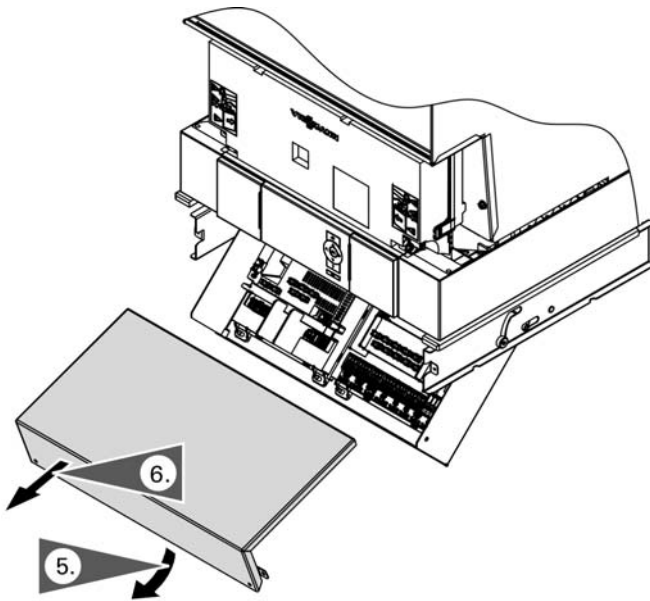

5. Tilt the bottom of the external accessory connection box cover forward.
6. Pull the cover up to clear the locating pins and out to remove, then set aside.

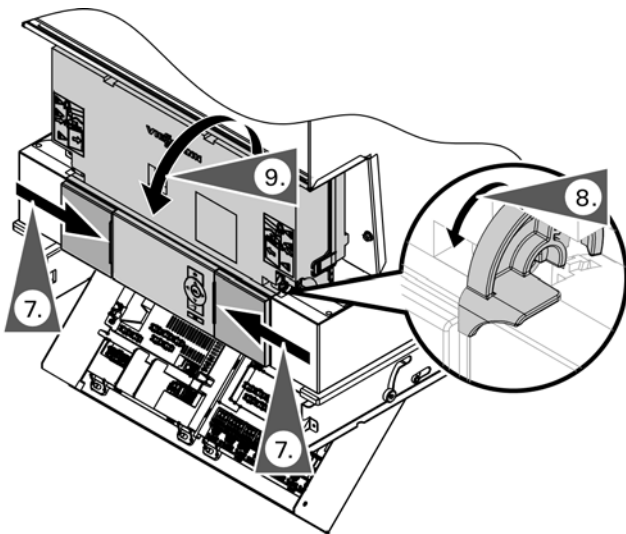

7. Slide both sides of the programming unit cover closed.
8. Release the hinged hooks located on both sides of the control unit.
9. To open hinged cover, lift cover and then fold down the control unit.

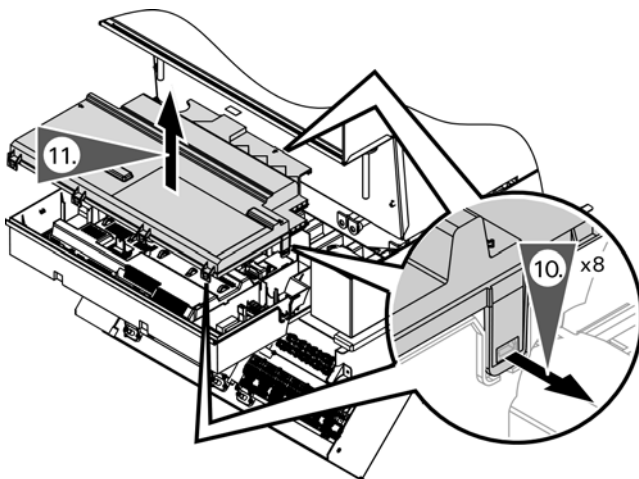

10. Release locking tabs as shown.
11. Remove cover.

Connections *(continued)*

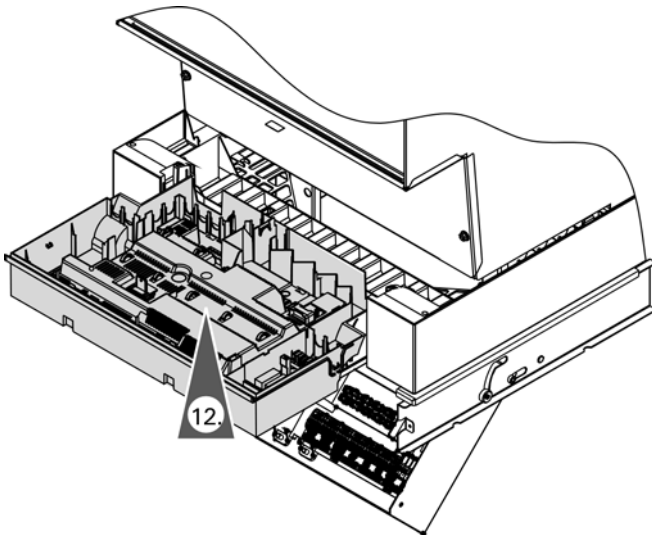

12. Route all connecting cables to the appropriate areas and secure the cables to the control base using existing strain reliefs as shown.

CAUTION

When running and securing connecting cables on site, ensure that the maximum permissible temperatures of the cables are not exceeded.



Electronic modules can be damaged by electrostatic discharges. Before commencing work, touch grounded objects (such as heating or water pipes) to discharge static loads.

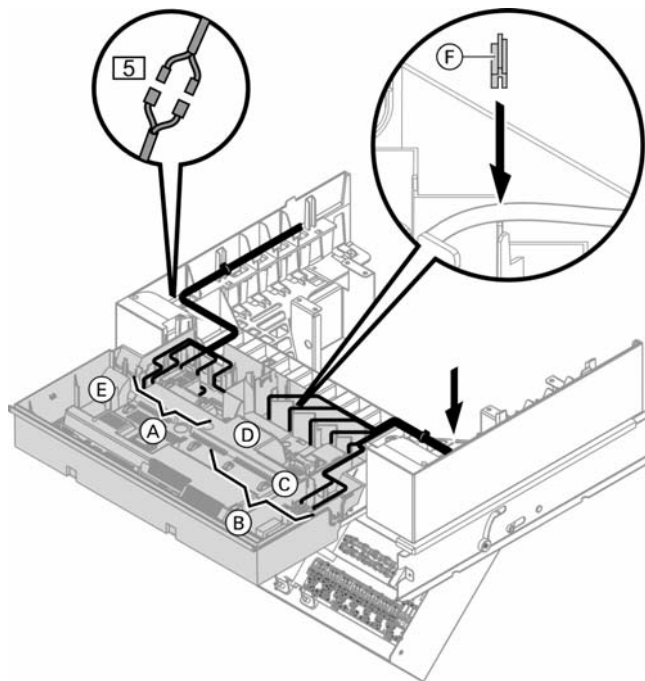

Routing the connecting cables

Note: If connecting cables touch hot components they will be damaged. When routing and securing connecting cables on site, ensure that the maximum permissible temperatures for these cables are not exceeded.

Remove the existing cable grommet when using larger cross-sections [up to 9/16 in. (Ø 14 mm)]. Secure the cable with the cable grommet plugged into the lower casing section (black).

Legend

- (A) Low voltage connections
- (B) 120V connections
- (C) Internal extension
- (D) Main PCB
- (E) Communication module (accessory)
- (F) Cable grommet for power cable
- [5] Plugs for connecting the DHW temperature sensor to the cable harness

Connections *(continued)*

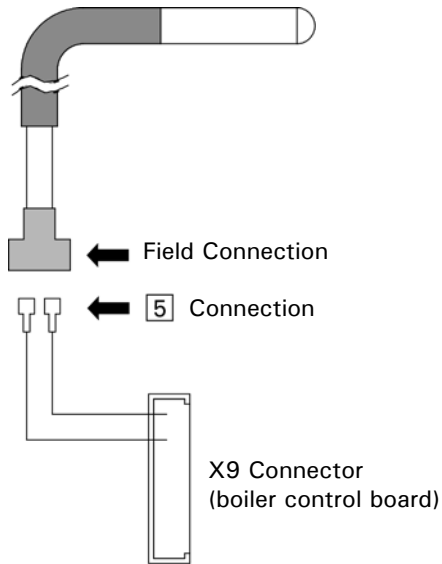

Connecting DHW sensor

1. Attach the DHW sensor to the quick connect plugs provided from the boiler control board (see page 24).



Install DHW tank temperature sensor as described in the Vitocell Installation Instructions supplied with the DHW storage tank.

Setting altitude parameters

In the factory default setting, the boiler is equipped to operate in altitudes of up to 5,000 ft. (1,500 m).

Altitude can be set using coding address 93 (in coding level 2 General).



See Vitodens 200-W B2HA Service Instructions for applicable system coding information.

Connections *(continued)*

Control base

Note: See wiring diagram on page 47 for connection to the external accessory connection box.

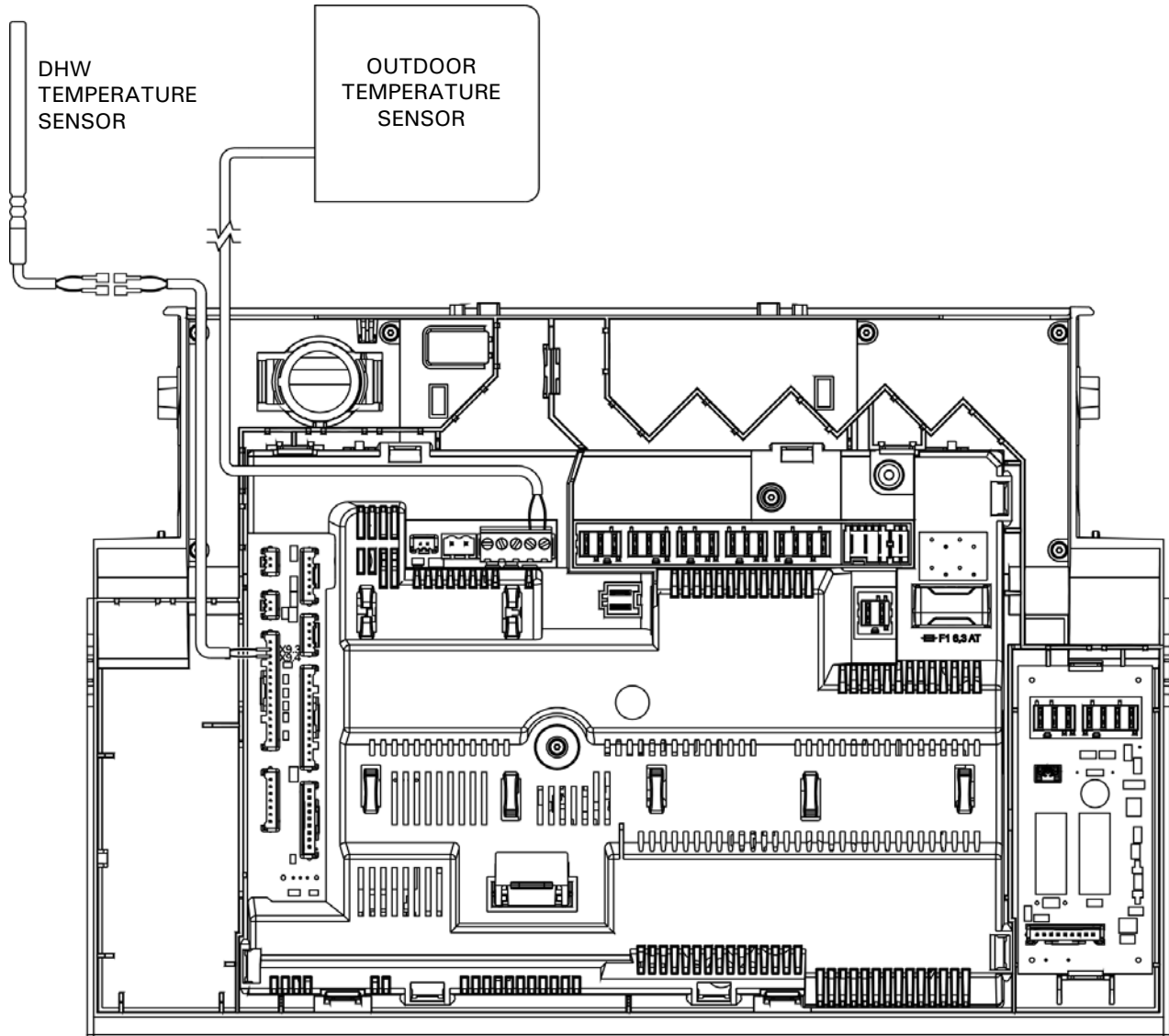

Connections *(continued)*

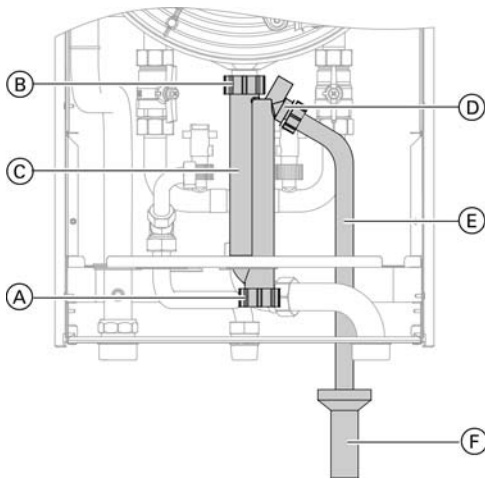

Condensate Connection for Vitodens 200-W, models B2HA 80, 88, 100, 285, 311, 352

Legend

- (A) Cap
- (B) Union nut
- (C) Siphon trap
- (D) Retaining clip
- (E) Flexible discharge tubing
- (F) Discharge tube

Condensate installation example:

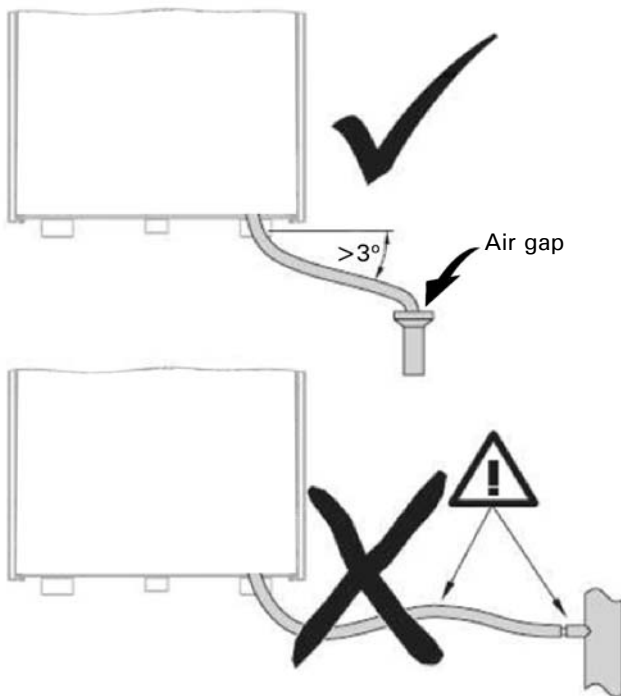

Condensate connection

The Vitodens 200-W B2HA boiler comes with a built-in condensate trap. An external trap is not required when connecting the field drain to flexible discharge tubing. Discharge tubing (field supplied) must be of 1 in. diameter. Use CPVC, PVC or other material approved by codes listed below.

The drain pipe and fittings must conform to ANSI standards and ASTM D1785 or D2846. CPVC or PVC cement and primer must conform to ASTM D2564 or F493. In Canada use CSA or ULC listed schedule 40 CPVC or PVC drain pipe, fittings and cement.

If the condensate outlet of the Vitodens 200-W B2HA boiler is lower than the drain, a condensate pump must be installed. Select a pump which is approved for condensing boiler applications. To avoid condensate spillage, select a pump with an overflow switch. The drain connection must terminate into an open or vented drain as close to the boiler as possible to prevent siphoning of the boiler drain.

1. Install the condensate drain pipe with a suitable gradient. Pull the condensate hose so far out of the boiler that no unnecessary bends are created inside the boiler. Check tightness of siphon connection.

IMPORTANT

As shipped, the flexible discharge tubing (E) will be found to be pushed up inside the boiler housing. Ensure the condensate drain pipe is pulled down and positioned to allow the condensate to properly drain.

2. Discharge condensate from the boiler into the vented drainage system, either directly or (if required) via a neutralization unit (accessory).



Installation Instructions of Neutralization Unit (if applicable)

IMPORTANT

Pipe ventilation must take place between the siphon trap and the neutralization unit (if applicable).

IMPORTANT

Do not connect the drain pipe from any other appliance, such as water softener backwash pipe, to Vitodens condensate drain pipe.

3. Ensure the condensate discharge tubing is vented to the atmosphere prior to being plumbed into the neutralization unit.

Safety Connections

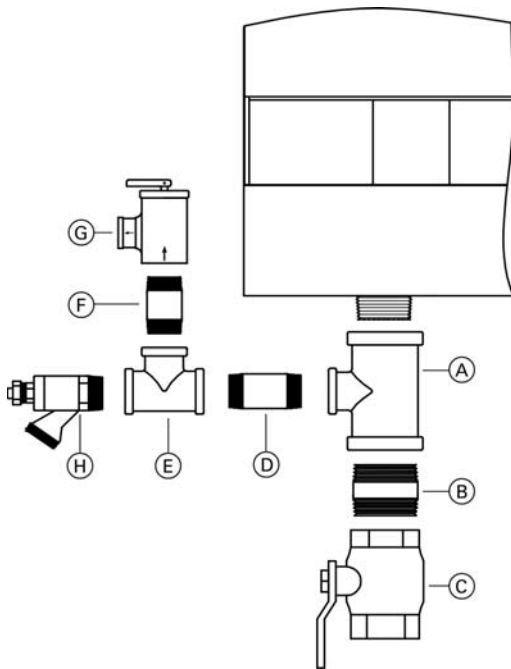

Legend

- (A) Reducing tee, 1 1/2 in. x 1 1/2 in. x 3/4 in.
- (B) Nipple, length 1 1/2 in. x 2 1/2 in. (field supplied)
- (C) Isolation valve, 1 1/2 in. (field supplied)
- (D) Nipple, length 3 1/2 in. x 3/4 in.
- (E) Tee 3/4 in.
- (F) Nipple, length 1 1/2 in. x 3/4 in.
- (G) Pressure relief valve, 3/4 in. NPT
- (H) Drain valve connection, 3/4 in.

Minimum connection diameters:
 Pressure relief valve..... 3/4 in.
 Discharge pipe..... 3/4 in.
 Piping to precharged expansion tank..(field supplied)

Installing boiler safety devices

1. Remove loosely pre-assembled combination pressure relief valve and drain valve assembly.
2. Apply sufficient amount of pipe sealant to both ends of all pipe fittings (B), (D), (F) and (H) and install onto tees (A), and (E).
3. Install pressure relief valve (F) and isolation valve (C) and tighten.
4. Install discharge pipe on pressure relief valve in such a way that...
 - the end of the pipe is not threaded.
 - the pressure relief discharge pipe extends to a floor drain and ends approximately 6 in. (150 mm) above the drain.
 Ensure that...
 - there is no shutoff valve installed in the discharge pipe.
 - discharge pipe diameter is not reduced.
 - discharge is not piped to outdoors.

IMPORTANT

Install the (approved) factory supplied pressure relief valve.

Removal of air from the system must occur via use of air vent(s) in the system supply. To ensure the boiler can be purged of all air, ensure supply/return water lines do not contain restrictive piping where air could be trapped.

! WARNING

Do not install an isolation valve between boiler and pressure relief valve.

The discharge pipe for the pressure relief valve must be oriented to prevent scalding of attendants.

Pipe pressure relief valve discharge pipe close to floor drain. Never pipe discharge pipe to the outdoors.

Safety Connections *(continued)*

Low water cut-off

A low water cut-off device may be required by local codes. If required, a low water cut-off device of an approved type (field supplied), is to be installed as per the manufacturers instructions. DO NOT install an isolation valve between the boiler and the low water cut-off device.

Waterside Flow

Waterside flow (primary circuit)

The Vitodens 200-W, B2HA is designed for closed loop, forced circulation hot water heating systems only.

Use standard friction loss method for pipe sizing. Observe boiler maximum and minimum flow rate limitations. If system flow rate exceeds boiler maximum flow rate (as stated above), falls below the minimum flow rate or if system flow rate is unknown, Viessmann strongly recommends the installation of a low-loss header.

Once the low-loss header is connected, the built-in low-loss header logic of the Vitodens 200-W boiler ensures the required Δt across the system through the sensory communication between the low-loss header and the boiler.

An alternative method may be used, such as primary secondary piping using closely spaced tees. A low-loss header offers additional benefits not provided by a pair of closely spaced tees. Viessmann therefore strongly recommends and prefers the use of a low-loss header over closely spaced tees. Refer to the Technical Data manual for low-loss header information.

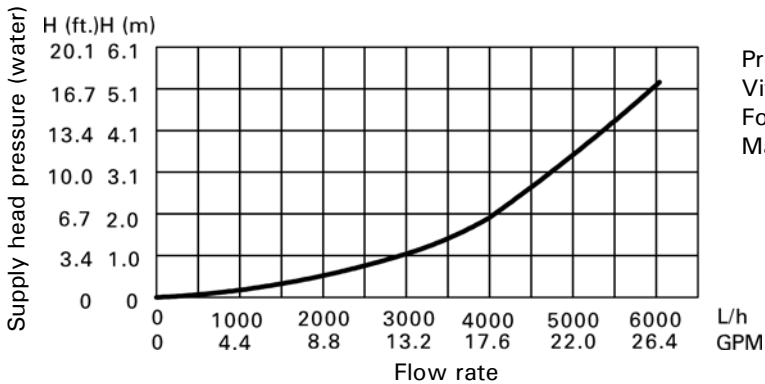

Pressure drop (primary circuit) for:
 Vitodens 200-W, B2HA 80, 88, 100, 285, 311, 352
 For sizing an on-site circulation system.
 Max. flow rate 25 USGPM (5700 L/h)

Waterside flow *(continued)*

Boiler max. flow rate for B2HA 80, 285; 25 GPM (5700 L/h)

Model B2HA 80, 285	1 boiler	2 boilers	3 boilers	4 boilers	5 boilers	6 boilers	7 boilers	8 boilers
Output (NG/LPG) MBH	260	520	780	1040	1300	1560	1820	3960
Δt for NG/LPG								
20°F rise GPM (L/h)	26 (5905)	52 (11811)	78 (17717)	104 (23223)	130 (29526)	156 (35434)	182 (41340)	208 (47246)
25°F rise GPM (L/h)	*1 20.8 (4724)	41.6 (9449)	62.4 (14174)	83.2 (18898)	104 (23621)	125 (28347)	145.6 (33072)	166.4 (37797)
30°F rise GPM (L/h)	*1 17.3 (3937)	35 (7874)	52 (11811)	69.3 (15749)	87 (19684)	104 (23623)	121.3 (27560)	138.7 (31497)
35°F rise GPM (L/h)	*1 15 (3374)	30 (6749)	44.6 (10124)	59.4 (13499)	74.3 (16872)	89 (20248)	104 (23623)	119 (26997)
40°F rise GPM (L/h)	*1 13 (2953)	26 (5906)	39 (8859)	52 (11811)	65 (14763)	78 (17717)	91 (20670)	104 (23623)

*1 Low loss header optional

Boiler max. flow rate for B2HA 88, 311; 25 GPM (5700 L/h)

Model B2HA 88, 311	1 boiler	2 boilers	3 boilers	4 boilers	5 boilers	6 boilers	7 boilers	8 boilers
Output (NG/LPG) MBH	260	520	780	1040	1300	1560	1820	3960
Δt for NG/LPG								
20°F rise GPM (L/h)	29.4 (6677)	58 (13355)	88.2 (20032)	117.6 (26709)	147.0 (33387)	176.4 (40064)	205.8 (46741)	235.2 (53419)
25°F rise GPM (L/h)	*1 23.5 (5342)	47.0 (10684)	70.6 (16026)	94.1 (21367)	117.6 (26079)	141.1 (32051)	164.6 (37393)	188.2 (42735)
30°F rise GPM (L/h)	*1 19.6 (4452)	39.2 (8903)	58.8 (13355)	78.4 (17806)	98.0 (22258)	117.6 (26709)	137.2 (31161)	156.8 (35612)
35°F rise GPM (L/h)	*1 16.8 (3816)	33.6 (7631)	50.4 (11447)	67.2 (15262)	84.0 (19078)	100.8 (22894)	117.6 (26709)	134.4 (30525)
40°F rise GPM (L/h)	*1 14.7 (3339)	29.4 (6677)	44.1 (10016)	58.8 (13355)	73.5 (16693)	88.2 (20032)	102.9 (23371)	117.6 (26709)

*1 Low loss header optional

Boiler max. flow rate for B2HA 100, 352; 25 GPM (5700 L/h)

Model B2HA 100, 352	1 boiler	2 boilers	3 boilers	4 boilers	5 boilers	6 boilers	7 boilers	8 boilers
Output (NG/LPG) MBH	333	666	999	1322	1665	1998	2331	2664
Δt for NG/LPG								
20°F rise GPM (L/h)	33.3 (7563)	66.6 (15128)	100 (22692)	133 (30255)	166.5 (37816)	200 (45383)	233 (52947)	266.4 (60510)
25°F rise GPM (L/h)	26.6 (6051)	53.3 (12102)	80 (18153)	106.6 (24204)	133 (30253)	160 (36307)	187 (42377)	213 (48409)
30°F rise GPM (L/h)	*1 22.2 (5042)	44.4 (10085)	66.6 (15128)	89 (20170)	111 (25211)	133 (30255)	155.4 (35298)	178 (40341)
35°F rise GPM (L/h)	*1 19 (4322)	38.1 (8644)	57 (12967)	76 (17289)	95 (21609)	114 (25933)	133 (30255)	152 (34578)
40°F rise GPM (L/h)	*1 16.7 (3781.6)	33.3 (7564)	50 (11346)	66.6 (15128)	83 (18908)	100 (22692)	117 (26473)	133 (30255)

*1 Low loss header optional

Installation Examples

General

The schematics on the following pages are to be seen as guidelines only. They further do not display all system varieties, safety devices, or concepts possible. Specific system layouts may be further discussed with the local Viessmann sales representative office.

Clearances

A minimum of 2 in. (51 mm) circumferential clearance from non-insulated hot water pipes to combustible construction must be maintained. In cases where the pipes are insulated with pipe insulation of appropriate and sufficient thickness and insulation values, the above clearance may be reduced to 0 in. (refer to local gas codes).

CAUTION

For underfloor heating applications, an additional immersion or strap-on aquastat must be installed in the low temperature underfloor loop (downstream of the mixing valve) to de-energize the pump and/or boiler to prevent overheating. High water temperatures can damage concrete slabs.

IMPORTANT

The examples on the following pages depict possible piping layouts of the Vitodens 200-W B2HA boiler equipped with Viessmann System Technology. For boiler and tank combinations, please install only feasible combinations listed in the Viessmann Price List.

Please note that the following examples are simplified conceptual drawings only!

Piping and necessary componentry must be field verified.

A low water cut-off (LWCO) must be installed where required by local codes.

Proper installation and functionality in the field is the responsibility of the heating contractor.

WARNING

If a DHW storage tank other than a Viessmann Vitocell 100 or 300 tank is used, the installer must verify proper operation of the Viessmann DHW tank temperature sensor with the original manufacturer of the tank. Viessmann strongly recommends the installation of a temperature tempering valve in the DHW supply line.

IMPORTANT

DHW supply and return piping between boiler DHW connections and the Viessmann DHW tank connections, shall be a minimum of 1¼ in. pipe size. This will ensure the residual head of the field supplied pump is fully utilized to overcome the resistance of the DHW heat exchanger coil and to provide sufficient water flow to the boiler heat exchanger.

In non-Viessmann DHW tank applications, perform, in addition to the above, accurate calculations for DHW tank coil pressure drop versus boiler pump (field supplied) residual head to ensure sufficient water flow to the boiler heat exchanger. Failure to heed the above instructions may cause boiler short-cycling and inadequate DHW supply.

Note: In the following piping layout examples all pumps are field supplied.

System Layout 1

Vitodens 200-W, B2HA with a direct-connected heating circuit

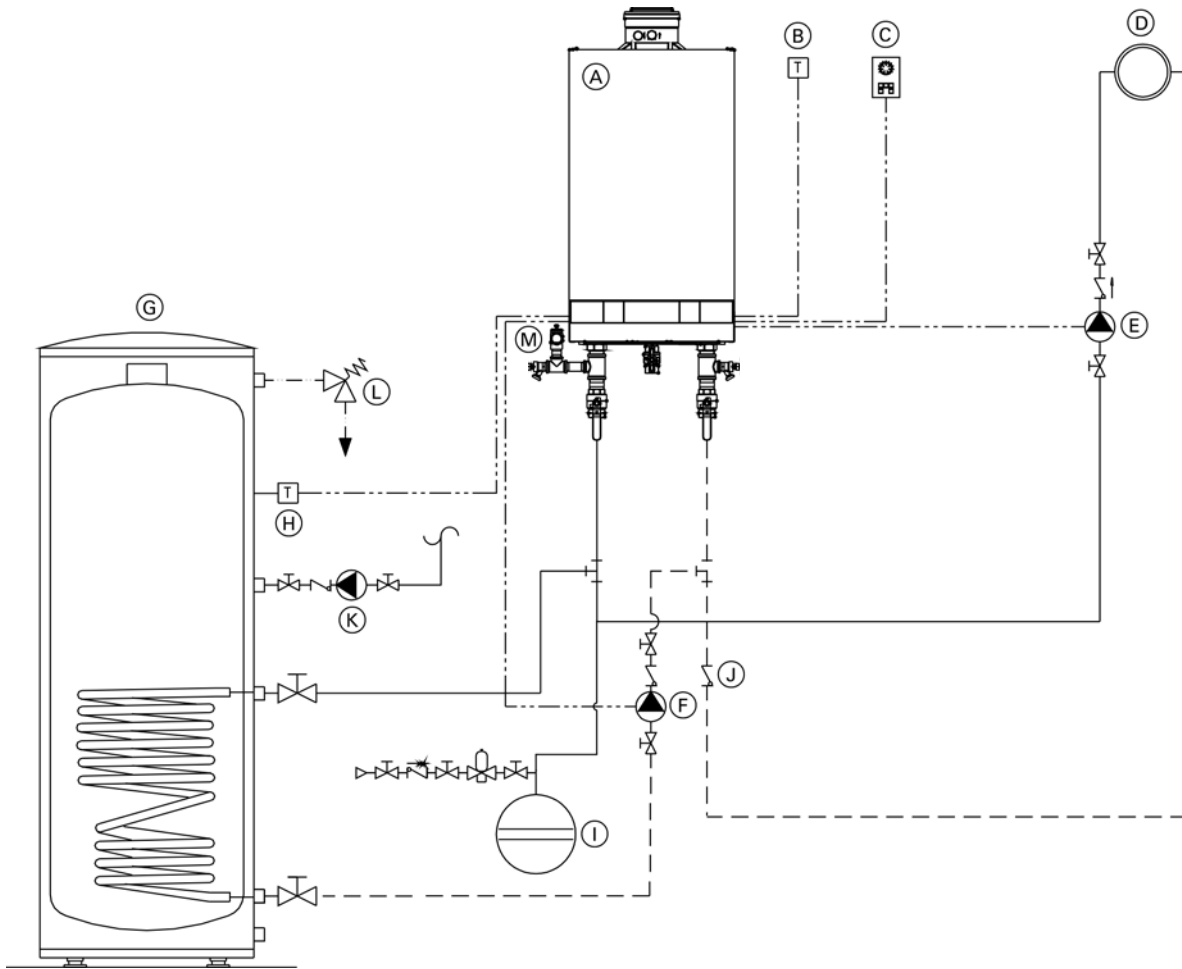

Legend

- (A) Vitodens 200-W B2HA boiler with Vitotronic 200, HO1B outdoor reset control
 - (B) Outdoor temperature sensor [1]
 - (C) Vitotrol remote (optional)
 - (D) Heating circuit
 - (E) Heating circuit pump [20]
 - (F) DHW circulating pump [21]
 - (G) DHW storage tank
 - (H) DHW tank temperature sensor [5]
 - (I) Expansion tank
 - (J) Flow check valve
 - (K) DHW recirculation pump [28/20] *
 - (L) Temperature and pressure relief valve
 - (M) Pressure relief valve
- * Function based on coding of address 53

Installation of ...

- radiator heating circuit (high-temp. circuit)
- DHW production

... with the following flow conditions:

The flow rate of the heating circuit is less than the maximum possible water flow rate of the Vitodens 200-W B2HA boiler (see page 30 for maximum water flow rate of boiler).

The use of a low-loss header is strongly recommended if the maximum water flow rate in the application concerned exceeds the values shown in the applicable table on page 31, or if the system flow rates are unknown. The low-loss header is available as accessory part.

See following pages for installation examples with a low-loss header.

IMPORTANT

DHW circulating pump (F) must pump into the Vitodens 200-W boiler (as illustrated).

System Layout 2

Vitodens 200-W, B2HA with one heating circuit and low-loss header

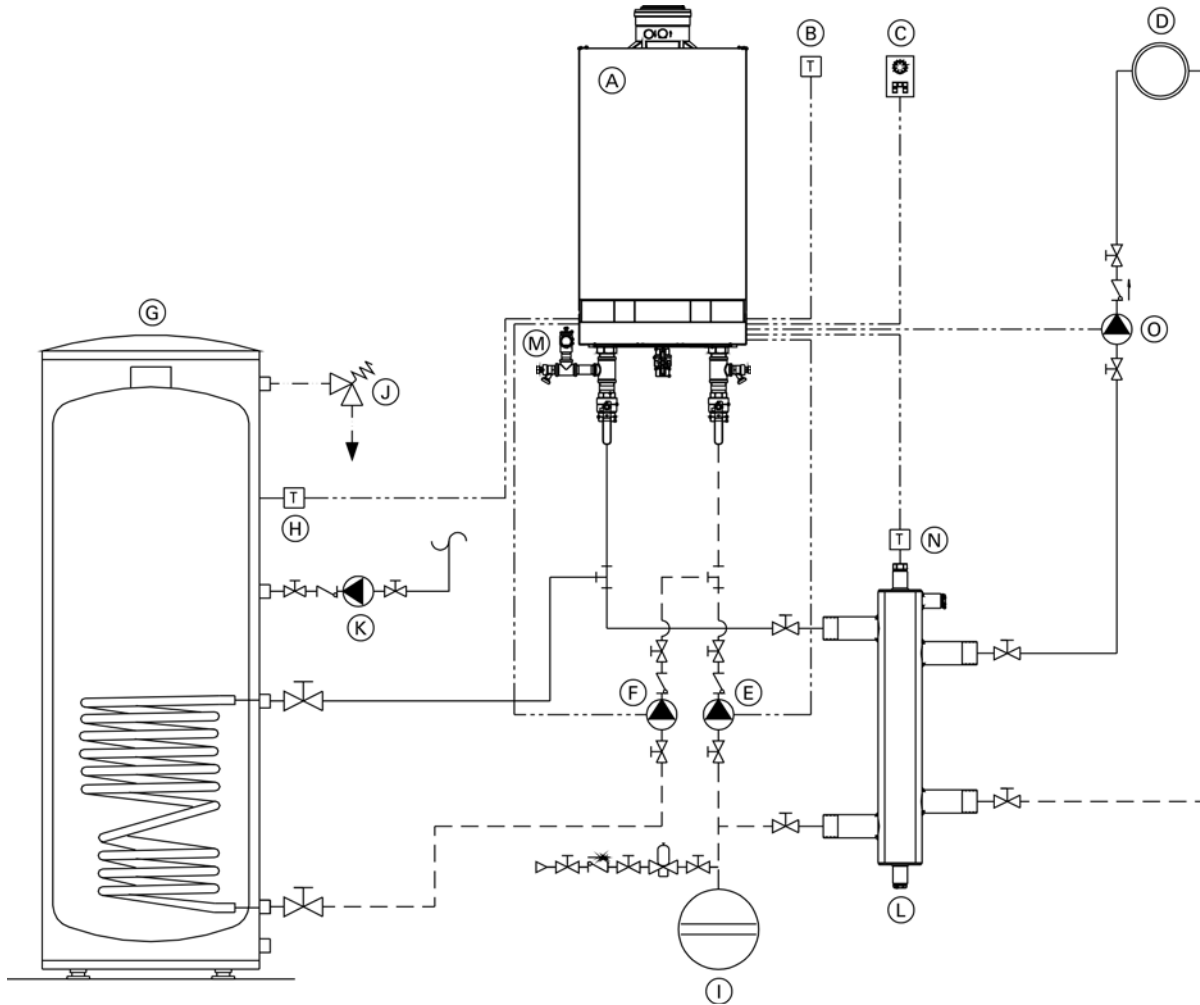

Legend

- (A) Vitodens 200-W B2HA boiler with Vitotronic 200, HO1B outdoor reset control
- (B) Outdoor temperature sensor [1]
- (C) Vitotrol remote (optional)
- (D) Heating circuit
- (E) Boiler pump [20]
- (F) DHW circulating pump [21]
- (G) DHW storage tank
- (H) DHW tank temperature sensor [5]
- (I) Expansion tank
- (J) Temperature and pressure relief valve
- (K) DHW recirculation pump [28/20] *
- (L) Low-loss header
- (M) Pressure relief valve
- (N) Viessmann temperature sensor for low-loss header [2]
- (O) Heating circuit pump [28/20] *

* Function based on coding of address 53

Installation of ...

- radiator heating circuit (high-temp. circuit)
- DHW production

... with the following flow conditions:

The flow rate of the heating circuit is greater than the maximum possible water flow rate of the Vitodens 200-W B2HA boiler (see page 30 for maximum water flow rate of boiler).

The use of a low-loss header is strongly recommended if the maximum water flow rate in the application concerned exceeds the values shown on page 31, or if the system flow rates are unknown.

The low-loss header is available as accessory part.

IMPORTANT

Please note location of expansion tank.

DHW circulating pump (F) must pump into the Vitodens 200-W B2HA boiler (as illustrated).

System Layout 3

Vitodens 200-W, B2HA with...

- DHW storage tank
- one heating circuit with mixing valve and system separation

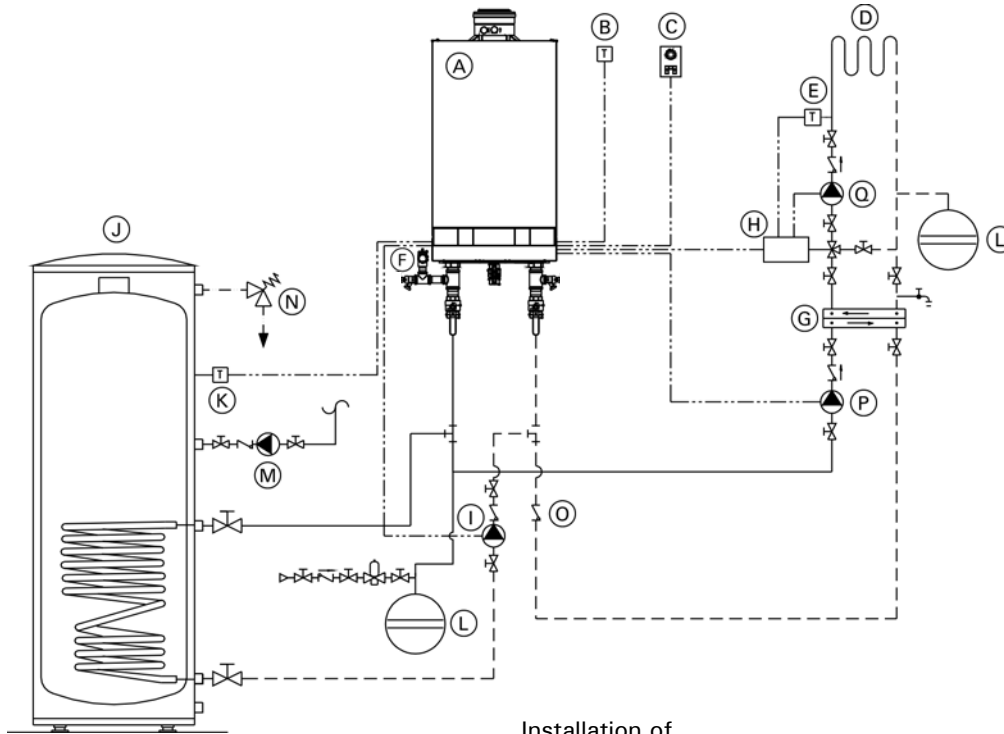

Legend

- (A) Vitodens 200-W B2HA boiler with Vitotronic 200, HO1B outdoor reset control
- (B) Outdoor temperature [1]
- (C) Vitotrol remote (optional)
- (D) Underfloor heating circuit
- (E) Mixing valve temperature sensor [2]
- (F) Pressure relief valve
- (G) Plate heat exchanger for system separation
- (H) Accessory kit for heating circuit with mixing valve
- (I) DHW circulating pump [21]
- (J) DHW storage tank
- (K) DHW tank temperature sensor [5]
- (L) Expansion tank
- (M) DHW recirculation pump [28/20] *
- (N) Temperature and pressure relief valve
- (O) Flow check valve
- (P) Heating circuit pump [20]
- (Q) Heating circuit pump

* Function based on coding of address 53

IMPORTANT

DHW circulating pump must pump (I) into the Vitodens 200-W B2HA boiler (as illustrated).

Installation of ...

- underfloor heating circuit with 3-way mixing valve and system separation (low-temp. circuit)
- DHW production

... with the following flow conditions:

The flow rate of the heating circuit is less than the maximum possible water flow rate of the Vitodens 200-W B2HA boiler.

See page 30 for maximum water flow rate of the Vitodens 200-W B2HA boilers. The use of a low-loss header is recommended if the system water flow rate is unknown. See the Technical Data Manual.

The low-loss header is available as accessory part.

See following pages for installation examples with a low-loss header.

IMPORTANT

System separation is required of underfloor heating systems employing non-oxygen diffusion barrier tubing. All components on the secondary side of the heat exchanger must be made of corrosion-resistant materials.

IMPORTANT

Sizing of field-supplied pump (P) is critical for proper boiler operation in this system layout. See page 30 for the supply head pressure drop of the boiler. An undersized pump may cause short-cycling and/or improper operation of the boiler. Viessmann **STRONGLY** recommends using a low-loss header and a boiler pump in this system layout.

System Layout 4

Vitodens 200-W, B2HA with...

- DHW storage tank
- one direct-connected heating circuit
- one heating circuit with a mixing valve

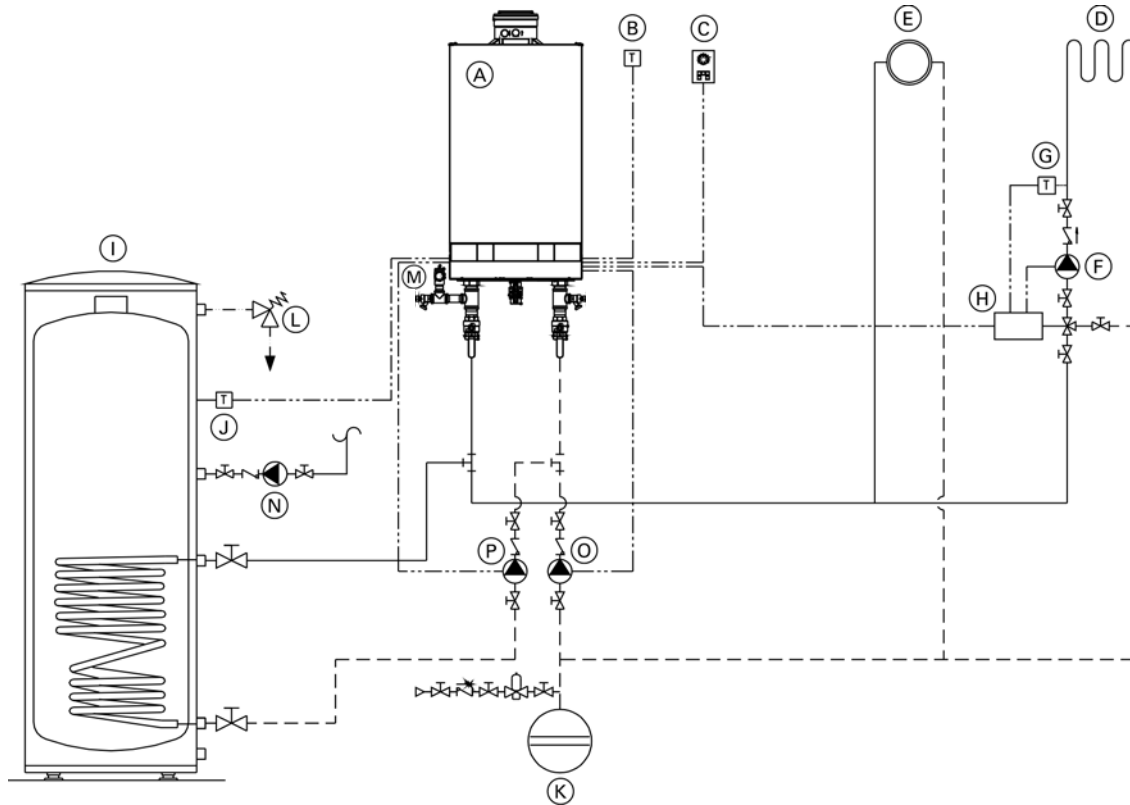

Legend

- (A) Vitodens 200-W B2HA boiler with Vitotronic 200, HO1B outdoor reset control
- (B) Outdoor temperature sensor [1]
- (C) Vitotrol remote (optional)
- (D) Under floor heating circuit
- (E) Radiator heating circuit
- (F) Heating circuit pump
- (G) Mixing valve temperature sensor [2]
- (H) Accessory kit for heating circuit with mixing valve
- (I) Domestic hot water storage tank
- (J) DHW tank temperature sensor [5]
- (K) Expansion tank
- (L) Temperature and pressure relief valve
- (M) Pressure relief valve
- (N) DHW recirculation pump [28/20] *
- (O) Boiler pump [20]
- (P) DHW circulating pump [21]

* Function based on coding of address 53

IMPORTANT

DHW circulating pump (P) must pump into the Vitodens 200-W B2HA boiler (as illustrated).

Installation of different heating circuits...

- radiator heating circuit (high-temp. circuit)
- under floor heating circuit with 3-way mixing valve (low-temp. circuit)
- DHW production

... with the following flow conditions:

1. The water flow rate (output) of the radiator heating circuit is at least 30% greater than that of the under floor heating circuit.
2. The total flow rate of the two heating circuits is less than the maximum possible water flow rate of the Vitodens 200-W B2HA boiler (see page 30 for max. water flow rate).
The use of a low-loss header is strongly recommended if the maximum water flow rate in the application concerned exceeds the values shown on page 30, or if the system flow rates are unknown. The low-loss header is available as accessory part.

See following pages for additional installation examples with a low-loss header.

The 3-way mixing valve, built-in to achieve the low-temperature level of the under floor heating circuit, is controlled by an accessory kit for a heating circuit with mixing valve.

System Layout 5

Vitodens 200-W, B2HA with...

- DHW storage tank
- one heating circuit with mixing valve
- one heating circuit without mixing valve and low-loss header

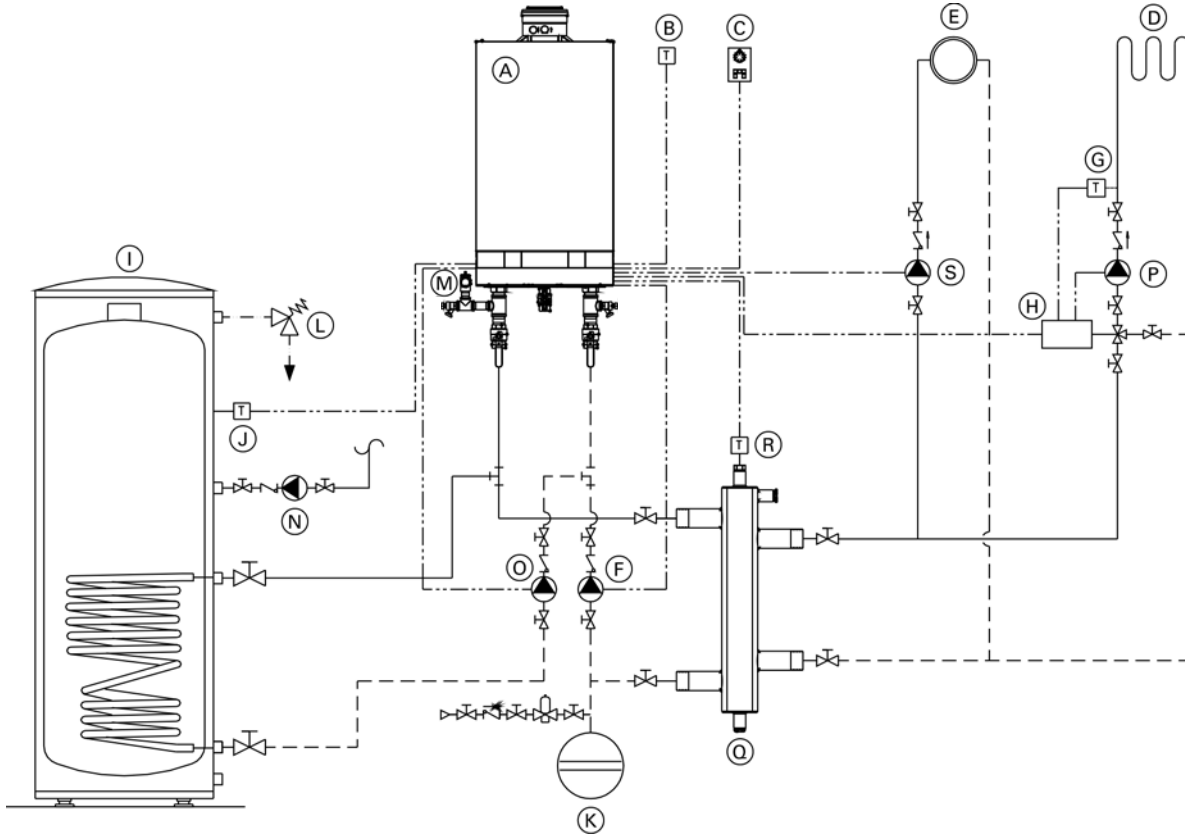

Legend

- (A) Vitodens 200-W B2HA boiler with Vitotronic 200, HO1B outdoor reset control
 - (B) Outdoor temperature sensor [1]
 - (C) Vitotrol remote (optional)
 - (D) Under floor heating circuit
 - (E) Radiator heating circuit
 - (F) Boiler circuit pump [20]
 - (G) Mixing valve temperature sensor [2]
 - (H) Kit for heating circuit with mixing valve
 - (I) Domestic hot water storage tank
 - (J) DHW tank temperature sensor [5]
 - (K) Expansion tank
 - (L) Temperature and pressure relief valve
 - (M) Pressure relief valve
 - (N) DHW recirculation pump [28/20] *
 - (O) DHW circulating pump [21]
 - (P) Heating circuit pump
 - (Q) Low-loss header
 - (R) Viessmann temperature sensor for low-loss header [2]
 - (S) Heating circuit pump [28/20] *
- * Function based on coding of address 53

Installation of different heating circuits...

- radiator heating circuit (high-temp. circuit)
- under floor heating circuit with 3-way mixing valve (low-temp. circuit)
- DHW production

... with the following flow conditions:

The total flow rate of the two heating circuits is greater than the maximum possible water flow rate of the Vitodens 200-W B2HA boiler (see page 30 for maximum water flow rate of boiler).

The use of a low-loss header is strongly recommended. The low-loss header is available as accessory part.

The 3-way mixing valve, built-in to achieve the low-temperature level of the under floor heating circuit, is controlled by an accessory kit for a heating circuit with mixing valve.

IMPORTANT

DHW circulating pump (O) must pump into the Vitodens 200-W B2HA boiler (as illustrated).

System Layout 6

Vitodens 200-W, B2HA with...

- DHW storage tank
- one heating circuit without a mixing valve
- two heating circuits with a mixing valve
- low-loss header

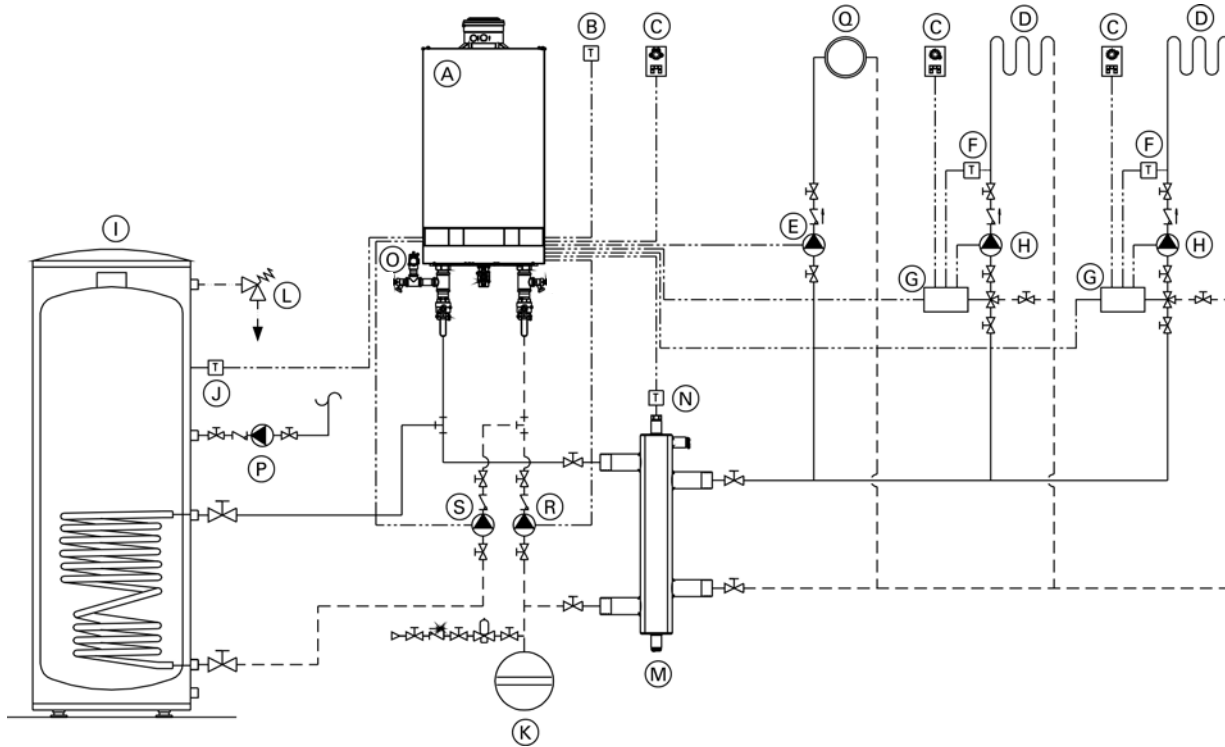

Legend

- (A) Vitodens 200-W B2HA boiler with Vitotronic 200, HO1B outdoor reset control
- (B) Outdoor temperature sensor [1]
- (C) Vitotrol remote (optional)
- (D) Under floor heating circuit
- (E) Heating circuit pump [28/20]*
- (F) Mixing valve temperature sensor [2]
- (G) Accessory kit for heating circuit with mixing valve
- (H) Heating circuit pumps
- (I) DHW storage tank
- (J) DHW tank temperature sensor [5]
- (K) Expansion tank
- (L) Temperature and pressure relief valve
- (M) Low-loss header
- (N) Viessmann temperature sensor for low-loss header [2]
- (O) Pressure relief valve
- (P) DHW recirculation pump [28/20]*
- (Q) Radiator heating circuit
- (R) Boiler pump [20]
- (S) DHW circulating pump [21]

* Function based on coding of address 53

Installation of different heating circuits...

- two heating circuits with 3-way mixing valve (low-temp. circuit)
- DHW production

... with the following flow conditions:

The total flow rate of the two heating circuits is greater than the maximum possible water flow rate of the Vitodens 200-W B2HA boiler (see page 30 for maximum water flow rate of boiler).

The use of a low-loss header is strongly recommended.

The low-loss header is available as accessory part.

The 3-way mixing valve, built-in to achieve the low-temperature level of the under floor heating circuit, is controlled by an accessory kit for a heating circuit with a mixing valve.

IMPORTANT

DHW circulating pump (S) must pump into the Vitodens 200-W B2HA boiler (as illustrated).

System Layout 7

Vitodens 200-W, B2HA with...

- direct-connected heating circuit
- one heating circuit with system separation

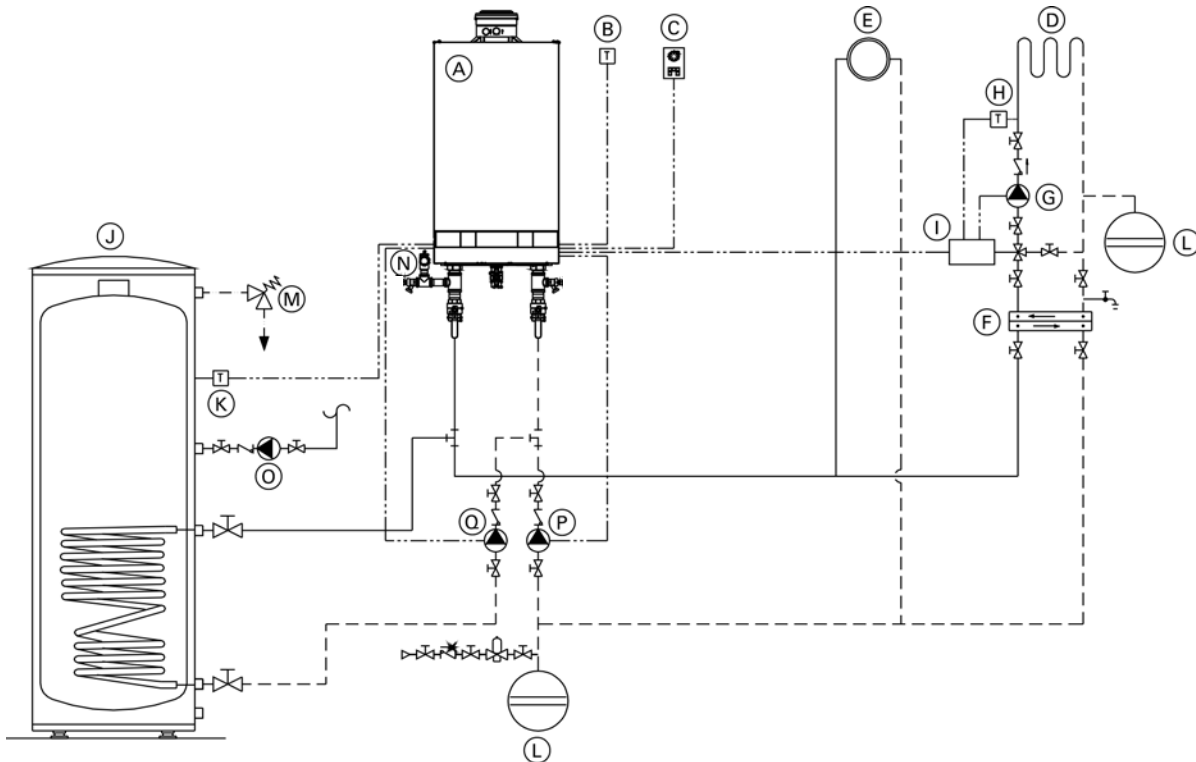

Legend

- (A) Vitodens 200-W B2HA boiler with Vitotronic 200, HO1B outdoor reset control
- (B) Outdoor temperature sensor [1]
- (C) Vitotrol remote (optional)
- (D) Under floor heating circuit
- (E) Radiator heating circuit
- (F) Plate heat exchanger for system separation
- (G) Heating circuit pump
- (H) Mixing valve temperature sensor [2]
- (I) Accessory kit for heating circuit with mixing valve
- (J) DHW storage tank
- (K) DHW tank temperature sensor [5]
- (L) Expansion tanks
- (M) Temperature and pressure relief valve
- (N) Pressure relief valve
- (O) DHW recirculation pump [28/20] *
- (P) Boiler pump [20]
- (Q) DHW circulating pump [21]

* Function based on coding of address 53

IMPORTANT

DHW circulating pump (Q) must pump into the Vitodens 200-W B2HA boiler (as illustrated).

Installation of different heating circuits...

- radiator heating circuit (high-temp. circuit)
- under floor heating circuit with 3-way mixing valve (low-temp. circuit)
- DHW production

... with the following flow conditions:

The total flow rate of the two heating circuits is less than the maximum possible water flow rate of the Vitodens 200-W B2HA boiler (see page 30 for maximum water flow rate of boiler).

The use of a low-loss header is strongly recommended if the maximum water flow rate in the application concerned exceeds the max. boiler flow rate, or if the system flow rates are unknown. The low-loss header is available as accessory part.

The 3-way mixing valve, built-in to achieve the low-temperature level of the under floor heating circuit, is controlled by an accessory kit for a heating circuit with mixing valve (I). The boiler pump [20] supplies the radiator heating circuit and the plate heat exchanger for system separation.

IMPORTANT

The pressure drop (secondary circuit) of the plate heat exchanger (F) must be less/equal to the pressure drop of the 3-way mixing valve. This must be taken into account when sizing the plate heat exchanger.

System Layout 8

Vitodens 200-W, B2HA with...

- DHW storage tank
- low-loss header
- multiple heating circuits with mixing valves
- one heating circuit without mixing valve

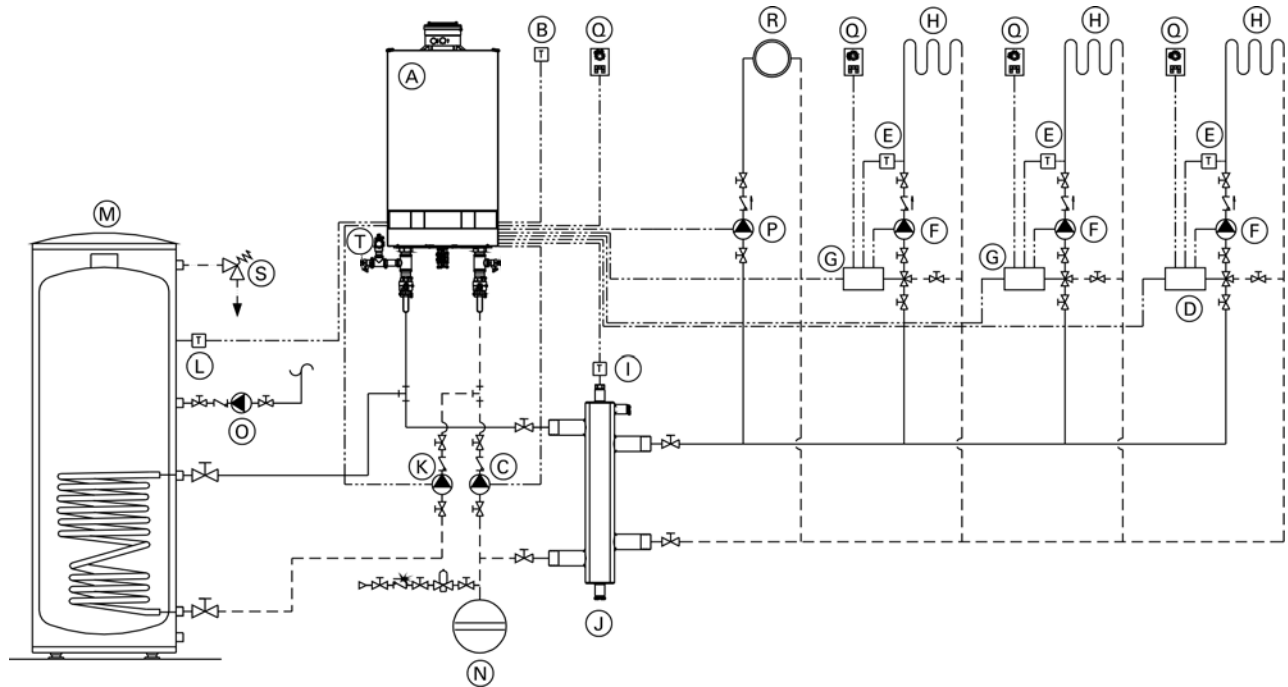

When designing a system as illustrated above, please contact your local Viessmann Sales Representative for assistance.

Legend

- (A) Vitodens 200-W B2HA boiler with Vitotronic 200, HO1B outdoor reset control
- (B) Outdoor temperature [1]
- (C) Boiler pump [20]
- (D) Vitotronic 200-H, HK1B *1
- (E) Mixing valve temperature sensor [2]
- (F) Heating circuit pumps
- (G) Accessory kit for heating circuit with mixing valve
- (H) Heating circuits with mixing valves
- (I) Viessmann temperature sensor for low-loss header [2]
- (J) Low-loss header
- (K) DHW circulating pump [21]
- (L) DHW tank temperature sensor [5]
- (M) DHW storage tank
- (N) Expansion tank
- (O) DHW recirculation pump [28]
- (P) Heating circuit pump [28/20]*
- (Q) Vitotrol remote (optional)
- (R) Radiator heating circuit
- (S) Temperature and pressure relief valve
- (T) Pressure relief valve

* Function based on coding of address 53

*1 Contact your local Sales Representative for details.

Vitotronic 200-H, HK1B mixing valve control with LON communication module can be used instead of the accessory kit and Vitocontrol.

IMPORTANT

Please note location of expansion tank (N).

IMPORTANT

Pumps (C) and (K) must pump into the Vitodens 200-W B2HA boiler (as illustrated).

System Layout 9

Vitodens 200-W, B2HA/B2HB with...

- DHW storage tank
- low-loss header
- three zone circuits

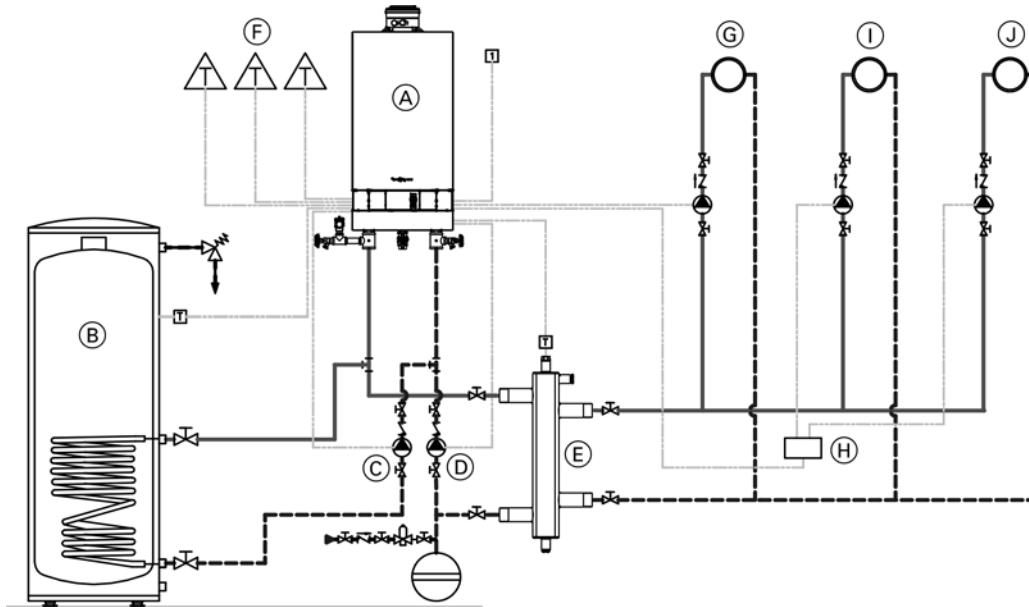

Legend

- (A) Vitodens 200-W boilers
- (B) DHW storage tank
- (C) DHW pump [output 21]
- (D) Boiler pump [output 20]
- (E) Low-loss header
- (F) Thermostat zone circuits 1, 2, 3 (dry contact)
- (G) Zone circuit 1 [output 157]
- (H) AM1 extension module (accessory)
- (I) Zone circuit 2 [output A1 - AM1 extension module]
- (J) Zone circuit 3 [output A2 - AM1 extension module]

Installation of different heating circuits...

- DHW production
- 3 zone circuits

... with the following flow conditions:

The total flow rate of the two heating circuits is greater than the maximum possible water flow rate of the Vitodens 200-W B2HA/B boiler.

The use of a low-loss header is strongly recommended. The low-loss header is available as accessory part.

A 3-way mixing valve, built-in to achieve the low-temperature level of the under floor heating circuit, is controlled by an accessory kit for a heating circuit with a mixing valve.

IMPORTANT

System separation is required of underfloor heating systems employing non-oxygen diffusion barrier tubing. All components on the secondary side of the heat exchanger must be made of corrosion-resistant materials.

System Layout 10

Multiple (up to eight) Vitodens 200-W, models B2HA 80 to 100, 285 to 352 with...

- multiple heating circuits with mixing valves
- low-loss header

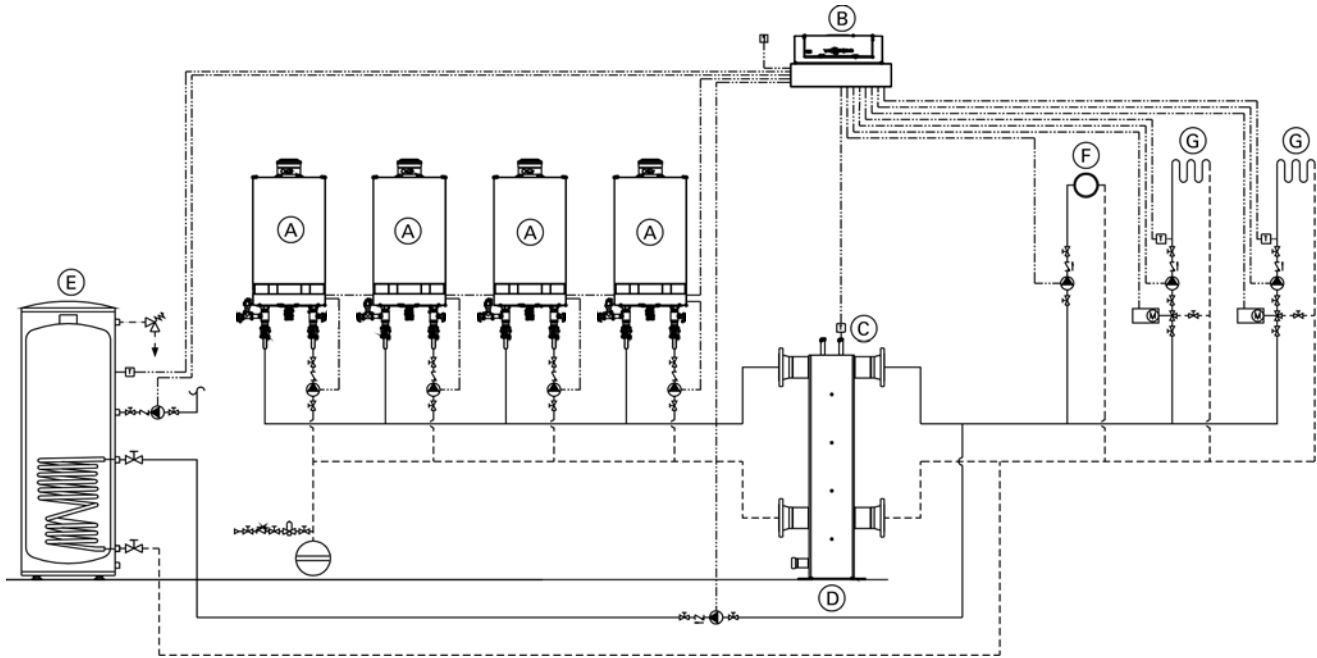

Legend

- (A) Vitodens boiler
- (B) Vitotronic 300K
- (C) Low-loss header/common supply temperature sensor
- (D) Low-loss header
- (E) DHW storage tank
- (F) High temperature heating circuit
- (G) Low temperature heating circuit

When designing a multiple Vitodens system as shown above, please reference applicable multiple Vitodens technical documentation, and contact your local Viessmann Sales Representative for further assistance.

This installation example depicts a possible piping layout for multiple Vitodens 200-W, B2HA boilers equipped with Viessmann System Technology. Please note that this example is based on a simplified conceptual drawing only! Piping and necessary componentry must be field verified. A low water cut-off (LWCO) must be installed where required by local codes.

Proper installation and functionality in the field is the responsibility of the heating contractor.

WARNING

If a DHW storage tank other than a Viessmann Vitocell 100 or 300 tank is used, the installer must verify proper operation of the Viessmann DHW tank temperature sensor with the original manufacturer of the tank. Viessmann strongly recommends the installation of a temperature tempering valve in the DHW supply line.

Alternative DHW Connection

The following piping diagram reflects an alternative connection for the DHW tank only and applies to system layouts 2, 5, 6 and 8. The boiler control pump logic function must be programmed in the Service Instructions.

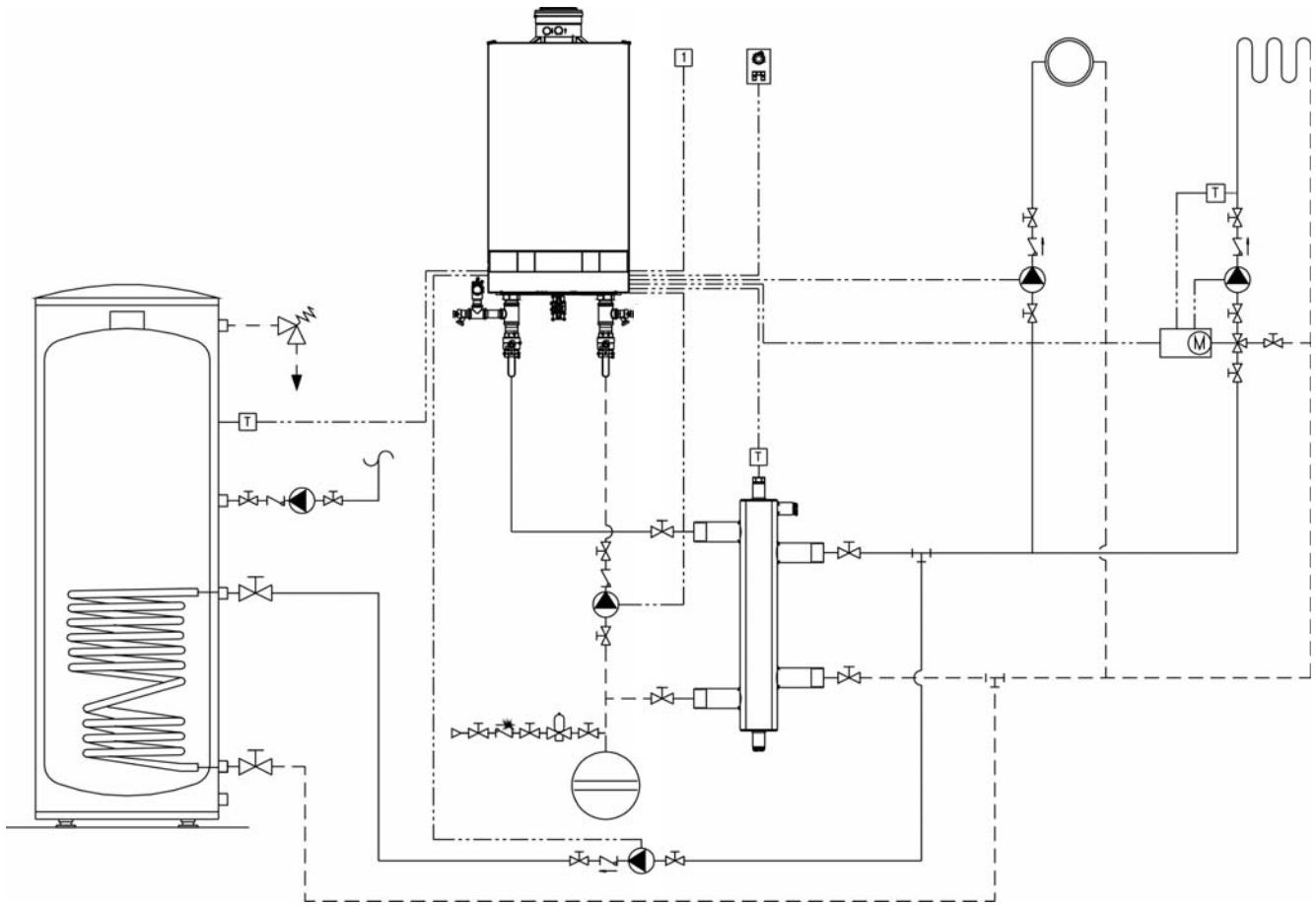

***Note:** When using a low loss header in the system, the DHW connections can be made downstream of the low loss header. See Vitodens 200-W B2HA Service Instructions for applicable system coding information (see coding level 2):

00: ...

A2: ...

5b: ...

Boiler in Heating/Cooling

Boiler in heating/cooling application

The boiler, when used in connection with a refrigeration system, must be installed ensuring the chilled medium is piped in parallel to the boiler with appropriate valves to prevent the chilled medium from entering the boiler. See illustration on the left.

The boiler piping system of a hot water heating boiler connected to heating coils located in air handling units where they may be exposed to refrigerated air circulation must be equipped with flow control valves or other automatic means to prevent gravity circulation of the boiler water during the cooling cycle.

Check installation instructions of the chiller manufacturer carefully for additional requirements.

Cooling season starts:

Close valve "v1" and open valve "v2".

Heating season starts:

Close valve "v2" and open valve "v1".

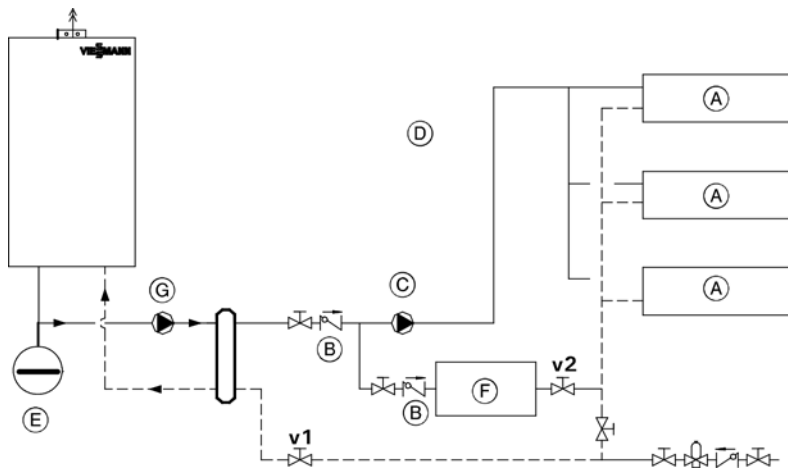

IMPORTANT

Viessmann strongly suggests that the valves illustrated be labelled "v1" and "v2".

IMPORTANT

In the illustration, the circulating pump must be operated from a separate on/off switch, not from the pump aquastat on the boiler control.

Legend

- (A) Heating/Cooling unit
- (B) Spring-loaded flow check valve
- (C) Circulation pump
- (D) Safety header with automatic air vent and pressure relief valve
- (E) Expansion tank
- (F) Water chiller
- (G) Boiler circuit pump (field supplied)

Boiler with Low Water Cut-off

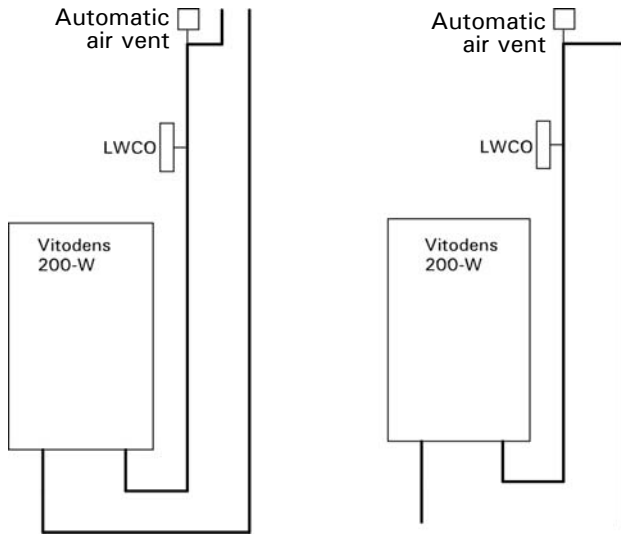

Boiler with low water cut-off (remote-mounted, field supplied)

A low water cut-off may be required by local codes. Do not install an isolation valve between boiler and low water cut-off.



Follow the installation instructions of the low water cut-off from the manufacturer.

For low water cut-off wiring information specific to your application, refer to applicable wiring diagram (see page 47).

Venting Connection



CAUTION

Under certain climatic conditions some building materials may be affected by flue products expelled in close proximity to unprotected surfaces. Sealing or shielding of the exposed surfaces with a corrosion resistant material (e.g. aluminum sheeting) may be required to prevent staining or deterioration. The protective material should be attached and sealed (if necessary) to the building before attaching the vent termination. It is strongly recommended to install the vent termination on the leeward side of the building.



Vitodens 200-W, B2HA Installation Instructions Venting System

Electrical Connections

Power supply connection of accessories

The power supply connection of accessories can be made directly at the control. The connection is activated and deactivated with the system on/off switch.

The Vitotronic 200-H, HK1B mixing valve control, the mixing valve accessory kit and the Solartrol control require a separate 120 VAC power supply from the wall receptacle.

Closing the control unit casing and inserting (continued) Insert programming unit (packed separately) into the control unit support.

Note: The programming unit can also be used in a wall mounting base (accessory) near the boiler

Cabling required for:

- outdoor temperature sensor
- Vitotronic 200-H, HK1B mixing valve control
- accessory kit for heating circuit with mixing valve
- remote switching of operating mode
- remote disable
- alarm output
- wall-mount base
- circulating pump

IMPORTANT

It is essential to route cables as illustrated to ensure freedom of movement of control unit.

IMPORTANT

When running and securing connecting cables on site, ensure that the maximum permissible temperatures of the cables are not exceeded.

IMPORTANT

Cables in the vicinity of the control unit must not be secured to the control unit bracket.

Connection of accessories



For details regarding other installation steps required, please reference the Installation Instructions supplied with the respective accessory part.

Note: Only one accessory part or one switch contact can be connected to the contacts of a plug at a time.

Overview of Electrical Connections, Models B2HA 80 to 100, 285 to 352

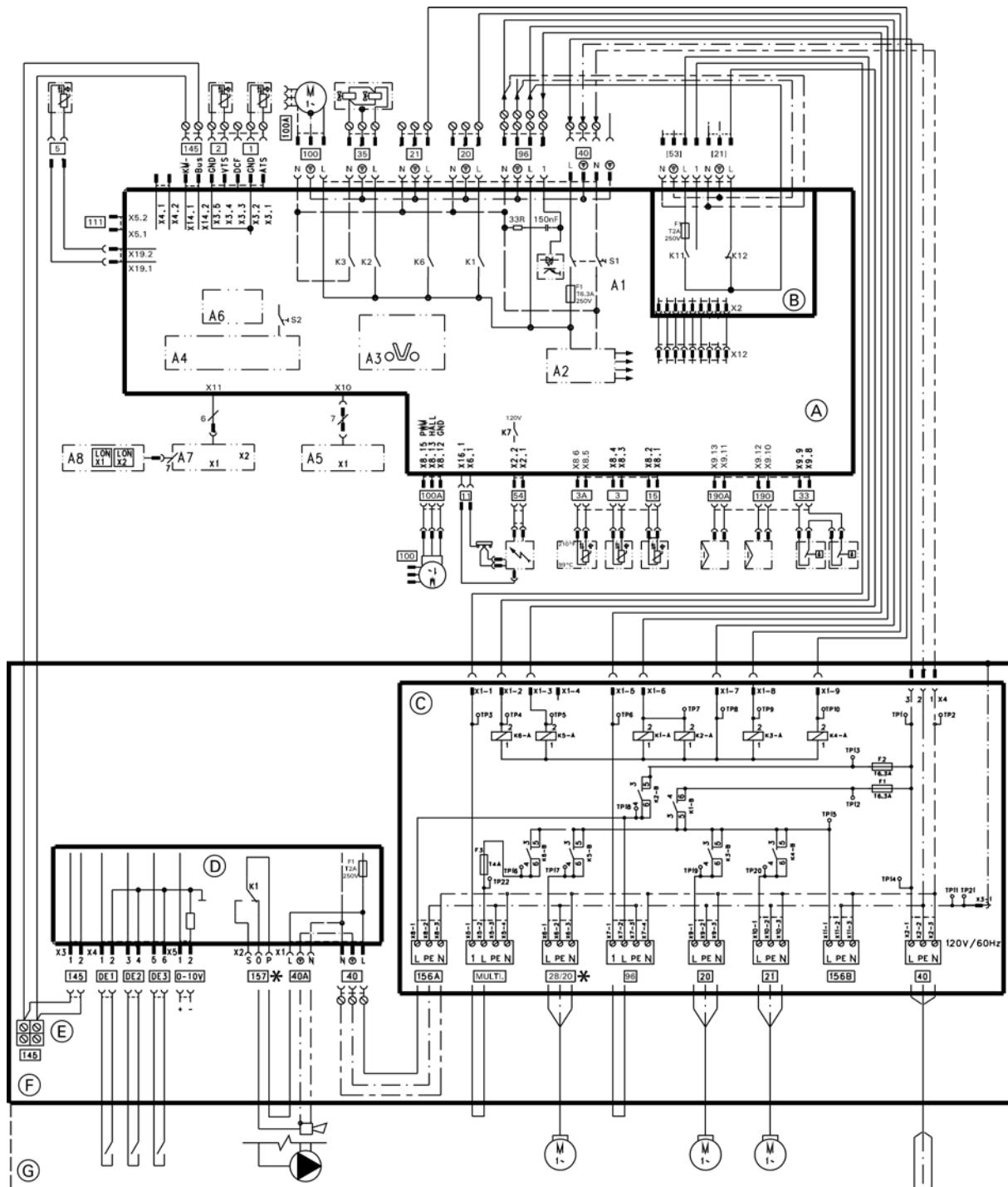

⚠ WARNING
DISCONNECT POWER BEFORE SERVICING BOILER.

If any of the original wires as supplied with the appliance must be replaced, it must be replaced with the exact equivalent.

⚠ CAUTION
 Label all wires prior to disconnection when servicing controls. Wiring errors can cause improper and dangerous operation. Verify proper operation after servicing.

* Only one function/accessory may be assigned to each connection.

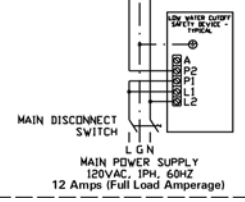

Overview of Electrical Connections, Models B2HA 80 to 100, 285 to 352 *(continued)*

Legend

1	Outdoor Temperature Sensor
2	Supply Temperature Sensor/Low Loss Header
3	Boiler Temperature Sensor/High Limit Sensor
3A	Boiler Temperature Sensor/High Limit Sensor
5	DHW Temperature Sensor
11	Ionization Electrode
15	Flue Gas temperature Sensor
20	Boiler Pump
21	DHW Pump
[21]	Pump Output Connection
28/20	Programmable Pump Output / zone circuit pump output*
33	Flow Switch (X2 FOR MODELS 80 to100, 285 to 352)
35	Gas Valve (X2 FOR MODELS 80 to100, 285 to 352)
40	Power Supply
40A	Accessory Power Output
[53]	Powered Accessory Connection
54	Ignition Transformer
96	Powered Accessory Connection
100	Fan Motor
100A	Fan Motor Control
111	Not Used
145	KM-BUS
Multi	Powered Accessory Connection
156A	Switched Output F2
156B	Switched Output F1
DE1	Digital Input 1 (Dry Contact)
DE2	Digital Input 2 (Dry Contact)
DE3	Digital Input 3 (Dry Contact)
0-10V	0-10VDC Input
157	Fault Alarm/DHW Recirc. Pump / zone circuit pump output*
190	Gas Modulation Coil
190A	Gas Modulation Coil (for 80 to100, 285 to 352)

* See wiring diagram

- Ⓐ Boiler Control
- Ⓑ External Accessory Connection Board
- Ⓒ Pump Connection Interface
- Ⓓ Extension Module EA1
- Ⓔ KM-BUS for External Devices
- Ⓕ Electrical Junction Box
- Ⓖ Field Wiring Connections
- A1 Main Board
- A2 Internal Power Supply Unit
- A3 Optolink
- A4 Burner Control Unit
- A5 Programming Unit
- A6 Coding Card
- A7 Connection Adaptor
- A8 LON Communication Module
- S1 ON/OFF Switch
- S2 Reset Button
- X.. Electrical Interface

IMPORTANT

Electrical installations must comply with the latest edition of:

- In the U.S.A., the National Electrical Code (NEC), ANSI/NFPA 70 and any other state, local codes and/or regulations.
- In Canada, the Canadian Electrical Code (CEC), CSA C22.1 Part 1 and any other province, territory, local codes and/or regulations.

Accessing the X3 Plug

1. Remove the control unit cover (see page 23).
2. Remove the X3 plug from the control board. Install the required sensors as per installation instructions.
3. Reinstall the control cover.

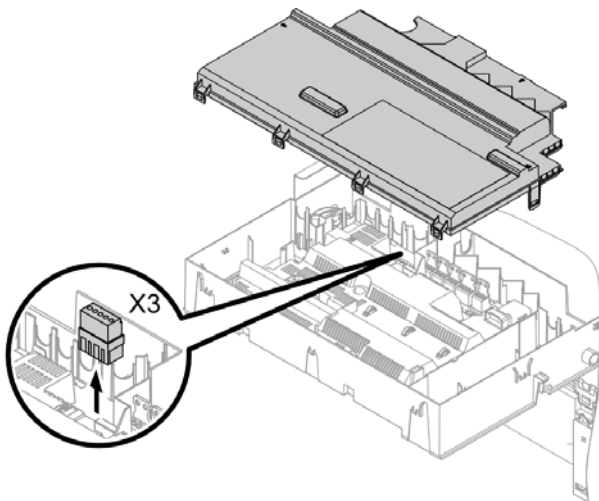

Connecting the Low-loss Header Sensor

1. Connect the low-loss header sensor (if used) to terminals X3.4/X3.5 on the boiler control board.

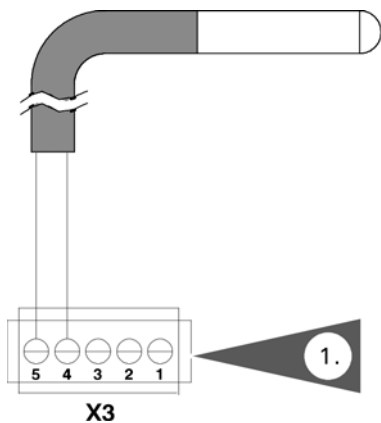

Connecting the Outdoor Temperature Sensor

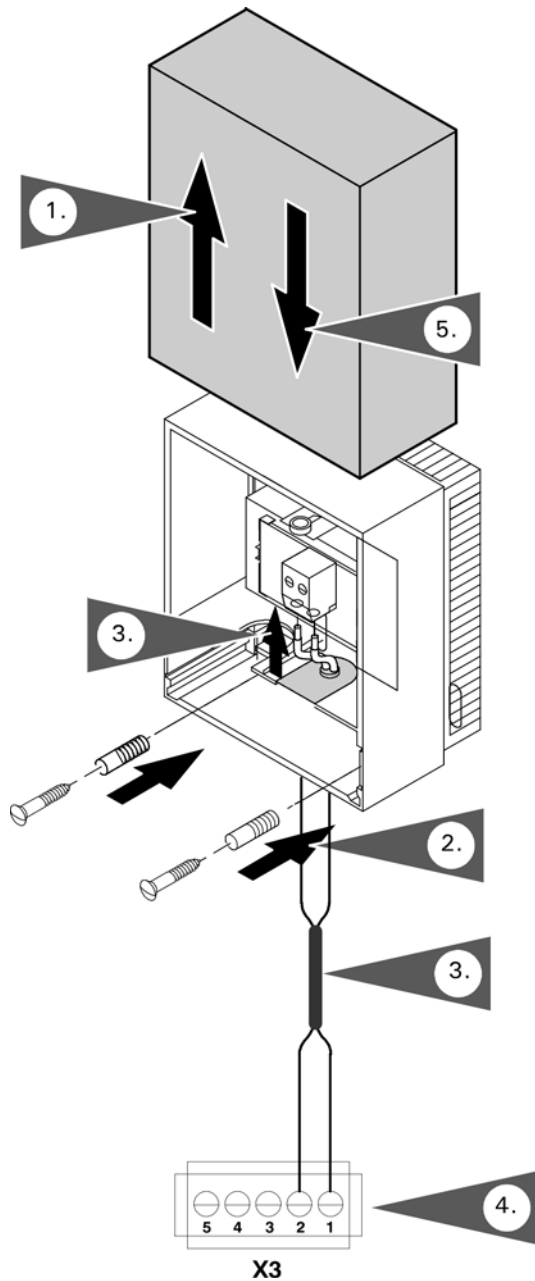

1. Remove cover of outdoor temperature sensor.
2. Mount wall-mount base (cable entry must point downward).

IMPORTANT

The outdoor temperature sensor should be mounted 6.6 to 8.2 ft. (2 to 2.5 m) above ground level on the north or northwest wall of the building. In case of a multi-storey building, mount outdoor temperature sensor in the upper half of the second floor.

Ensure that sensor is not located above windows, doors and air vents, or immediately underneath a balcony or gutter.

The outdoor temperature sensor must not be covered by plaster. If mounting on an unplastered wall, make allowances for thickness of plaster or remove sensor before plastering wall.

3. Route cable from the boiler control board to the outdoor sensor. Connect cable to sensor terminals (wires are interchangeable).
Cable specifications:
2-wire cable, max. cable length 95 ft. (35 m) with a wire size of min. AWG 16 copper.
4. Connect the outdoor temperature sensor to terminals X 3.1/X3.2 on the boiler control board (wires are interchangeable).
5. Place cover on base and snap into place.

IMPORTANT

Cable to the outdoor sensor must not be laid near line voltage wiring (120/240V).

External 0-10 Volt Signal Connection

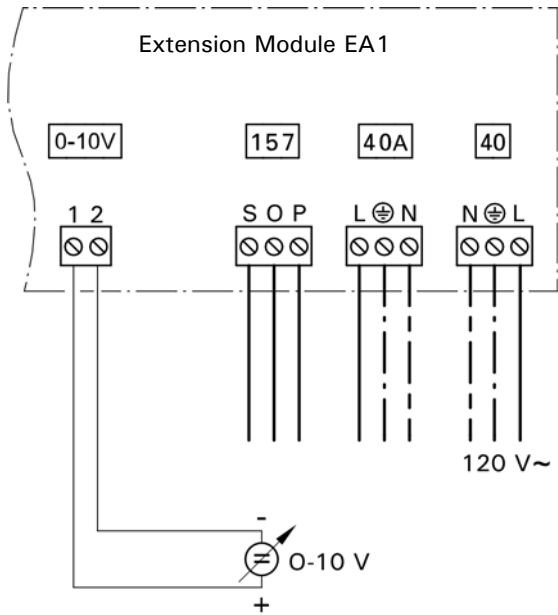

1. Connect the external 0-10V signal to plug 0-10V located in the extension module EA1.
2. Ensure correct polarity.
3. See chart for maximum possible boiler water temperature and required signal.

Example: Voltage to temperature setpoint
 8VDC = 176°F (80°C)

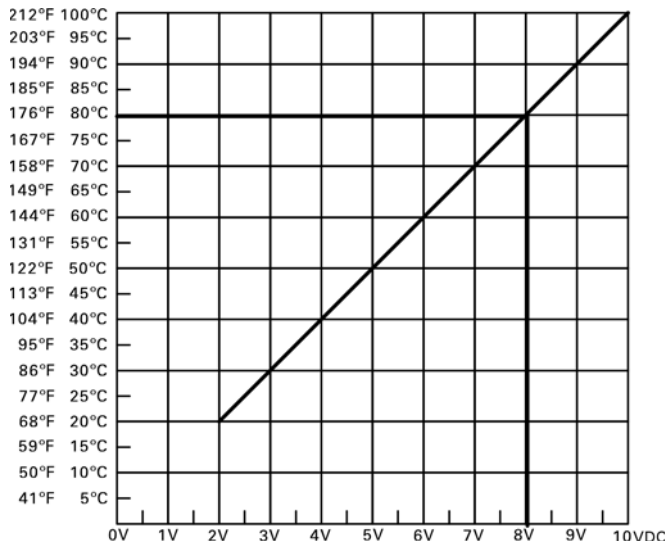

Connecting a 24VAC Thermostat

1. Connect normally open dry contact of the switching relay ('T-T' contact) to terminal DE1, DE2 or DE3 of the EA1 module located in the boiler electrical junction box.
2. Connect switching relay to thermostat and power supply as per manufacturers instructions.

When the thermostat contact is closed, burner operation is load-dependent. The supply water is heated to the value set in the coding address "9b" in the "General" group of the boiler.

The supply water temperature is limited by this set value and the electronic supply temperature maximum limit.

Codes

Extension EA1 Set "3A", "3B" or "3C" in the "General" group to 2.

Note: 'Live' contacts lead to short circuits or phase failure. The external connection must be potential-free.

Note: When only using a thermostat (field supplied) for room temperature control, the boiler standard and reduced room temperature set points may be set to 37°F (3°C) to reduce boiler cycling.

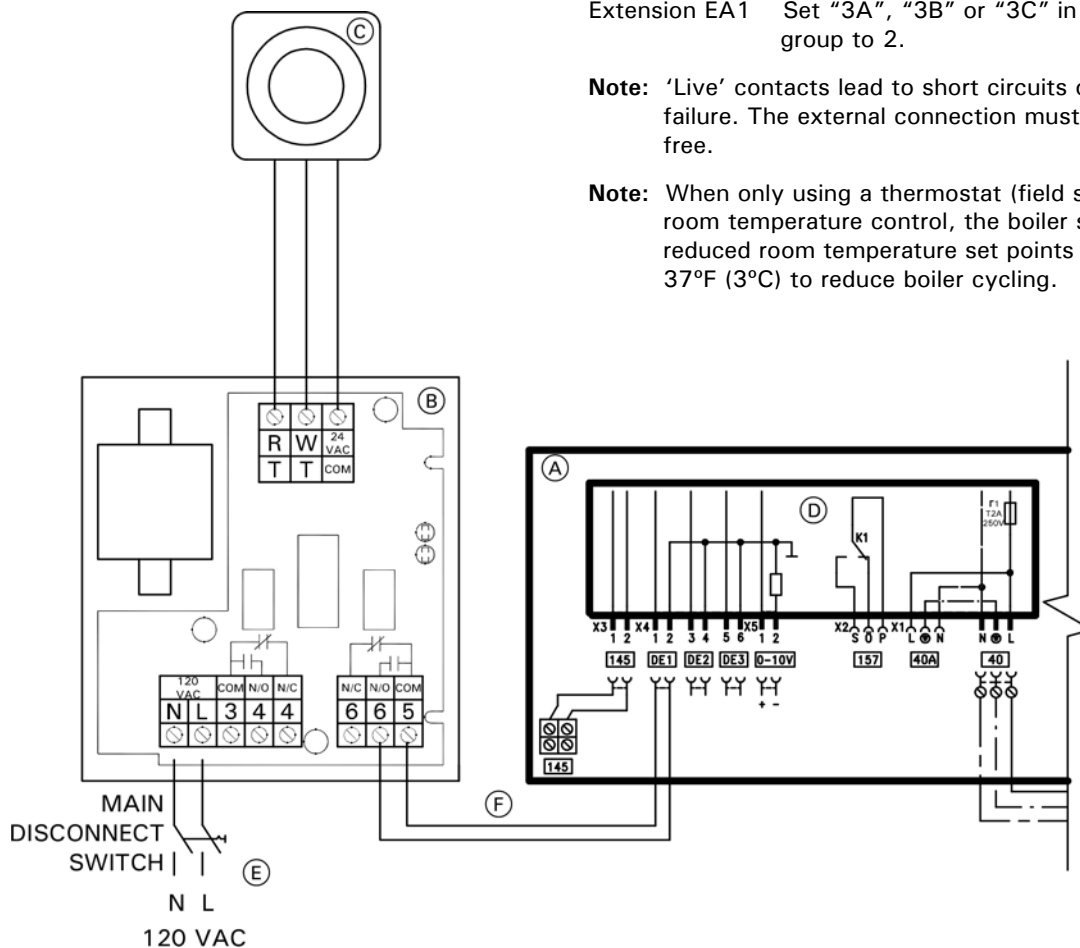

Legend

- (A) Boiler electrical junction box
- (B) Switch relay (ie Taco SR501, Honeywell RA889A-1001, field supplied)
- (C) 24VAC room thermostat (field supplied)
- (D) Internal EA1 module
- (E) 120VAC power supply for switching relay (refer to manufacturers instructions)
- (F) Dry contact connection from switching relay (to boiler 'T-T')

Thermostat Connection

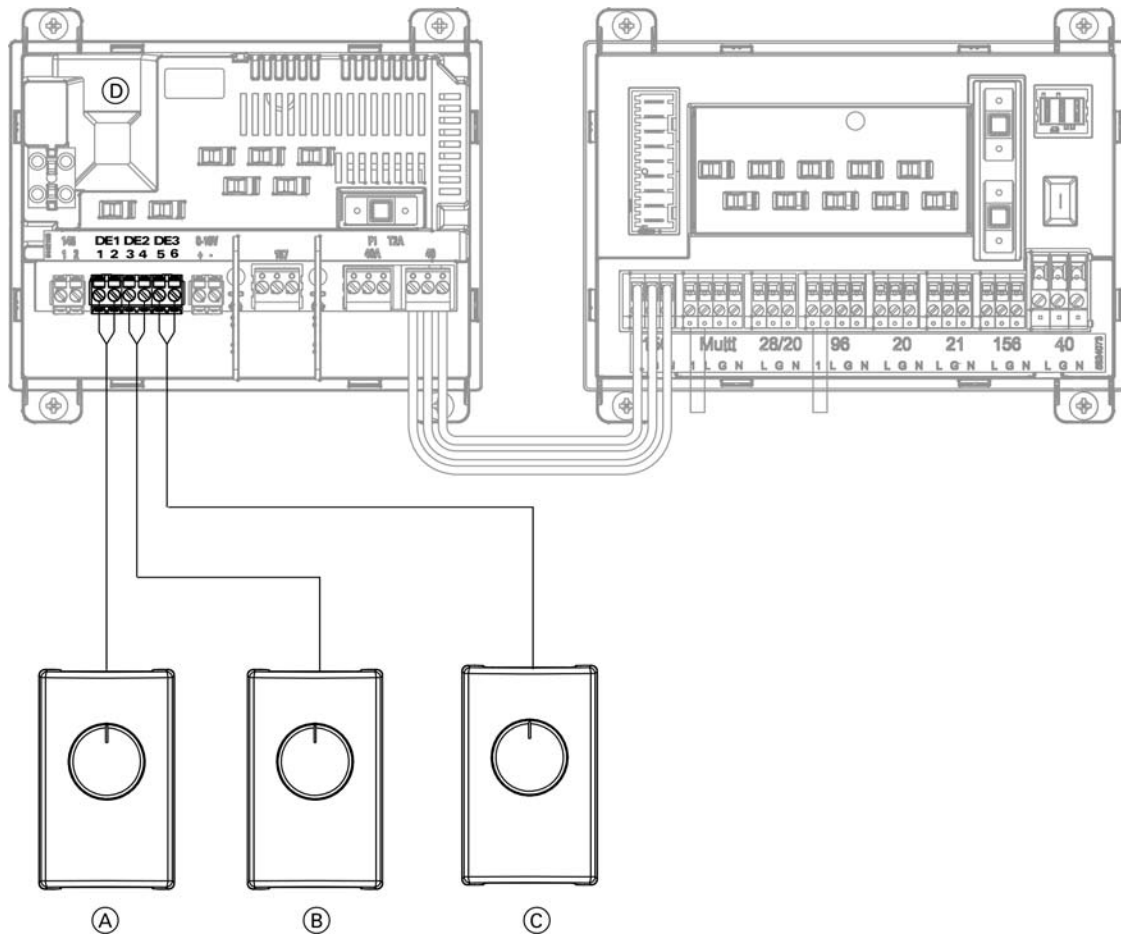

Legend

- (A) Room thermostat (dry contact) zone circuit 1
- (B) Room thermostat (dry contact) zone circuit 2
- (C) Room thermostat (dry contact) zone circuit 3
- (D) EA1 module (integrated into the boiler)



Refer to the boiler Installation Instructions for locating and accessing the integrated EA1 module.

Connection to boiler

Pump output assignment is done using the start-up wizard.

A maximum of 2 zone circuit pumps can be connected to the boiler additional pumps will require the use of an AM1 extension module.



Refer to the AM1 extension module Installation Instructions for additional details.

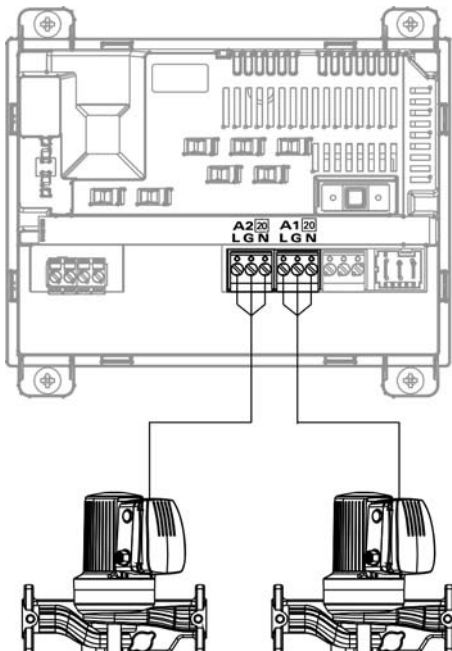
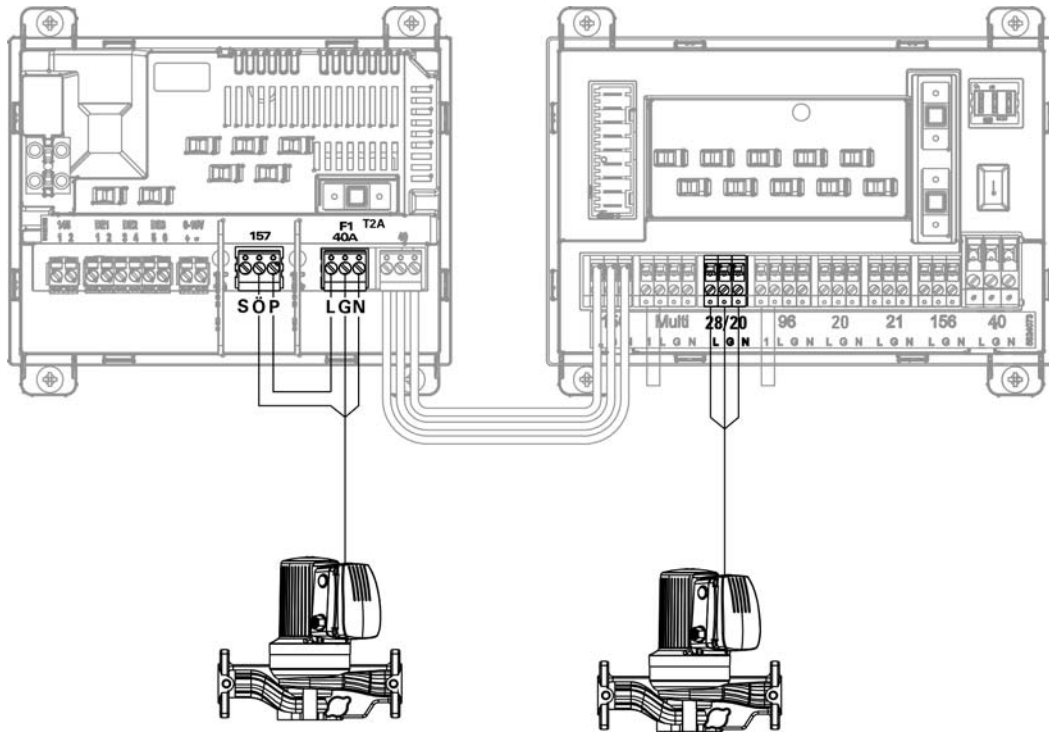

Connection at AM1 (accessory)

Pump output assignment is done using the start-up wizard.



Refer to the boiler Service Instructions for start-up instructions.

LON Module

Installing the LON module to the boiler control board

1. Remove the control cover (see page 23).
2. Insert the LON module into the boiler control board.
3. Connect the LON connector cable to the LON module.

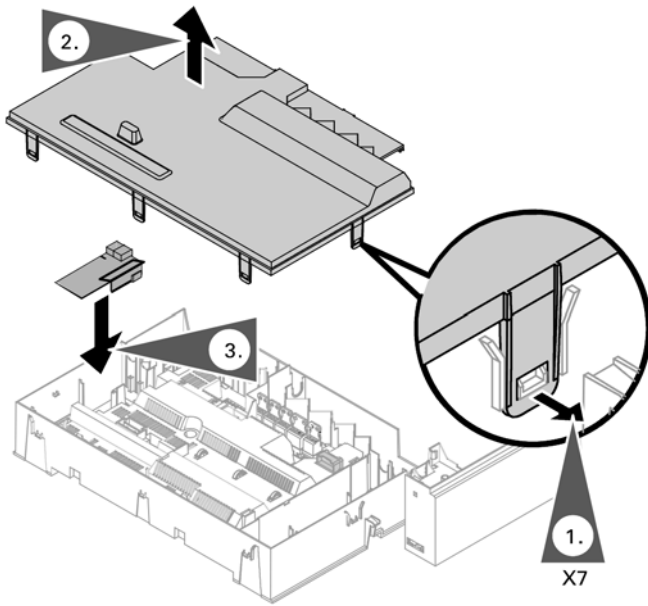

Connecting the LON module cable



See the Vitotronic 200-H
HK1B Installation Instructions.

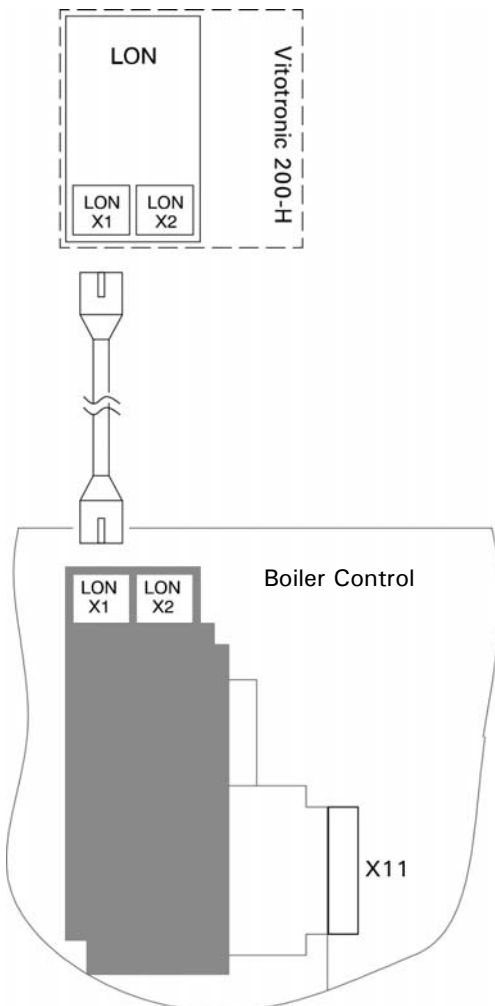

Accessory Kit

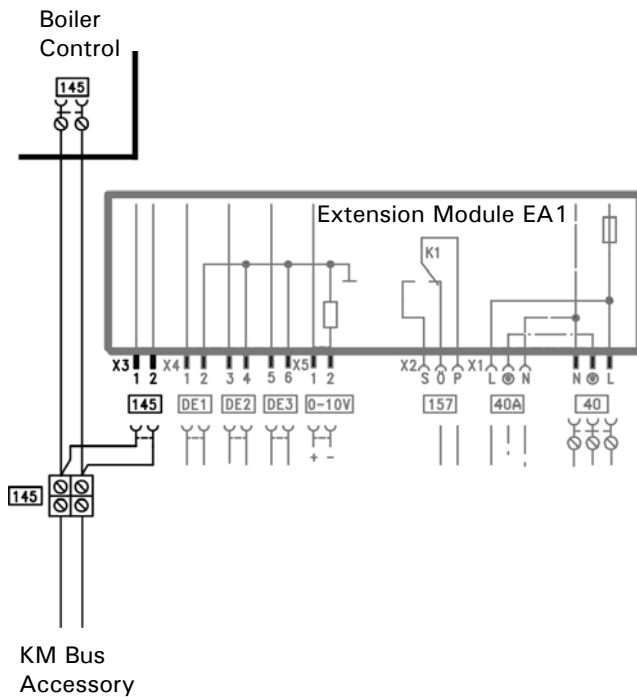

Accessory kit connections for heating circuit with mixing valve

The mixing valve controller kit can only be used with wall-mounted gas-fired hot water heating boilers and a weather-responsive control; it can be used as an alternative for a Vitotronic control.



For details on coding and connection to the control, refer to the Vitodens 200-W B2HA Service Instructions.



For details on installation, refer to the accessory kit Installation Instructions.

Closing the Control Unit

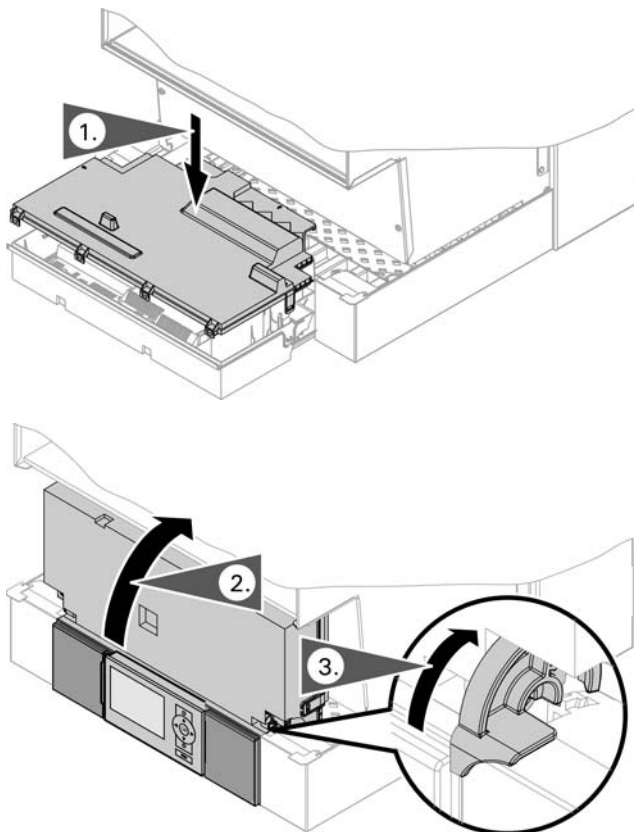

Closing the control cover

1. Install the cover onto the control board.
2. Flip the control board back into position.
3. Secure the locking tabs as shown.

Closing the External Accessory Connection Box

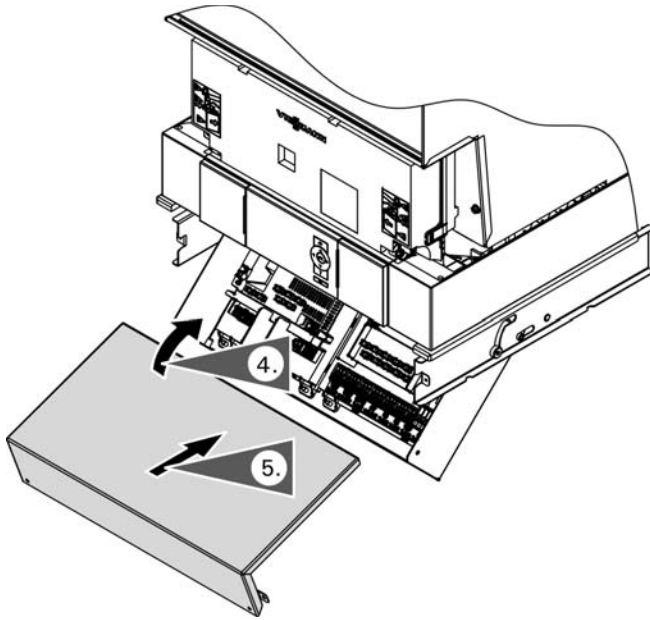

4. Tilt the top of the external accessory connection box cover forward.
5. Drop down over the locating pins and set the cover in place.

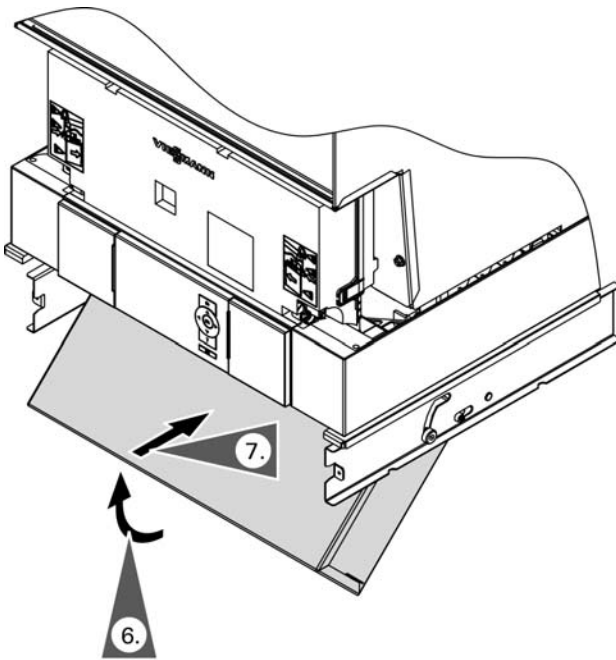

6. Swing the external accessory connection box up.
7. Push the external accessory connection box in until the holding screw is in place.

Closing the External Accessory Connection Box *(continued)*

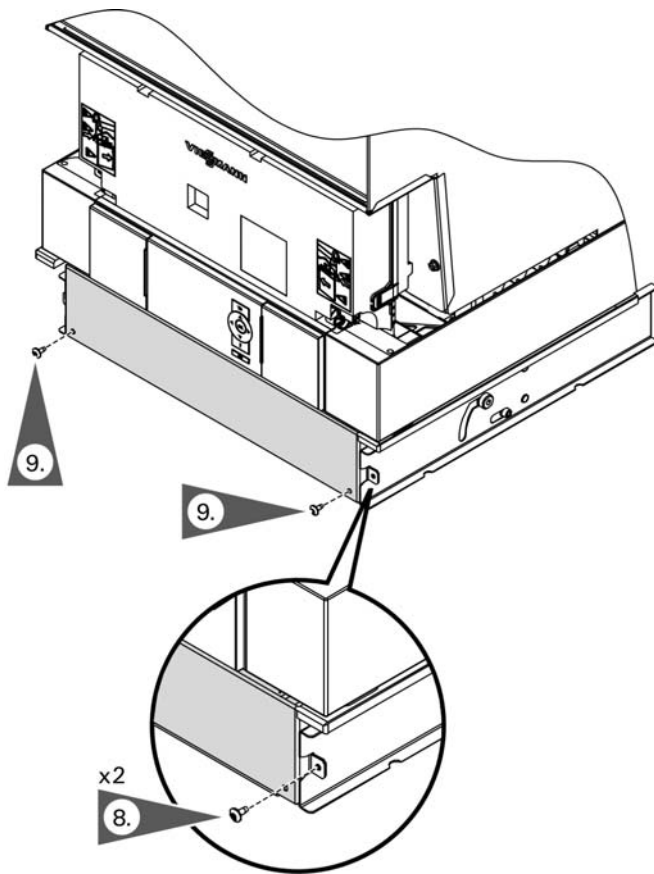

8. Tighten the external accessory connection box retaining screw.
9. Install the external accessory connection box cover screws.

Reinstalling the Front Enclosure Panel

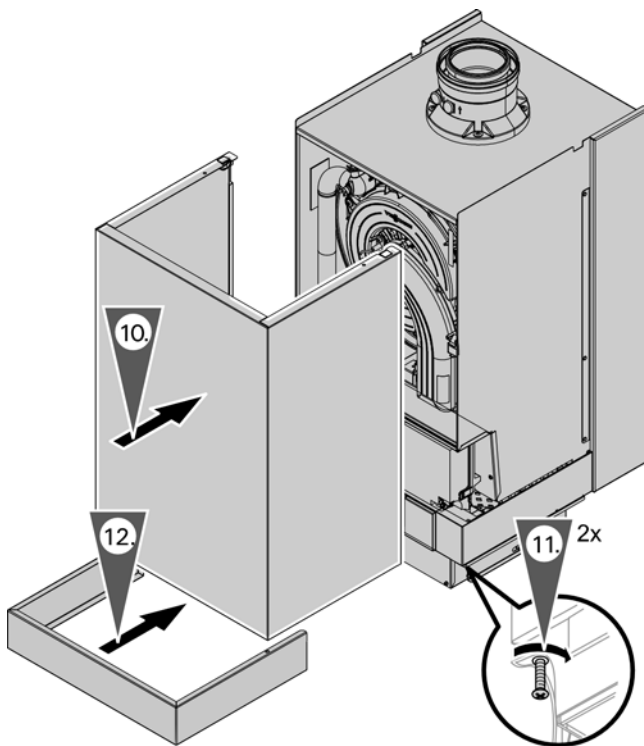

10. Set front enclosure panel on the guide rails and push in place.
11. Tighten screws at the bottom.
12. Insert the external accessories connection box cover in place.

Note: Ensure the locking screws are fitted before operating.

Instructing the system user

The system installer should hand the operating instructions to the system user and instruct the user in operating the system.

IMPORTANT

Read and follow, where applicable, the safety instructions of all labels and stickers attached to boiler surfaces. Do not remove any of these instructions. Contact Viessmann if any replacement labels are required.

Installation Fittings

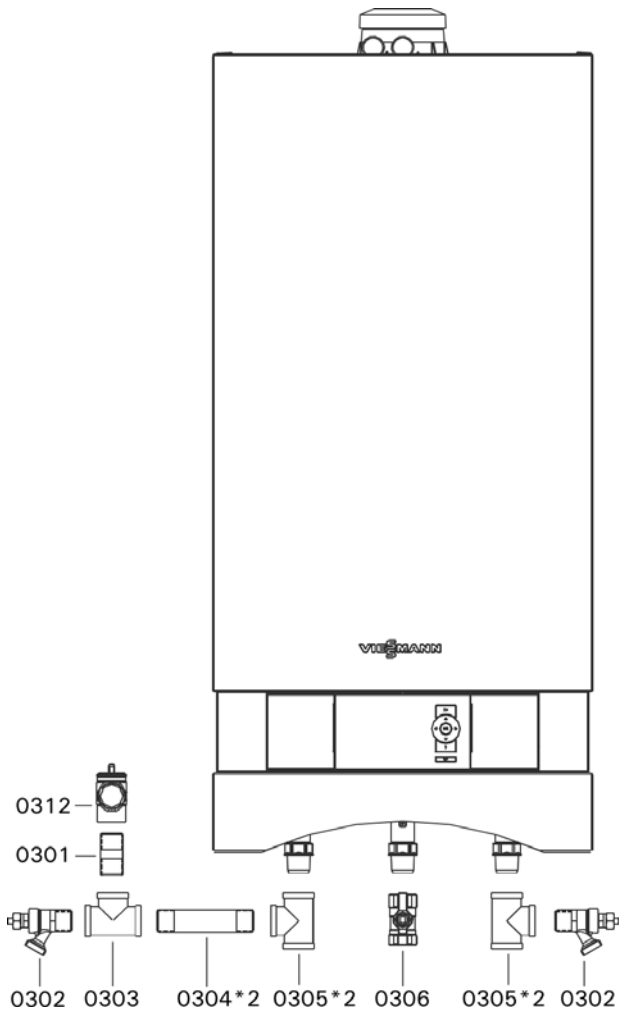

Parts

- 0301 Nipple ¼ in. x 1½ in.
- 0302 Sediment faucet ¾ in.
- 0303 Tee, ¾ in.
- 0304 Nipple ¾ in. x 3½ in.
- 0305 Reducing tee 1½ in. x 1½ in. x ¾ in.
- 0306 Gas ball valve 1 in.
- 0312 Pressure relief valve, 30 psig

Other Parts (not illustrated)

- 0309 Accessory pack (metal stud mount kit)
- 0311 Outdoor temperature sensor
- 0320 Technical literature set
- 0325 Parts List, Installation Fittings
- 0350 Temperature gauge 2 in. 30-250° F *1
- 0351 Temperature sensor (immersion)
for DHW production NTC
- 0352 Temperature sensor (immersion)
for low-loss header NTC (if low-loss header installed)

*1 Install anywhere in supply piping near boiler

*2 Discard when using multi-boiler distribution manifold

Technical Data

Boiler Model No. B2HA		80, 285	88, 311 *A	100, 352 *A
CSA input Natural Gas (NG)	MBH	71-285	71-311	71-352
	(kW)	(21-83)	(21-91)	(21-103)
CSA input Liquid Propane Gas (LPG)	MBH	104-285	104-311	104-311
	(kW)	(30-83)	(30-91)	(30-91)
CSA output NG	MBH	*1 65-260	*5 67-294	*5 67-333
	(kW)	(19-76)	(20-86)	(20-98)
CSA output LPG	MBH	*1 95-260	*5 98-294	*5 98-333
	(kW)	(28-76)	(29-86)	(29-98)
DOE/AHRI Gross output	MBH	--	292	329
	(kW)	--	(85)	(96)
Net AHRI Rating *4	MBH	226	254	286
	(kW)	(66.2)	(74)	(84)
Heat exchanger surface area	ft. ²	28.88	28.88	28.88
	(m ²)	(2.68)	(2.68)	(2.68)
Min. gas supply pressure				
Natural gas	"w.c.	4	4	4
Liquid propane gas	"w.c.	10	10	10
Max. gas supply pressure *2				
Natural gas	"w.c.	14	14	14
Liquid propane gas	"w.c.	14	14	14
ANSI Z21,13/CSA 4.9				
Thermal efficiency	%	--	94.5	94.5
AHRI, BTS-2000 *B				
Combustion efficiency	%	--	94.2	94.0
Thermal efficiency	%	--	94.0	93.5
A.F.U.E.	%	92.0	--	--
Weight	lbs	194	194	194
	(kg)	(88)	(88)	(88)
Boiler water content	USG	3.4	3.4	3.4
	(L)	(12.8)	(12.8)	(12.8)
Boiler max. flow rate *3	GPM	25	25	25
	(L/h)	(5700)	(5700)	(5700)
Max. operating pressure at 210°F (99°C)	psig	60	60	60
	bar	4	4	4
Boiler water temperature				
- Adjustable high limit (AHL) range space heating (steady state)	°F	68 to 185	68 to 185	68 to 185
	(°C)	(20 to 85)	(20 to 85)	(20 to 85)
DHW production	°F	185	185	185
- Fixed high limit (FHL)	(°C)	(85)	(85)	(85)
	°F (°C)	210 (99)	210 (99)	210 (99)
Boiler connections				
Boiler heating supply and return	NPTM	1½ in.	1½ in.	1½ in.
Pressure relief valve	NPTF	¾ in.	¾ in.	¾ in.
Drain valve	(male thread)	¾ in.	¾ in.	¾ in.
Boiler supply/return for indirect-fired DHW storage tank (field supplied)	NPT	1½ in.	1½ in.	1½ in.
Gas valve connection	NPTF	1 in.	1 in.	1 in.

*A For high altitude installations 5,000 - 10,000 ft. (1500 m - 3000 m), the input for model B2HA 100, 352 will have an altitude de-rating of 14% for 5,000 ft. (1500 m) and 29% for 10,000 ft. (3000 m) average of 2.8% / 1,000 ft. (305 m).

*B Tested to AHRI, BTS-2000 Testing Standard Method to Determine Efficiency of Commercial Heating Boilers.

*1 Output based on 140°F (60°C), 120°F (49°C) system supply/return temperature.

*2 If the gas supply pressure exceeds the maximum gas supply pressure value, a separate gas pressure regulator must be installed upstream of the heating system.

*3 See "Waterside Flow" on page 30 of this manual.

*4 Net AHRI rating based on piping and pick-up allowance of 1.15.

*5 Output based on 180°F (82°C), 80°F (26°C) system supply/return temperature.

Technical Data *(continued)*

Boiler Model No. B2HA		80, 285	88, 311 *A	100, 352 *A
Dimensions				
Overall depth	inches (mm)	21 (530)	21 (530)	21 (530)
Overall width	inches (mm)	19 (480)	19 (480)	19 (480)
Overall height	inches (mm)	43 ½ (850)	43 ½ (1105)	43 ½ *10 (1105)
Flue gas *6				
Temperature (at boiler return temperature of 86°F (30°C))				
- at rated full load	°F (°C)	95 (35)	135 (57)	135 (57)
- at rated partial load	°F (°C)	91 (33)	99 (37)	99 (37)
Temperature (at boiler return temperature of 140°F (60°C))		149 (65)	162 (72)	162 (72)
Max. condensate flow rate *7 for NG and LPG T _S /T _R = 104/86°F (40/30°C)				
	USG/h (L/h)	2.77 (10.5)	3.1 (11.7)	3.5 (13.1)
Condensate connection *8				
	hose nozzle Ø in.	¾-1	¾-1	¾-1
Boiler flue gas connection *9				
	Ø in. (mm)	4 ³ / ₈ (110)	4 ³ / ₈ (110)	4 ³ / ₈ (110)
Combustion air supply connection (coaxial)				
	outer Ø in. (mm)	6 (150)	6 (150)	6 (150)
Sound Rating				
- at maximum input	dB	56	69	69
- at minimum input	dB	38	38	38

*A For high altitude installations 5,000 - 10,000 ft. (1500 m - 3000 m), the input for model B2HA 100, 352 will have an altitude de-ration of 14% for 5,000 ft. (1500 m) and 29% for 10,000 ft. (3000 m) average of 2.8% / 1,000 ft. (305 m).

*6 Measured flue gas temperature with a combustion air temperature of 68°F (20°C).

*7 Based on maximum input rate.

*8 Requires 1 inch (25 mm) tubing. See the Installation Instructions of the Vitodens 200-W, B2HA for details.

*9 For side wall vent installations (coaxial system):
Do not exceed max. equivalent length specified in the Installation Instructions of the Vitodens 200-W, B2HA Venting System.
Vitodens 200-W B2HA 80 to 100, 285 to 352 boilers can only be common vented with other Vitodens 200-W boilers of the same size.
Side wall co-axial vent installation must include Viessmann protective screen!
For details refer to the Installation Instructions for the Vitodens 200-W, B2HA Venting System.

*10 Add approximately 2½ inches (65 mm) for coaxial vent pipe transition adaptor.

For information regarding other Viessmann System Technology componentry, please reference the documentation of each respective product.

Note: For high altitude installation at 10,000 ft. the input for model B2HA 19 to 80, 68 to 285 will have an altitude de-ration of 21%.

Lighting and Operating Instructions

FOR YOUR SAFETY READ BEFORE OPERATING

W A R N I N G: If you do not follow these instructions exactly, a fire or explosion may result causing property damage, personal injury or loss of life.

- A. This appliance does not have a pilot. It is equipped with an ignition device which automatically lights the burner. Do not try to light the burner by hand.
- B. **BEFORE OPERATING** smell all around the appliance area for gas. Be sure to smell next to the floor because some gas is heavier than air and will settle on the floor.
WHAT TO DO IF YOU SMELL GAS
- Do not try to light any appliance.
 - Do not touch any electric switch; do not use any phone in your building.
 - Immediately call your gas supplier from a neighbor's phone. Follow the gas supplier's instructions.
 - If you cannot reach your gas supplier, call the fire department.
- C. Use only your hand to push in or turn the gas control knob. Never use tools. If the knob will not push in or turn by hand, don't try to repair it, call a qualified service technician. Force or attempted repair may result in a fire or explosion.
- D. Do not use this appliance if any part has been under water. Immediately call a qualified service technician to inspect the appliance and to replace any part of the control system and any gas control which has been under water.

OPERATING INSTRUCTIONS

1. **STOP!** Read the safety information above on this label.
2. Set thermostat or other operating control to lowest setting.
3. Turn off all electric power to the appliance.
4. This appliance is equipped with an ignition device which automatically lights the burner. Do not try to light the burner by hand.
5. Close main gas shut-off valve.
6. Wait five (5) minutes to clear out any gas. Then smell for gas, including near the floor. If you smell gas, **STOP!** Follow "B" in the safety information above on this label. If you don't smell gas, go to the next step.
7. Open main gas shut-off valve.
8. Turn on all electric power to the appliance.
9. Set thermostat or other operating control to desired setting.
10. If the appliance will not operate, follow the instructions "To Turn Off Gas To Appliance" and call your service technician or gas supplier.

Manual gas shutoff

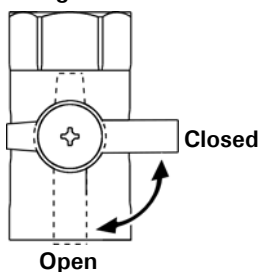

TO TURN OFF GAS TO APPLIANCE

1. Set thermostat or other operating control to lowest setting.
2. Turn off all electric power to the appliance if service is to be performed.
3. Close main gas shut-off valve.

Quick Reference

°C	°F
-40	-40
-35	-31
-25	-13
-20	-4
-18	0
-16	+3
-14	+7
-12	+10
-10	+14
-9	+16
-8	+18
-7	+19
-6	+21
-5	+23
-4	+25
-3	+27
-2	+28
-1	+30
0	+32
+1	+34
+2	+36
+3	+37
+4	+39
+5	+41
+6	+43
+7	+45
+8	+46
+9	+48
+10	+50
+12	+54
+14	+57
+16	+61
+18	+64
+20	+68
+25	+77
+30	+86
+35	+95
+40	+104
+50	+122
+60	+140
+70	+158
+80	+176
+90	+194
+100	+212
+110	+230

Viessmann Manufacturing Company Inc.
 750 McMurray Road
 Waterloo, Ontario • N2V 2G5 • Canada
TechInfo Line 1-888-484-8643
 1-800-387-7373 • Fax (519) 885-0887
 www.viessmann.ca • info@viessmann.ca

Viessmann Manufacturing Company (U.S.) Inc.
 45 Access Road
 Warwick, Rhode Island • 02886 • USA
TechInfo Line 1-888-484-8643
 1-800-288-0667 • Fax (401) 732-0590
 www.viessmann-us.com • info@viessmann-us.com

Printed on environmentally friendly
 (recycled and recyclable) paper.



Technical information subject to change without notice.