



- 80 -



Water & Steam Boilers

For Gas, Light Oil, & Gas/Light Oil-Fired Burners

Boiler Manual

- Installation
- Maintenance
- Startup
- Parts



WARNING

This manual must only be used by a qualified heating installer/service technician. Read all instructions before installing. Follow all instructions in proper order. Failure to comply could result in severe personal injury, death or substantial property damage.

INSTALLER

- Consider piping and installation when determining boiler location.
- Any claims for damage or shortage in shipment must be filed immediately against the transportation company by the consignee.

USER

- This manual is for use only by your qualified heating installer/service technician.
- Boiler and burner must be installed by a qualified service technician.
- We recommend regular service by a qualified service technician, at least annually.

NOTICE

When calling or writing about the boiler— Please have the boiler model number from the boiler rating label and the CP number from the boiler jacket.



Contents

	Page
1. Before installing boiler	3
2. Set boiler in place	5
3. Assemble block.....	6
4. Perform hydrostatic pressure test	8
5. Complete block assembly	9
6. Install flue collector	10
7. Connect water boiler piping	14
8. Connect steam boiler piping.....	16
9. Install jacket	20
10. Pipe tankless heaters	27
11. Install water boiler controls.....	28
12. Install steam boiler controls	29
13. Connect breeching and venting system.....	31
14. Install burner	32
15. Wiring and fuel piping.....	32
16. Make final adjustments.....	32
17. Dimensions and ratings	34
18. Parts	36
Handling ceramic fiber and fiberglass materials.....	38

Hazard Definitions

The following defined terms are used throughout this manual to bring attention to the presence of hazards of various risk levels, or to important information concerning the life of the product.

▲ DANGER Indicates presence of hazards that **will cause severe** personal injury, death or substantial property damage if ignored.

▲ WARNING Indicates presence of hazards that **can cause severe** personal injury, death or substantial property damage if ignored.

▲ CAUTION Indicates presence of hazards that **will or can cause minor** personal injury, death or substantial property damage if ignored.

NOTICE Indicates special instructions on installation, operation or maintenance that are important but not related to personal injury.

▲ WARNING Read all instructions before installing. Failure to follow all instructions in proper order can cause severe personal injury, death or substantial property damage.

▲ WARNING Do not use petroleum-based cleaning or sealing components in boiler system. Severe damage to system components can result, causing substantial property damage.



1 Before installing boiler

Installation must comply with —

- State, provincial and local plumbing, heating and electrical codes.
- Regulations of servicing utilities.
- National codes where applicable.

Before selecting boiler location

1. Check for nearby connections to:
 - a. Fuel supply
 - b. Electrical power
 - c. System water or steam piping
 - d. Venting systems - see page 31
 - e. Combustion and ventilation air supply — see “Provide combustion and ventilation air supply openings” on page 4.
2. Check area around boiler. Remove any combustible materials, gasoline and other flammable vapors and liquids.



Failure to keep boiler area clear and free of combustible materials, gasoline and other flammable liquids and vapors can result in severe personal injury, death and substantial property damage.

Provide clearance around boiler

- Provide minimum clearances to combustible materials:
 1. Single-wall vent pipe – 18 inches.
 2. Double-wall vent pipe – refer to vent pipe manufacturer’s recommendations for vent pipe clearances.
 3. Boiler top — 24 inches.
 4. Boiler front — 48 inches.
 5. Boiler flue — 9 inches.
 6. Boiler rear — 9 inches.
 7. Boiler sides — 6 inches.
- Boiler may be installed on combustible flooring.
- See pages 34 and 35 for boiler dimensions.



Flue pipe/breeching clearances take precedence over jacket clearances.

- Left side — for cleaning and tankless heater removal – 34 inches.
- Allow sufficient space on remaining sides for cleaning, servicing and burner installation. See burner literature for length and recommended service clearances.

Lay a foundation, if needed:

Floor construction and condition must be suitable for weight of boiler when filled with water. See page 34 for approximate boiler operating weight.

A level concrete or brick foundation (constructed per Table 1 and Figure 1) is required when:

1. A floor could possibly become flooded.
2. Non-level conditions exist.

Table 1 Boiler foundation (see Figure 1)

Boiler model number	“L” Length, (inches)	Boiler model number	“L” Length, (inches)
380	23	880	58
480	30	980	65
580	37	1080	72
680	44	1180	79
780	51	1280	86

Figure 1 Boiler foundation

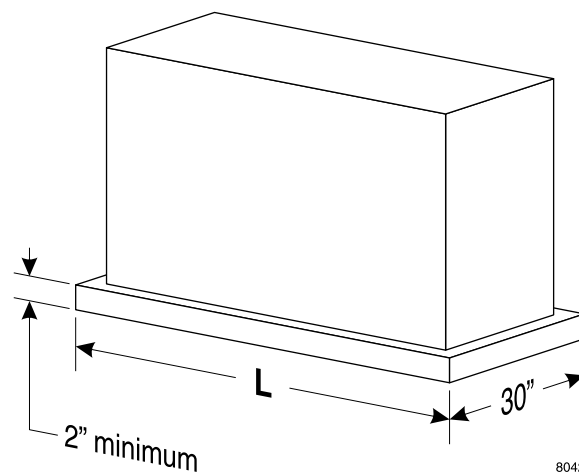

8042

1

Before installing boiler (continued)

Provide combustion and ventilation air openings:

⚠ WARNING

Do not install an exhaust fan in boiler room. Adequate combustion and ventilation air must be provided to assure proper combustion and prevent possibility of flue gas leakage and carbon monoxide emissions, causing severe personal injury or death.

Opening sizes must comply with state, provincial or local codes. In their absence, use the following when boiler is in a confined room:

- Provide two permanent openings in boiler room — one within 12 inches of ceiling, one within 12 inches of floor. Minimum dimension of each opening is 3 inches.
 1. When all air is taken from within building, each opening should be at least one square inch/1,000 Btuh boiler input and freely connect with areas having adequate infiltration from outside.
 2. When all air is taken from outdoors, each opening should connect directly or by ducts from outdoors or crawl or attic spaces that freely connect with outdoors and sized as listed below:
 - a. through outside wall or vertical ducts - at least one square inch/4,000 Btuh boiler input.
 - b. through horizontal ducts - at least one square inch/2,000 Btuh boiler input.
 - c. where ducts are used, they should be same cross-sectional area as free area of openings they are connected to.
 - d. compensate for louver, grille or screen blockage when calculating free air openings. Refer to their manufacturer's instructions for size. If unknown, use:
 - wood louvers - 20-25% free air.
 - metal louvers or grilles - 60-75% free air.
 - screens - not less than ¼ inch mesh.

Lock louvers in open position, or interlock with equipment to prove open before boiler operation.

When combustion and ventilation air enters through sidewall openings, ensure openings comply with Figures 2 and 3.

Figure 2 Combustion and ventilation air openings — Boiler room below grade

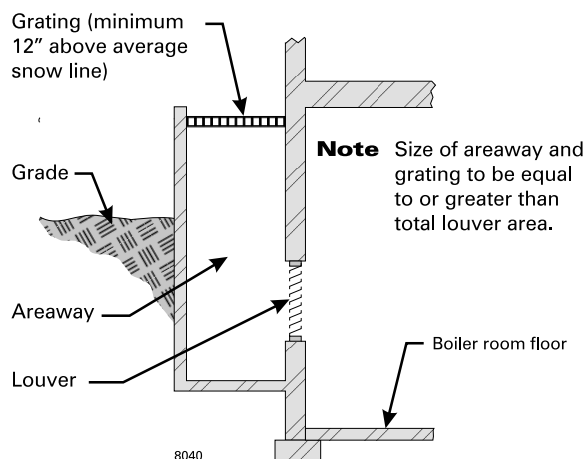
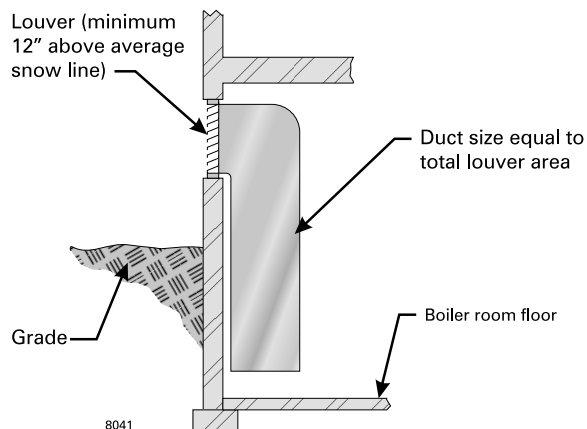

Figure 3 Combustion and ventilation air openings — Boiler room partially or completely above grade





2 Set boiler in place

For packaged boiler:

1. Remove top jacket panels. Set aside until after boiler is piped.

⚠WARNING The boiler contains ceramic fiber and fiberglass materials. Use care when handling these materials per instructions on page 38 of this manual. Failure to comply could result in severe personal injury.

2. Remove lag screws (2 in front, 2 in rear) from shipping rails.
3. Remove boiler from skid. Cables are already attached to block assembly. See Table 2 for lifting weight.
 - Using crane — hook middle of each cable to eye of crane.
 - Using hoist — hook middle of each cable to hoist. Raise boiler off skid. Use pipe rollers under skid angles to roll boiler.
4. Place boiler in final position. Center boiler on foundation, if used.
5. Level boiler. Shim under skid angles, if necessary.
6. Cut off cables.

⚠WARNING Cables are not intended for long-term usage. Cables may corrode inside boiler, weakening their lifting strength. Failure to remove cables can result in severe personal injury, death or substantial property damage.

7. Proceed to “Perform hydrostatic pressure test,” page 8.

For block assembly:

1. Remove lag screws (2 in front, 2 in rear) from shipping rails.
2. Remove boiler from skid. Cables are already attached to block assembly. See Table 2 for lifting weight.
 - Using crane – attach free end of cables to eye of crane.
 - Using hoist – attach free end of cables to hoist. Raise boiler off skid. Use pipe rollers under steel skid angles to roll boiler.
3. Place boiler in final position. Center boiler on foundation, if used.
4. Level boiler. Shim under skid angles, if necessary.
5. Cut off cables.

⚠WARNING Cables are not intended for long-term usage. Cables may corrode inside boiler, weakening their lifting strength. Failure to remove cables can result in severe personal injury, death or substantial property damage.

6. Inspect block assembly for disjointed sections. Check gas-tight seal of flue collector hood and cleanout plates.

⚠WARNING Gas tight seal must be maintained to prevent possible flue gas leakage and carbon monoxide emissions, resulting in severe personal injury or death.

- a. Check inside section assembly for any light passing through unsealed areas.
 - b. Mark all unsealed areas.
 - c. At unsealed areas, check for:
 - damaged gaskets.
 - sealing rope not in place.
 - loose bolts or nuts.
 - d. Correct all conditions and repeat step b. If unsealed areas still exist, contact your Weil-McLain distributor or sales office before continuing installation.
7. Proceed to “Perform hydrostatic pressure test,” page 8.

Table 2 Lifting weights

Boiler model number	Packaged boiler lbs.	Assembled block lbs.
380	1355	1150
480	1615	1385
580	1875	1620
680	2130	1855
780	2390	2090
880	2650	2325
980	2910	2560
1080	3165	2795
1180	3425	3030
1280	3680	3265

3 Assemble block

WARNING Sections are top heavy. Unbolted sections may fall if not supported, resulting in severe personal injury or death.

Install back refractory blanket

1. Lay back section on floor with ports face up.
2. Apply adhesive to blanket.
3. Press blanket against back target wall as shown in Figure 4.
4. Using knife, cut hole through blanket to expose observation port opening.

Prepare back section

1. Apply $\frac{1}{8}$ " continuous bead of sealing rope adhesive in sealing rope grooves. See Figure 4. **Do not get any adhesive on machined port surfaces.**
2. Place $\frac{1}{2}$ " sealing rope in groove. Around curves, grasp at 1" intervals and push together. Do not stretch.

WARNING Do not pre-cut rope. Gas tight seal must be maintained to prevent possibility of flue gas leakage and carbon monoxide emissions, causing severe personal injury or death.

3. Remove any grit from port machined surfaces with clean rag.

WARNING Do not use petroleum-based cleaning or sealing compounds in boiler system. Severe damage to system components can result, causing substantial property damage.

4. Place $7\frac{1}{2}$ " and $3\frac{1}{2}$ " sealing rings in appropriate port openings. See Figure 4. If sealing ring slips out of groove, stretch ring gently for several seconds, then reposition in groove.
5. Apply continuous bead of silicone sealant no larger than $\frac{1}{16}$ " around entire outside edge of **outer** machined surface of port. Refer to Figure 5. **Do not apply silicone sealant on, next to or under sealing ring.**

WARNING Silicone sealant applied as specified above prevents unburned oil vapors from coming in contact with sealing ring. Vapor contact can damage rings, resulting in severe damage to boiler and substantial property damage.

6. Position section upright on foundation (if used) and screw 3" pipe at least 22" long into 3" return tapping.
7. Place a block under pipe to hold section upright.

Figure 4 Sealing rope installation

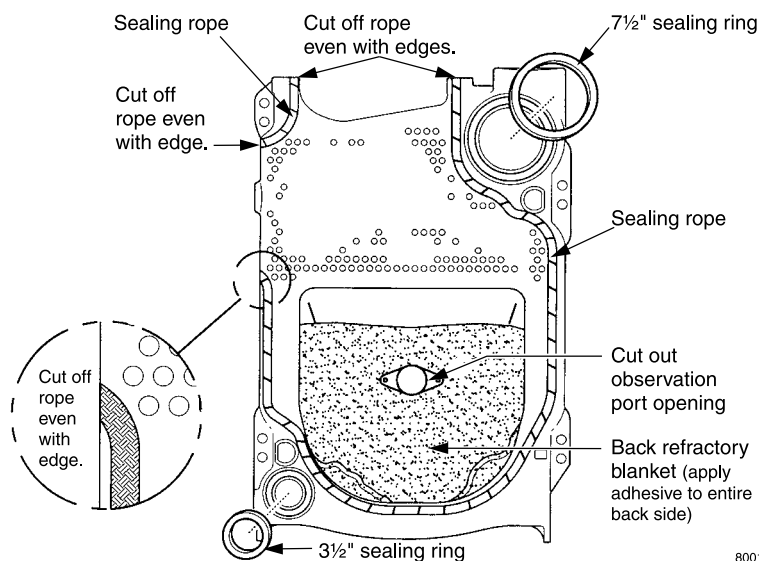
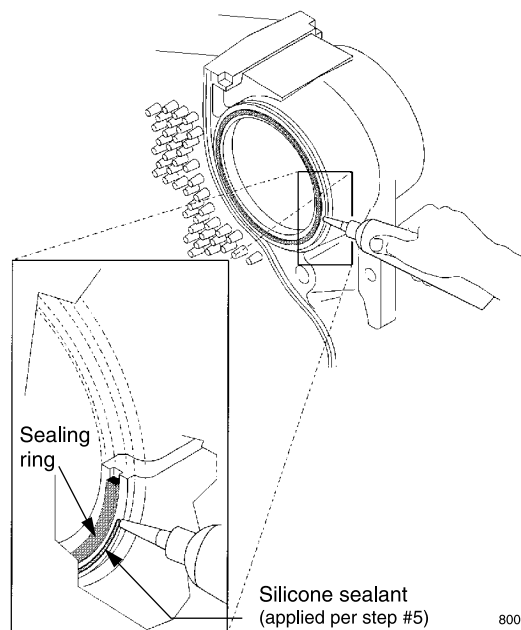

Figure 5 Silicone sealant





3 Assemble block (continued)

Install intermediate sections

WARNING Sections are top heavy. Unbolted sections may fall if not supported, resulting in severe personal injury or death.

1. Remove and discard $\frac{3}{8}$ " diameter shipping tie rods.
2. Remove grit from port machined surfaces with clean rag.

WARNING Do not use petroleum-based cleaning or sealing compounds in boiler system. Severe damage to system components can result, causing substantial property damage.

3. Position intermediate section so aligning lugs fit into sockets of next section. See Figure 6.
4. Install TI (tankless intermediate) and SI (supply intermediate) sections (when used) in order shown in Table 3.
5. Draw sections together until metal-to-metal contact is made around machined port openings (see Figure 6):
 - a. Oil threads on 4 draw rods. Install washer and nut on end to be tightened. Use nut only on other end.
 - b. Uniformly draw sections together, starting at washer/nut end.

NOTICE **Important** — Leave an equal amount of thread on each end of the draw rod. This is needed to allow securing the jacket support brackets in place (see pages 20 and 21).

- c. Draw rods should be torqued to a range of 90 to 100 ft. - lbs. Do not back off draw rods.
 - d. Metal-to-metal contact will be achieved around port openings. See Figure 6. If gap occurs, it should be no greater than .032". Check with feeler gauge.
 - e. If, for any reason, gap around machined port opening exceeds .032", check for rope extending from rope grooves, dirt on port openings or sockets, or misaligned lugs. If corrections are made and gap still exists, contact your Weil-McLain distributor or sales office before continuing installation.
6. **CAUTION** After erecting first intermediate section, check both sections for plumb. Failure to plumb sections can cause misaligned piping and breeching, possibly resulting in property damage.
 7. Repeat steps 1-5 from "Prepare back section," page 6.

Install bottom refractory blanket on combustion chamber floor inside section block

1. Unroll blanket only to depth of back section and first intermediate section.
2. Spread adhesive on bottom side of blanket.
3. Press blanket into center bottom of sections.
4. Unroll and install blanket per steps 2 and 3 as each intermediate and front section are installed.
5. At front section, cut off blanket $2\frac{1}{2}$ " from burner opening. Discard unused blanket.

Prepare remaining sections

1. Follow "Prepare intermediate section" for remaining intermediate and front sections:
 - a. Remove any grit from threads inside tapped holes with clean rag.

Figure 6 Sealing ring installation and port alignment

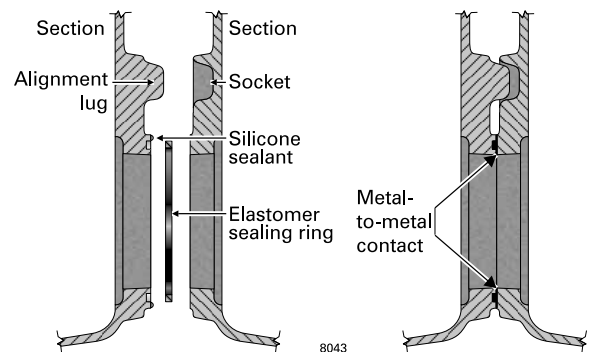

Table 3 Section arrangement

Boiler model number	Max. number of heaters	Section arrangement (all heaters must be on left side of boiler)
380 W&S	1	F-TI-B
480 W&S	1	F-TI-I-B
580 W&S	2	F-TI-I-TI-B
680 W&S	2	F-TI-I-TI-I-B
780 W&S	2	F-TI-I-TI-I-I-B
880 W&S	3	F-TI-I-TI-I-I-TI-B
980 W&S	3	F-TI-I-TI-I-TI-I-I-B
1080 W	3	F-TI-I-TI-I-I-TI-I-I-B
1080 S	3	F-TI-I-TI-SI-I-TI-I-I-B
1180 W	4	F-TI-I-TI-I-I-I-TI-I-TI-B
1180 S	4	F-TI-I-TI-I-SI-I-TI-I-TI-B
1280 W	4	F-TI-I-TI-I-I-I-I-TI-I-TI-B
1280 S	4	F-TI-I-TI-I-SI-I-I-TI-I-TI-B

W = water / S = steam
 F = front / B = back / I = Intermediate
 TI = tankless intermediate
 SI = supply intermediate for steam boilers.
 "I" sections can be substituted for "TI" sections.

WARNING Do not use petroleum-based cleaning or sealing compounds in boiler system. Severe damage to system components can result, causing substantial property damage.

- b. Check each section for proper sealing rope position before proceeding to next section.

WARNING Failure to position sealing rope properly can cause boiler to not seal gas-tight. Gas tight seal prevents possible flue gas leakage and carbon monoxide emissions, resulting in severe personal injury or death.

If using tankless heater (TI) sections

1. Install tankless heaters and gaskets or heater cover plates and gaskets. Use $\frac{3}{8}$ " x $\frac{3}{4}$ " studs, washers and nuts.



4 Perform hydrostatic pressure test

Prepare boiler and test:

1. See pages 28 and 29 for tapping locations. Install:
 - a. Boiler drain (not furnished).
 - b. Water pressure gauge — for test only. Be sure gauge can handle test pressure — see step 3.
 - c. Air vent in upper tapping (K).
2. Plug remaining tappings.

CAUTION Do not pressure test with any control installed. Damage to control can occur due to overpressure.

3. Fill boiler. Vent all air. Pressure test at least 10 minutes at a pressure not less than the following:
Steam boiler:
Between 45 and 55 psig.
Water boiler:
1½ times maximum allowable working pressure (MAWP) stamped on the boiler nameplate, located on boiler jacket front panel.

NOTICE Do not exceed above test pressures by more than 10 psig.

WARNING Do not leave boiler unattended. Cold water fill could expand and cause excessive pressure, resulting in severe personal injury, death or substantial property damage.

4. Check for maintained gauge pressure and leaks. Repair if found.

WARNING Leaks must be repaired at once. Failure to do so can damage boiler, resulting in substantial property damage.

WARNING Do not use petroleum-based cleaning or sealing compounds in boiler system. Severe damage to system components can result, causing substantial property damage.

5. Drain boiler and remove air vent, boiler drain and gauge. Remove plugs from tappings that will be used for controls and accessories.

5 Complete block assembly

Install burner mounting plate on front section

1. Install four 1/2" x 4 3/4" studs to secure burner mounting plate to section:
 - a. Thread and lock together two nuts on rounded end of stud. Thread flat end of stud into one of four holes located around opening.
 - b. Remove nuts.
 - c. Repeat steps a and b for remaining studs.
2. Install burner mounting plate:
 - a. Apply 1/8" continuous bead of sealing rope adhesive in groove around opening in section.
 - b. Position 1/2" sealing rope in groove. Overlap ends at least one inch.
 - c. Install burner mounting plate. Use 1/2" washers and nuts.

Install observation port assemblies on front and back sections:

1. Install front observation port assembly:
 - a. Apply 1/8" continuous bead of sealing rope adhesive in groove on observation port.
 - b. Position 3/8" sealing rope in groove.
 - c. Secure assembly to section. Use 5/16" - 18 x 3/4" slotted head screws.
2. Repeat above steps for back observation port assembly.

Install cleanout plates



Cleanout plates must be installed gas-tight to prevent possibility of flue gas leakage and carbon monoxide emissions, resulting in severe personal injury or death.

1. See Figure 7. Position two 1/4" x 1 3/4" carriage bolts in cleanout opening. Secure with washers and nuts.
2. Place blanket insulation piece against cleanout plate.
3. Mount cleanout plate over opening. Secure with nuts and washers.
4. Repeat steps 1 through 3 for remaining cleanout plates.



The boiler contains ceramic fiber and fiberglass materials. Use care when handling these materials per instructions on page 38 of this manual. Failure to comply could result in severe personal injury.

Figure 7 Cleanout plate assembly

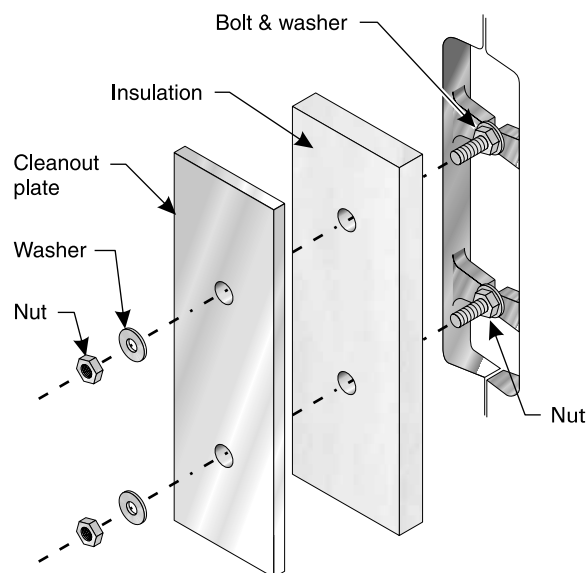

8025

6 Install flue collector

Flue collector assembly

- Figure 10, page 11, shows flue collector components and locations. Figure 11, page 13, shows collector hoods for all models. Follow all instructions in this manual to ensure correct installation of the flue collector.
- Model 80 boilers are available with either rear flue or top flue. Verify that you have the correct components for your application. You can convert a Model 80 from rear to top or top to rear flue using a flue conversion kit, available from your Weil-McLain distributor.

NOTICE

The flue outlet for top flue models must be located as shown in this manual.

Install collector hold-down bolts

- Figure 10, lower left — Install a collector hold-down bolt assembly at each section joint, and on both sides of the boiler section assembly. Set aside the flanged nuts for securing the collector assembly when it is ready.
- Each hold-down bolt assembly consists of a $\frac{5}{16}$ " x 2" carriage bolt, flat washer, regular hex nut and a flanged nut as shown.

Prepare flue collector hood assembly

WARNING

Make sure gaskets are intact, not torn or otherwise damaged. These conditions can cause possible flue gas leakage and carbon monoxide emissions, resulting in severe personal injury or death.

WARNING

The boiler contains ceramic fiber and fiberglass materials. Use care when handling these materials per instructions on page 38 of this manual. Failure to comply could result in severe personal injury.

- Stand flue collector hood front module (item 4) on end as in Figure 8, left side.

- Wipe all flanged surfaces with clean rag.
- Lay flue collector hood gasket (item 2) on flange.
- Place flue collector end cap (item 1) on gasket. Align bolt holes. Secure with seven $\frac{5}{16}$ " x $\frac{5}{8}$ " flanged bolts and flanged nuts. **Tighten to between 30 and 35 inch-pounds torque.** (See WARNING on page 12, top right column.)
- For 880 - 1280:
 - Stand remaining hood module on end, as in Figure 8, right side.
 - Wipe all flanged surfaces with clean rag.
 - Lay gasket on flange.
 - Carefully place open end of first module on top of gasket, aligning flanged surfaces.
 - Secure with seven $\frac{5}{16}$ " x $\frac{5}{8}$ " flanged bolts and flanged nuts. **Tighten to between 30 and 35 inch-pounds torque.** (See WARNING on page 12.)
- Attach flat-stitched sealing rope to hood assembly. See Figure 9:
 - Lay hood on floor with flanged side up.
 - Wipe flanged surface with clean rag to remove dirt and oil.
 - Apply double-faced tape to flanged surface.
 - Apply rope to tape beginning on one side of open end of hood, leaving $\frac{1}{4}$ " extending past edge. Bend rope around corners. **DO NOT cut or stretch rope.**

WARNING

Do not pre-cut rope. All collector hood joints must be sealed gas-tight to prevent possible flue gas leakage and carbon monoxide emissions, resulting in severe personal injury or death.

- Continue around entire flange. At other open end, leave $\frac{1}{4}$ " rope extending past edge of flange. Cut off excess rope.

NOTICE

Double-faced tape serves only to hold sealing rope in place during installation. It will disintegrate over time. If collector hood and sealing rope are removed for any reason, install new tape and new gasket.

Figure 8 Collector hood preparation

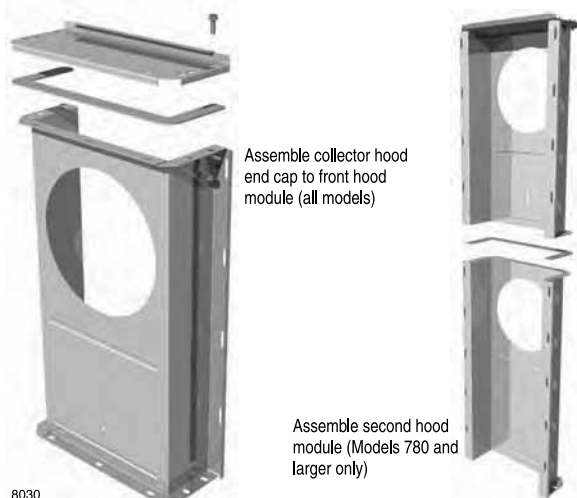
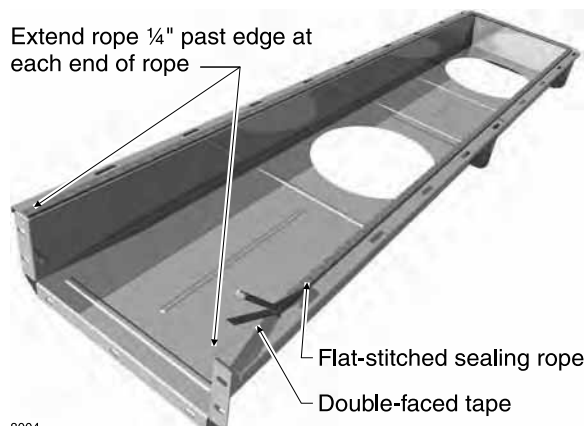

Figure 9 Flue collector sealing rope installation





6 Install flue collector (continued)

Figure 10 Flue collector components, typical (Model 880 collector configurations shown)

Flue collector components

- 1 Flue collector end cap
- 2 Flue collector hood gasket
- 3 Flue collector hood, rear
- 4 Flue collector hood, front
- 5 Flue damper assembly, top flue
- 6 Flue cap (top)
- 7 Circular flue collector gasket
- 8 Rectangular flue collector gasket
- 9 Flue cap, rear
- 10 Flue collector hood transition
- 11 Flanged bolts, 5/16" x 5/8"
- 12 Flanged nuts, 5/16"
- 13 Sheet metal screw, AB pan head Phillips #10 x 1/2"
- 14 Flue damper assembly, rear flue

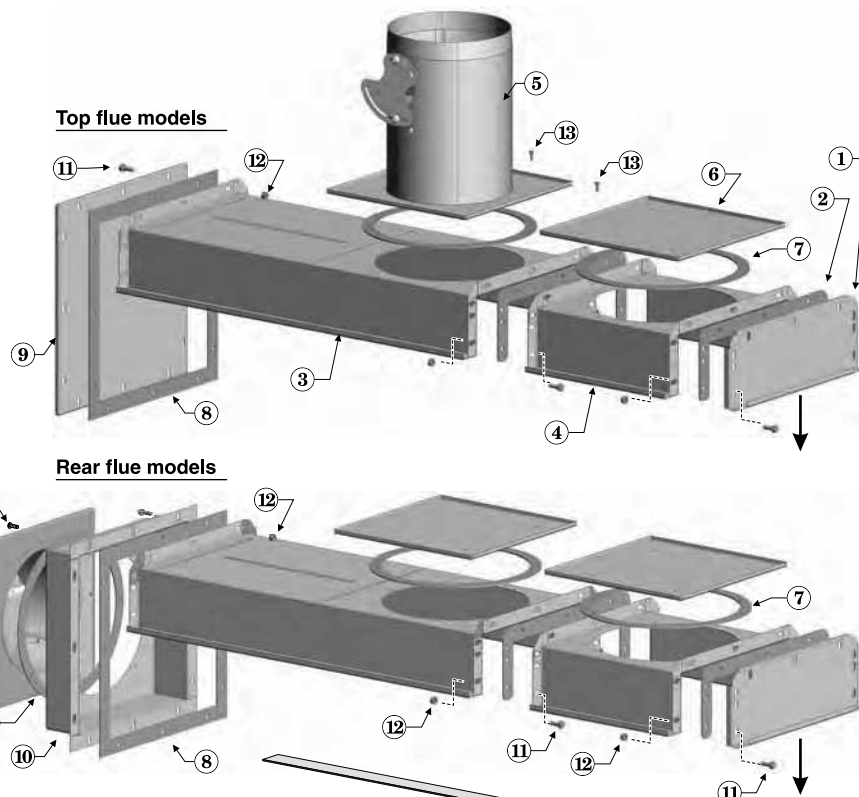

Sealing flue collector to section assembly

Double-faced tape (applied to flue collector after cleaning)

Flat-stitched sealing rope (applied over tape)

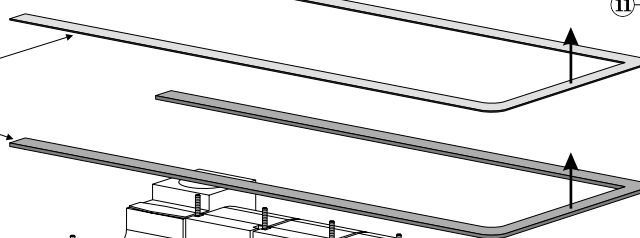

Flue collector hold-down bolt installation

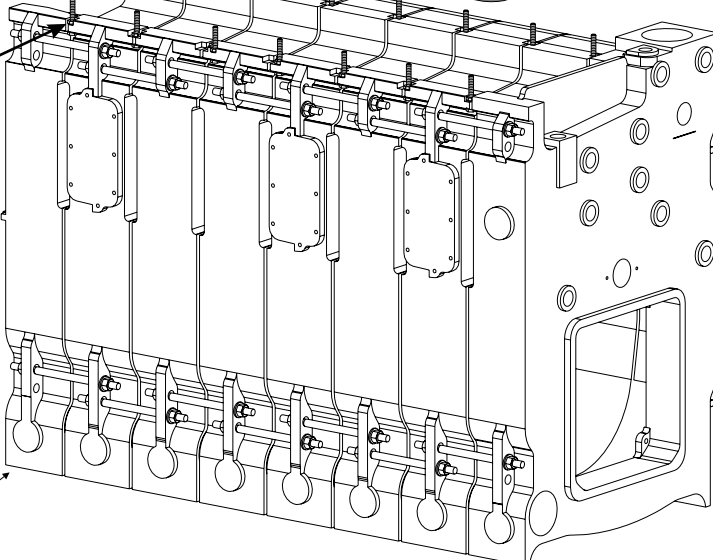
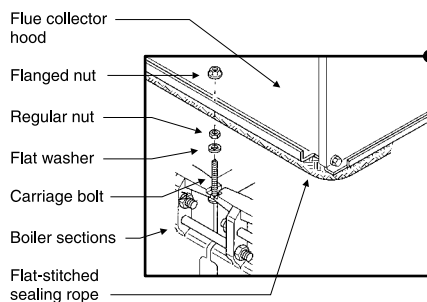

Section assembly, typical

Flue collector bolts to section assembly as shown (Model 880 shown)



6 Install flue collector (continued)

Before installing flue collector

1. See Figure 10, page 11, for general assembly of flue collector components.
2. See Figure 11, page 13 for the placement of flue collector hoods on each model.
3. Prepare mounting holes in boiler rear section.
 - a. The boiler rear section has tapped holes for mounting rear flue collector component.
 - b. Remove any grit from threads inside tapped holes with clean rag.

Rear flue boilers only:

1. See Figure 10, page 11 and Figure 11, page 13.
2. Place collector hood transition on rear section:
 - a. Wipe item 10, Figure 10, **collector hood transition** flange surfaces with a clean rag.
 - b. Apply a few pieces of double-faced tape on the collector hood transition flange.
 - c. Place the **collector hood transition gasket** (item 8, Figure 10) on the collector hood transition flange. Align holes in gasket with holes in flange. Press gasket firmly in place.
 - d. Position collector hood transition on back of boiler rear section, aligning collector hood transition flange holes with tapped holes in boiler rear section.
 - e. Insert a 5/16" x 5/8" flanged bolt through the bottom center hole and finger tighten to hold transition in place.
 - f. Install six remaining bolts securing collector hood transition to rear section. **Finger-tighten** only.
3. Place collector hood assembly on sections:
 - a. Carefully set collector hood assembly on top of section assembly. Align slotted holes in collector hood flanges with the hold-down bolts in the sections.
 - b. Place the collector hood assembly so its rear flange is against the collector hood transition flange gasket.
 - c. Thread flanged nuts onto hold-down bolts and **finger-tighten** only.
 - d. Insert five 5/16" x 5/8" flanged bolts through holes in collector hood transition and collector hood assembly rear flange. Thread on nuts and **finger-tighten** only.
4. Tighten flue collector bolts and nuts:
 - a. Gradually tighten all bolts and nuts on flue collector assembly and boiler. **Tighten to between 30 and 35 inch-pounds torque**. See **WARNING**, upper right.
 - b. Alternate locations as you tighten the fasteners to ensure all parts are evenly drawn down, with no gaps or distortion of parts.
5. Install damper and flue caps:
 - a. Wipe item 5, Figure 10, **flue damper** flange surface with a clean rag.
 - b. Apply a few pieces of double-faced tape to the flue damper flange. Position flue collar gasket on damper and press firmly in place. Align all holes before securing.
 - c. Position flue damper assembly against collector hood transition. Insert a #10 x 1/2" screw through the top center hole. Lightly tighten to hold flue damper in position.
 - d. Insert remaining #10 screws into flue damper flange and lightly tighten. Alternate from screw to screw and tighten all screws evenly and securely.
 - e. Install flue caps on flue collector top opening(s) using steps 5a through 5d.

WARNING

DO NOT overtighten bolts in flue collector hood assembly. Gasket material could extrude, causing possible flue gas leakage and carbon monoxide emissions, resulting in severe personal injury or death.

Top flue boilers only:

1. See Figure 10, page 11 and Figure 11, page 13.
2. Place rear flue cap on rear section:
 - a. Wipe item 9, Figure 10, **rear flue cap** gasket surface with a clean rag.
 - b. Apply a few pieces of double-faced tape on the rear flue cap gasket surface.
 - c. Place the **rectangular gasket** (item 8, Figure 10) on the flue cap, aligning holes in gasket with holes in rear flue cap. Press firmly in place.
 - d. Position rear flue cap on back of boiler rear section, aligning rear flue cap holes with tapped holes in boiler rear section.
 - e. Insert a 5/16" x 5/8" flanged bolt through the bottom center hole and finger tighten to hold rear flue cap in place.
 - f. Install six remaining bolts securing rear flue cap to rear section. **Finger-tighten** only.
3. Place collector hood assembly on sections:
 - a. Carefully set collector hood assembly on top of section assembly. Align slotted holes in collector hood flanges with the hold-down bolts in the sections.
 - b. Place the collector hood assembly so its rear flange is against the rear flue cap gasket.
 - b. Thread flanged nuts onto hold-down bolts and **finger-tighten** only.
 - c. Insert five 5/16" x 5/8" flanged bolts through holes in rear flue cap and collector hood assembly rear flange. Thread on nuts and **finger-tighten** only.
4. Tighten flue collector bolts and nuts:
 - a. Gradually tighten all bolts and nuts on flue collector assembly and boiler. **Tighten to between 30 and 35 inch-pounds torque**. See **WARNING**, above.
 - b. Alternate locations as you tighten the fasteners to ensure all parts are evenly drawn down, with no gaps or distortion of parts.
5. Install damper and flue caps (see Figure 11, page 13):
 - a. Wipe item 5, Figure 10, **flue damper** flange surface and flue collector assembly surfaces with a clean rag.
 - b. Position **round gasket** (item 7, Figure 10) on flue collector assembly **in the flue location shown in Figure 11, page 13**. Align bolt holes.
 - c. Place flue damper assembly on gasket. (See **NOTICE**, below.) Insert #10 x 1/2" screws through the holes. Alternate from screw to screw and tighten all screws evenly and securely.

NOTICE

Model 380 top flue applications — always mount the damper assembly with the damper adjustment plate pointed toward the rear of the boiler as shown in Figure 11. Otherwise, the jacket top panels may be difficult to install.

- e. Install flue cap on remaining top opening (if any) using steps a through c, above.

After installing flue collector, ALL BOILERS

1. Check for gas-tight seal of all flue collector hood components.

WARNING

All collector hood joints must be sealed gas-tight to prevent possible flue gas leakage and carbon monoxide emissions, resulting in severe personal injury or death.

- a. Open flue damper. Visually inspect inside section assembly and flue collector assembly for any light passing through unsealed areas.
- b. Mark all unsealed areas.
- c. Check unsealed areas for cause — damaged gaskets, sealing rope not in place, or loose bolts or nuts.
- d. Correct all conditions and repeat inspection procedure.
- e. If unsealed areas cannot be eliminated, discontinue the boiler installation. Contact your Weil-McLain distributor or sales office for assistance.



6 Install flue collector (continued)

Figure 11 Flue collector components by model (see Figure 10, page 11 for flue collector components not shown below)

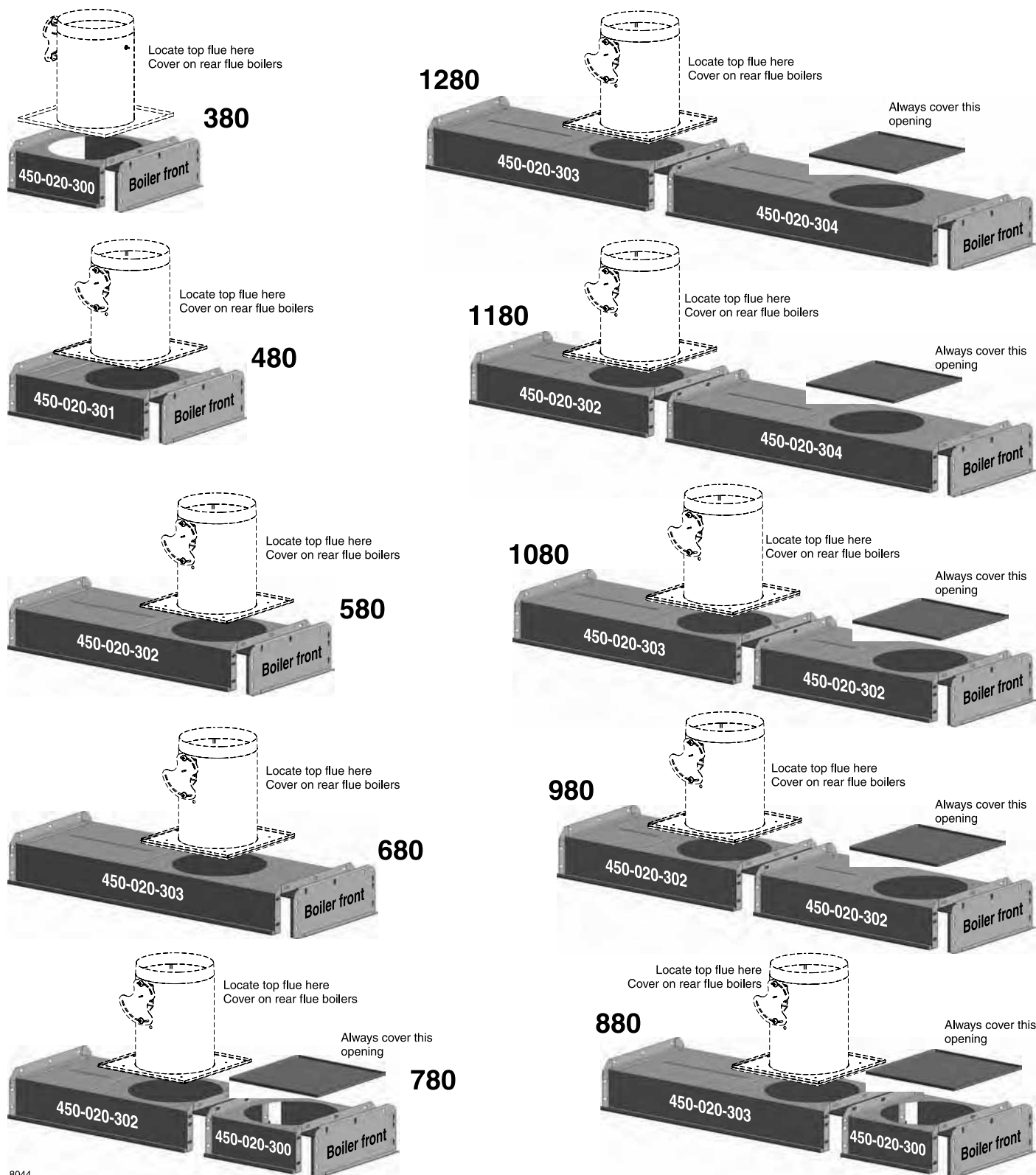

8044



7 Connect water boiler piping

General water piping information:

- System water supply and return piping should be installed and piping connections attached to boiler before erecting jacket or installing controls.
- Do not pipe in through supply and out through return. This creates reverse water flow through boiler that must not be used.
- When three-way valves are used for temperature modulation, install slow-opening (minimum 10-minute) valves and boiler mixing pump to minimize potential of boiler thermal shock. See W-M Tech Bulletin SB-0203.

Install piping:

Install piping as shown in Figure 12 for single boilers. For multiple boilers, see Figure 13, page 15.

CAUTION Improperly piped systems or undersized piping can contribute to erratic boiler operation and possible boiler or system damage.

1. Connect supply and return piping:
 - a. Size according to tables below.
 - 1) For **unknown flow rates**, size piping per Table below, using 20°F temperature rise through boiler.
 - 2) For **known flow rates or higher flow rate** through boiler, size piping per Table below.

WARNING Flow at higher rates than shown in Table below for pipe size can damage boiler, causing substantial property damage.

- b. Locate circulator in supply piping.
 - c. For return piping, use full diameter pipe for 10 times that diameter before making any reduction. For example, a 4-inch return should not be reduced any closer to boiler return tapping than 40 inches.
 - d. Install system blow-off (drain) valve in lowest part of return piping close to boiler. ASME minimum size requirements are shown in Table 6.
2. Install expansion tank:
 - a. **Closed type** – connect to 1” tapping “K” (refer to pages 28 and 29). Use 1” N.P.T. piping. Any horizontal piping must pitch up toward tank at least 1 inch per each 5 feet of piping.
 - b. **Diaphragm type** – Refer to tank manufacturer’s literature for location. Install automatic air vent in “K” tapping.
 - c. Connect cold water fill to expansion tank piping. See Figure 12, page 14. Also shown are recommended valves and water meter, when used. Water meter will detect added make-up water, indicating leaks in system.

Table 4 Recommended minimum pipe sizes when flow rate is not known (see Figure 12)

Boiler model number	Supply pipe size A	Return pipe size B
380	2”	2”
480	2½”	2½”
580– 680	3”	3”
780–1280	4”	4”

Table 5 Recommended minimum pipe sizes for known flow rates.

Water flow rate GPM	Supply pipe size A	Return pipe size B
Up to 35	2”	2”
36–50	2½”	2½”
51–77	3”	3”
78–142	4”	4”

Table 6 ASME drain valve size

Boiler model number	Valve size
380 – 480	¾”
580 – 1180	1”
1280	1¼”

Figure 12 Water boiler piping, typical

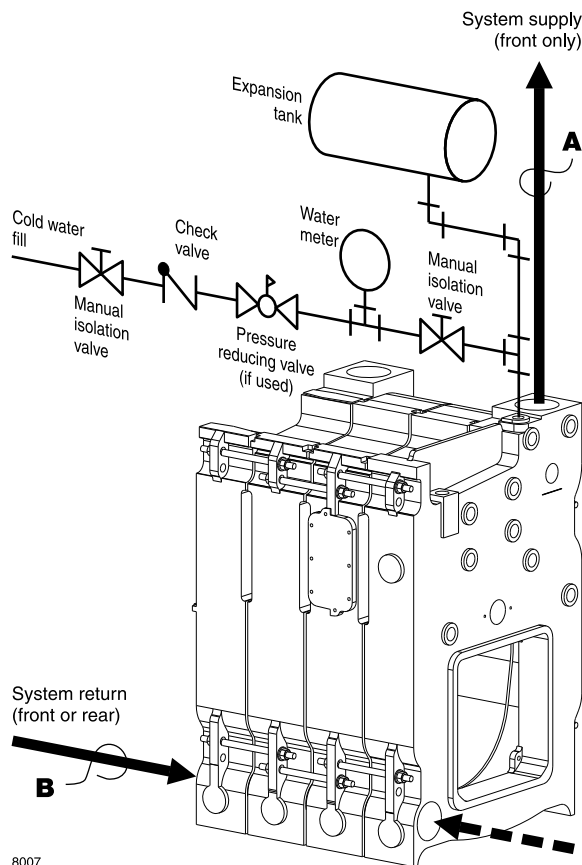



7 Connect water boiler piping (continued)

3. Piping for multiple boilers (see Figure 13):

A Size secondary boiler pump GPM based on following formulas:

$$\frac{\text{Gross output}}{\text{Temperature rise} \times 500} = \text{GPM}$$

Temperature rise, °F = 230°F - Return water temperature
Gross output is in Btuh.

Calculate only secondary piping circuit resistance. Boiler resistance will be about equal to three 90 degree elbows of secondary pipe size. Operate each boiler and its secondary pump from a Weil-McLain boiler control panel. **Do not** maintain boiler at predetermined water temperature.

B Primary pump GPM and head calculation should not include secondary boiler circuits. Primary pump can operate continuously during heating season.

C Space 12" maximum or as close as practical.

D Check valve.

E Hand valve.

Expansion tank(s), relief valves and other accessories are required but not shown.

Figure 13 Multiple water boiler piping

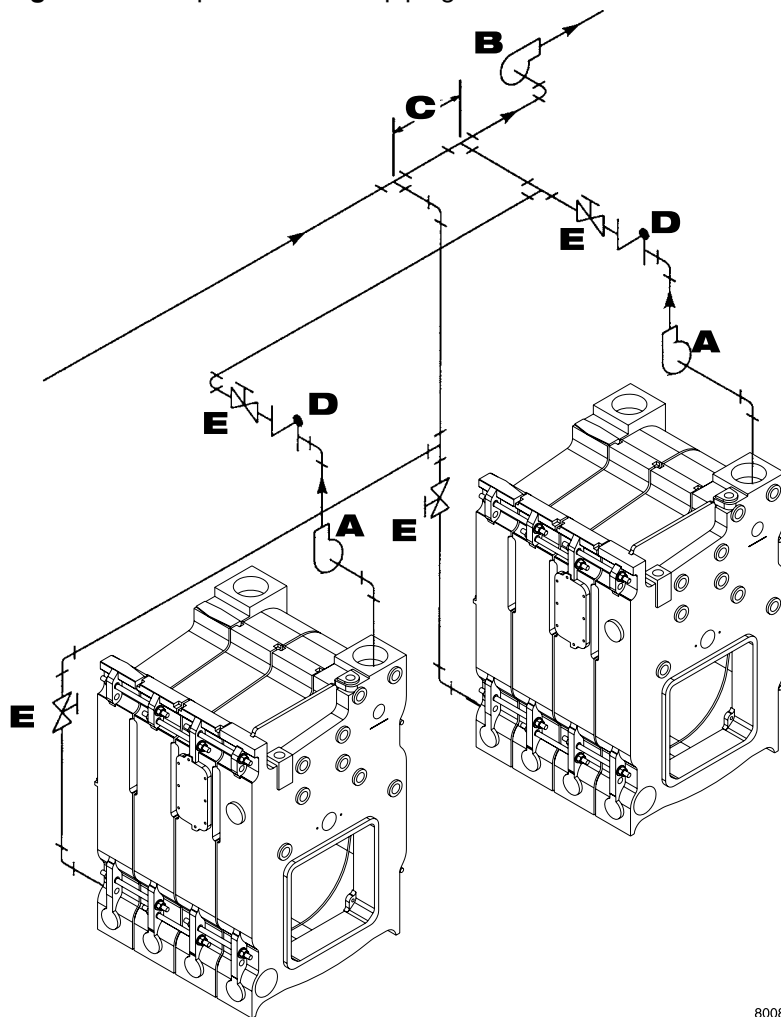



8 Connect steam boiler piping

General steam piping information:

- Hartford loop piping arrangement and wet return are required for steam boilers. Use the Hartford loop for both pumped-return and gravity-return systems.
- Maintain 24-inch minimum from waterline to bottom of header (56¼" from bottom of section).
- When using condensate receiver, feed pump must be energized by boiler-mounted pump controller. Install piping:

Install piping as shown on pages 16 through 18 for single boilers. See page 19 for additional requirements when piping multiple boilers.



Improperly piped systems or undersized piping can contribute to erratic boiler operation and possible boiler or system damage. Piping system must be installed as shown, using pipe sizes shown. Pipe sizes shown are for two-pipe, pumped-return systems. Adjust pipe sizing as needed when connecting to gravity-return systems. Consult local Weil-McLain distributor or sales office before installing alternate piping.

1. Connect supply and return piping:
 - a. See Table 7.
 - 1) Size condensate return piping by pump.
 - 2) Size gravity condensate return same as equalizer "J" pipe size.
 - b. Install system drain valve in lowest part of return piping close to boiler. ASME size requirements are shown in Table 6, page 14.
 - c. Connect cold water fill piping as shown in Figure 14.

- Also shown are recommended valves and water meter, if used. Water meter will detect added makeup water, indicating leaks in system.
2. Condensate piping:
 - a. Satisfactory operation of any steam heating system depends on adequate return of condensate to maintain steady water level.
 - b. Avoid adding excessive amounts of raw make-up water.
 - c. Where condensate return is not adequate, a low water cutoff with pump control, condensate receiver, and condensate boiler feed pump should be installed. Refer to page 18, Figure 18 for piping and Table 8 for sizing.
 3. Multiple steam boiler piping
 - a. See page 19.

Figure 14 Cold water fill piping

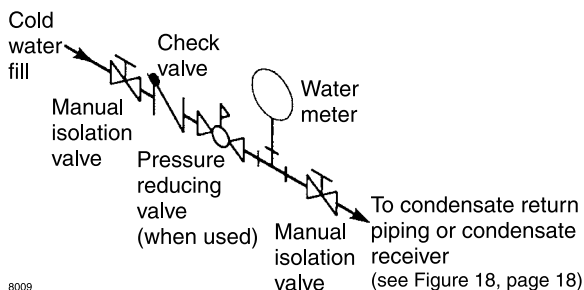

Table 7 Steam boiler pipe size for typical 2-pipe steam systems

Figure number	Boiler model number	Riser pipe size inches Note 1			"H" Header inches Note 2	"J" Equalizer inches
		A	B	C		
15	380	3	--	--	3	2
	480	4	--	--	4	2
	580	4	--	--	4	2 ½
16	680	3	3	--	4	2 ½
	780	4	4	--	4	2 ½
	880	4	4	--	4	3
	980	4	4	--	6	3
17	1080-1280	4	4	4	6	3

Notes:

1. Based on ASHRAE Handbook recommendations, allowing ½ oz. pressure drop per 100 feet of pipe for dry return.
2. Based on ASHRAE Handbook recommendations, allowing 2 oz. pressure drop per 100 feet of pipe at 3.5 psig. Maintain minimum 24" height from waterline to header.

8 Connect steam boiler piping (continued)

Figure 15 Model 380 through 580 steam boiler piping — NOTE minimum 24 inches between boiler water line and bottom of header.

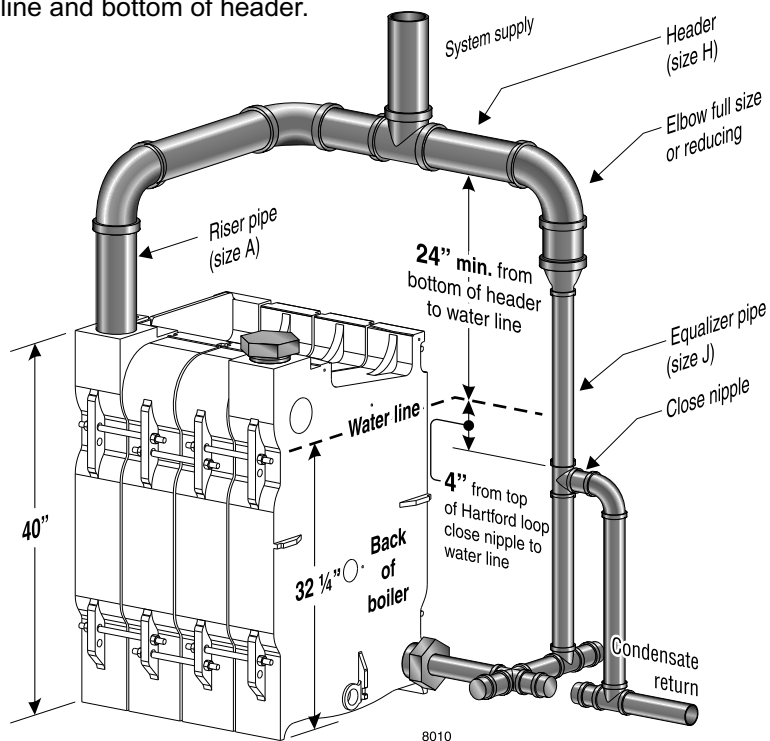
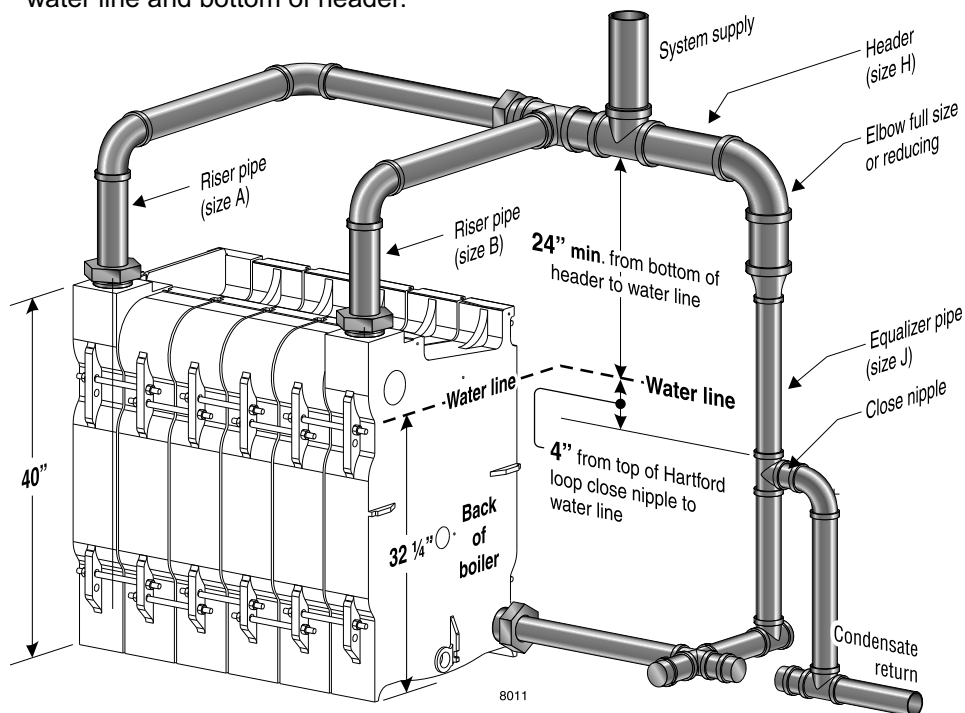

Figure 16 Model 680 through 980 steam boiler piping — NOTE minimum 24 inches between boiler water line and bottom of header.





8 Connect steam boiler piping (continued)

Figure 17 Model 1080 through 1280 steam boiler piping — NOTE minimum 24 inches between boiler water line and bottom of header.

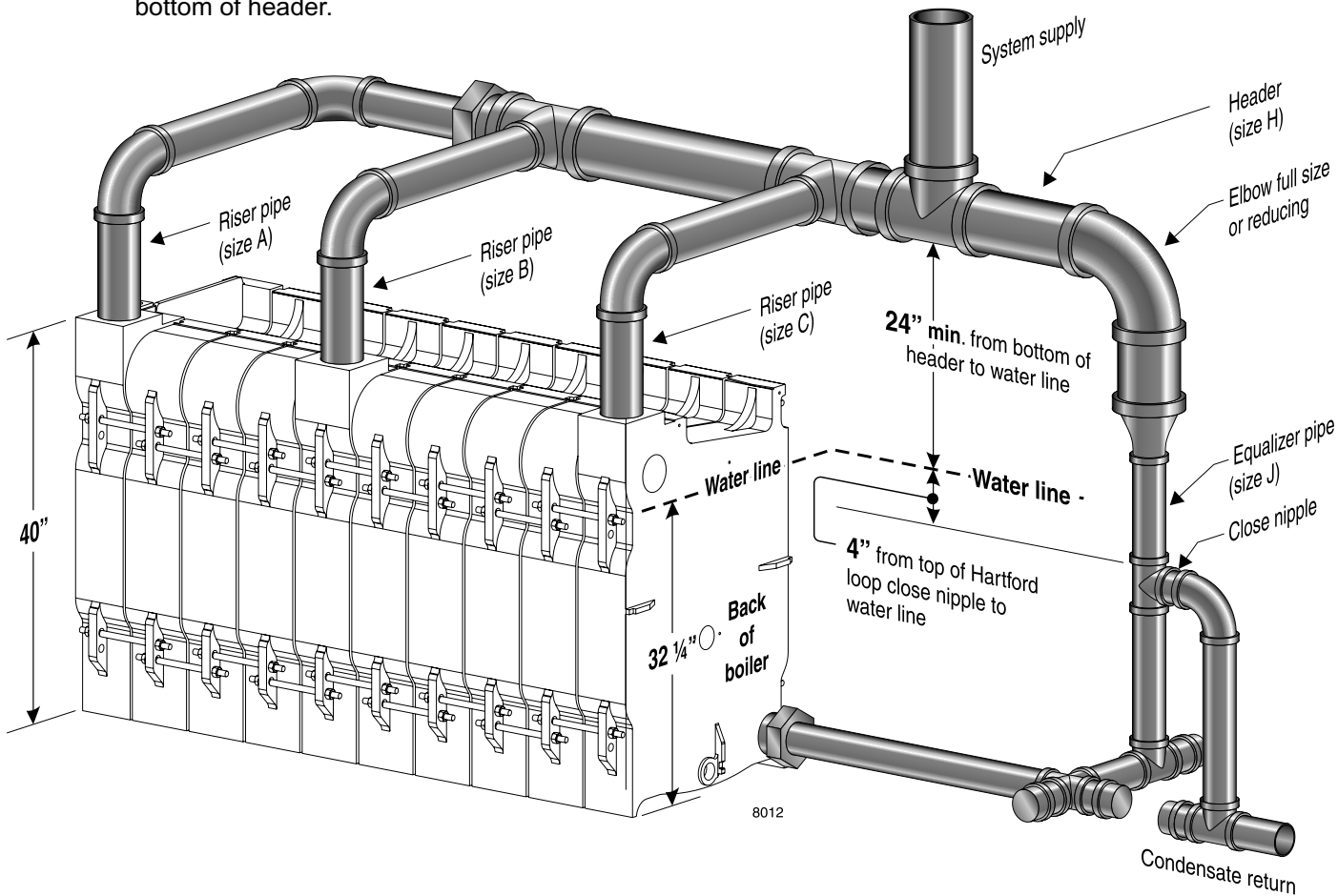

Figure 18 Condensate piping to boiler

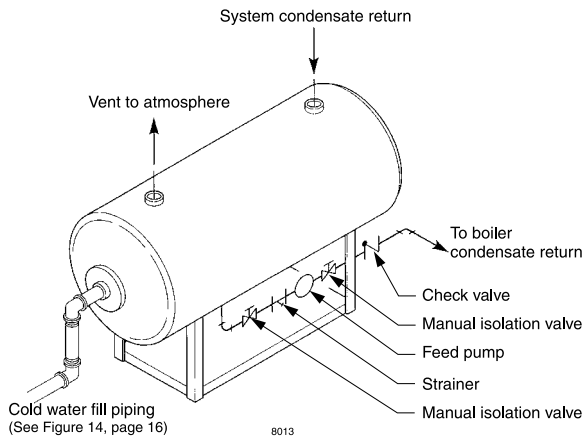

Table 8 Condensate receiver capacity

Boiler model number	AHRI gross output (lbs steam per hour)	Gallons condensate per hour	Minimum condensate receiver capacity (gallons) (Note 1)				Recommended condensate feed pump capacity GPM at 15 PSI
			15-minute boiler operation	30-minute boiler operation	45-minute boiler operation	60-minute boiler operation	
380	278	33	11	21	31	41	1.2
480	396	48	15	29	43	58	1.6
580	515	62	19	38	56	75	2.1
680	634	76	23	46	69	92	2.6
780	753	90	28	55	82	109	3.1
880	872	105	32	63	95	126	3.5
980	991	119	36	72	108	143	4.0
1080	1110	133	40	80	120	160	4.5
1180	1229	148	45	89	133	178	5.0
1280	1348	162	49	98	146	195	5.4

Note 1 — Maximum time to when condensate returns to boiler.

8 Connect steam boiler piping (continued)

Figure 19 Multiple Steam Boiler Piping Gravity Condensate Return

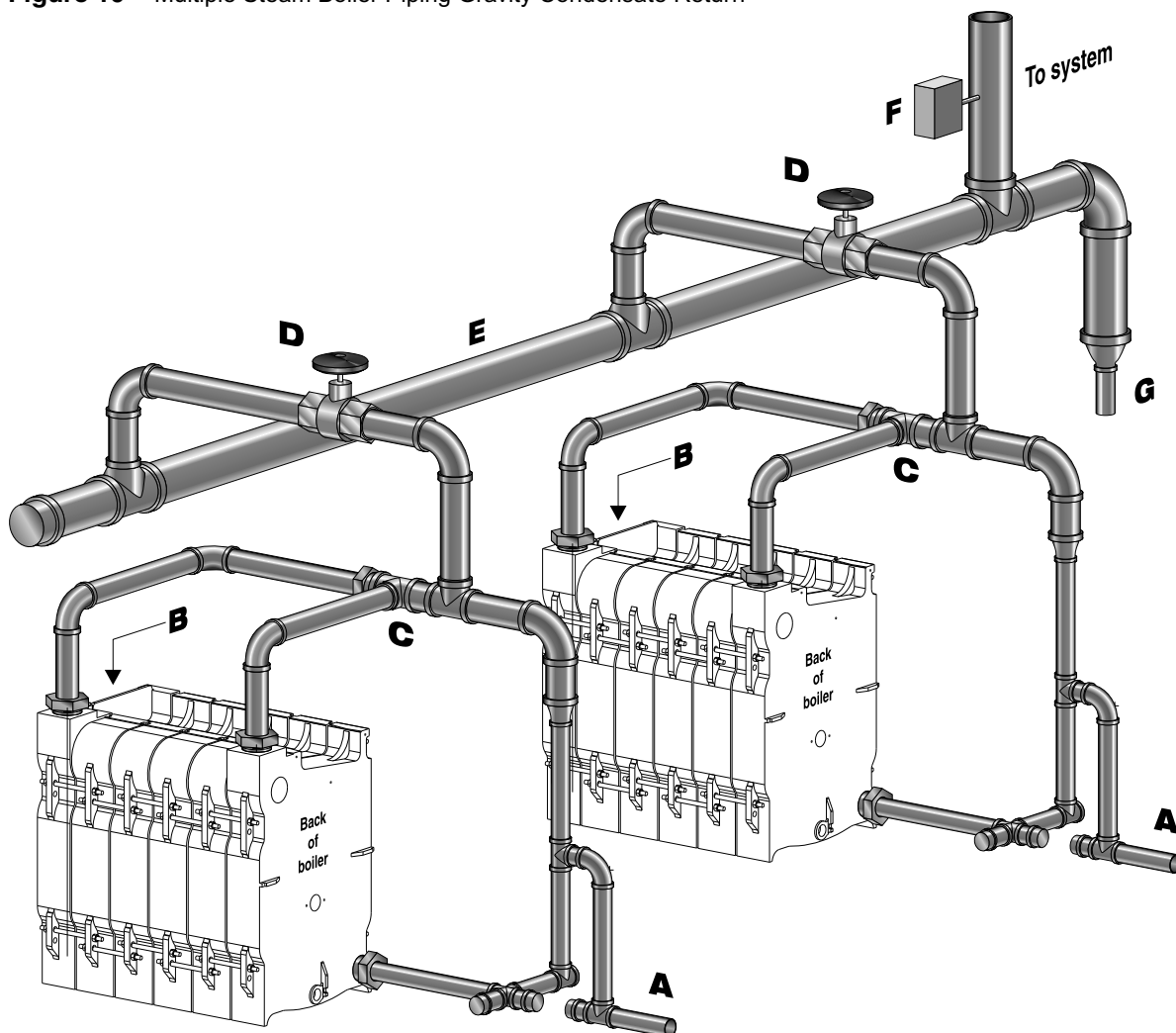

A Pipe as shown for gravity return systems, connecting point **A** to the wet gravity return.

For pumped-return systems, install boiler water level control on each boiler with body mark at level indicated in Figure 30 on page 30. Provide at point **A** either:

- Separate feed pumps and check valves for each boiler, or . . .
- Single feed pump, with separate solenoid valve for each boiler.

B For pumped-return systems, install a combination float and thermostatic trap on each boiler to prevent flooding of one boiler while other boiler is firing. Install trap in skim tapping (see page 29). Connect traps to condensate receiver.

Gravity-return systems are self-levelling if the wet returns are piped to the common system wet return.

C Install boiler piping as shown in this manual (pages 16 through 19).

D Install stop valves per ASME code requirements.

For pump-return systems, if using automatic steam valves, use only slow-opening automatic valves. Use a Weil-McLain Boiler Control System (such as a BCP panel) to open each steam valve automatically before firing burner.

E Construct common supply drop header with pipe size at least same size as largest boiler header size.

F Use:

- A Weil-McLain Boiler Control System (such as a BCP panel) with header-mounted pressure control(s) to sequence boilers, or . . .
- A steam pressure controller.

G Install drip line in common supply drop header.

Gravity-return: Pipe drip line to wet return.

Pumped-return: Use combination float and thermostatic trap and drain to condensate receiver.



9 Install jacket

Before installing jacket

1. Packaged boilers
 - Install top jacket panels per instructions in this manual.
2. Non-packaged boilers
 - Follow the instructions in this section to install all jacket panels.
 - Make sure the following are completed before installing jacket:
 - Boiler hydrostatically pressure-tested. See page 8.
 - Plugs for unused tappings installed. See control tapping table, page 28 or 29.
 - Supply and return piping installed. See pages 14 through 19.
 - Cleanout plates, flue collar and flue collector hood installed. See pages 9 through 13.
3. These parts must be on boiler:
 - plugs for unused tappings
 - supply and return piping
 - steam supply header
 - cleanout plates
 - tankless heater(s) (when used)
 - tankless heater cover plate(s) (when used)
 - tankless heater piping (when used)
 - flue damper assembly
 - flue collector hood
 - observation port assemblies
4. These parts may be on boiler:
 - burner mounting plate
 - burner
5. These parts must be off boiler:
 - water or steam gauge
 - limit control
 - low water cutoff
 - gauge glass and gauge glass cocks
 - tri-cocks
 - drain cock

WARNING

The boiler contains ceramic fiber and fiberglass materials. Use care when handling these materials per instructions on page 38 of this manual. Failure to comply could result in severe personal injury.

Remove jacket parts from cartons

1. Locate jacket cartons.
2. Remove jacket parts from cartons as needed. Leave in cartons as long as possible to avoid damage.

Install support brackets and rails

1. Place upper and lower support brackets over draw rods as shown in Figure 20, page 21.
 2. Fasten securely with $\frac{5}{8}$ " nuts where shown.
- NOTICE** Models 380, 480, 580, 680 and 780 do not require lower support brackets. Only upper brackets are required.
3. Space the brackets along the length of the boiler so there are close to an equal number of sections on either side of the bracket(s).
 4. Attach the upper and lower rails on each side of the boiler by securing with #10 x $\frac{1}{2}$ " Phillips pan head screws. **DO NOT** tighten the screws more than finger-tight.

Install jacket front and rear panels

1. Attach the front and rear jacket panels to the upper and lower channels using #10 x $\frac{1}{2}$ " Phillips pan head screws, as shown in Figure 20.
2. **Rear flue boilers only** — remove rear jacket panel flue collector transition knockout with tin snips before installing on boiler.



9 Install jacket (continued)

Figure 20 Installing jacket support brackets and rails and jacket front and rear panels

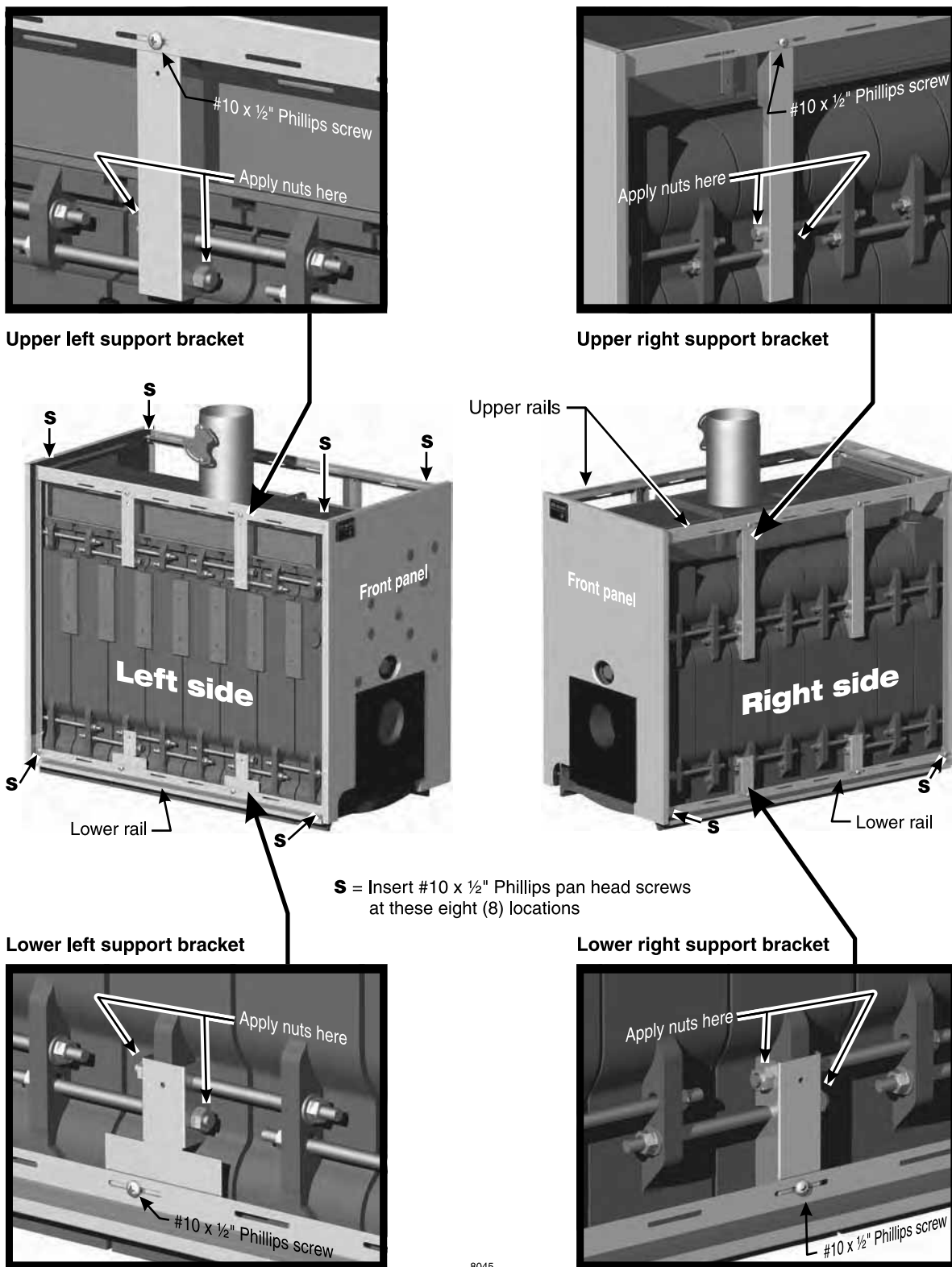

8045

9 Install jacket (continued)

Install jacket side panels

1. Remove jacket side panels from cartons.
2. Insert a plastic plug (provided in jacket cartons) in the 1-inch hole in the center of each of the jacket side panels.
3. Before installing side panels, square up the jacket support rails.
 - Place any of the jacket side panels on the rails as shown in Figure 21.
 - Butt the side panel against the jacket front panel.
 - Push/pull on the upper and lower rails until the fit-up of the side panel, front panel and rails is square.
 - Place a jacket top panel in position against the jacket front panel to ensure the top alignment is square. Adjust the jacket support rails forward or backward if needed for square alignment.
 - Tighten the screws securing the upper and lower rails to the support brackets.
 - Tighten the screws securing the front and back panels to the rails.
4. Apply all jacket side panels in the order shown in Figures 22, 23 or 24.
 - Remove jacket knockouts as required for tankless heaters.
 - Note that panel sequence is not important for boilers not equipped with tankless heater intermediate sections.

Install jacket top panels

1. Place jacket top panels as shown in Figure 25, page 26.
 - Remove knockouts for riser pipes or flue outlet using tin snips.
2. Fold out tab in top panel side flange next to top flue knockout to prevent top panel from sagging (see below).

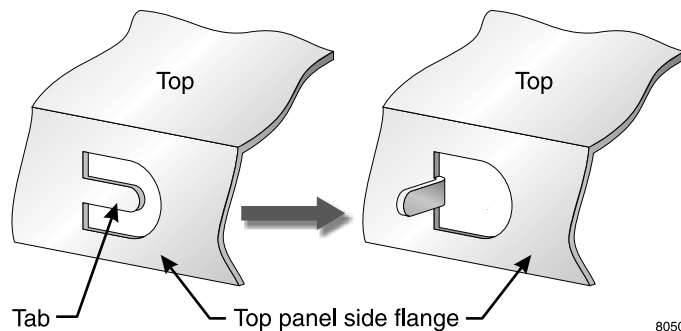

3. Install trim collar around damper assembly on top flue boilers.

Install jacket trim

1. Press jacket trim over jacket side panels as shown in Figure 21. Place each jacket trim so the side of the trim with small holes faces toward the boiler.

Figure 21 Installing (removing) jacket side panels and top panels

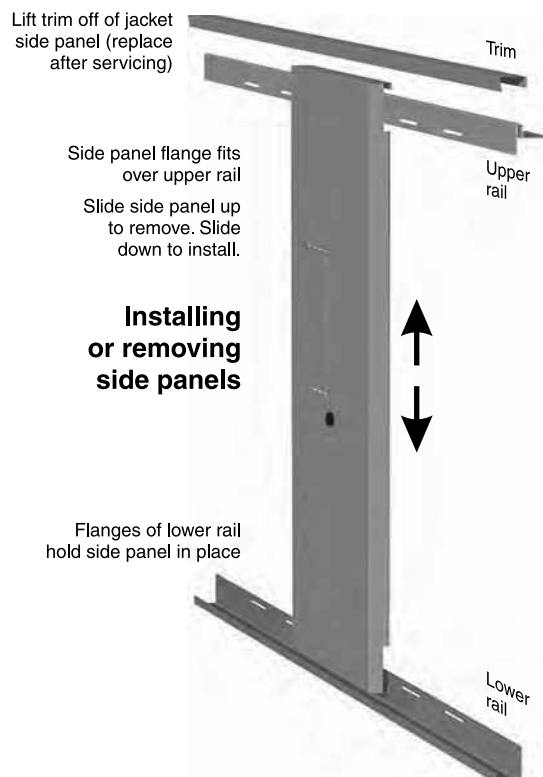
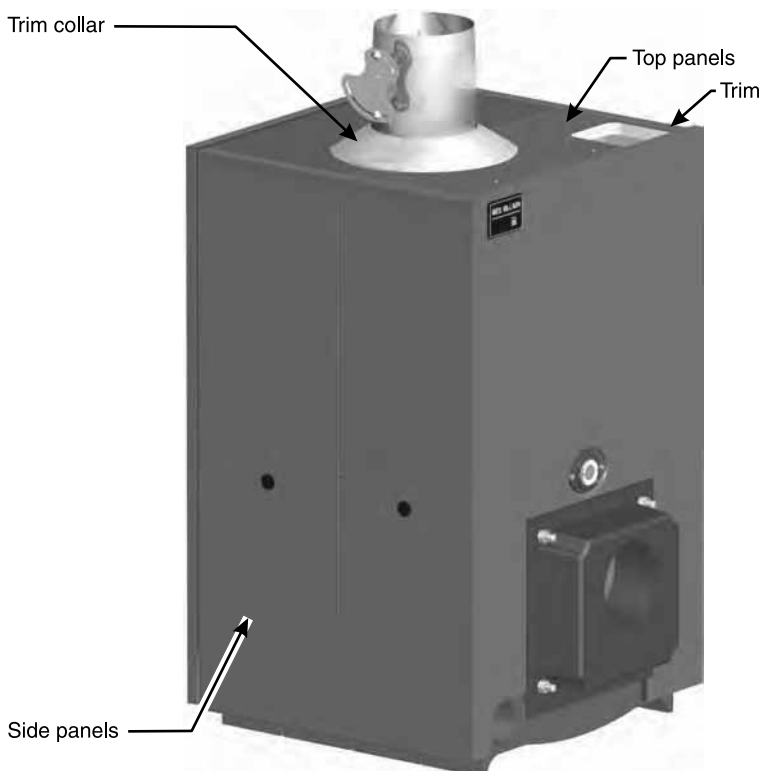

8046



9 Install jacket (continued)

Figure 22 Jacket side panel placement — Models 380, 480, 580 and 680

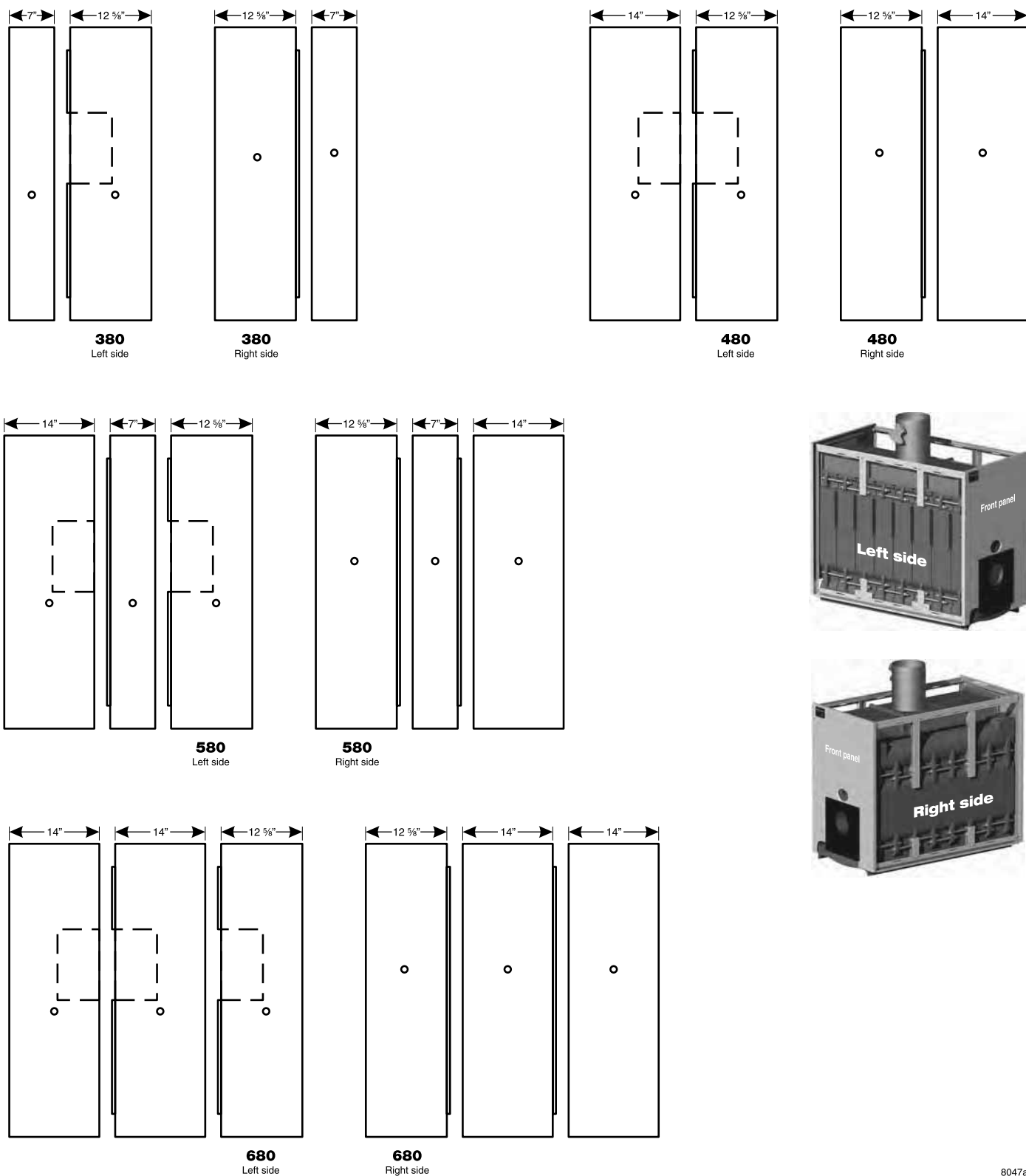

8047a



9 Install jacket (continued)

Figure 23 Jacket side panel placement — Models 780, 880 and 980

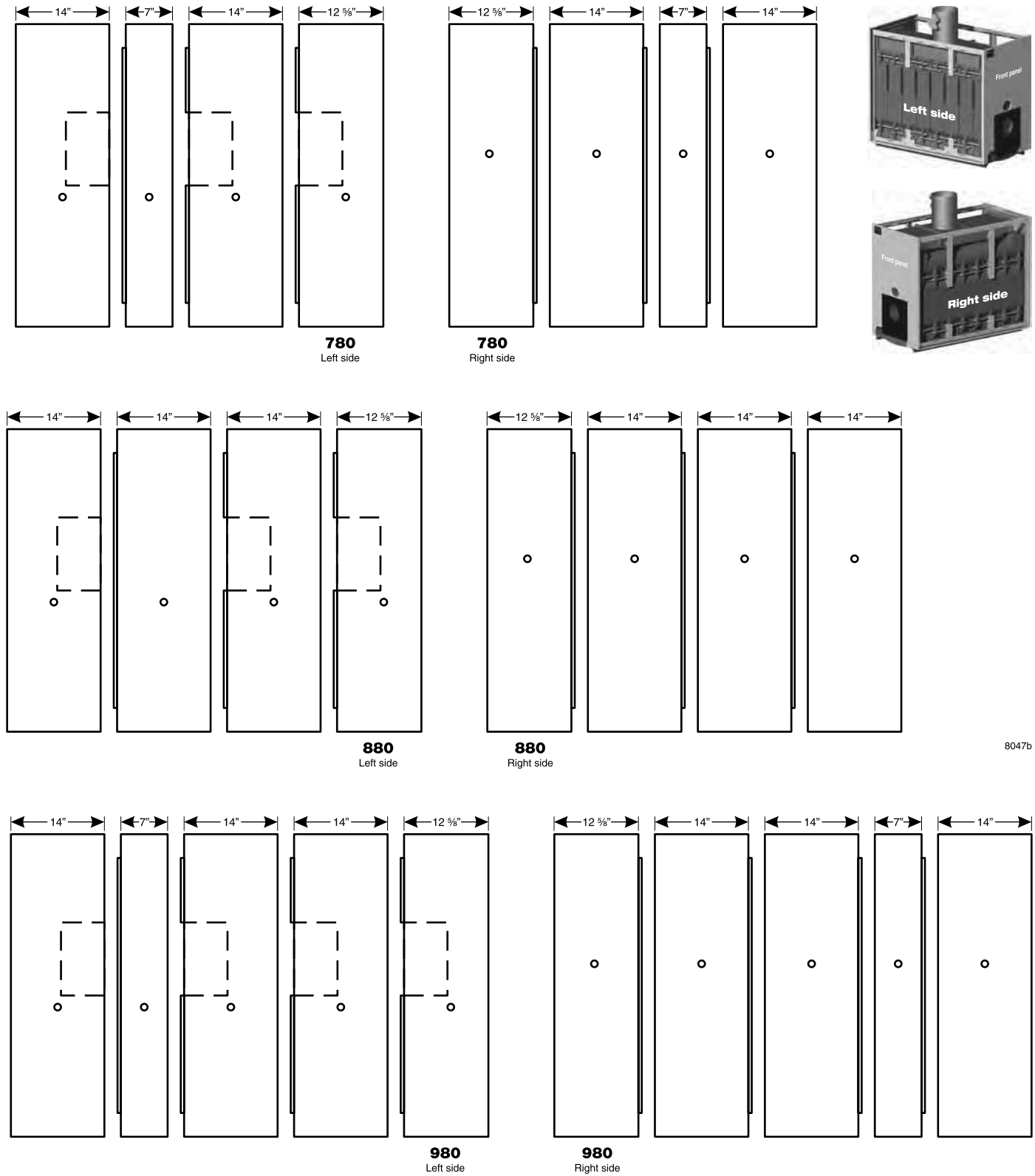

8047b



9 Install jacket (continued)

Figure 24 Jacket side panel placement — Models 1080, 1180, and 1280

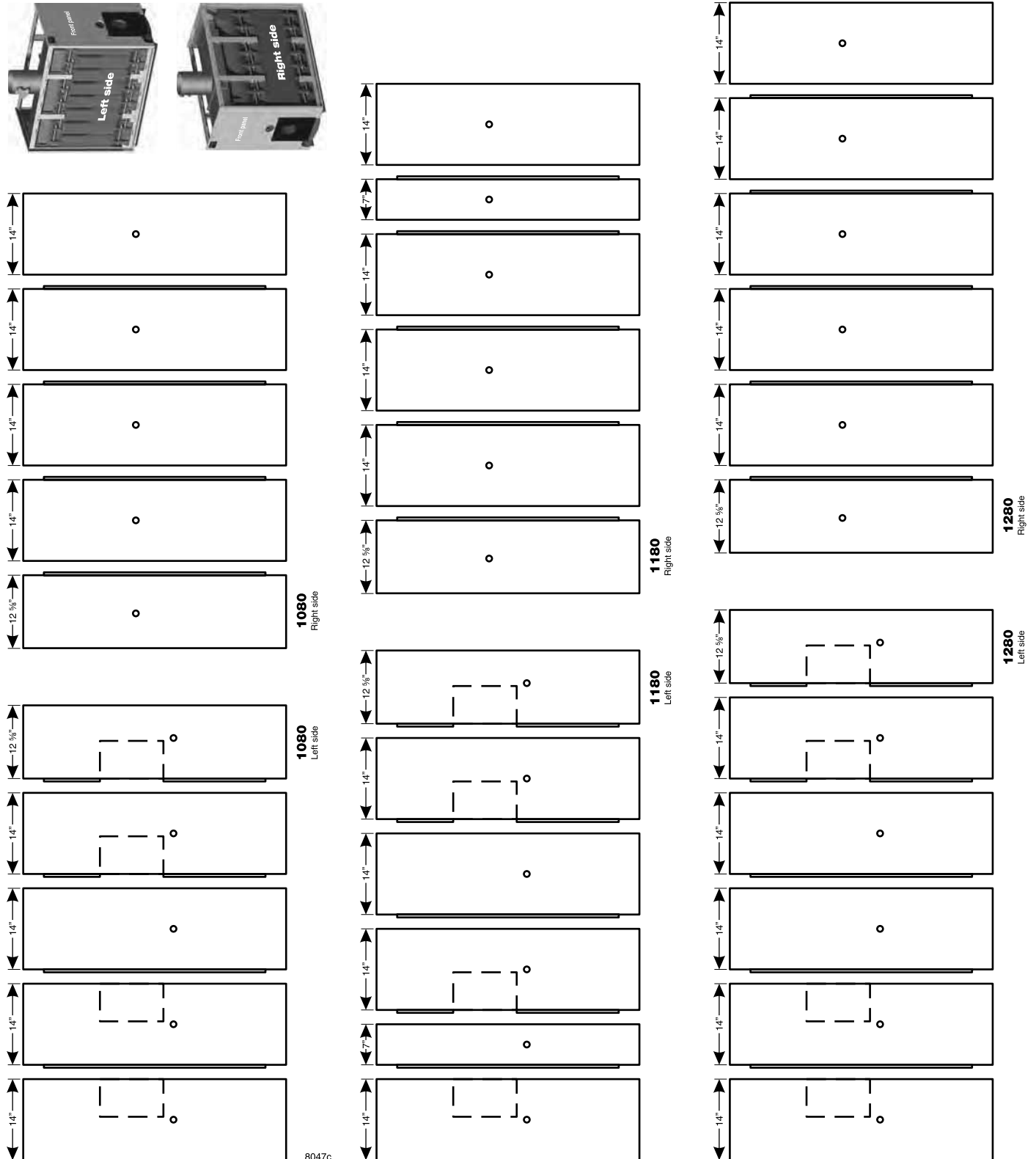

8047c



9 Install jacket (continued)

Figure 25 Jacket top panel placement

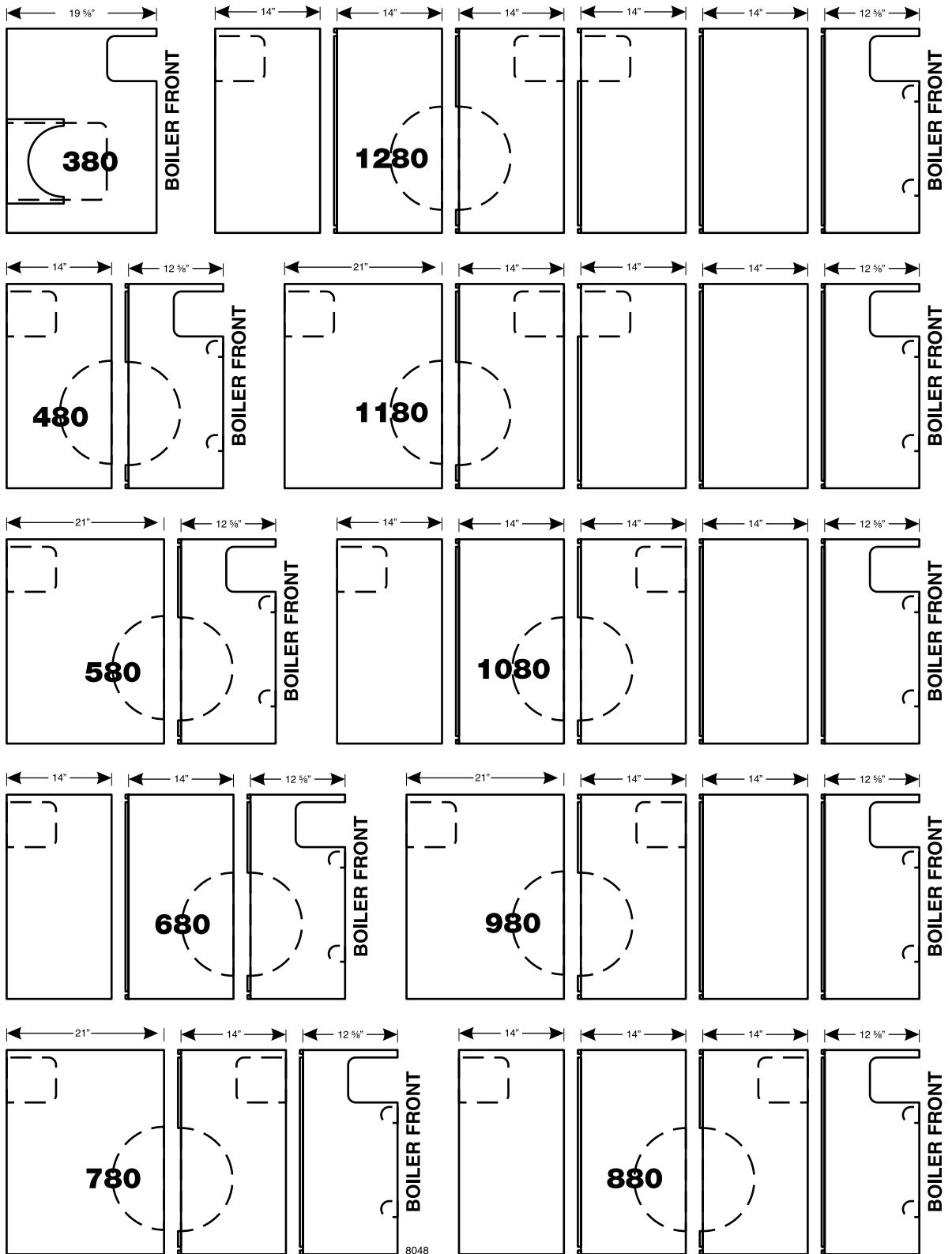

8048



10 Pipe tankless heaters

To pipe tankless heaters:

1. Size piping no smaller than heater inlet and outlet.
2. Automatic mixing valve must be installed. See Figure 26. Follow manufacturer's instructions to install.
3. Flow regulating valve must be installed. Size according to continuous draw of heater. See Table 9. Follow manufacturer's instructions to install.
4. Operating control with small adjustable differential scale is recommended. Install in temperature control tapping in heater plate.
5. Multiple tankless heaters (see Figure 26):
 - a. Use cold water supply header with individual risers to each heater. Size header by increasing one pipe size for each additional heater.
 - b. Use hot water outlet header with individual risers to each heater. Size header by increasing one pipe size for each additional heater.
 - c. Do not pipe multiple heaters in series.
6. In hard water areas, soften cold domestic water supply to heaters to prevent lime build-up.

Table 9 Tankless Heater Ratings

Tankless heater model	Continuous draw (no recovery period) GPM	Inlet and outlet tappings
78-24	6.5	3/4"

Figure 26 Tankless Heater Piping

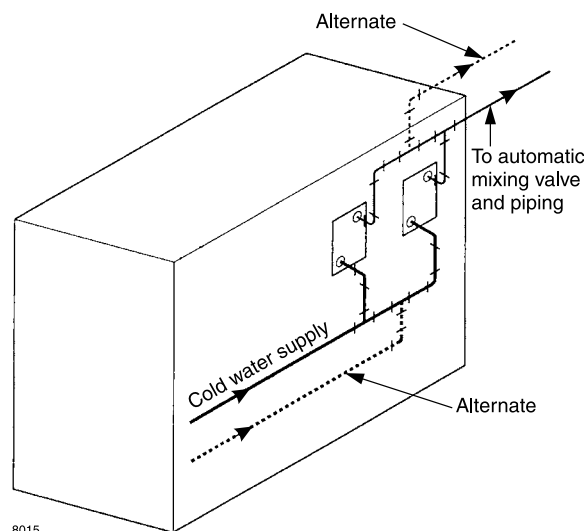

⚠ DANGER

Hot water can scald!

- Consumer Product Safety Commission and some states recommend domestic hot water temperature of 130°F or less.
- When installing an automatic mixing valve, selection and installation **must** comply with valve manufacturer's recommendations and instructions.
- Water heated to a temperature suitable for clothes washing, dish washing and other sanitizing needs will scald and cause injury.
- Children, elderly, infirm or physically handicapped persons are more likely to be injured by hot water. Never leave them unattended in or near a bathtub, shower or sink. Never allow small children to use a hot water faucet or draw their own bath. If anyone using hot water in the building fits this description, or if state laws or local codes require certain water temperatures at hot water faucets, take special precautions:
 - Install automatic mixing valve set according to those standards.
 - Use lowest practical temperature setting.
 - Check water temperature immediately after first heating cycle and after any adjustment.



11 Install water boiler controls

Install controls:

1. Install furnished controls where shown in Table 10 and Figure 27.

WARNING Failure to properly install, pipe and wire boiler controls can result in severe damage to boiler, building and personnel; and is not covered by boiler warranty.

2. Relief valve must be installed with spindle in vertical position. Use fittings provided with boiler. Do not make any other connection in that piping.

WARNING Relief valve discharge line must be piped using rigid material suitable for 375°F, threaded one end, near floor close to drain to eliminate potential of severe burns. Do not pipe to any area where freezing could occur. Do not plug, valve or place any obstruction in discharge line.

3. When installing low water cutoff
 a. Must be installed if boiler is located above radiation level.
 b. May be required on water boilers by certain state, local or territorial codes or insurance companies.
 c. Install low water cutoff designed for water installations where shown in Table 10 and Figure 27.

4. If installation is to comply with ASME installation requirements, an additional high temperature limit is needed. Purchase and install in supply line between boiler and isolation valve or in tapping "A."

5. Dual limit control settings:
 • **Low** – set according to design requirements.
 • **High** – at least 20° higher than low limit, 240°F maximum.

6. Install optional controls per control manufacturer's instructions.

Table 10 Water control tapings (see Figure 27)

Tapping	Size (NPT)	Water boilers, with water level controls:		
		Probe-type primary Probe-type secondary	Float-type primary Probe-type secondary	Float-type primary Float-type secondary
A	1½" Note 1	Combination high/low limit control		
B	3"	Water relief valve		
C1	1"	Firing rate control	Primary water level control	
C2	1"	Not used	Primary water level control	
D1	1"	Not used	Not used	Secondary level control
D2	1"	Not used	Not used	Secondary level control
E1	1"	Not used	Not used	Not used
E2	1"	Additional high/low limit control.		
F1	1"	Primary level control	Not used	
F2	1"	Not used	Firing rate control	
G	1"	Pressure-temperature gauge		
H	1½"	Boiler drain		
K	1"	Expansion tank piping or automatic air vent		
P	1"	Secondary level control		Not used

Notes: 1. 1½" plug provided with boiler. 2. By special request only.

Figure 27 Water control locations

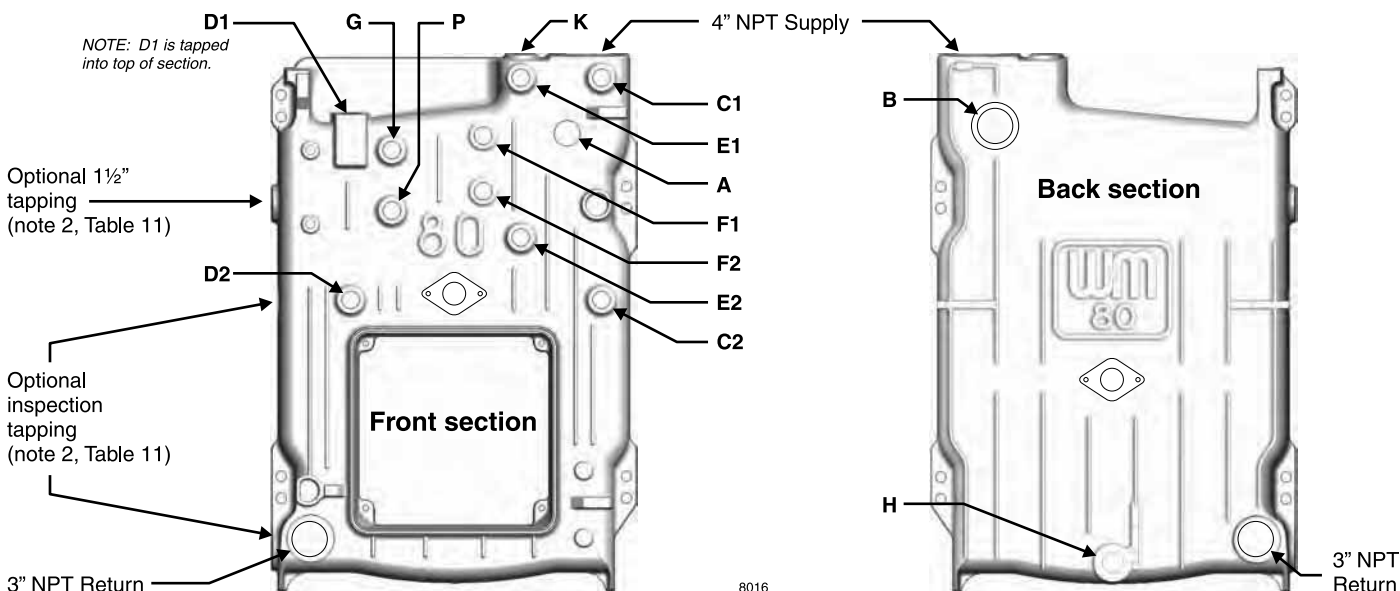



12 Install steam boiler controls

Install controls:

1. Install controls where shown in Table 11 and Figure 28.



Failure to properly install, pipe and wire boiler controls can result in severe damage to boiler, building and personnel; and is not covered by boiler warranty.

- a. Install steam pressure operating and high limit controls and pressure gauge. See Figure 28, this page, and Figure 29, page 30.
Pressure limit control settings:
 - **Low** – set according to design requirements.
 - **High** – set at least 2 psi higher than low limit, 15 psi maximum.
- b. Relief valve must be installed with spindle in vertical position. Use fittings provided with boiler. Do not make any other connection in that piping.



Pipe relief valve discharge through vertical piping to atmosphere. Use rigid material suitable for 375°F, threaded one end only. Install drain pan elbow to drain condensate. Pipe near floor close to floor drain to eliminate potential of severe burns. Do not pipe to any area where freezing could occur. Do not plug, valve or place any obstruction in discharge line.

- c. Install water level controls and gauge glass as shown in Figure 30 and Table 12, page 30.
 1. Fittings for controls to be furnished by others.
 2. If water level control is not shown in Table 12, page 30, locate casting mark on control and install per manufacturer's instructions.



Do not use water level controls with quick hook-up fittings. Nuisance shutdowns will occur.

Table 11 Steam control tappings (see Figure 28)

Tapping	Size (NPT)	Steam boilers, with water level controls:	
		Float-type primary Probe-type secondary	Float-type primary Float-type secondary
A	1½" Note 1	Skim tapping (Pipe skim piping to side of boiler.)	
B	3"	Steam relief valve	
C1	1"	Primary water level control	
C2	1"	Primary water level control	
D1	1"	Not used	Secondary level control
D2	1"	Not used	Secondary level control
E1	1"	Gauge glass	
E2	1"	Gauge glass	
F1	1"	Try cock tapping	
F2	1"	Try cock tapping	
G	1"	Control tree: Limit control, operating control, and pressure gauge	
H	1½"	Boiler drain	
K	1"	Not used	
P	1"	Secondary level control	Not used

Notes: 1. 1½" plug provided with boiler. 2. By special request only.

Figure 28 Steam control locations

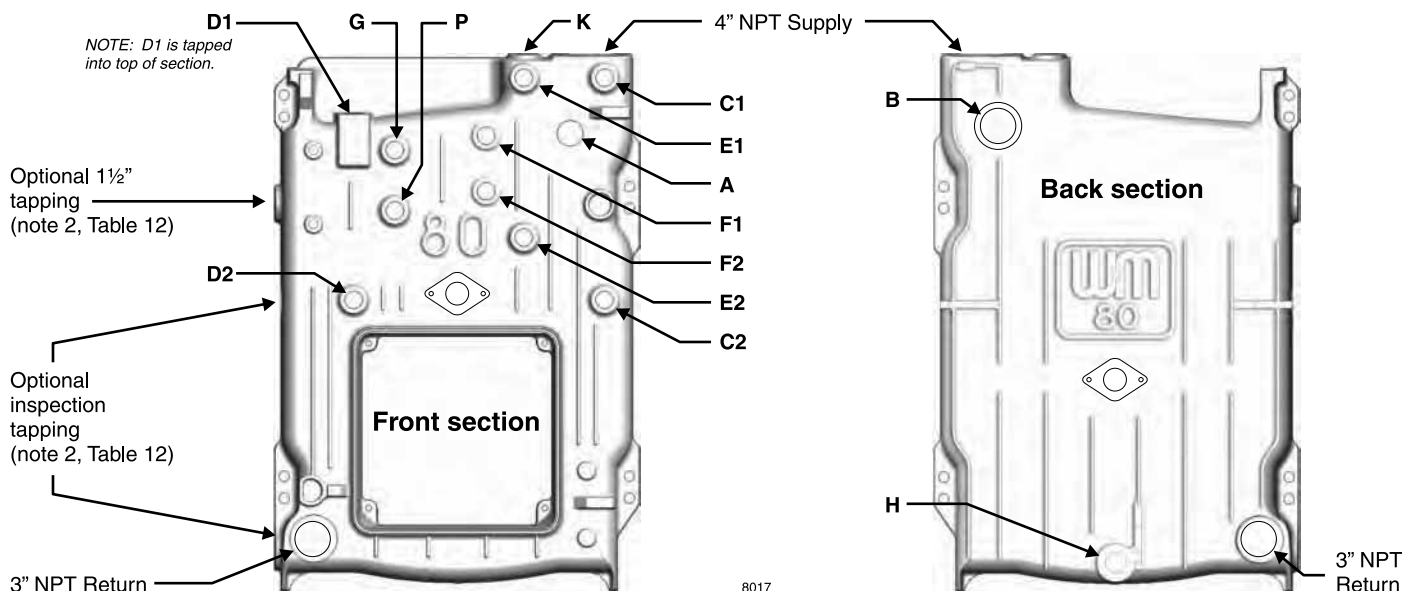



12 Install steam boiler controls (continued)

Figure 29 Steam control siphon and fittings

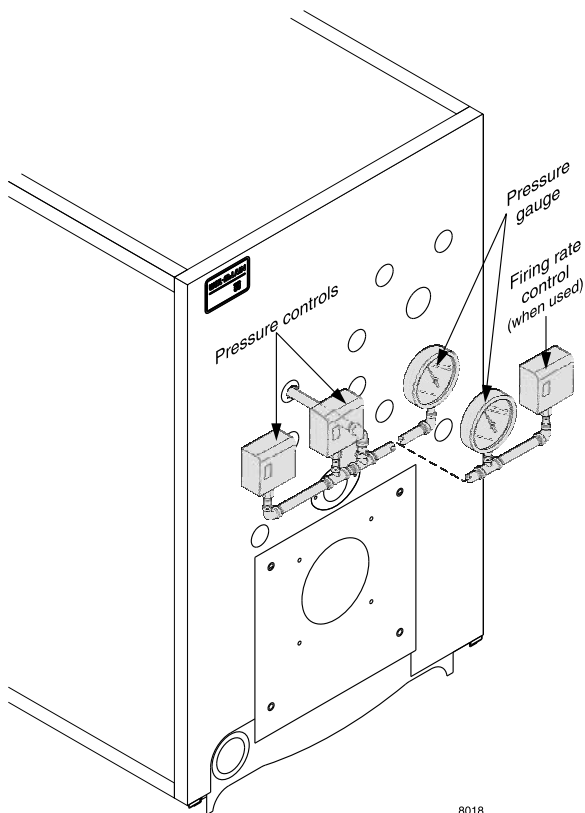

8018

Table 12 Water level control locations

Primary water level control	Casting line height above bottom of gauge glass	Back-up water level control	Casting line height above bottom of gauge glass	Back-up (only) probe-type water level control in "P" tapping
Note 1	"A"	Note 1	"B"	
61, 63	1½"	61, 63	½"	
42, 150MD, 157MD (see Notes 2 & 3)	2¾"	61, 63	½"	MM PS801-120
93, 193 (see Notes 2 & 3)	1¾"	61, 63	½"	or Hydrolevel 45-550
51-2 & 51-S-2 (see Notes 2 & 3)	2⅝"	61, 63	½"	

Notes:

- Other manufacturer's controls providing similar function may be used, if properly located and selected.
- Cannot be used as back-up water level controls.
- When pump control is used with feedwater tank, install pump control on boiler and make-up water feeder on tank. Use separate low water cutoff on boiler when back-up is needed. Do not install combination low water cutoff and feeder as back-up control on boiler. Feeder will operate before pump control operates.

Figure 30 Water level control locations (see Table 12)

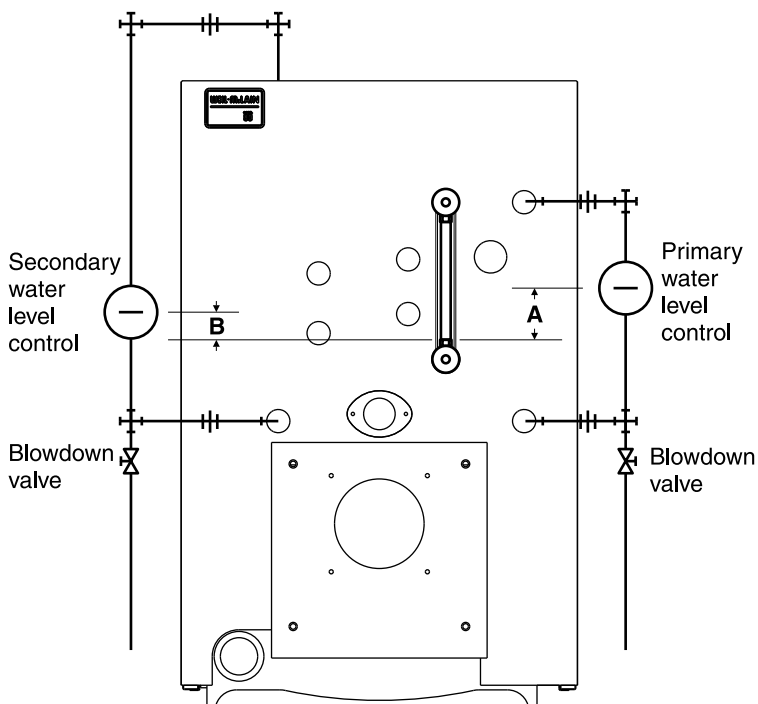

8019

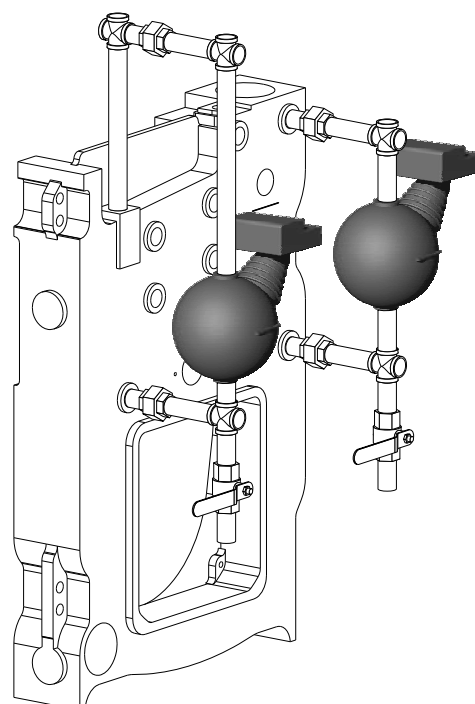



13 Connect breeching and venting systems

General venting information

- Model 80 boilers operate with positive overfire pressure. Adjust damper assembly (see page 33) during burner start-up to achieve 0.1" W.C. positive pressure at damper sample hole.

Select type of venting system

Forced draft

Boiler, breeching and stub vent operate at positive pressure. Entire system must be gas-tight to prevent leaks. Stub vent height must be limited to prevent negative draft with 3-foot minimum stub vent height above roof. See Figures 31 and 32.

Balanced draft

Boiler operates with positive pressure overfire. Chimney **may** provide excess draft which may require a barometric draft control installed and set to provide minimum draft to maintain 0.1" positive pressure at flue collar. Minimum chimney height above roof is 3 feet. See Figures 33 and 34.

Construct metal breeching:

- See Table 13 or Table 14 for minimum breeching diameter.
- Select material type and thickness in compliance with local codes.



Conventional flue pipe should not be used as it could leak flue gases and carbon monoxide emissions through seams and joints, resulting in severe personal injury or death.

- Refer to ASHRAE Guide for chimney and breeching calculations and construction and lining.



Long horizontal breechings, excessive number of tees and elbows or other obstructions restricting combustion gas flow can result in possibility of condensation, flue gas leakage and carbon monoxide emissions, causing severe personal injury or death.

Figure 31
Stub vent – forced draft — single boiler

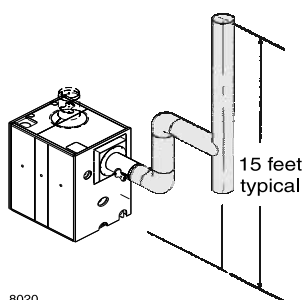

8020

Figure 32
Stub vent – forced draft — multiple boilers

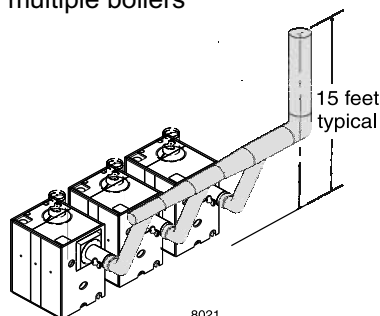

8021

Figure 33
Conventional chimney – balanced draft with barometric draft control when required — single boiler

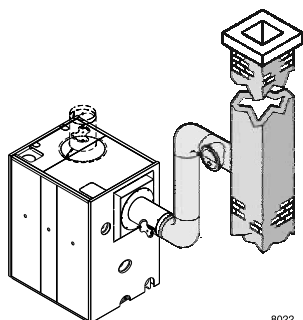

8022

Figure 34
Conventional chimney – balanced draft with barometric draft control when required — multiple boilers

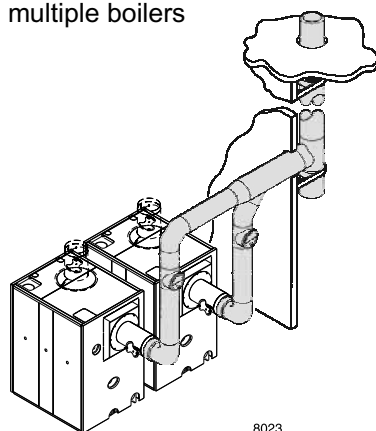

8023

Table 13 Minimum breeching diameter — forced draft venting

Boiler model number	AHRI recommended minimum vent diameter	Flue collar outlet diameter
	(inches)	(inches)
380	6	8
480	7	8
580	8	8
680	8	8
780	9	10
880	10	10
980	10	10
1080	10	10
1180	10	10
1280	12	12

Table 14 Minimum breeching diameter — balanced draft venting

Boiler model number	AHRI round vent diameter	AHRI rectangle chimney size	Minimum chimney/vent height	Flue collar outlet diameter
	(inches)	(inches)		
380	8	8 x 12	15	8
480	10	8 x 12	15	8
580	10	12 x 12	15	8
680	11	12 x 16	15	8
780	12	12 x 16	15	10
880	15	12 x 16	15	10
980	15	16 x 16	15	10
1080	15	16 x 16	15	10
1180	15	16 x 16	15	10
1280	15	20 x 16	15	12



14 Install burner

To install burner:

1. Unpack burner.
2. Place gasket around air tube and against burner mounting flange. If sealing rope is used, apply $\frac{1}{8}$ " continuous bead of rope adhesive around burner mounting flange and apply sealing rope to make gas-tight seal.
3. Mount burner into opening in burner mounting plate.



Maintain gas-tight seal between burner mounting flange and plate to prevent damage to air tube.

4. Level burner using burner support brackets where required.
5. Secure with furnished bolts.
6. Retain burner information packet. Keep with boiler.

15 Wiring and fuel piping



Electric shock hazard. Can cause severe personal injury or death if power source is not disconnected before installing or servicing boiler and burner.

To wire burner and boiler controls:

1. Install all wiring in compliance with:
 - National Electrical Code ANSI/NFPA 70.
 - Any additional national, state, or local codes.
2. Follow burner manual and wiring diagram found in burner information packet.
3. Use 14 ga. wire for operating and safety circuit wiring.
4. Where burner motor voltage differs from control voltage, supply proper voltage to each. Size fused disconnect(s) and conductors per National Electrical Code ANSI/NFPA 70.

To install gas and/or oil piping:

1. Install all piping in compliance with:
 - Local, state or national codes and regulations.
 - Separate burner manual provided with burner.
2. Use pipe joint compound (pipe dope) resistant to corrosive action of fuel oil or liquified petroleum gases. Apply sparingly to male threads of pipe joints. Do not use any kind of pipe tape.
3. Oil piping – use flare-type fittings, not compression type.



Do not use compression or soldered fittings. No safe repair can be made. Severe personal injury, death or substantial property damage will result.



Propane boilers — see WARNING on page 39 regarding propane gas odorant.

16 Make final adjustments

To fill water boilers:

1. Close manual air vents and drain cocks.
2. Fill to correct system pressure. Correct pressure will vary with each installation.
3. Starting on lowest floor, open air vents one at a time until water squirts out. Close vent. Repeat with remaining vents.
4. Refill boiler to correct pressure.

To fill steam boilers:

1. Do not fill (except for leakage test) until boiler is ready to be fired.
2. Fill to normal waterline, halfway up gauge glass.
3. Recommend boiler water pH 7.0 to 8.5.

Adjust burner and damper assembly:

1. Lock open flue transition damper.



Make final burner adjustments using combustion test equipment to assure proper operation. Do not fire boiler without water. Sections will overheat, damaging boiler and resulting in severe property damage.

2. Refer to burner manual for start-up and service.
3. Let burner advance to high fire. Heat boiler to design conditions.
4. Using combustion test equipment, adjust burner for:
 - a. 12% ($\pm \frac{1}{4}$ %) CO₂ for No. 2 fuel oil, 0 smoke.
 - b. 9 – 10% CO₂ natural gas; CO in flue gas not to exceed 50 ppm (0.01%).
5. Adjust damper assembly (Figure 35, page 33) to ensure 0.1" W.C. positive pressure at test opening. Tighten screws to secure in position. Plug test opening with 3/8" bolt provided with damper assembly.
6. Adjust barometric draft control, when used, to design conditions.
7. Repeat steps 4 through 6. Adjust as required.

16 Make final adjustments (continued)

Figure 35 Flue damper assembly, typical

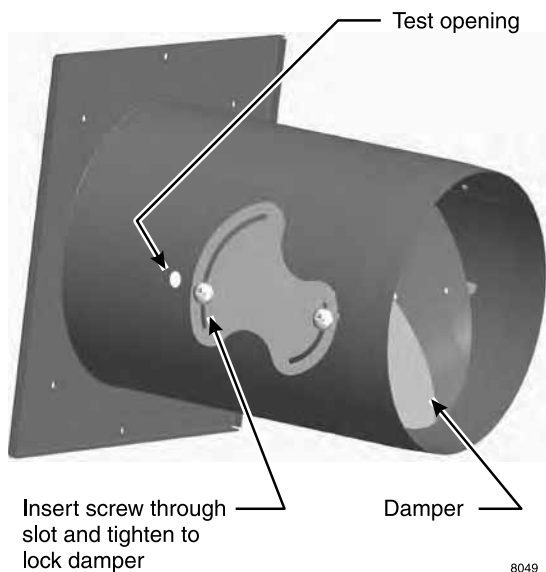

Skim steam boilers:

NOTICE

Clean all newly installed steam boilers to remove oil. Failure to properly clean can result in violent water level fluctuations, water passing into steam mains, or high maintenance costs on strainers, traps and vents. Skim boiler only. Do not clean old piping or leaks can occur.

WARNING

Do not use petroleum-based cleaning or sealing compounds in boiler system. Severe damage to system components can result, causing substantial property damage.

1. Remove 1½” plug from skim tapping tapping “A” – Figure 28, page 29). Provide 1½” skim piping from tapping to floor drain (pipe to side of boiler).
2. Raise waterline to midpoint of skim piping.
3. Fire burner to maintain temperature below steaming rate during skimming process.
4. Feed in water to maintain water level. Cycle burner to prevent rise in steam pressure.
5. Continue skimming until discharge is clear. This may take several hours.
6. Drain boiler. While boiler is warm **but not hot**, flush all interior surfaces under full pressure until drain water runs clear.
7. Remove skim piping. Re-insert plug at boiler skim tapping.
8. Close drain cock. Fill with fresh water to normal water line. Start burner and steam for 15 minutes to remove dissolved gases. Stop burner.
9. Check traps and air vents for proper operation.

Determine if water treatment is needed (water boilers only):

WARNING

Do not use petroleum-based cleaning or sealing compounds in boiler system. Severe damage to system components can result, causing substantial property damage.

Continual make-up water will reduce boiler life. Minerals can build up in sections, reducing heat transfer, overheating cast iron and causing section failure.

For unusually hard water areas or low pH conditions (less than 7.0) consult local water treatment company.

Freeze protection (when used):

1. Use antifreeze especially made for hydronic systems. Inhibited propylene glycol is recommended.

WARNING

Do not use automotive, ethylene glycol or undiluted antifreeze. Severe personal injury or death can result.

2. 50% solution provides protection to about -30°F.
3. Local codes may require back-flow preventer or actual disconnect from city water supply.
4. Determine quantity according to system water content. Boiler water content is listed on page 34. Percent of solution will affect sizing of heat distribution units, circulator and expansion tank.
5. Follow antifreeze manufacturer’s instructions.

Check boiler for gas-tight seal:

WARNING

Boiler must be sealed gas-tight to prevent possible flue gas leakage and carbon monoxide emissions, resulting in severe personal injury or death.

1. Remove boiler jacket side and top panels.

WARNING

The boiler contains ceramic fiber and fiberglass materials. Use care when handling these materials per instructions on page 38 of this manual. Failure to comply could result in severe personal injury.

2. Start burner. Observe all sealing points and chalk mark any not gas-tight.
3. To seal all chalk-marked areas:
 - a. use silicone sealant on section flueways.
 - b. check gaskets and sealing rope placement.
4. Reinstall all jacket panels.



17 Dimensions and ratings

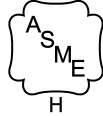

AHRI Certified Ratings

Boiler model number	AHRI burner capacity		Gross output MBH	Net AHRI ratings			Combustion efficiency		Thermal efficiency		Boiler H.P.	Net firebox volume Cu. ft.	Flue gas volume CFM	Flue outlet diameter Inches	Boiler water content (gallons)	
	Light oil GPH	Gas MBH		Steam Sq. Ft	Steam MBH	Water MBH	Oil	Gas	Oil	Gas					Water boiler	Steam to waterline
Notes: 1	2	3, 4	5, 6		5	5	%	%	%	%	—	—	7	—	—	—
380	2.40	346	278	867	209	242	85.3	82.7	82.7	80.2	8.3	2.61	139	8	37.5	27.5
480	3.40	491	396	1238	297	344	85.5	82.9	83.2	80.7	11.8	3.97	198	8	49.0	36.0
580	4.45	639	515	1608	386	448	85.1	82.6	83.1	80.6	15.4	5.33	259	8	60.5	44.5
680	5.50	787	634	1983	476	551	84.9	82.3	83.1	80.6	18.9	6.69	320	8	72.0	53.0
780	6.50	935	753	2354	565	655	84.7	82.2	83.1	80.6	22.5	8.05	378	10	83.5	61.5
880	7.50	1082	872	2725	654	758	84.6	82.0	83.0	80.6	26.0	9.41	436	10	95.0	70.0
980	8.50	1230	991	3096	743	862	84.5	82.0	83.0	80.5	29.6	10.77	494	10	106.5	78.5
1080	9.60	1378	1110	3471	833	965	84.4	81.9	83.0	80.5	33.2	12.13	558	10	118.0	87.0
1180	10.60	1526	1229	3842	922	1069	84.4	81.8	83.0	80.5	36.7	13.49	616	10	129.5	95.5
1280	11.60	1674	1348	4242	1018	1172	84.3	81.8	83.0	80.5	40.3	14.85	675	12	141.0	104.0

Boiler model number	Data				Dimensions (inches)							Packaged boiler weight (less water) Lbs	Packaged boiler weight (with water) Lbs
	Supply tapplings Qty-size (see Note)		Return tapplings Qty-size (see Note)		A	B	D	F	H	W	L		
	Water	Steam	Water	Steam									
380	2 - 4"	2 - 4"	2 - 3"	2 - 3"	13 1/8	--	8	12 7/16	13 1/2	20 3/8	21 5/8	1058	1170
480	2 - 4"	2 - 4"	2 - 3"	2 - 3"	20 1/8	--	8	13 5/8	20 1/2	27 3/8	28 5/8	1203	1411
580	2 - 4"	2 - 4"	2 - 3"	2 - 3"	27 1/8	--	8	13 5/8	27 1/2	34 3/8	35 5/8	1448	1752
680	2 - 4"	2 - 4"	2 - 3"	2 - 3"	34 1/8	--	8	13 5/8	34 1/2	41 3/8	42 5/8	1843	2093
780	2 - 4"	2 - 4"	2 - 3"	2 - 3"	41 1/8	--	10	27 5/8	41 1/2	48 3/8	49 5/8	2088	2434
880	2 - 4"	2 - 4"	2 - 3"	2 - 3"	48 1/8	--	10	27 5/8	48 1/2	55 3/8	56 5/8	2317	2774
980	2 - 4"	2 - 4"	2 - 3"	2 - 3"	55 1/8	--	10	41 5/8	55 1/2	62 3/8	63 5/8	2678	3115
1080	2 - 4"	3 - 4"	2 - 3"	2 - 3"	62 1/8	27 9/16	10	41 5/8	62 1/2	69 3/8	70 5/8	2923	3456
1180	2 - 4"	3 - 4"	2 - 3"	2 - 3"	69 1/8	34 9/16	10	55 5/8	69 1/2	76 3/8	77 5/8	3068	3697
1280	2 - 4"	3 - 4"	2 - 3"	2 - 3"	76 1/8	34 9/16	12	55 5/8	76 1/2	83 3/8	84 5/8	3313	4038

NOTE: Use piping connections shown in manual pages 14 through 19.

Notes

1. Burner input based on maximum of 2,000 feet altitude. For higher altitudes consult local Weil-McLain representative.
2. No. 2 fuel oil Commercial Standard Spec. CS75-56. Heat value of oil — 140,000 Btu/Gal.
3. Consult Weil-McLain Burner Specifications and Data Sheet for gas pressures required.
4. MBH refers to thousands of Btu per hour.
5. Gross AHRI ratings have been determined under the AHRI provision forced draft boiler-burner units.
6. Net AHRI ratings are based on net installed radiation of sufficient quantity for the requirements of the building and nothing need be added for normal piping and pickup. Water ratings are based on a piping and pickup allowance of 1.15. Steam ratings are based on the following allowances: 380 thru 1180 — 1.333; 1280 — 1.321. An additional allowance should be made for gravity hot water systems or for unusual piping and pickup loads. Consult local Weil-McLain representative.
7. Stack gas volume at outlet temperature.
8. With 0.10" W.C. positive pressure at flue collar.

NOTICE: Boiler sections are tested for 80 PSIG working pressure. Water boilers are supplied with 30 PSIG relief valve standard.



17 Dimensions and ratings (continued)

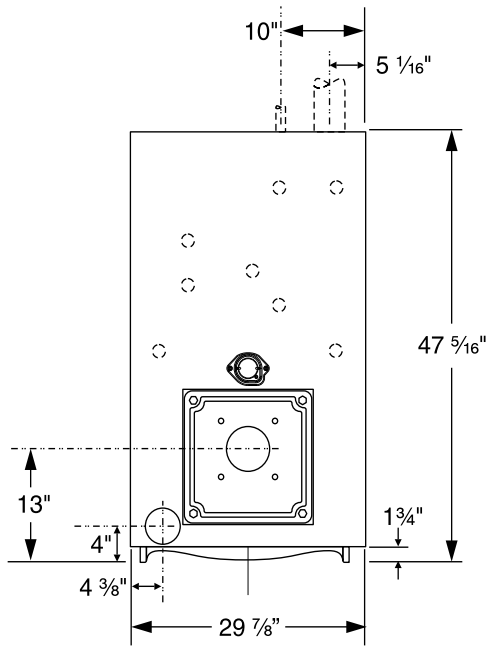

FRONT

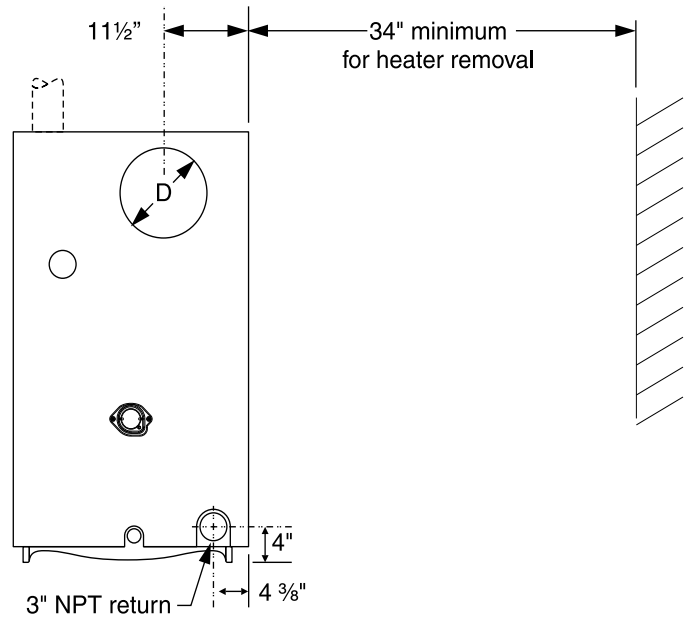

BACK

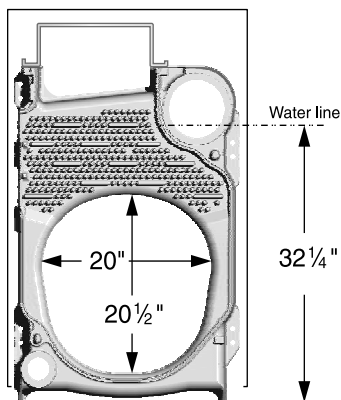

INTERMEDIATE

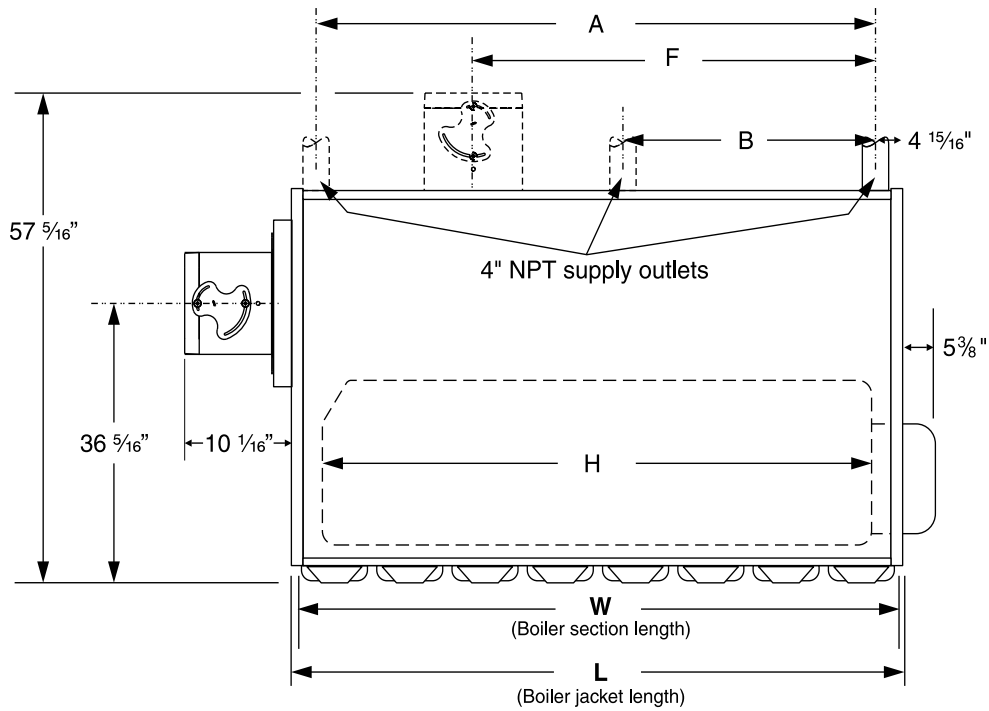

SIDE

8026



18 Parts

Item number	Description	Weil-McLain part number
1	Front section	315-700-100
2	Intermediate section, regular Intermediate section with special side tapings Intermediate section, supply (steam boilers)	315-700-120 315-700-130 315-700-150
3	Intermediate section, tankless	315-700-140
4	Back section	315-700-110
not shown	Section assembly kit (includes for one joint: sealing rope, sealing rope adhesive, sealing rings, silicone sealant)	385-800-205
5	Heater cover plate carton (includes: cover plate, gasket, studs, nuts)	385-700-200
6	Tankless heater carton (includes tankless heater, gasket, studs, nuts)	590-921-917
7	Heater gasket	590-317-550
8	Cleanout plate	450-030-928
9	Cleanout plate gasket	590-317-303
10	Burner mounting plate, front refractory 4½" burner opening 6½" burner opening	591-000-070 591-000-072
11	Refractory retainer clip	562-650-105
12	Observation port assembly (includes: observation port assembly, sealing rope, screws)	385-600-099
13	Sealing rope	590-735-140
not shown	Combustion chamber kit (includes: back refractory blanket, bottom refractory blanket, adhesive, sealing rope, sealing rope adhesive)	385-700-220
14	Flue damper assembly, top flue boilers 8" 10" 12"	425-800-090 425-800-091 425-800-092
14a	Flue damper assembly, rear flue boilers 8" 10" 12"	425-800-096 425-800-097 425-800-098
not shown	Flue collector hood hardware kit (includes: flue collector hardware plus collector hood gasket kit, below)	385-800-215
15	Flue collector hood end cap	463-000-003
Not shown	Collector hood gasket kit (includes: (2) flue collector hood gasket, (3) circular collector hood gaskets, (1) rectangular collector hood gasket, flat-stitched sealing rope, double-faced tape)	385-800-218
16	Flue collector hood gasket	Included in gasket kit
17	Flue collector hoods	450-020-300 450-020-301 450-020-302 450-020-303 450-020-304
18	Flue cap	Included with flue damper assembly
19	Flue cap rear	
20	Rear flue transition box	
21	Circular collector hood gasket	Included in gasket kit
22	Rectangular collector hood gasket	Included in gasket kit



18 Parts (continued)

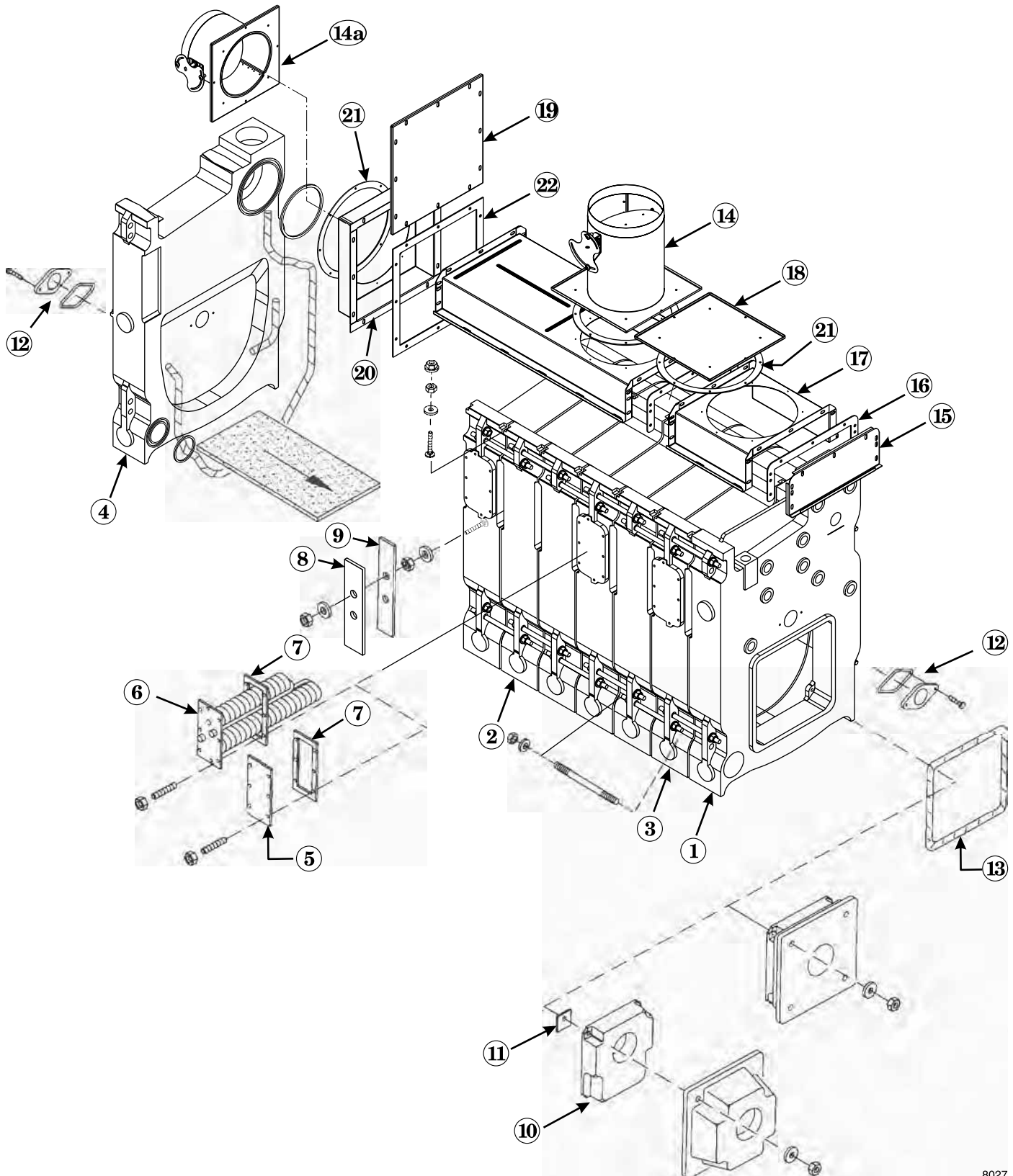

8027



Handling ceramic fiber and fiberglass materials

⚠ WARNING

This symbol is used in this addendum to indicate presence of hazards that can cause severe personal injury, death or substantial property damage.

REMOVAL OF COMBUSTION CHAMBER LINING OR BASE PANELS

⚠ WARNING

The combustion chamber lining or base insulation panels in this product contain ceramic fiber materials. Ceramic fibers can be converted to cristobalite in very high temperature applications. The International Agency for Research on Cancer (IARC) has concluded, "Crystalline silica inhaled in the form of quartz or cristobalite from occupational sources is carcinogenic to humans (Group 1).":

- Avoid breathing dust and contact with skin and eyes.
 - Use NIOSH certified dust respirator (N95). This type of respirator is based on the OSHA requirements for cristobalite at the time this document was written. Other types of respirators may be needed depending on the job site conditions. Current NIOSH recommendations can be found on the NIOSH web site at <http://www.cdc.gov/niosh/homepage.html>. NIOSH approved respirators, manufacturers, and phone numbers are also listed on this web site.
 - Wear long-sleeved, loose fitting clothing, gloves, and eye protection.
- Apply enough water to the combustion chamber lining or base insulation to prevent airborne dust.
- Remove combustion chamber lining or base insulation from the boiler and place it in a plastic bag for disposal.
- Wash potentially contaminated clothes separately from other clothing. Rinse clothes washer thoroughly.

NIOSH stated First Aid.

- Eye: Irrigate immediately
- Breathing: Fresh air.

REMOVAL OF FIBERGLASS WOOL — OR —

INSTALLATION OF FIBERGLASS WOOL, COMBUSTION CHAMBER LINING OR BASE PANELS:

⚠ WARNING

This product contains fiberglass jacket insulation and ceramic fiber materials in combustion chamber lining or base panels in gas fired products. Airborne fibers from these materials have been listed by the State of California as a possible cause of cancer through inhalation.

- Avoid breathing dust and contact with skin and eyes.
 - Use NIOSH certified dust respirator (N95). This type of respirator is based on the OSHA requirements for fiberglass wool at the time this document was written. Other types of respirators may be needed depending on the job site conditions. Current NIOSH recommendations can be found on the NIOSH web site at <http://www.cdc.gov/niosh/homepage.html>. NIOSH approved respirators, manufacturers, and phone numbers are also listed on this web site.
 - Wear long-sleeved, loose fitting clothing, gloves, and eye protection.
- Operations such as sawing, blowing, tear out, and spraying may generate airborne fiber concentration requiring additional protection.
- Wash potentially contaminated clothes separately from other clothing. Rinse clothes washer thoroughly.

NIOSH stated First Aid.

- Eye: Irrigate immediately
- Breathing: Fresh air.



Propane boilers — propane gas odorant

▲ WARNING

Propane boilers only — Your propane supplier mixes an odorant with the propane to make its presence detectable. In some instances, the odorant can fade and the gas may no longer have an odor.

- Propane gas can accumulate at floor level. Smell near the floor for the gas odorant or any unusual odor. If you suspect a leak, do not attempt to light the burner.
- Use caution when attempting to light a propane burner (or pilot burner). This should be done by a qualified service technician, particularly if flame outages (or pilot outages) are common.
- Periodically check the odorant level of your gas.
- Inspect boiler and system at least yearly to make sure all gas piping is leak-tight.
- Consult your propane supplier regarding installation of a gas leak detector. There are some products on the market intended for this purpose. Your supplier may be able to suggest an appropriate device.



Weil-McLain
500 Blaine Street
Michigan City, IN 46360-2388
<http://www.weil-mclain.com>



80 Water & steam boilers

for use with Gas, Light Oil, & Gas/Light Oil – Fired Burners

Burner specifications and data

Carlin burners

Models **EZ-3HPW, 201CRD-W, 301CRD-W, 702CRD-W** and **801CRD-W** *Flame retention type, for light oil firing*

Model EZ-3HPW

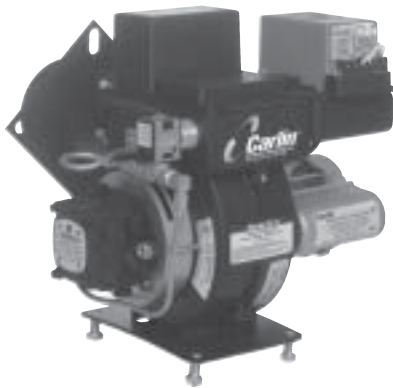

Models 201CRD-W and 301CRD-W



Models 702CRD-W and 801CRD-W

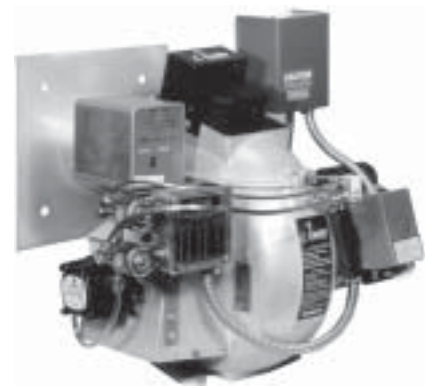

Burner Model Number	Motor Size H.P. (3450 RPM)	Standard motor Electrical Characteristics	Optional Motor Electrical Characteristics	Approximate Shipping Weight (lbs)
EZ-3HPW	1/7	120/60/0	240/60/0	45
201CRD-W	1/4	120/60/1	240/60/1	58
301CRD-W	1/4	120/60/1	240/60/1	58
702CRD-W	1/2	120/60/1	240/60/1	75
801CRD-W	3/4	240/60/1	208-240/60/3	90



Boiler model number	Burner Input (forced draft) No. 2 oil	Low fire firing rate No. 2 oil	Positive pressure in firebox	Standard burner model designation	Standard combustion control	Air band setting	Starting head setting	Approximate air settings
	GPH	GPH	Inches W.C.					Low fire
380	2.40	--	0.28	EZ-3HP-W	60200	2.50	2.50	--
480	3.40	--	0.28	201CRD-W	60200	60%	7/16	--
580	4.45	--	0.28	301CRD-W	60200	50%	7/16	--
680	5.50	--	0.27	301CRD-W	60200	100%	1/2	--
780	6.50	3.75	0.27	702CRD-W	60200	--	1/8	5/16
880	7.50	4.50	0.27	702CRD-W	60200	--	1/4	5/16
980	8.50	5.00	0.27	702CRD-W	60200	--	3/8	3/8
1080	9.60	5.50	0.26	702CRD-W	60200	--	9/16	3/8
1180	10.60	6.00	0.26	702CRD-W	60200	--	3/4	3/8
1280	11.60	5.50	0.26	801CRD-W	60200	--	1/4	1/8

Notes

- 1 Burner capacities listed for elevations up to 2,000 feet. For higher elevations, consult local Weil-McLain distributor/agent or sales office.
- 2 Oil ratings based on No. 2 fuel oil with heating value of 140,000 Btu per gallon.
- 3 Boiler-burner unit to be adjusted to achieve + 0.1 inches W.C. pressure at flue collar, resulting in positive pressure in firebox as listed.
- 4 60200 combustion safety control uses a cadmium sulfide cell flame detector to monitor oil flame, provides interrupted duty, recycle type operation, latch-up feature, 30-second oil valve delay on, 30-second post purge, alarm contacts and safety monitor circuit.

Burner Specification and Data Sheet



Boiler model number	Oil nozzle (one per unit)								Operating oil pressure(s) PSIG		Fuel unit Burner-motor driven 3450 RPM	
	Primary nozzle				Alternate nozzle						Type (Suntec)	Gearset capacity GPH
	Size GPH	Brand	Type	Angle	Size GPH	Brand	Type	Angle	Low fire	High fire		
380	2.00	Delavan	A	45°	2.00	Hago	H	45°	--	150	A2VA-3006	17
480	2.75	Hago	P	60°	2.75	Danfoss	AS	60°	--	150	B2YA-8916	25
580	3.75	Hago	P	60°	4.00	Delavan	B	70°	--	150	B2YA-8916	25
680	4.50	Hago	P	60°	4.50	Delavan	B	70°	--	150	B2YA-8916	25
780	3.75	Hago	P	45°	4.00	Delavan	B	60°	100	300	B2TA-8851-4	33
880	4.50	Hago	P	45°	4.50	Delavan	B	60°	100	300	B2TA-8851-4	33
980	5.00	Hago	P	45°	5.00	Delavan	B	60°	100	300	B2TA-8851-4	33
1080	5.50	Hago	P	45°	5.50	Delavan	B	60°	100	300	B2TA-8851-4	33
1180	6.00	Hago	P	45°	6.00	Delavan	B	60°	100	300	B2TA-8851-4	33
1280	5.50 (Low Fire-Top Nozzle) 4.00 (High Fire-Bottom Nozzle)	Hago	P	45°	5.50 (Low Fire-Top Nozzle) 4.00 (High Fire-Bottom Nozzle)	Delavan	B	45°	150	150	B2TA-8260	39

Notes

- 5 All motors furnished with integral overload protection with manual reset.
- 6 EZ-3HP-W, 201CRD-W and 301CRD-W burners are furnished for on-off operation only. 702CRD-W and 801CRD-W burners are furnished with mechanical pressure atomizing oil control system with on-off operation, low fire start, high fire run and two-position air control as standard. Low-high-low fire operation can be obtained by addition of SPST temperature or pressure controller.
- 7 Settings shown are for initial start-up. Final settings should be determined after combustion readings.
- 8 120/60/1 control circuit is used for all burners.



Dimensions — EZ-3HPW

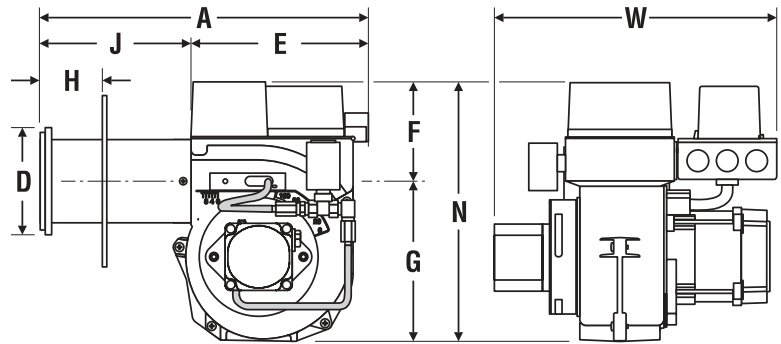

Dimensions — 201CRD-W and 301CRD-W

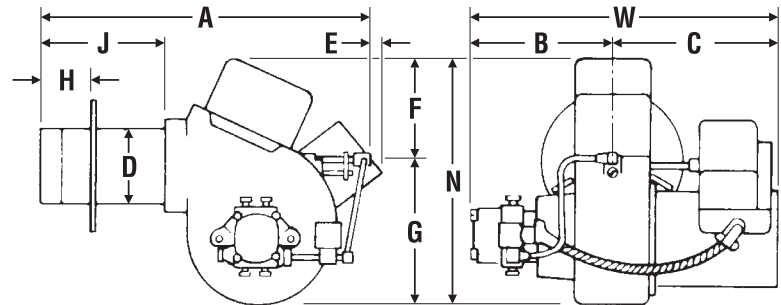

Dimensions — 702CRD-W and 801CRD-W

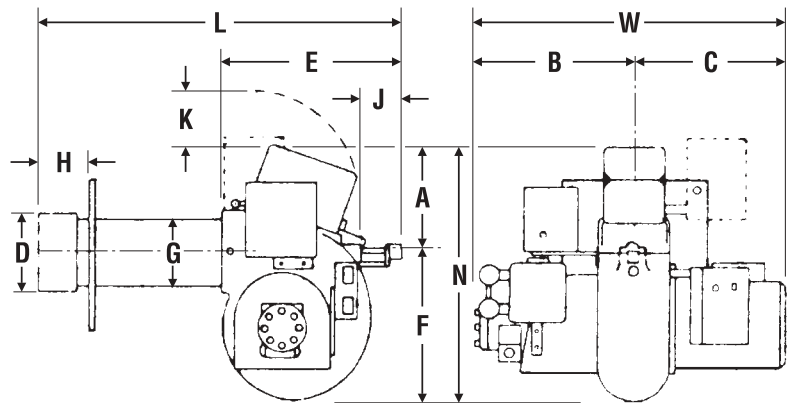

Burner Model Number	Dimensions in inches												
	A	B	C	D	E	F	G	H	J	K	L	N	W
EZ-3HP-W	14.00	-	-	4.00	7.00	4.00	6.75	3.00	7.00	-	-	10.75	12.50
201CRD-W	18.63	7.88	8.38	4.13	1.00	5.50	7.75	3.00	7.00	-	-	13.25	16.25
301CRD-W	17.44	7.88	8.38	4.13	1.00	5.50	7.75	3.00	7.00	-	-	13.25	16.25
702CRD-W	7.50	9.50	10.00	5.88	13.00	9.00	4.13	4.00	3.00	3.00	20.75	16.50	19.50
801CRD-W	8.00	12.00	11.00	5.88	14.50	10.50	5.25	4.00	3.00	3.00	20.50	18.50	23.00



Weil-McLain
 500 Blaine Street
 Michigan City, IN 46360-2388
<http://www.weil-mclain.com>