

# Technical Data Manual

Model Nos. and pricing: see Price List

# VIESSMANN®

For operation with natural gas and liquid propane gas

Floor mounted, gas-fired condensing boiler

Heating input 19 to 199 MBH

5.6 to 58 kW



## VITOCROSSAL 300



*Product may not be exactly as shown*

### Vitocrossal 300 CU3A Series 26 to 57

Floor mounted, gas-fired condensing boiler with modulating MatriX gas burner.  
For room air dependent or independent operation.



## Benefits

Equipped with the industry's first intelligent combustion management system and powerful control technology, the new generation Vitocrossal 300 CU3A gas-fired Floor mounted condensing boiler delivers unparalleled performance, reliability and comfort.

The benefits at a glance:

- Best value in its class with new industry-leading technology and the most standard features.
- Highest Efficiency up to 98% at full modulation and up to 95% A.F.U.E.
- Lasting performance with industry-leading Viessmann made SA240 316 Ti stainless steel Inox-Crossal heat exchanger constructed to CSA B51 and ASME Section IV.
- Low Emission Combustion with Viessmann made stainless steel MatriX burner. Factory calibrated.
- Fast Installation and Reduced Maintenance with Lambda Pro, industry-first intelligent combustion management system: Adjusts automatically to gas type and quality. No fuel conversion kit required.
- Powerful and User-friendly  
Viessmann Vitotronic on-board multi-function outdoor reset boiler and system control for multi-temperature space and DHW heating.
- Expanded Application Range with increased capacity up to 199 MBH (58 kW). Multi-boiler installation up to 1592 MBH (464 kW) with up to 8 boilers.
- Greater Venting Flexibility with increased vent length [up to 198 ft. (60 m)] and multiple venting options.
  - Horizontal or vertical sealed combustion coaxial venting (field supplied).
  - Horizontal, vertical or hybrid sealed combustion double-pipe venting (field supplied).
  - Horizontal or vertical single-wall venting (field supplied).
- Compact, Esthetic Product Design and zero clearance to combustibles.
- Extremely Quiet Operation; quieter than most refrigerators.
- True High-Altitude Operation up to 10,000 ft. (3,000 m) with simple electronic adjustment.
- Efficiency up to 98% through intensive condensation. The flue gas temperature is only approximately 9-27°F (5-15°C) above boiler return temperature.

# Cross-Section

Vitocrossal 300 CU3A 26 to 57

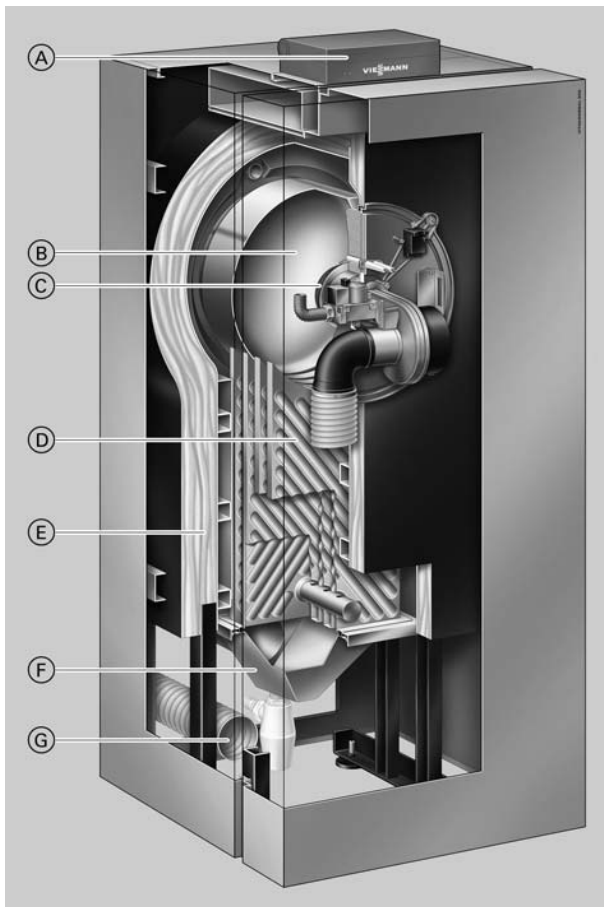

Product may not be exactly as shown

**Legend**

- (A) Digital Vitotronic boiler control unit
- (B) Water-cooled stainless steel combustion chamber
- (C) Modulating MatriX gas burner – for extremely clean combustion
- (D) Stainless steel Inox-Crossal heat exchanger
- (E) Highly effective thermal insulation
- (F) Flue gas collector with condensate drain pipe
- (G) Combustion air intake for direct vent (two-pipe) systems

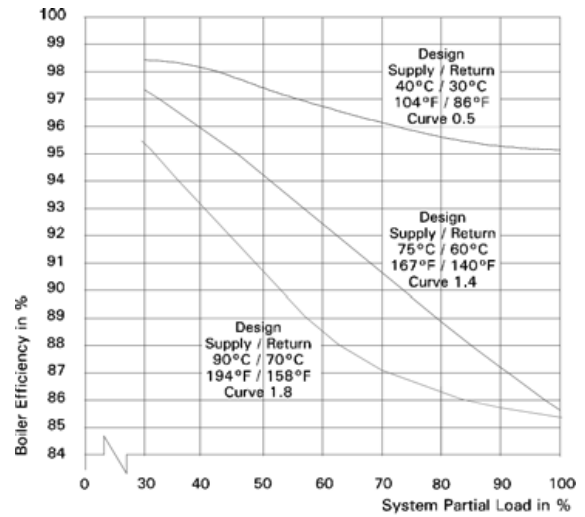

Vitocrossal 300 CU3A boiler efficiency dependent on system heating water return temperatures and load conditions

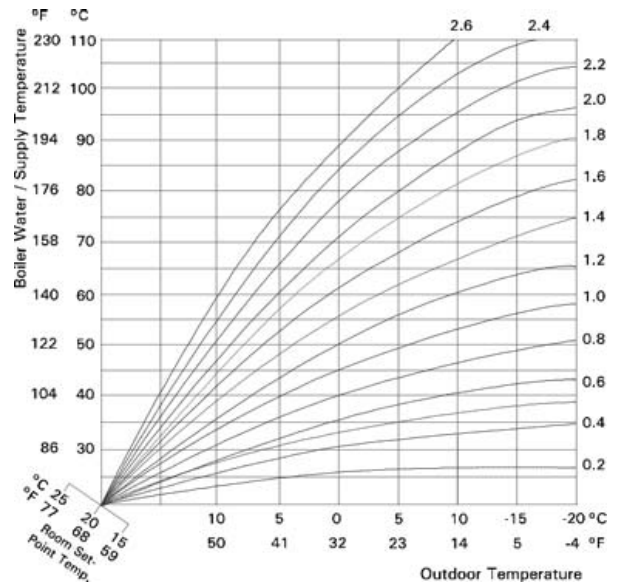

**Technical Data**

Boiler Model No. CU3A		26	35	45	57
<b>Natural Gas / Liquid Propane Gas CSA input</b>	MBH	19-94	25-125	43-160	43-199
	(kW)	(5.6-27.5)	(7.3-36.6)	(12.6-47)	(12.6-58)
<b>CSA output / DOE heating capacity* 1</b>	MBH	17.7-87	23.3-116	40-149	40-185
	(kW)	(5.2-25.5)	(6.8-34)	(11.7-43.7)	(11.7-54.2)
<b>Net AHRI Rating</b>	MBH	76	101	129	161
	(kW)	(22)	(30)	(38)	(47)
<b>Heat exchanger surface area</b>	ft. <sup>2</sup>	16.7	20.7	34.1	34.1
	(m <sup>2</sup> )	(1.5)	(1.9)	(3.2)	(3.2)
<b>Min. gas supply pressure</b>					
Natural gas	"w.c.	4	4	4	4
Liquid propane gas	"w.c.	10	10	10	10
<b>Max. gas supply pressure * 3</b>					
Natural gas	"w.c.	14	14	14	14
Liquid propane gas	"w.c.	14	14	14	14
<b>A.F.U.E.</b>	%	95	95	95	95
<b>Weight</b>	lbs	269	275	352	352
	(kg)	(122)	(125)	(160)	(160)
<b>Boiler water content</b>	USG	13.5	13.0	18.8	18.8
	(L)	(51)	(49)	(71)	(71)
<b>Max. operating pressure at 210°F (99°C)</b>	psig	30	30	30	30
	(bar)	(2)	(2)	(2)	(2)
<b>Boiler water temperature</b>					
- Adjustable high limit (AHL) range space heating (steady state)	°F	68-194	68-194	68-194	68-194
	(°C)	(20-90)	(20-90)	(20-90)	(20-90)
DHW production	°F	194	194	194	194
	(°C)	(90)	(90)	(90)	(90)
- Fixed high limit (FHL)	°F	210	210	210	210
	(°C)	(99)	(99)	(99)	(99)
<b>Boiler connections</b>					
Boiler heating supply and return	NPTM	1 1/4"	1 1/4"	1 1/4"	1 1/4"
Pressure relief valve	NPTF	3/4"	3/4"	3/4"	3/4"
Boiler drain	NPTM	1"	1"	1"	1"
Gas valve connection	NPTF	3/4"	3/4"	3/4"	3/4"

\*1 Output based on 140°F (60°C), 120°F (49°C) system supply/return temperature.

\*2 Net AHRI rating based on piping and pick-up allowance of 1.15.

\*3 If the gas supply pressure exceeds the maximum gas supply pressure value, a separate gas pressure regulator must be installed upstream of the heating system.

**Note:** For high altitude installation at 10,000 ft. the input for model Vitocrossal 300 CU3A will have an altitude de-rating of 18%.

## Technical Data

Boiler Model No. CU3A		26	35	45	57
<b>Dimensions</b>					
Overall depth	inches	27	27	31½	31½
	(mm)	684	684	801	801
Overall width	inches	26	26	26	26
	(mm)	660	660	660	660
Overall height	inches	67	67	67	67
(with control interface open)	(mm)	1707	1707	1707	1707
Overall height	inches	61.5	61.5	61.5	61.5
	(mm)	1562	1562	1562	1562
<b>Flue gas *4</b>					
Temperature (at boiler return temperature of 86°F (30°C))					
- at rated full load	°F (°C)	113 (45)	113 (45)	113 (45)	113 (45)
- at rated partial load	°F (°C)	90 (32)	90 (32)	90 (32)	90 (32)
Temperature (at boiler return temperature of 140°F (60°C))	°F (°C)	167 (75)	167 (75)	167 (75)	167 (75)
<b>Max. condensate flow rate *5</b>					
for NG and LPG					
TS/TR = 104/86°F (40/30°C)	USG/h	0.9	1.2	1.6	2.1
	(L/h)	3.43	4.62	5.95	7.92
<b>Condensate connection</b>					
	hose nozzle				
	Ø in.	¾	¾	¾	¾
<b>Boiler flue gas connection *6</b>					
	Ø in. (mm)	3 (80)	3 (80)	4 (110)	4 (110)
<b>Combustion air supply connection</b>					
	outer Ø in. (mm)	3 (80)	3 (80)	3 (80)	3 (80)
<b>Sound Rating (A scale)</b>					
- at maximum input	dB	48	55	53	58
- at minimum input	dB	32	33	33	33
<b>Standby losses *7</b>					
	BTU/hr	1128	1000	1120	995
	W/hr	330	292	328	291

\*4 Measured flue gas temperature with a combustion air temperature of 68°F (20°C).

\*5 Based on maximum input rate.

\*6 For side wall vent installations (coaxial system):  
Do not exceed max. equivalent length specified in the Installation Instructions of the Vitocrossal 300 CU3A Venting System.  
Do not attempt to common-vent Vitocrossal 300 CU3A with any other appliance.  
Side wall co-axial vent installation must include Viessmann protective screen!  
For details refer to the Installation Instructions for the Vitocrossal 300 CU3A Venting System.

\*7 Standby losses measured from the boiler temperature sensor well based on a boiler water temperature of 158°F (70°C) and a room temperature of 68°F (20°C).

For information regarding other Viessmann System Technology componentry, please reference documentation of respective product.

**Models 300 CU3A 26 to 57**

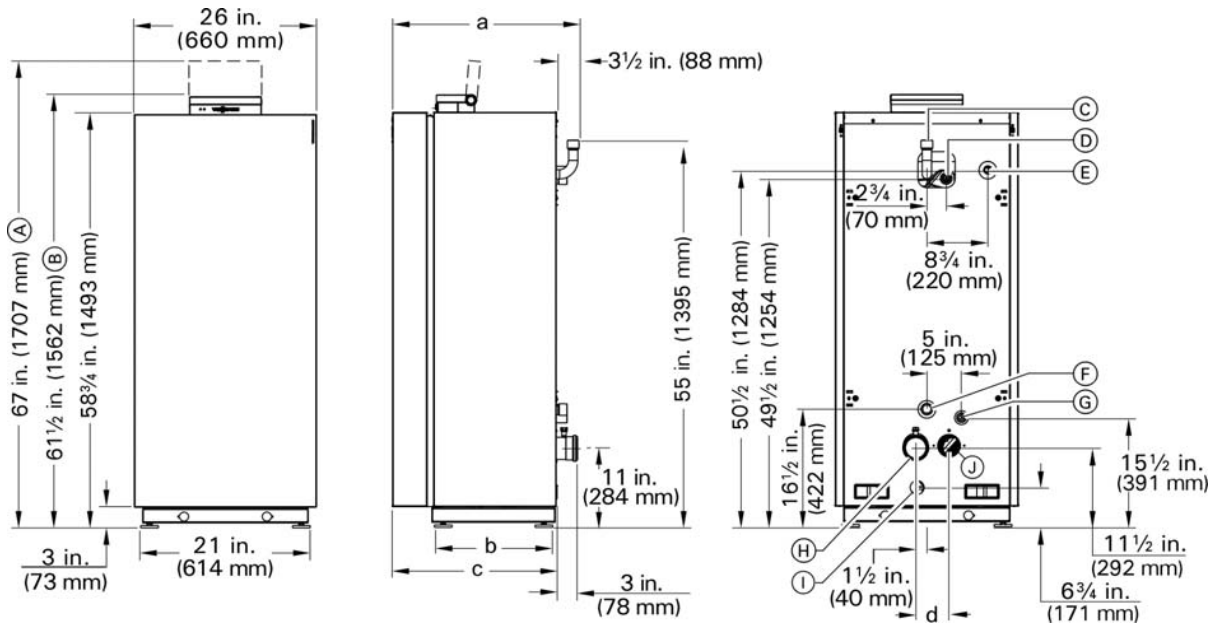

**Legend**

- (A) Overall boiler height (boiler control open)
- (B) Overall boiler height (boiler control closed)
- (C) Safety header connection
- (D) Boiler supply
- (E) Gas connection
- (F) Boiler return
- (G) Boiler drain
- (H) Vent connection
- (I) Condensate drain connection
- (J) Combustion air connection

Model 26 to 35			Model 45 and 57		
a	in. (mm)	27 (684)	a	in. (mm)	31½ (801)
b	in. (mm)	17 (430)	b	in. (mm)	21½ (545)
c	in. (mm)	23½ (595)	c	in. (mm)	28 (712)
d	in. (mm)	4¾ (120)	d	in. (mm)	5½ (140)

**Note:** All height dimensions of the boiler have a tolerance of +.6 in. (+15 mm) due to the factory installed adjustable feet.

**Recommended Minimum Service Clearances**

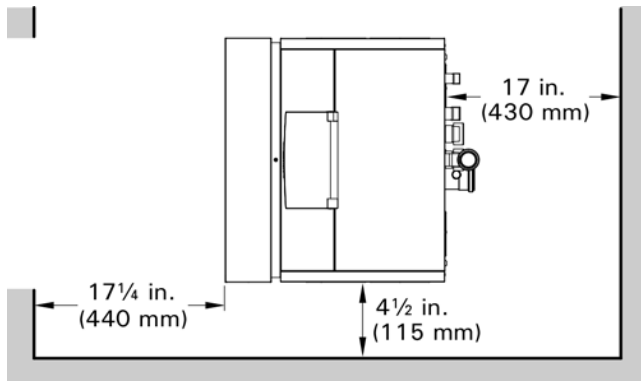

**Note:** The Vitocrossal 300 CU3A series boiler conforms to the zero inches vent clearance to combustibles testing requirements dictated by the boiler Harmonized Standard ANSI Z21.13, CSA/4.9 (latest edition) and therefore is listed for zero clearance to combustibles when vented with a single-wall UL/ULC certified special venting system. The zero inches vent clearance to combustibles for the Vitocrossal 300 CU3A boiler supercedes the clearance to combustibles listing that appears on the special venting system label. The back or side clearance shall be increased if piping installation is required.

**Recommended minimum service clearances**

For typical Vitocrossal CU3A series boiler installations, Viessmann recommends installing the boiler with the service clearances shown in the illustration.



See the Vitocrossal 300 CU3A Venting System Installation Instructions for details.

**Minimum clearances to combustibles**

Boiler model CU3A	26	35	45	57
Top	0	0	0	0
Sides (left and right)	0	0	0	0
Vent pipe	0	0	0	0
Front (alcove or closet)	0	0	0	0
Rear	0	0	0	0
Floor	combustible	combustible	combustible	combustible

The Vitocrossal CU3A series boilers are approved for closet and alcove installation with the clearances to combustibles listed.

**Pressure Drop (heating water side)**

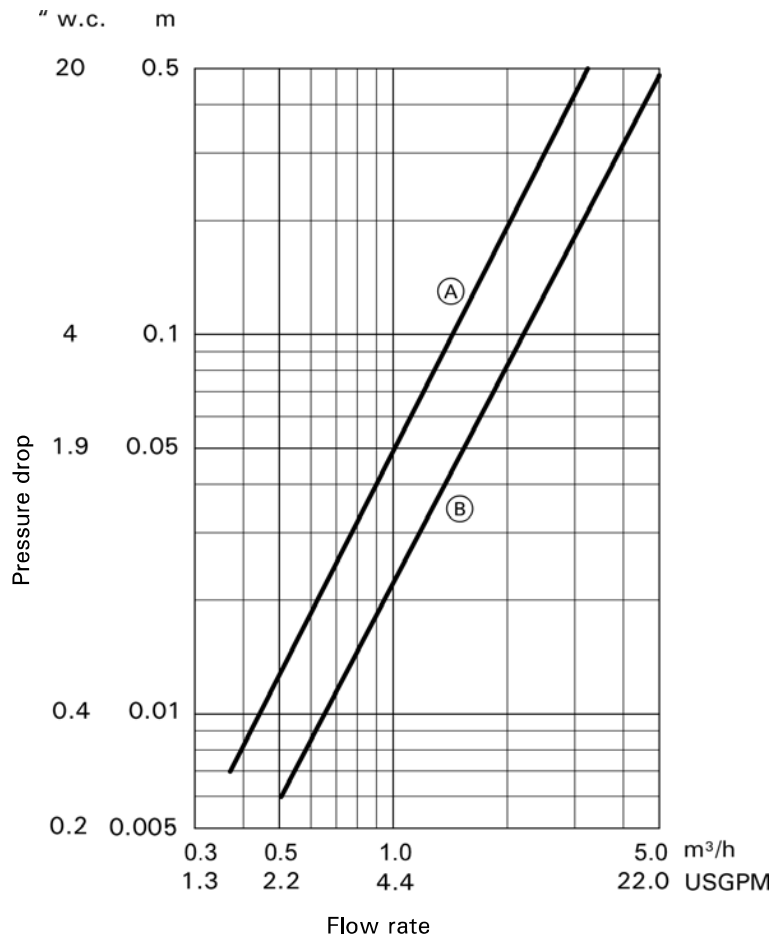

**Legend**

- Ⓐ Boiler models CU3A 26 to 35 kW
- Ⓑ Boiler models CU3A 45 to 57 kW

The Vitocrossal 300 is only suitable for fully pumped hot water heating systems.

Boiler models CU3A	$\Delta T = 20^{\circ}\text{F} (10 \text{ K})$	$\Delta T = 30^{\circ}\text{F} (15 \text{ K})$	$\Delta T = 40^{\circ}\text{F} (20 \text{ K})$
	Flow rate USGPM (m³/h)	Flow rate USGPM (m³/h)	Flow rate USGPM (m³/h)
26	9.9 (2.2)	6.6 (1.5)	4.9 (1.1)
35	13.3 (3.0)	8.9 (2.0)	6.6 (1.5)
45	17.0 (3.9)	11.4 (2.6)	8.5 (2.0)
57	22.7 (5.2)	15.0 (3.4)	11.4 (2.6)

**Note:** This boiler does not require a flow switch.

## On-Board Vitotronic 200, HO1B Control

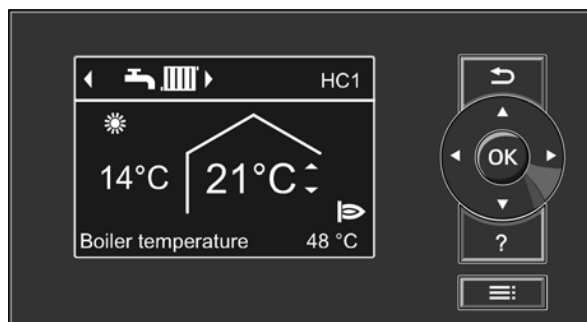

### Modular structure

The control unit is integrated into the boiler. The control unit comprises a standard unit, electronics modules and a programming unit.

Standard unit:

- ON/OFF switch
- Optolink laptop interface
- Operating and fault indicators
- Reset button
- Fuses

### Programming unit:

- Easy operation through:
  - Plain text display with graphic ability
  - Large font and black & white depiction for good contrast
  - Context-sensitive help text
  - Removable programming unit; can be mounted on the wall with separate accessory
- With digital time switch
- Control keys for:
  - Navigation
  - Confirmation
  - Help and additional information
  - Menu
- Setting the:
  - Room temperature
  - Reduced room temperature
  - DHW temperature
  - Heating program
  - Time programs for central heating, DHW heating and DHW recirculation
  - Economy mode
  - Party mode
  - Holiday program
  - Heating curves
  - Codes
  - Actuator tests
  - Test mode
- Displaying the:
  - Boiler water temperature
  - DHW temperature
  - Operating details
  - Diagnostic details
  - Fault messages

## Design and Function

### Functions

- Weather-compensated control of the boiler water and/or supply temperature
- Control of one heating circuit without mixer and two heating circuits with mixer (with accessory mixing valve extension modules)
- Demand-dependent heating circuit pump and burner off control
- Adjustment of a variable heating limit
- Anti-seizing pump protection
- Integral diagnostic system
- Maintenance display
- DHW temperature control with priority
- Auxiliary function for DHW heating (short-term heating to a higher temperature)
- 0-10V External signal input
- 0-10V Pump speed control output signal

### Control Characteristics

PI characteristics with modulating output.

### Time Switch

Digital time switch.

- Individual and 7-day program
- Automatic daylight savings time changeover
- Automatic function for DHW heating and DHW recirculation pump
- Time, day and standard switching times for space heating, DHW heating and the DHW recirculation pump are factory-set
- Switching times are individually programmable, i.e. up to four switching periods per day  
Shortest switching interval: 10 minutes  
Power backup: 14 days.

### Setting the Operating Programs

The heating system frost protection (see frost protection function) applies to all heating programs. You can select the following heating programs with the program keys:

- Heating and DHW
- DHW only
- Standby mode

External heating program changeover.

### Frost protection

- The frost protection function will be started when the outside temperature drops below approx. 34°F (1°C). With the frost protection function, the heating circuit pump will be switched ON and the boiler water is maintained at a lower temperature of approx. 68°F (20°C). The DHW tank will be heated to approx. 68°F (20°C).
- The frost protection function will be stopped when the outside temperature rises above approx. 37°F (3°C) (default settings).

### Summer Operation

Heating program “”

The burner is only activated upon a call for domestic hot water from the DHW storage tank (controlled by DHW tank temperature sensor).

**Design and Functions** *(continued)*

**Technical Data**

Rated supply voltage:	120VAC
Rated frequency:	60 Hz
Rated current:	Less than 12 A
Max. ambient temp.	
- at operation:	32 to 104°F (0 to 40°C) Installation in living spaces or boiler rooms (standard ambient conditions)
- when storing or transporting:	-4 to +158°F (-20 to +70°C)
Max. operating temp. setting (space heating):	194°F (90°C)
DHW production:	194°F (90°C)
Setting fixed high limit (not adjustable)	210°F (99°C)
Adjustment range of DHW tank set-point temperature:	50 to 149°F (10 to 65°C)
Heating curve settings	
- Heating curve slope:	0.2 to 3.5
- Heating curve shift:	-12 to +33°C -13 to 40 K

**Heating Curve Adjustment (slope and shift)**

The control unit regulates the boiler water temperature (= supply temperature of heating circuit without mixing valve) and the supply temperature of the heating circuit with mixing valve (in conjunction with the accessory kit for a heating circuit with mixing valve) according to the outdoor temperature. The boiler water temperature is automatically raised by 0 to 72 F / 0 to 40 K higher than the currently required set supply temperature (in the factory default setting the differential temperature is 14.4 F / 8 K). See Service Instructions for coding address "9F" in coding level 2.

The supply temperature that is required to achieve a given room temperature depends on the heating system and the thermal insulation of the building that is being heated.

The adjustment of the two heating curves is used to match the boiler water temperature and the supply temperature to these conditions. The boiler water temperature is limited upwards by the fixed high limit and the temperature set for the electronic high limit. The supply temperature cannot rise above the boiler water temperature.

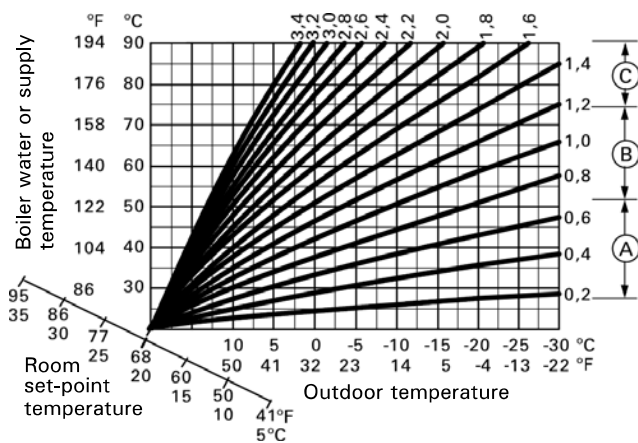

**Legend**

- (A) Low temperature heating system, e.g. radiant floor heating
- (B) Medium temperature heating system, e.g. cast iron radiation, staple-up radiant floor heating
- (C) High temperature heating system, e.g. fintube radiation, fan coils

**Sensors**

**Boiler Temperature Sensor (supplied)**

The boiler temperature sensor is connected at the control unit for weather-responsive operation and is built into the boiler.

Specification sensor type: Viessmann NTC 10K ohms at 77°F (25°C)

Max. ambient temp.

- at operation: 32 to 266°F (0 to 130°C)
- when storing or transporting: - 4 to + 158°F (-20 to + 70°C)

**DHW Tank Temperature Sensor (supplied)**

- integrated DHW temperature sensor

**Immersion Temperature Sensor (accessory)**

To capture the low loss temperature (if the LLH is used)

Specification

Lead length fully wired: 12 ft. (3.75 m),

Permissible ambient temp.

- during operation: 32 to 194°F (0 to 90°C)
- when storing or transporting: - 4 to + 158°F (-20 to + 70°C)

**Outdoor Temperature Sensor (supplied)**

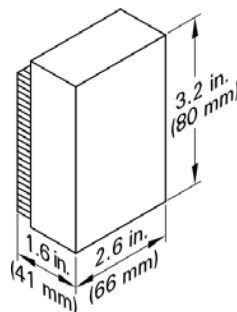

Sensor location:

- North or northwest wall of building
- 6.6 to 8.2 ft. (2 to 2.5 m) above ground or in case of a multi-storey building approximately halfway up the second floor

Electrical connection:

- 2-wire cable, max. cable length 115 ft. (35 m) with a wire size of min. AWG 16 copper
- Cable to the outdoor sensor must not be laid near line voltage wiring (120/240V)

Max. ambient temperature during transport, storage and operation:

-40 to 194°F (-40 to 90°C)

**Optional Accessories**

**Supply Temperature Sensor**

(strap-on sensor, included with mixing valve actuator accessory kit),

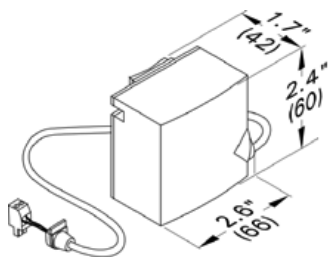

- when storing or transporting: -4 to + 158°F (-20 to + 70°C)

Installed with a strapping band.

Cable length 19.7 ft. (6 m), ready to plug in.

Max. ambient temp.

- at operation: 32 to 212°F (0 to 100°C)
- when storing or transporting: -4 to + 149°F (-20 to + 70°C)

**KM BUS Expansion Module**

To connect 2 to 9 devices (mixing valve actuator, Vitotrol, input module, etc.) to the single KM BUS connection of the boiler.

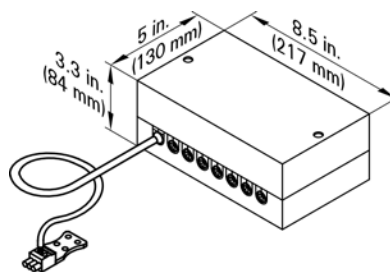

Specification

Lead length 10 ft. (3.0 m), fully wired

Permissible ambient temp.

- during operation: 32 to 104°F (0 to 40°C)

- during storage and transport:

- 4 to + 149°F (-20 to + 65°C)

**Optional Accessories** *(continued)*

**Room Temperature Sensor,**

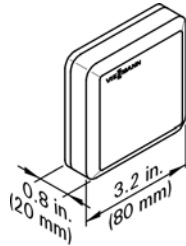

Separate room temperature sensor as supplement to the Vitotrol 200A and 300A; to be used if the Vitotrol 200A or 300A cannot be installed inside the main living room or in a suitable position where the unit can capture and adjust the temperature.

Installation in the main living room on an internal wall opposite radiators. Never install inside shelf units, recesses, immediately by a door or heat source (e.g. direct sunlight, fireplace, TV set, etc.).

Connect the room temperature sensor to the Vitotrol 200A or 300A.

Electrical connection:

- 2-wire cable with a wire size of min. AWG 18 copper
- The cable length between the control unit, remote control unit and room temperature sensor must not exceed 98 ft. (30 m)

Max. ambient temp.

- at operation: 32 to 104°F (0 to 40°C)
- when storing or transporting: -4 to + 149°F (-20 to + 65°C)

**Mixing Valve Extension Module**

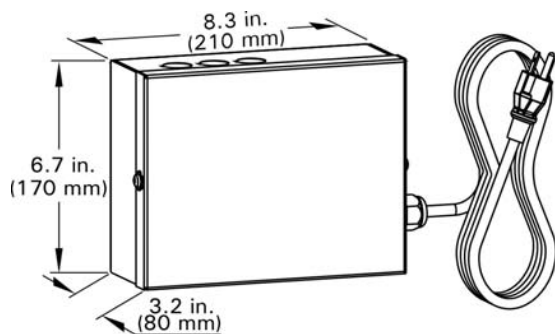

- Rated voltage: 120VAC
- Rated frequency: 60 Hz
- Rated current: 2 A
- Power consumption: 4 W
- Max. ambient temp.
- at operation: 32 to 104°F (0 to 40°C)
- when storing or transporting: -4 to + 149°F (-20 to + 65°C)
- Relay output for heating circuit pump: 2 A, 120VAC
- Actuator torque: 3 Nm
- Time of 90°: 120 seconds

**Mixing Valve Actuator Kit**

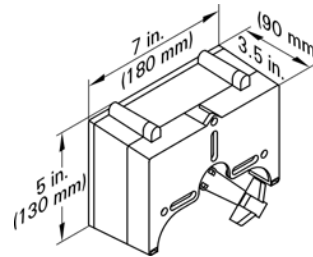

The mixing valve actuator is mounted directly on the Viessmann 3/4 to 2 1/2" mixing valve. The mixing valve actuator is a motor-driven control unit. The rotational direction is reversible.

- Rated voltage: 120VAC
- Rated frequency: 60 Hz
- Power consumption: 4W max. ambient temperature
- at operation: 32° F to 104°F (0° C to 40°C)

application in living areas and installation sites (normal ambient conditions)

- storage & shipping: -4°F to 149°F (-20°C to 65°C)

**LON Communication Module**

Electronic PCB for data exchange with the Vitotronic 200-H, Vitocom 200 and for connecting to a higher level building management system.

**LON Connecting Cable**

(for data exchange between control units)  
Cable length 23 ft. (7 m), fully wired

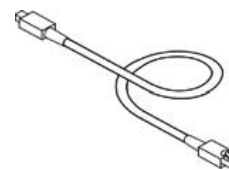

**LON Terminal End Resistor**

To terminate the LON BUS at the first and the last control unit.

## Optional Accessories *(continued)*

### Vitotrol 200A

One Vitotrol 200A can be used for every heating circuit in a heating system. The Vitotrol 200A can regulate one heating circuit and up to two remote controls may be connected to the control unit.

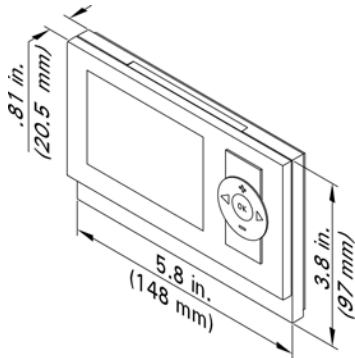

#### KM BUS Participant

The Vitotrol 200A remote control regulates the required set room temperature in standard mode, from any room in the house.

- Party and economy mode can be enabled via keys
- Only for heating circuit with mixing valve
- Fitted room temperature sensor for room temperature hook-up

#### WS function:

Installation anywhere in the building.

#### RS function:

**Note:** Never activate the RS function for underfloor heating circuits (inertia). In heating systems with a heating circuit without mixing valve and heating circuits with mixing valve, the RS function must only affect the heating circuit with mixing valve.

#### Room temperature hook-up:

Installation in the main living room on an internal wall opposite radiators. Never install inside shelf units, recesses, immediately by a door or heat source (e.g. direct sunlight, fireplace, TV set, etc.).

The integral room temperature sensor captures the actual room temperature and effects any necessary corrections of the supply temperature as well as a rapid heat-up at the start of the heating operation (if appropriately programmed).

#### Connection:

- 2-core lead 18 AWG, length max. 164 ft. (50 m) (even if connecting several remote control units)
- Never route this lead immediately next to 120/208/460 V cables
- LV plug as standard delivery must be installed in the main living room (lead room).

#### Specification:

Power supply via KM BUS

Power consumption: 0.2 W

Max. ambient temp.

- at operation: 32 to 104°F (0 to 40°C)

- when storing

or transporting: -4 to +149°F (-20 to +65°C)

Set room temp. range 37 to 99°F (3 to 37°C)

The set room temperature for reduced mode is adjusted at the control unit.

## Optional Accessories *(continued)*

### Vitotrol 300A

One Vitotrol 300A can be used for every heating circuit in a heating system. The Vitotrol 300A can regulate up to three heating circuits. Up to two remote controls may be connected to the control unit.

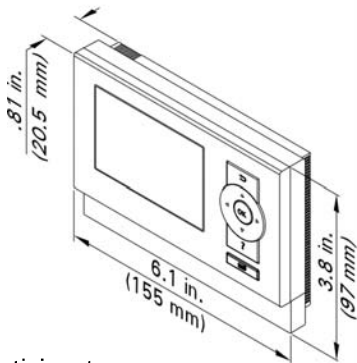

#### KM BUS Participant

The Vitotrol 300A remote control regulates the required set room temperature for one heating circuit in standard and reduced mode, the heating program and the switching times for central heating, DHW heating and the DHW recirculation pump.

#### Displaying:

- Room temperature
- Outside temperature
- Heating program
- Operating condition
- Solar yield as graphic display

#### Settings:

- Set room temperatures for standard mode (day temperature) and reduced mode (night temperature) via the standard display
- Heating program, switching times for heating circuits, DHW heating and DHW recirculation pump plus further settings via plain text menu on the display
- Party and economy mode can be enabled via the menu
- Only for heating circuit with mixer:  
Fitted room temperature sensor for room temperature hook-up

**Note:** For room temperature hook-up, the Vitotrol 300A must be installed in the main living room (lead room).

#### RS function:

Installation in the main living room on an internal wall opposite radiators. Never install inside shelving units, in recesses, or immediately by a door or heat source (e.g. direct sunlight, fireplace, TV set, etc.). The fitted room temperature sensor captures the actual room temperature and effects any necessary correction of the flow temperature.

#### WS function:

Installation anywhere in the building.

#### Connection:

- 2-core lead 18 AWG, length max. 164 ft. (50 m) (even if connecting several remote control units)
- Never route this lead immediately next to 120/208/460V cables
- LV plug as standard delivery must be installed in the main living room (lead room).

#### Specification:

Power supply via KM BUS

Power consumption: 0.2 W

Max. ambient temp.

- at operation: 32 to 104°F (0 to 40°C)
- when storing or transporting: -4 to + 149°F (-20 to + 65°C)

Set room temp. range 37 to 99°F (3 to 37°C)

The set room temperature for reduced mode is adjusted at the control unit.

## Accessories for Vitocrossal 300 CU3A

### Fuel Conversion Label Kit (NG > LPG)

(included in boiler technical literature set)

The Vitocrossal 300 CU3A boiler comes factory set for operation with natural gas. All Vitocrossal 300 CU3A models can be field converted to operate with liquid propane gas (as well as back to natural gas as required). The kit includes instructions and labels for field conversion.

### Low-Loss Header

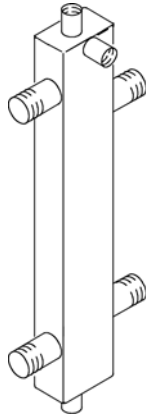

When used in conjunction with the Vitocrossal 300 CU3A boiler, the low-loss header acts as hydraulic break, decoupling boiler and system circuits from each other.

Viessmann recommends the use of a low-loss header in cases where the system head and flow rates are unknown.

The temperature sensor connection [TS] typically located at the top of the low-loss header ensures low return temperatures to the Vitocrossal 300 CU3A boiler at all times, increasing operational efficiency.

### IMPORTANT

**Use only a Viessmann temperature sensor (accessory).  
Do not use any other manufacturer's temperature sensor.**

In addition, the low-loss header helps eliminate air and debris [D] from the heating system. See illustrations for design and principle of operation.

### Low-loss header design (Typical)

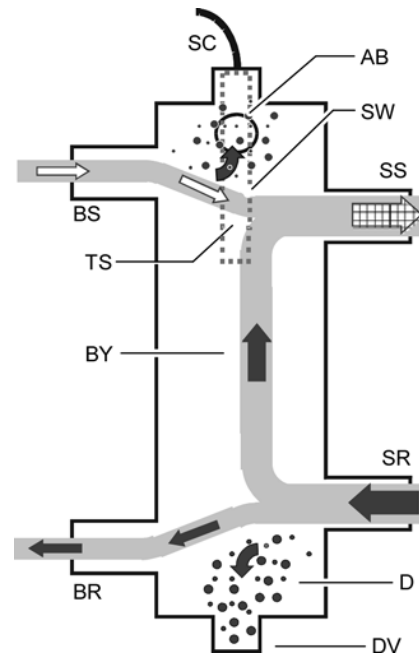

### Legend

AB	Air Bleed
BR	Boiler Return
BS	Boiler Supply
BY	Bypass (with laminar flow)
D	Debris and/or air
DV	Drain Valve
SC	Sensor Cable
SR	System Return
SS	System Supply
TS	Viessmann Temperature Sensor
SW	Sensor Well

# Accessories for Vitocrossal 300 CU3A

## Low-Loss Header (continued)

### Principle of Operation

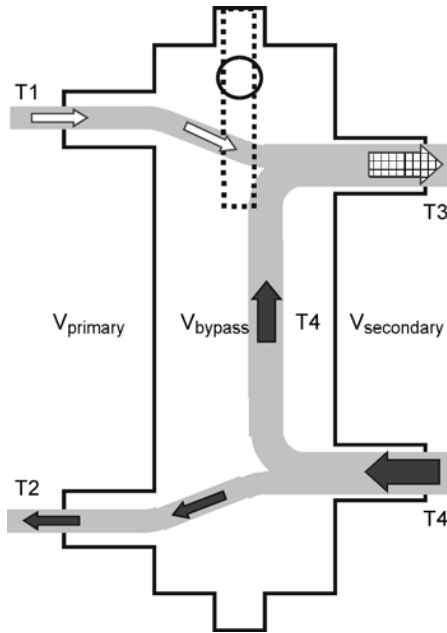

### Legend

- T1 Boiler supply temperature
- T2 Boiler return temperature
- T3 System supply temperature
- T4 System return temperature
- Vprimary Boiler circuit flow rate
- Vsecondary Heating circuit flow rate
- Vbypass Bypass flow rate
- Qprimary Heat supplied by boiler
- Qsecondary Heat consumed by system

## IMPORTANT

When installing a low-loss header, the system mixed supply temperature (T3) must be calculated as follows:

$$T3 = \frac{T1 \times V_{primary} + T4 \times V_{bypass}}{V_{secondary}}$$

$$V_{primary} < V_{secondary}$$

$$T1 > T3$$

$$T2 = T4$$

$$Q_{primary} = Q_{secondary}$$

$$T1 \ 167^{\circ} \text{ F } (75^{\circ} \text{ C})$$

$$V_{secondary} = V_{primary} + V_{bypass}$$

Model No.	Max. system flow rate
Type 80/60	17.6 USGPM (4 m <sup>3</sup> /h)
Type 120/80	35.2 USGPM (8 m <sup>3</sup> /h)
Type 160/80 *1	44 USGPM (10 m <sup>3</sup> /h)
Type 200/120 *1	80 USGPM (18 m <sup>3</sup> /h)

\*1 Floor-mounted version (typically used for multiple-boiler installations).

## Standard Equipment

The Vitocrossal 300 CU3A gas-fired condensing combi-boiler with Inox-Crossal heat exchanger, modulating MatriX burner for liquid propane gas and natural gas (available on all models), comes standard with:

- boiler control unit with outdoor temperature sensor, power/pump module:
  - installation fittings with 30 psig pressure relief valve
  - Temperature and pressure gauge field installation on supply pipe.
  - The boiler comes prewired and fully piped internally for field connections.
  - Side wall vent installations must include Viessmann protective screen!
  - Enclosure finish: black steel, powder-coated Viessmann silver
  - The Vitocrossal 300 CU3A comes ready for use with natural gas and can be fuel converted to liquid propane gas in the field.

## Combustion Management System

The combustion management system utilizes the physical correlation between the level of the ionization current and the air factor  $\lambda$ . For all gas qualities, the maximum ionization current results with air factor  $\lambda$ .

The ionization signal is evaluated by the combustion management system, and the air factor is adjusted to between  $\lambda = 1.24$  and  $1.44$ . This range provides for an optimum combustion quality. Thereafter, the electronic gas valve regulates the required gas volume based on the prevailing gas quality.

To check the combustion quality, the CO<sub>2</sub> content or the O<sub>2</sub> content of the flue gas is measured. The actual values enable the prevailing air factor to be determined. The relationship between the CO<sub>2</sub> or O<sub>2</sub> content and air factor  $\lambda$  is illustrated in the table below.

To achieve an optimum combustion control, the system regularly performs an automatic self-calibration; also after a power failure (shutdown). For this, the combustion is briefly regulated to max. ionization current (equals air factor  $\lambda = 1$ ). The automatic calibration is performed shortly after the burner starts and lasts approximately 5 seconds. During the calibration, higher than normal CO<sub>2</sub> emissions may occur briefly.

Air factor  $\lambda$  - CO<sub>2</sub>/O<sub>2</sub> content

Air factor $\lambda$	O <sub>2</sub> content (%)	CO <sub>2</sub> content (%) for natural gas	CO <sub>2</sub> content (%) for liquid propane gas
1.20	3.8	9.6	11.3
1.24	4.4	9.2	10.9
1.27	4.9	9.0	10.6
1.30	5.3	8.7	10.3
<b>1.34</b>	<b>5.7</b>	<b>8.5</b>	<b>10.0</b>
1.37	6.1	8.3	9.8
1.40	6.5	8.1	9.6
1.44	6.9	7.8	9.3
1.48	7.3	7.6	9.0

The Vitocrossal 300 CU3A boilers come equipped with Lambda Pro, the industry's first intelligent combustion management system. The boiler adjusts automatically to any gas type and quality without the need for a fuel conversion kit.

## Hydraulic Connection

### System design

Viessmann condensing boilers can generally be installed in any pumped hot water heating system (closed system). Minimum system pressure 14 psi.

The boiler water temperature is limited to 194°F (90°C). To minimize distribution losses and for increased efficiency we recommend that you size the heat distribution system to a max. supply temperature of 158°F (70°C). This can be achieved through the use of a low temperature heating system (such as a radiant floor).

For apartments with less than 860 ft<sup>2</sup> (80 m<sup>2</sup>) living space or for low energy houses with low heat demand we recommend, due to the immediate capturing of the room-influencing factors, the utilization of the Vitocrossal 300 CU3A in conjunction with the Vitotrol 200A / 300A and room dependant control.

The use of a low loss header is not necessarily required for single boiler CU3A installations. Use of a low loss header when used with the CU3A offers additional benefits as they can be an effective method of air separation, debris removal, temperature sensing and in installations where the flow rates are unknown.

## Installation Examples

Please note that in the following piping layout examples all pumps external to the boiler are field supplied.

### IMPORTANT

The examples on the following pages depict possible piping layouts of the Vitocrossal 300 CU3A boiler equipped with Viessmann System Technology.

Please note that the following examples are simplified conceptual drawings only!

Piping and necessary componentry must be field verified. A low water cut-off (LWCO) must be installed where required by local codes.

Proper installation and functionality in the field is the responsibility of the heating contractor.

# System Layout 1

Vitocrossal 300 CU3A with a direct-connected heating circuit

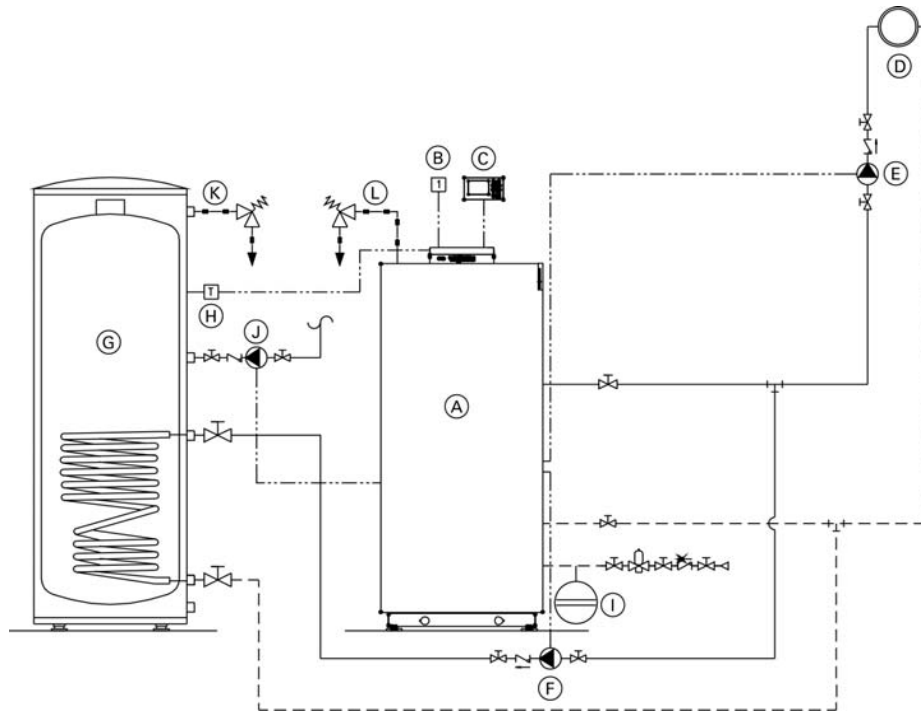

**Legend**

- Ⓐ Vitocrossal 300 CU3A boiler with Vitotronic 200, KW6B outdoor reset control
- Ⓑ Outdoor temperature sensor [1]
- Ⓒ Vitotrol remote (optional)
- Ⓓ Heating circuit
- Ⓔ Heating circuit pump [20]
- Ⓕ DHW pump [21]
- Ⓖ DHW storage tank
- Ⓗ DHW tank temperature sensor [5]
- Ⓘ Expansion tank
- Ⓝ DHW recirculation pump [28/20] \*
- Ⓚ Temperature and pressure relief valve
- Ⓛ Pressure relief valve

**Installation of ...**

- radiator heating circuit (high-temp. circuit)
- DHW production

\* Function based on coding of address 33

## System Layout 2

Vitocrossal 300 CU3A with...

- DHW storage tank
- one heating circuit with mixing valve and system separation

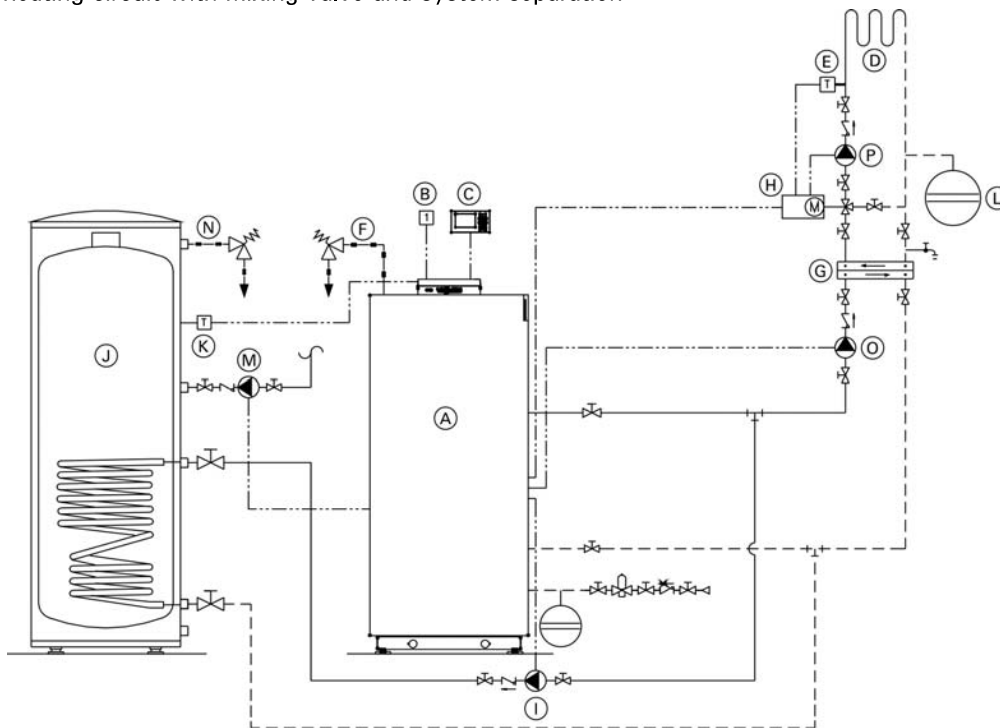

### Legend

- (A) Vitocrossal 300 CU3A boiler with Vitotronic 200, KW6B outdoor reset control
- (B) Outdoor temperature [1]
- (C) Vitotrol remote (optional)
- (D) Underfloor heating circuit
- (E) Mixing valve temperature sensor [2]
- (F) Pressure relief valve
- (G) Plate heat exchanger for system separation
- (H) Accessory kit for heating circuit with mixing valve
- (I) DHW circulating pump [21]
- (J) DHW storage tank
- (K) DHW tank temperature sensor [5]
- (L) Expansion tank
- (M) DHW recirculation pump [28/20] \*
- (N) Temperature and pressure relief valve
- (O) Heating circuit pump [20]
- (P) Heating circuit pump

\* Function based on coding of address 33

### Installation of ...

- underfloor heating circuit with 3-way mixing valve and system separation (low-temp. circuit)
- DHW production

### IMPORTANT

System separation is required of underfloor heating systems employing non-oxygen diffusion barrier tubing. All components on the secondary side of the heat exchanger must be made of corrosion-resistant materials.

### IMPORTANT

Sizing of field-supplied pump (P) is critical for proper boiler operation in this system layout. See page 8 for the supply head pressure drop of the boiler. An undersized pump may cause short-cycling and/or improper operation of the boiler.

Vitocrossal 300 CU3A with...

- DHW storage tank
- one direct-connected heating circuit
- two heating circuit with a mixing valve

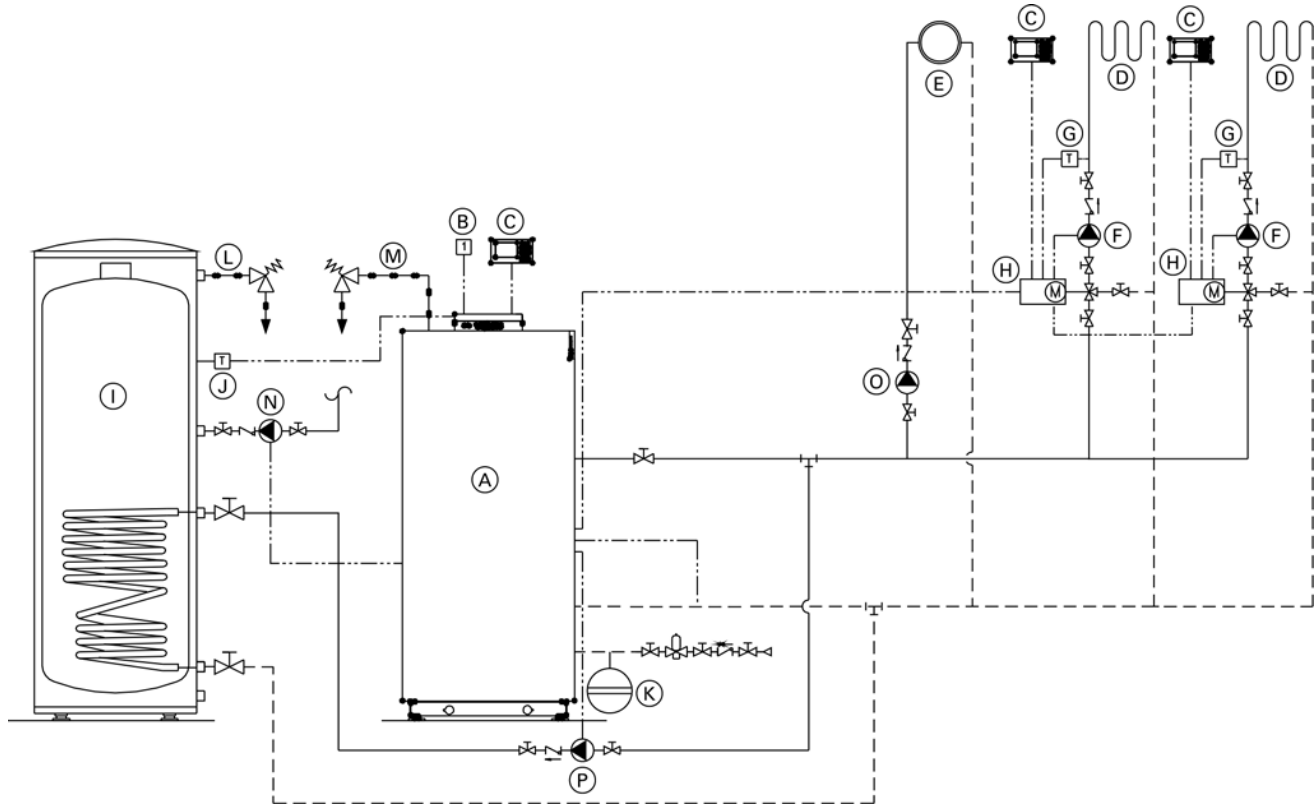

**Legend**

- (A) Vitocrossal 300 CU3A boiler with Vitotronic 200, KW6B outdoor reset control
- (B) Outdoor temperature sensor [1]
- (C) Vitotrol remote (optional)
- (D) Under floor heating circuit
- (E) Radiator heating circuit
- (F) Heating circuit pump
- (G) Mixing valve temperature sensor [2]
- (H) Accessory kit for heating circuit with mixing valve
- (I) Domestic hot water storage tank
- (J) DHW tank temperature sensor [5]
- (K) Expansion tank
- (L) Temperature and pressure relief valve
- (M) Pressure relief valve
- (N) DHW recirculation pump [28/20] \*
- (O) Boiler pump [20]
- (P) DHW circulating pump [21]

\* Function based on coding of address 33

Installation of different heating circuits...

- radiator heating circuit (high-temp. circuit)
- under floor heating circuit with 3-way mixing valve (low-temp. circuit)
- DHW production

The 3-way mixing valve, built-in to achieve the low-temperature level of the under floor heating circuit, is controlled by an accessory kit for a heating circuit with mixing valve.

**IMPORTANT**

System separation is required of underfloor heating systems employing non-oxygen diffusion barrier tubing. All components on the secondary side of the heat exchanger must be made of corrosion-resistant materials.

**IMPORTANT**

Sizing of field-supplied pump (P) is critical for proper boiler operation in this system layout. See page 8 for the supply head pressure drop of the boiler. An undersized pump may cause short-cycling and/or improper operation of the boiler.

## System Layout 4

Vitocrossal 300 CU3A with...

- direct-connected heating circuit
- one heating circuit with system separation

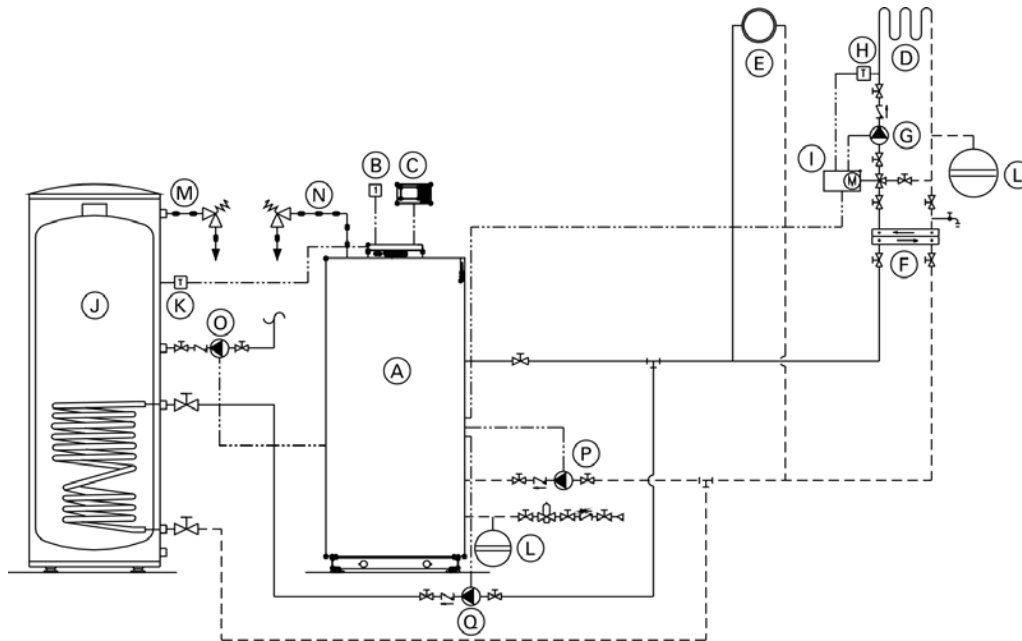

### Legend

- (A) Vitocrossal 300 CU3A boiler with Vitotronic 200, KW6B outdoor reset control
- (B) Outdoor temperature sensor [1]
- (C) Vitotrol remote (optional)
- (D) Under floor heating circuit
- (E) Radiator heating circuit
- (F) Plate heat exchanger for system separation
- (G) Heating circuit pump
- (H) Mixing valve temperature sensor [2]
- (I) Accessory kit for heating circuit with mixing valve
- (J) DHW storage tank
- (K) DHW tank temperature sensor [5]
- (L) Expansion tanks
- (M) Temperature and pressure relief valve
- (N) Pressure relief valve
- (O) DHW recirculation pump [28/20] \*
- (P) Boiler pump [20]
- (Q) DHW circulating pump [21]

\* Function based on coding of address 33

### Installation of different heating circuits...

- radiator heating circuit (high-temp. circuit)
- under floor heating circuit with 3-way mixing valve (low-temp. circuit)
- DHW production

The 3-way mixing valve, built-in to achieve the low-temperature level of the under floor heating circuit, is controlled by an accessory kit for a heating circuit with mixing valve (I). The boiler pump [20] supplies the radiator heating circuit and the plate heat exchanger for system separation.

### IMPORTANT

The pressure drop (secondary circuit) of the plate heat exchanger (F) must be less/equal to the pressure drop of the 3-way mixing valve. This must be taken into account when sizing the plate heat exchanger.

## System Layout 5

Vitocrossal 300 CU3A with...

- DHW storage tank
- low-loss header
- multiple heating circuits with mixing valves
- one heating circuit without mixing valve

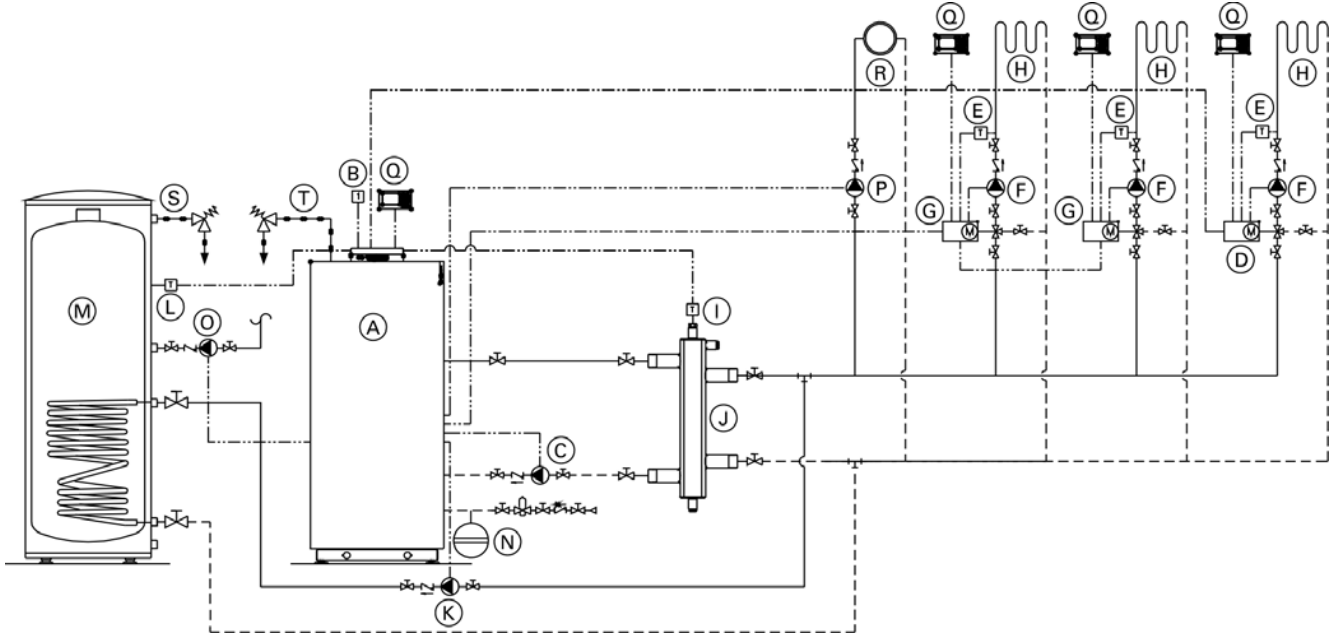

When designing a system as illustrated above, please contact your local Viessmann Sales Representative for assistance.

### Legend

- (A) Vitocrossal 300 CU3A boiler with Vitotronic 200, KW6B outdoor reset control
- (B) Outdoor temperature [1]
- (C) Boiler pump [20]
- (D) Vitotronic 200-H, HK1B \*1
- (E) Mixing valve temperature sensor [2]
- (F) Heating circuit pumps
- (G) Accessory kit for heating circuit with mixing valve
- (H) Heating circuits with mixing valves
- (I) Viessmann temperature sensor for low-loss header [2]
- (J) Low-loss header (if required)
- (K) DHW circulating pump [21]
- (L) DHW tank temperature sensor [5]
- (M) DHW storage tank
- (N) Expansion tank
- (O) DHW recirculation pump [28]
- (P) Heating circuit pump [28/20]\*
- (Q) Vitotrol remote (optional)
- (R) Radiator heating circuit
- (S) Temperature and pressure relief valve
- (T) Pressure relief valve

\* Function based on coding of address 33

\*1 Contact your local Sales Representative for details.

Vitotronic 200-H, HK1B mixing valve control with LON communication module can be used instead of the accessory kit and Vitocontrol.

### IMPORTANT

Please note location of expansion tank (N).

### IMPORTANT

**System separation is required of underfloor heating systems employing non-oxygen diffusion barrier tubing. All components on the secondary side of the heat exchanger must be made of corrosion-resistant materials.**

## System Layout 6

Multiple (up to eight) Vitocrossal 300 CU3A with...

- multiple heating circuits with mixing valves
- low-loss header

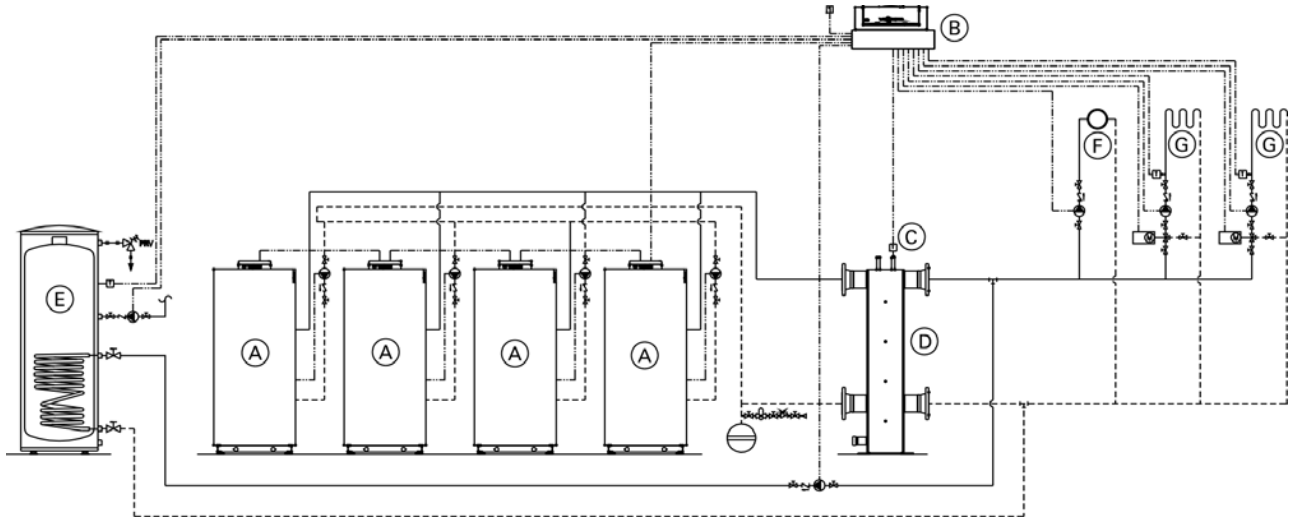

### Legend

- (A) Vitocrossal 300 CU3A boiler
- (B) Vitotronic 300K, MW2C
- (C) Low-loss header/common supply temperature sensor
- (D) Low-loss header
- (E) DHW storage tank
- (F) High temperature heating circuit
- (G) Low temperature heating circuit

When designing a multiple Vitocrossal 300 CU3A system as shown above, please reference applicable multiple Vitocrossal 300 CU3A technical documentation, and contact your local Viessmann Sales Representative for further assistance.

This installation example depicts a possible piping layout for multiple Vitocrossal 300 CU3A boilers equipped with Viessmann System Technology. Please note that this example is based on a simplified conceptual drawing only! Piping and necessary componentry must be field verified. A low water cut-off (LWCO) must be installed where required by local codes.

Proper installation and functionality in the field is the responsibility of the heating contractor.

### WARNING

If a DHW storage tank other than a Viessmann Vitocell 100 or 300 tank is used, the installer must verify proper operation of the Viessmann DHW tank temperature sensor with the original manufacturer of the tank. Viessmann strongly recommends the installation of a temperature tempering valve in the DHW supply line.

## System Layout 7

Multiple (up to eight) Vitocrossal 300 CU3A with...

- system pump
- boiler isolation valves

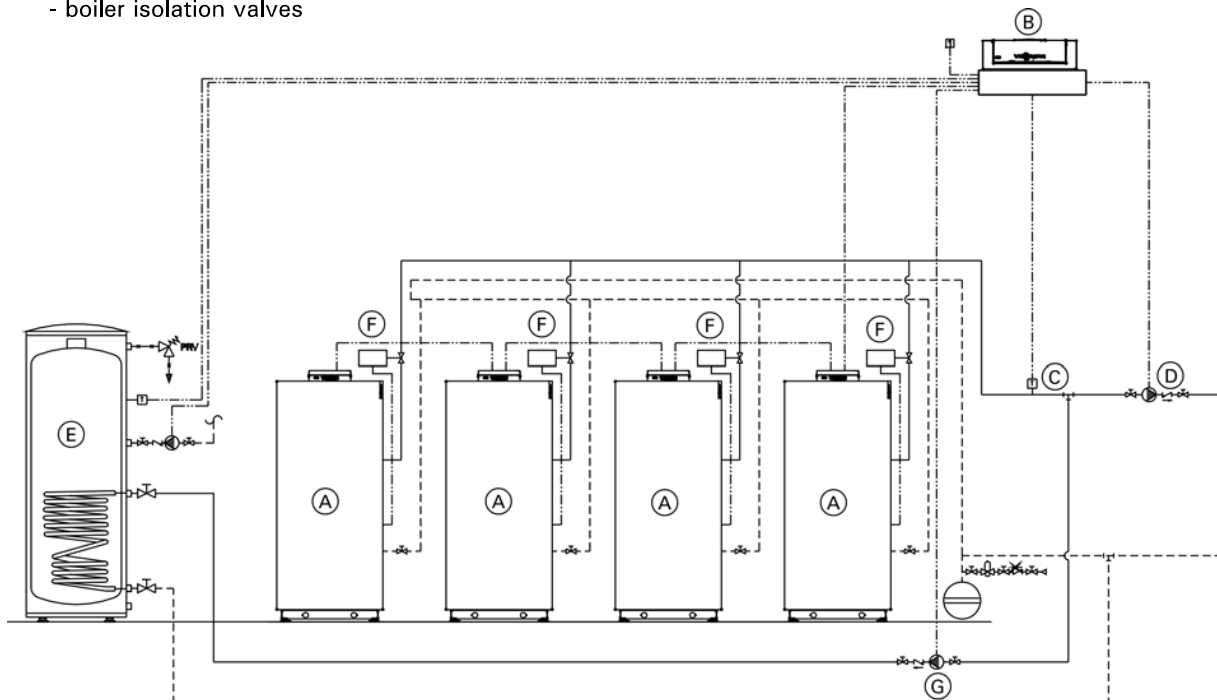

### Legend

- (A) Vitocrossal 300 CU3A boiler
- (B) Vitotronic 300K, MW2C
- (C) Common supply temperature sensor
- (D) System pump
- (E) DHW storage tank
- (F) Boiler isolation valve (power open spring return)
- (G) DHW pump

When designing a multiple Vitocrossal 300 CU3A system as shown above, please reference applicable multiple Vitocrossal 300 CU3A technical documentation, and contact your local Viessmann Sales Representative for further assistance.

This installation example depicts a possible piping layout for multiple Vitocrossal 300 CU3A boilers equipped with Viessmann System Technology. Please note that this example is based on a simplified conceptual drawing only! Piping and necessary componentry must be field verified. A low water cut-off (LWCO) must be installed where required by local codes.

Proper installation and functionality in the field is the responsibility of the heating contractor.

### WARNING

If a DHW storage tank other than a Viessmann Vitocell 100 or 300 tank is used, the installer must verify proper operation of the Viessmann DHW tank temperature sensor with the original manufacturer of the tank. Viessmann strongly recommends the installation of a temperature tempering valve in the DHW supply line.

# Electrical Connections

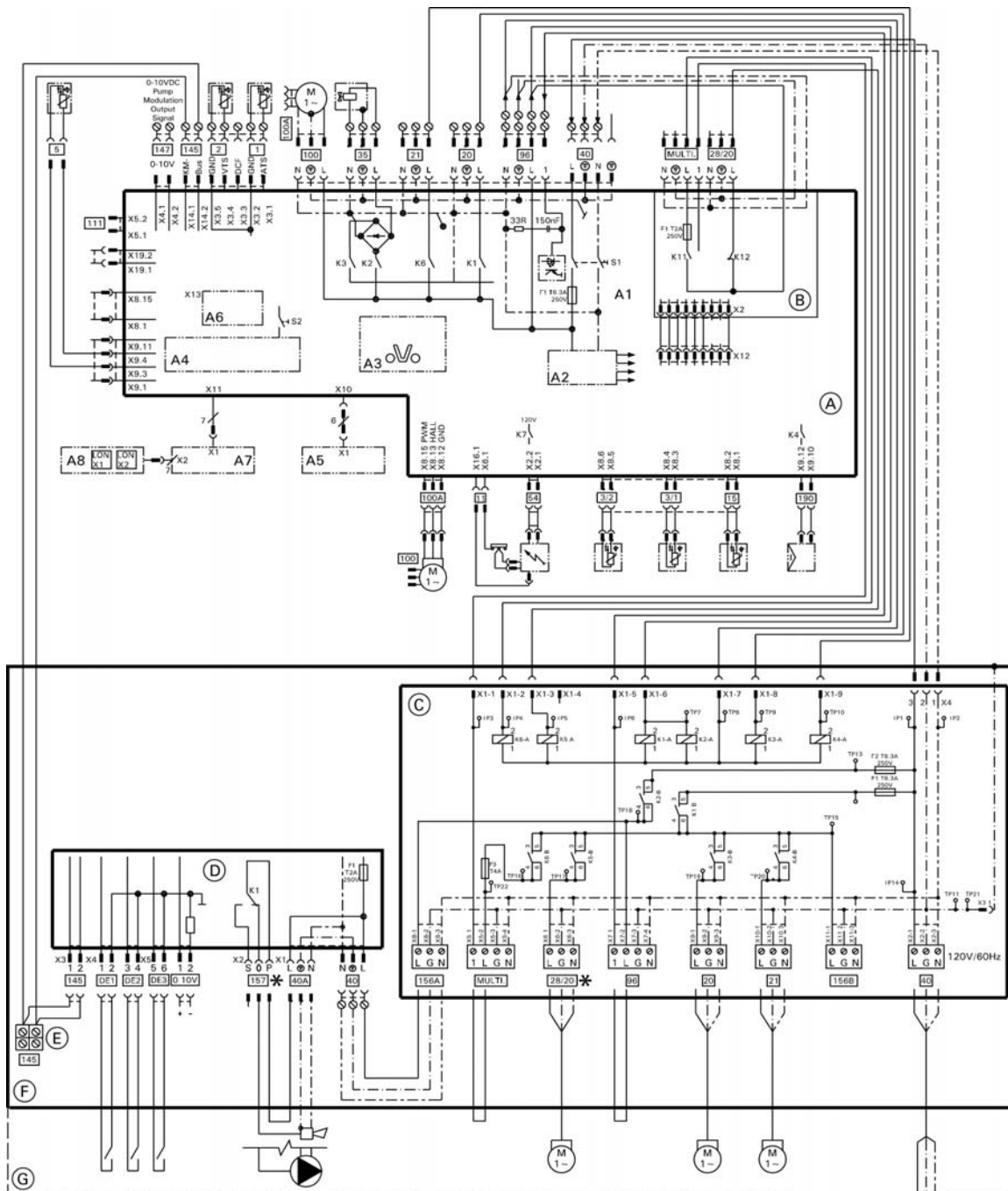

**⚠ WARNING**  
**DISCONNECT POWER BEFORE SERVICING BOILER.**

If any of the original wires as supplied with the appliance must be replaced, it must be replaced with the exact equivalent.

**⚠ CAUTION**  
 Label all wires prior to disconnection when servicing controls. Wiring errors can cause improper and dangerous operation. Verify proper operation after servicing.

\* Only one function/connection may be assigned to each connection.

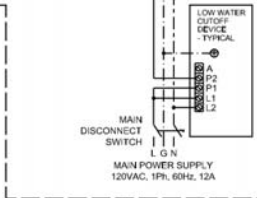

**Electrical Connections** *(continued)***Legend**

1	Outdoor Temperature Sensor
2	Supply Temperature Sensor/Low Loss Header
3/1	Boiler Temperature Sensor #1
3/2	Boiler Temperature Sensor #2
5	DHW Temperature Sensor
11	Ionization Electrode
15	Flue Gas temperature Sensor
20	Boiler Pump
21	DHW Pump
28/20	Programmable Pump Output*
35	Gas Valve
40	Power Supply
40A	Accessory Power Output
54	Ignition Transformer
96	Powered Accessory Connection
100	Fan Motor
100A	Fan Motor Control
111	Not Used
145	KM BUS
147	Pump Modulation Output 0-10VDC
Multi	Powered Accessory Connection
156A	Switched Output F2
156B	Switched Output F1
DE1	Digital Input 1 (Dry Contact)
DE2	Digital Input 2 (Dry Contact)
DE3	Digital Input 3 (Dry Contact)
0-10V	0-10VDC Input
157	Fault Alarm/DHW Recirculation Pump*
190	Gas Modulation Coil

\* See wiring diagram

- Ⓐ Boiler Control
- Ⓑ External Accessory Connection Board
- Ⓒ Power/Pump Connection Interface
- Ⓓ Integrate EA1 Module
- Ⓔ KM-BUS for External Devices
- Ⓕ Electrical Junction Box
- Ⓖ Field Wiring Connections
- A1 Main Board
- A2 Internal Power Supply Unit
- A3 Optolink
- A4 Burner Control Unit
- A5 Programming Unit
- A6 Coding Card
- A7 Connection Adaptor
- A8 LON Communication Module
- S1 ON/OFF Switch
- S2 Reset Button
- X.. Electrical Interface

## System Design Considerations

### IN THE COMMONWEALTH OF MASSACHUSETTS...

- this product shall be installed by a licensed plumber or gas fitter.
- the flexible connector (if used) cannot exceed 36".
- any level type shutoff used must be of tee handle type.

### Boiler location

As a direct vent appliance, the Vitocrossal 300 CU3A can be installed for room air independent operation (sealed combustion) regardless of size and ventilation method of the room in which it is located.

The Vitocrossal 300 CU3A can be installed, for example, in the main living area of a house, in non-ventilated utility rooms, cupboards, closets and alcoves with no clearance required from combustible materials, as well as in attics with a direct outlet for the flue gas/fresh air system. Follow all local and national codes.

### Flue gas system

Viessmann PP(s) (Polypropylene) concentric flue gas/fresh air systems for room air independent operation (sealed combustion) and side wall venting are tested to ANSI Z21.13 - CSA 4.9 (latest edition) and are certified together with the Vitocrossal 300 CU3A boiler as a constructional unit.

The Vitocrossal 300 CU3A boiler may also be vented, using an AL29-4C® special stainless steel, single-wall, room air dependent or independent venting system (UL listed for category IV), polypropylene PP(s) or CPVC single wall room air dependent or independent venting system (listed to ULCS636 or UL1738) for CAT IV appliances.

For a more detailed description of the direct vent and single-wall vent system, please refer to the Vitocrossal 300 CU3A Venting System Installation Instructions.

### Flue gas temperature protection

Flue pipes used for the Vitocrossal 300 CU3A are suitable for max. flue gas temperatures of up to 230°F (110°C).

No flue gas temperature protection is required as the maximum permissible flue gas temperature is not exceeded in any operating condition or in the event of malfunctioning.

### Low water cut-off

A low water cut-off may be required by local codes. If the boiler is installed above the radiation level, a low water cut-off device of approved type must be installed in all instances. An approved type low water cut-off device must be provided by the heating contractor. Do not install an isolation valve between the boiler and the low water cut-off.

### Water connections

Vitocrossal 300 CU3A boilers can be used in any fully pumped hot water heating system.

Minimum system pressure is 14 psig.

Chemical corrosion protection products

Corrosion does not typically occur in sealed heating systems which have been correctly installed and are correctly operated.

Many manufacturers of plastic pipes recommend the use of chemical additives. In this case, only those commercially available corrosion protection products approved for boilers with domestic hot water heating via single-wall heat exchangers (instantaneous plate heat exchangers or DHW tanks) must be used.

### Water quality

Treatment for boiler feed water should be considered in areas of known problems, such as where a high mineral content and hardness exist. In areas where freezing might occur, an antifreeze may be added to the system water to protect the system. Please adhere to the specifications given by the antifreeze manufacturer. Do not use automotive silicate based antifreeze.

Please observe that an antifreeze/water mixture may require a backflow preventer within the automatic water feed and influence components such as diaphragm expansion tanks, radiation, etc. Maximum antifreeze content is 50% for the Vitocrossal 300 CU3A boiler. Do not use antifreeze other than specifically made for hot water heating systems. System also may contain components which might be negatively affected by antifreeze.

Check total system frequently when filled with antifreeze. Advise system operator/ultimate owner that system is filled with a glycol mix. The heating contractor must provide a MSDS (Material Safety Data Sheet) for the antifreeze used to the system operator/ultimate owner.

### Total permissible hardness of the fill and top-up water

Total heating output MBH	Specific heating volume					
	< 5 USG per 3412 BTU		≥ 5 USG per 3412 BTU to < 13 USG per 3412 BTU		≥ 13 USG per 3412 BTU	
≤ 170	300 ppm	17.5 gpg	200 ppm	11.7 gpg	2 ppm	0.11 gpg
> 170 to ≤ 682	200 ppm	11.7 gpg	150 ppm	8.8 gpg	2 ppm	0.11 gpg
> 682 to ≤ 170	150 ppm	8.8 gpg	2 ppm	0.11 gpg	2 ppm	0.11 gpg
> 2050	2 ppm	0.11 gpg	2 ppm	0.11 gpg	2 ppm	0.11 gpg

ppm - parts per million  
gpg - grains per gallon

## System Design Considerations *(continued)*

### System layout

- The max. boiler water temperature for space heating and DHW production is 194°F (90°C). To minimize distribution losses, Viessmann recommends that the heating and domestic hot water systems be based on a maximum boiler supply temperature of 194°F (90°C).
- Due to the low return temperatures required for gas condensing, no mixing valves should be used in the heating circuit whenever possible. If mixing valves are required, e.g. for multi-circuit systems or underfloor heating systems, only 3-way mixing valves must be used.  
Do not use 4-way mixing valves with condensing boilers.

### Underfloor heating systems

For underfloor heating systems Viessmann recommends the use of plastic tubing with an oxygen diffusion barrier in order to prevent the diffusion of oxygen through tubing. If plastic tubing without an oxygen diffusion barrier is used in underfloor heating systems, Viessmann recommends that such systems be separated from the boiler with a heat exchanger.

Underfloor heating systems and heating circuits containing a very large volume of water must be connected to the boiler via a 3-way mixing valve; please refer to the applicable installation example in this manual.

### Oxygen diffusion barrier underfloor tubing

The boiler warranty does not cover leaks resulting from corrosion caused by the use of underfloor plastic tubing without an oxygen diffusion barrier. Such systems must have the non-oxygen diffusion barrier tubing separated from the boiler with a heat exchanger. Viessmann recommends the use of underfloor plastic tubing with an oxygen diffusion barrier.

### Warranty

Our warranty does not cover damages resulting from the following:

- installation or service by unqualified and unlicensed personnel.
- attempting to perform any repair work on the boiler other than that mentioned in the boiler literature.
- tampering with or attempting, without Viessmann permission, to readjust the factory settings of the;
  - combination gas valve
  - combustion air opening of the burner blower
- leaks resulting from corrosion caused by the use of underfloor plastic tubing without an oxygen diffusion barrier. For detailed warranty information, please read warranty sheet supplied with product.



**Quick Reference**

°C	°F
-40	-40
-35	-31
-25	-13
-20	-4
-18	0
-16	+3
-14	+7
-12	+10
-10	+14
-9	+16
-8	+18
-7	+19
-6	+21
-5	+23
-4	+25
-3	+27
-2	+28
-1	+30
0	+32
+1	+34
+2	+36
+3	+37
+4	+39
+5	+41
+6	+43
+7	+45
+8	+46
+9	+48
+10	+50
+12	+54
+14	+57
+16	+61
+18	+64
+20	+68
+25	+77
+30	+86
+35	+95
+40	+104
+50	+122
+60	+140
+70	+158
+80	+176
+90	+194
+100	+212
+110	+230

Viessmann Manufacturing Company Inc.  
 750 McMurray Road  
 Waterloo, Ontario • N2V 2G5 • Canada  
**TechInfo Line 1-888-484-8643**  
 1-800-387-7373 • Fax (519) 885-0887  
 www.viessmann.ca • info@viessmann.ca

Viessmann Manufacturing Company (U.S.) Inc.  
 45 Access Road  
 Warwick, Rhode Island • 02886 • USA  
**TechInfo Line 1-888-484-8643**  
 1-800-288-0667 • Fax (401) 732-0590  
 www.viessmann-us.com • info@viessmann-us.com

Printed on environmentally friendly  
 (recycled and recyclable) paper.



Technical information subject to change without notice.