

Project Name:  
 Engineer Name:  
 Unit Designation:  
 Submitted To:  
 Date:  
 Location :  
 Purchaser :  
 Schedule N° :



**General Features**

- Optional 24V Adaptor
- Drain Pan Heater
- Compressor Crank Case Heater
- Smart Defrost
- Compatible with (baseboard integration Qc company)
- Blue Fin
- Quiet Mode
- Turbo mode
- I Feel
- WiFi (model No)
- 8c Heating Mode
- 3D air throw
- Intelligent Pre Heating
- Auto Clean Mode
- Timer
- Memory Function
- Optional Service Tool (model N°)

**Unit Performance**

Rated Cooling Capacity (Btu/h)	9100
Cooling Capacity (Min - Max - Rated) (Btu/h)	(1535 - 10748 - 9100)
Heating Capacity (Min - Max - Rated) (Btu/h)	(3412 - 14672 - 10500)
Cooling / Heating Power Input (W)	619 / 788
Cooling / Heating Current (A)	3.00 / 3.95
EER2 (Btu/h)	14.70
COP (W/W)	3.90
SEER2	25.5
HSPF2	10.2
Dehumidifying Volume (Pint/h)	1.69

**Electrical Specification**

Power Supply	208-230V/60Hz/1
Power Supply Mode	Outdoor
Communication Cable	AWG14/4
Max. Over Current Protection (MOP) (A)	15
Min. Current (MCA) (A)	10

**Indoor unit specifications**

Indoor Unit TOSOT Model	TW09HXP2A1DI
Fan Type	Cross-flow
Air Flow Volume (CFM)	353/324/294/265/235/177/159
Set Temperature Range °C/°F	16~30/ 61~86
Sound Pressure Level (db (A))	40/37/35/32/29/26/25
Dimension (W×H×D) (inch)	32-31/64 × 11-17/32 × 7-23/32
Net Weight (kg/lb)	9.5 / 21

**Outdoor unit specifications**

Outdoor Unit Model	TW09HXP2A1DO
Compressor Type	Rotary
Compressor RLA (A)	6.5
Fan Type	Axial-flow
Outdoor Unit Air Flow Volume (CFM)	1295
Cooling Operation Ambient Temperature Range (°C/°F)	-30 ~50 / -4 ~122
Heating Operation Ambient Temperature Range (°C/°F)	-30 ~30 / -22 ~86
Sound Pressure Level (db (A))	52
Dimension (W×H×D) (inch)	31-37/64 × 21-17/32 × 13-25/32
Net Weight (kg/lb)	32 / 71

**Refrigerant & Piping**

Refrigerant Type	R410A
Refrigerant Pre Charge (OZ)	35.3
Pre charged Length (ft)	25
Gas Additional Charge (oz/ft)	0.2
Liquid Pipe / Gas Pipe (inch)	(1/4" , 3/8")
Max Distance Height (ft)	50
Max Distance Length (ft)	65

**GLOSSARY**

- SEER - Seasonal Energy Efficiency Ratio
- EER - Energy Efficiency Ratio
- HSPF - Heating Seasonal Performance Factor
- MOP - Maximum Overcurrent Protection
- MCA - Minimum Circuit Ampacity

**Indoor – Outdoor temperature range**

Cooling operation ambient temperature range is -20°F~122°F or -4°F~122°F.  
 Heating operation ambient temperature range is -22°F~86°F.

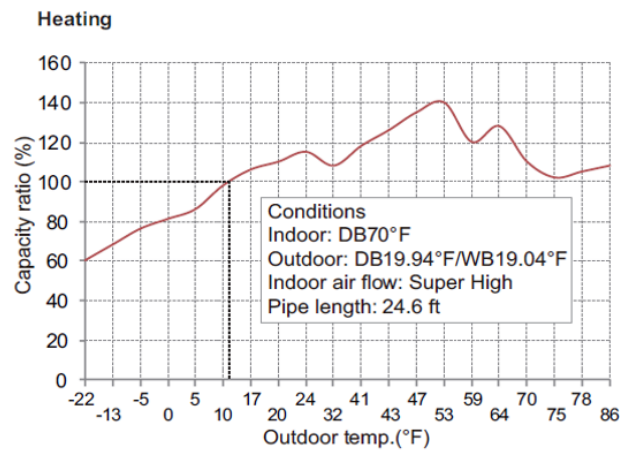
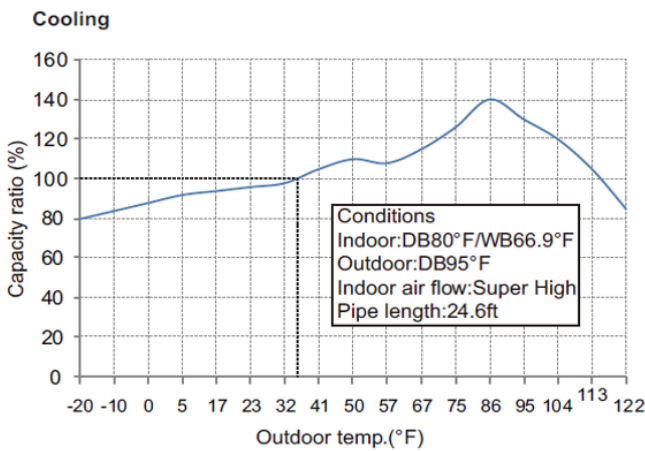

TW09HXP2A1D

Cooling

Outdoor		68F DB (20C)		Power Input	73F DB (23C)		Power Input	80F DB (27C)		Power Input	82F DB (28C)		Power Input
Coil air		57F WB (14C)			61F WB (16C)			67F WB (19C)			68F WB (20C)		
DB F	DB C	TC	SHC	TC	SHC	TC	SHC	TC	SHC	TC	SHC	TC	SHC
0	-18	4387	3181	433	4922	3568	470	5350	3879	495	5778	4189	519.7
5	-15	4601	3359	441	5136	3749	480	5564	4062	505	5992	4374	530.3
14	-10	4922	3618	468	5457	4011	509	5885	4325	535	6313	4640	562.1
23	-6	5457	4038	503	5992	4434	547	6420	4751	576	6848	5068	604.5
32	-0	5885	4384	530	6420	4783	576	6848	5102	606	7276	5421	636.3
41	5	6527	4895	574	7062	5297	624	7490	5618	657	7918	5939	689.3
50	10	7169	5413	671	7704	5817	729	8132	6140	768	8560	6463	806
59	15	7704	5855	706	8239	6262	768	8667	6587	808	9095	6912	848.4
68	20	8881	6794	794	9416	7203	864	9844	7531	909	10272	7858	954.5
77	25	9844	7580	839	10379	7992	912	10807	8321	960	11235	8651	1007
86	30	10700	8293	865	11235	8707	940	11663	9039	990	12091	9371	1039
95	35	9737	7595	883	10272	8012	960	10700	8346	1010	11128	8680	1061
104	40	8667	6804	953	9202	7224	1036	9630	7560	1091	10058	7896	1145
113	45	8025	6340	1015	8560	6762	1103	8988	7101	1162	9416	7439	1220
122	50	6955	5529	1024	7490	5955	1113	7918	6295	1172	8346	6635	1230

Heating

Outdoor		68F DB (20C)		Power Input	73F DB (23C)		Power Input	80F DB (27C)		Power Input	82F DB (28C)		Power Input
Coil air		57F WB (14C)			61F WB (16C)			67F WB (19C)			68F WB (20C)		
DB F	DB C	TC	SHC	TC	SHC	TC	SHC	TC	SHC	TC	SHC	TC	SHC
-22	-30	5840	1407	6132	1435	6424	1464	6570	1493	6570	1493	6570	1493
-13	-25	6278	1447	6570	1476	6862	1506	7008	1536	7008	1536	7008	1536
-4	-20	7008	1487	7300	1517	7592	1547	7738	1578	7738	1578	7738	1578
0	-18	9490	1514	9782	1544	10074	1575	10220	1607	10220	1607	10220	1607
6	-14	10950	1541	11242	1572	11534	1603	11680	1635	11680	1635	11680	1635
10	-12	11680	1487	11972	1517	12264	1547	12410	1578	12410	1578	12410	1578
16	-9	12994	1474	13286	1503	13578	1534	13724	1564	13724	1564	13724	1564
19	-7	13140	1407	13432	1435	13724	1464	13870	1493	13870	1493	13870	1493
24	-4	13286	1367	13578	1394	13870	1422	14016	1450	14016	1450	14016	1450
32	0	13578	1353	13870	1380	14162	1408	14308	1436	14308	1436	14308	1436
41	5	13870	1286	14162	1312	14454	1338	14600	1365	14600	1365	14600	1365
43	6	14308	1313	14600	1339	14892	1366	15038	1394	15038	1394	15038	1394
47	7	14600	1340	14892	1367	15184	1394	15330	1422	15330	1422	15330	1422
53	12	15768	1380	16060	1408	16352	1436	16498	1465	16498	1465	16498	1465
59	15	16790	1420	17082	1449	17374	1478	17520	1507	17520	1507	17520	1507
64	18	16060	1461	16352	1490	16644	1520	16790	1550	16790	1550	16790	1550
70	21	15476	1474	15768	1503	16060	1534	16206	1564	16206	1564	16206	1564
75	24	14454	1487	14746	1517	15038	1547	15184	1578	15184	1578	15184	1578

**Outline Dimension Diagram**

**INDOOR UNIT**

W	32-31/64
H	11-17/32
D	7-23/32
W1	4-1/2
W2	21-3/8
W3	6-5/8

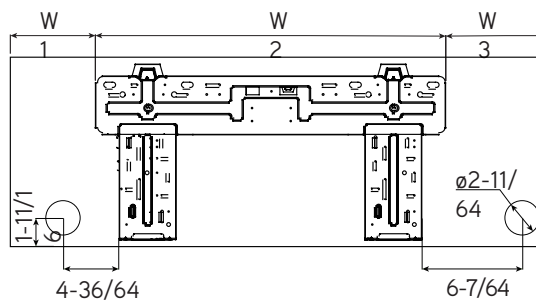
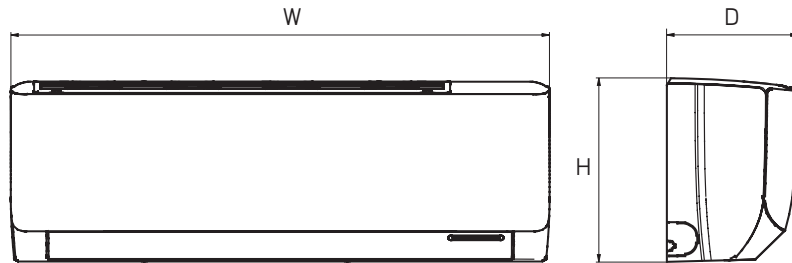

**OUTDOOR UNIT**

A	29-3/8
B	31-5/8
C	21-7/8
D	11-13/16
E	13-25/32
F	20-5/32
G	13-5/64

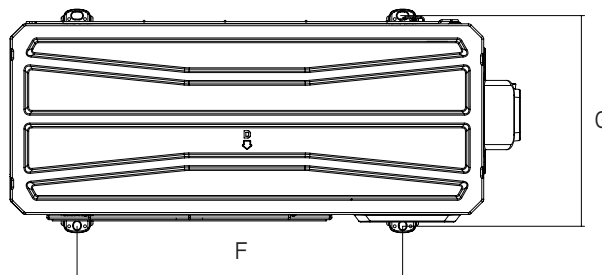
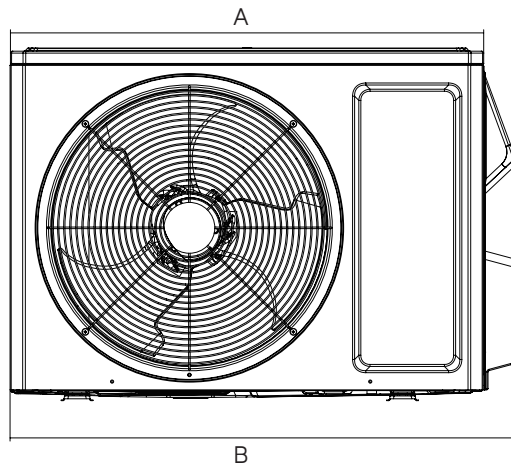

**BATHICA**  
**TOSOT**

315 Boulevard Industriel, Châteauguay,  
QC, Canada J6J 4Z2

Signature

Date

Contact: +1 (450) 698-4000  
[info@tosotamerica.com](mailto:info@tosotamerica.com)  
[tosotamerica.com](http://tosotamerica.com)