

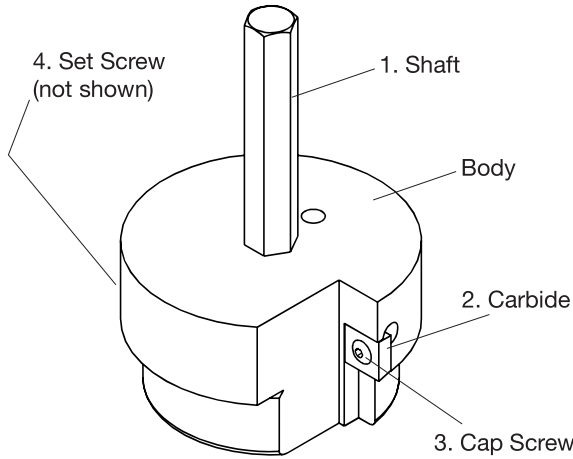

# Clean Ream Extreme®

## Operating Instructions

PPR75, PPR100, PPR125, PPR150, PPR200, PPR300, PPR400



### Parts List

Ref. No.	Description	3/4" - 1"		Qty.
		Item Code	Item Code	
1	SHAFT	44525	44524	1
2	CARBIDE INSERT	24523	24524	1
3a	8-32 CAP SCREW	—	24525	1
3b	4-40 CAP SCREW	24522	—	1
4	1/4" - 20 SET SCREW	30087	30087	1

**Rotate Carbide Insert:** Carbide insert has four cutting edges. Change cutting edge by removing the cap screw and rotating the carbide 180° then reinsert cap screw and tighten. Replace carbide as needed.

0120-54521

See Also: RP-0115-103



# Clean Ream Extreme®

## Operating Instructions

PPR75, PPR100, PPR125, PPR150, PPR200, PPR300, PPR400

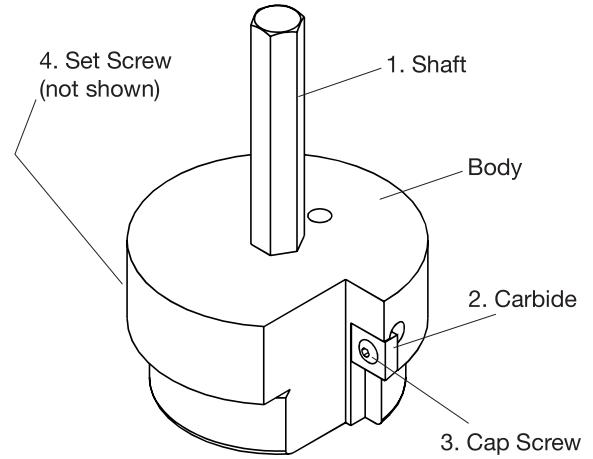

### Parts List

Ref. No.	Description	3/4" - 1"		Qty.
		Item Code	Item Code	
1	SHAFT	44525	44524	1
2	CARBIDE INSERT	24523	24524	1
3a	8-32 CAP SCREW	—	24525	1
3b	4-40 CAP SCREW	24522	—	1
4	1/4" - 20 SET SCREW	30087	30087	1

**Rotate Carbide Insert:** Carbide insert has four cutting edges. Change cutting edge by removing the cap screw and rotating the carbide 180° then reinsert cap screw and tighten. Replace carbide as needed.

0120-54521

See Also: RP-0115-103



# Clean Ream Extreme®

## Operating Instructions

PPR75, PPR100, PPR125, PPR150, PPR200, PPR300, PPR400

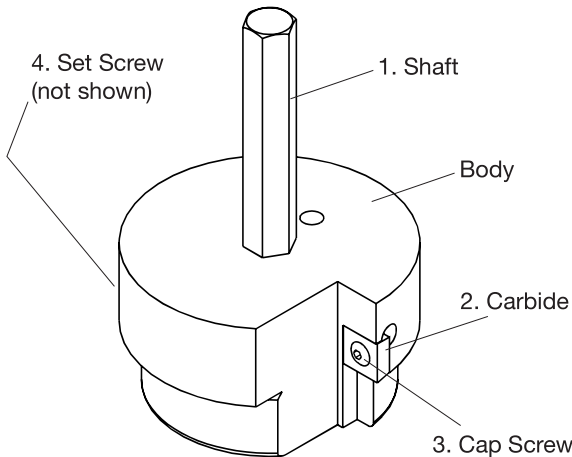

### Parts List

Ref. No.	Description	3/4" - 1"		Qty.
		Item Code	Item Code	
1	SHAFT	44525	44524	1
2	CARBIDE INSERT	24523	24524	1
3a	8-32 CAP SCREW	—	24525	1
3b	4-40 CAP SCREW	24522	—	1
4	1/4" - 20 SET SCREW	30087	30087	1

**Rotate Carbide Insert:** Carbide insert has four cutting edges. Change cutting edge by removing the cap screw and rotating the carbide 180° then reinsert cap screw and tighten. Replace carbide as needed.

0120-54521

See Also: RP-0115-103



# Clean Ream Extreme®

## Operating Instructions

PPR75, PPR100, PPR125, PPR150, PPR200, PPR300, PPR400

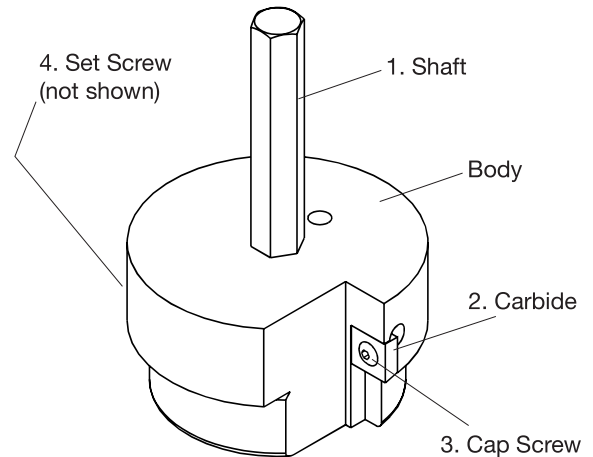

### Parts List

Ref. No.	Description	3/4" - 1"		Qty.
		Item Code	Item Code	
1	SHAFT	44525	44524	1
2	CARBIDE INSERT	24523	24524	1
3a	8-32 CAP SCREW	—	24525	1
3b	4-40 CAP SCREW	24522	—	1
4	1/4" - 20 SET SCREW	30087	30087	1

**Rotate Carbide Insert:** Carbide insert has four cutting edges. Change cutting edge by removing the cap screw and rotating the carbide 180° then reinsert cap screw and tighten. Replace carbide as needed.

0120-54521

See Also: RP-0115-103