

Series WV-DV™

Residential Oil Boilers

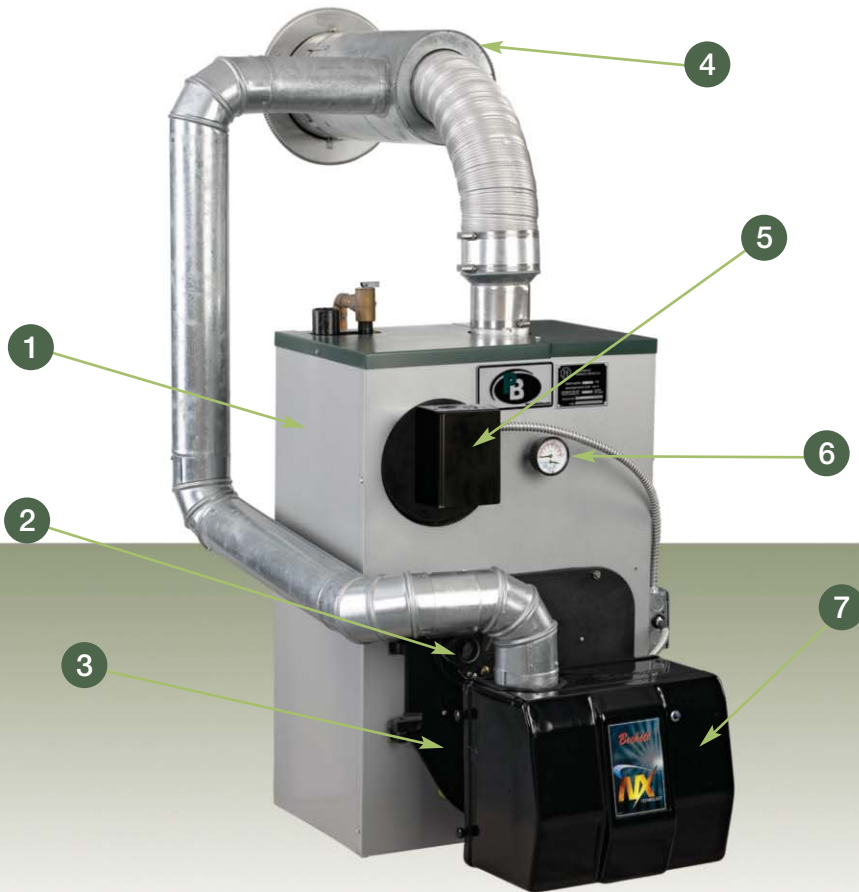

- 1 Insulated Jacket
- 2 Flame Observation Port
- 3 Full Plate Swing-Out Door
- 4 Concentric Vent Termination
- 5 Boiler Reset Control with Circulator Relay and Low Water Cut-off
- 6 Temperature-Pressure Gage
- 7 Sealed Combustion, Flame Retention, Burner

Series WV/DV™ Boiler Features

- Up to 86.7% AFUE!
- Residential, Oil-fired Boiler for Hot Water Systems
- Direct Vent, Sealed Combustion Boiler—Fully Packaged and Ready to Install
- High Efficiency, Flame Retention Burners—Choice of Beckett, Carlin or Riello
- Solid State Burner Control with Pre- and Post-Purge
- Cast Iron Sections—Factory Tested and Assembled with Steel Push Nipples
- Large Water Content, Wet Base Section Design
- Deluxe Powder Coated Steel Jacket—Reduces Boiler Heat Loss
- Full Plate Swing Out Door—For Quick and Easy Cleaning

*certain firing rates

Standard Equipment

- > Taco Circulator
- > Concentric Vent Termination Kit—Only One 8" Hole Needed Through Wall
- > Boiler Reset Control with Low Water Cut-off for Increased Efficiency and Safety
- > Drain Valve
- > Service Switch

All residential cast iron boilers include a full one-year warranty. A limited, lifetime warranty is provided for the cast iron sections of Peerless® residential hot water boilers. Visit PeerlessBoilers.com for complete details.



Technical Information

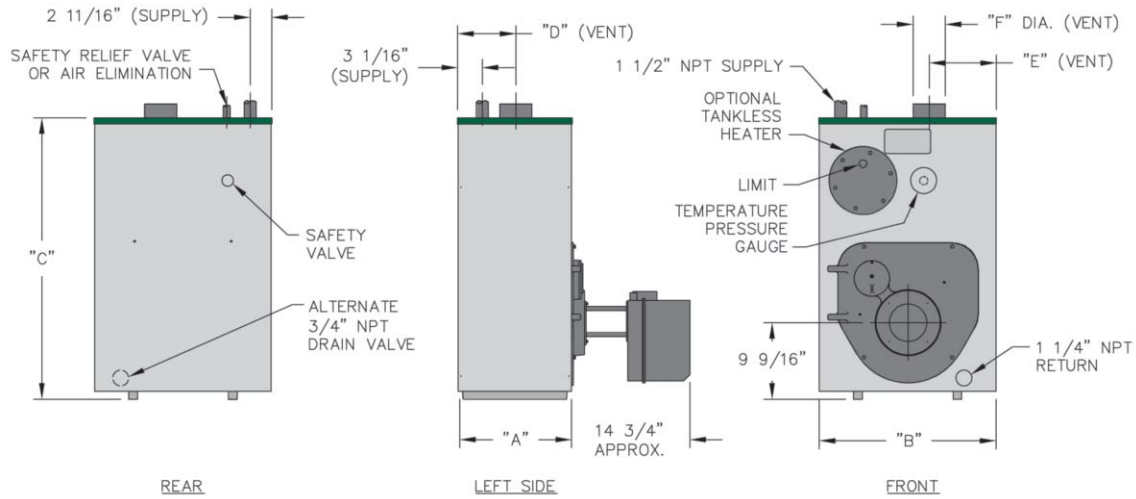

Boiler Dimensions

Boiler Model Number	Jacket Depth "A"	Jacket Width "B"	Jacket Height "C"	Rear of Jkt. to c/l of Vent "D"	Right of Jkt. to c/l of Vent "E"	Vent Size Dia. "F"
WV-DV-03	14-1/8"	22-1/8"	35"	7-1/16"	8-5/16"	4"
WV-DV-04	18-1/8"	22-1/8"	35"	9-1/16"	8-5/16"	4"

Crated Dimensions & Shipping Weights

Boiler Model Number	Length	Width	Height	Approximate Shipping Weight (lbs.)				
				Package		Vent Terminal	Venting Components Kit	
				WPC, WPCT	WPC, WPCT		WPC, WPCT	WPC
WV-DV-03	35"	28-1/2"	41-1/4"	566	575	13	10'	16
WV-DV-04	43"	28-1/2"	41-1/4"	680	698	13	15'	21
							20'	26

Boiler Ratings

Series WV-DV™						Water Content, Gallons
Boiler Model Number	Input		Heating Capacity ³ , MBH	Net Ratings Water ⁴ , MBH	AFUE ⁵ , %	
	GPH	MBH				
WV-DV-03	0.75	105	92	80	86.7	11.75
WV-DV-03	0.85	119	103	90	85.9	11.75
WV-DV-03	1.10	154	131	114	84.1	11.75
WV-DV-04	1.15	161	141	122	86.7	14.75
WV-DV-04	1.30	182	158	137	86.0	14.75

- Boiler Model No. may have the following suffix letters: WPC = Water Package w/Burner & Circulator; WPCT = Water Package w/Burner, Circulator & Tankless Coil
- Firing rate is based on a fuel oil with a heating value of 140,000 BTU per gallon. Burner input based on maximum altitude of 2,000 ft. - for other altitudes consult factory.
- Heating capacity based on D.O.E. Testing procedure with 13.0% CO₂.
- The Net Ratings shown include allowance for normal piping pick-up load.
- Heating Capacity and Annual Fuel Utilization Efficiency (AFUE) ratings are based on U.S. Government test. Before purchasing this appliance, read important information about its estimated annual energy consumption or energy efficiency rating that is available from your retailer.



PeerlessBoilers.com



Printed on Recycled Paper

PeerlessBoilers.com

CUT-WV-DV R3 (4/15-3M)
Printed in U.S.A.
©2015 PB Heat, LLC. All rights reserved.